

# ***Installation Instructions***

## **Alpha CD Easy-Flue (with Plume Management Facility)**

**CD Easy-Flue 500 mm Part No. 6.2000510**

**CD Easy-Flue 1000 mm Part No. 6.2001010**

**60/100 concentric flue for use with  
Alpha CD range of condensing boilers**

For Technical help or for Service call ...  
**ALPHA HELPLINE Tel: 0844 8718764**  
website:[www.alpha-innovation.co.uk](http://www.alpha-innovation.co.uk)

***Alpha***  
HEATING INNOVATION

Nepicar House, London Road,  
Wrotham Heath, Sevenoaks,  
Kent TN15 7RS



**EN 14471**

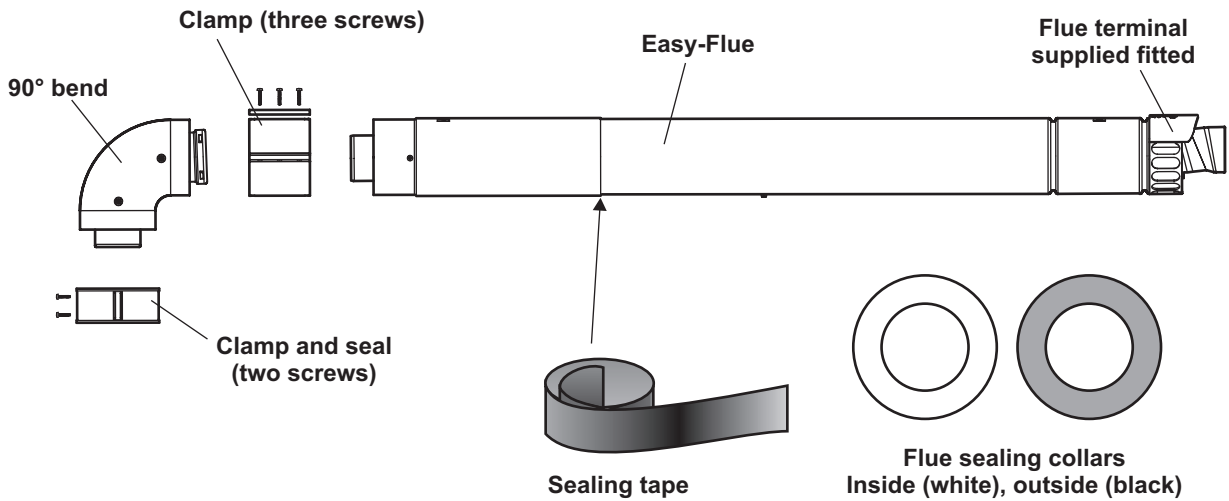

## KIT CONTENTS

### 1. GENERAL

**Note: These flues MUST ONLY be used with the Alpha Condensing boilers.**

- a. The Alpha Easy-Flue is suitable for straight horizontal flues only and can be extended up to the maximum lengths given in Section 4.
- b. The Alpha CD Easy-Flue is suitable for providing two options for management of the exhaust flue gas/plume emitted from the terminal. They are:-
  - i. Divert the plume by altering the terminal of the the Easy-Flue.
  - ii. Extend the inner flue duct by using Plume Management accessories to re-locate the terminal to an area where the plume will not cause a nuisance. **Note:** When fitting plume management accessories, ensure there is always a slope towards the Easy-Flue assembly in the wall by a minimum of 25-30 mm per metre and there is no part of the pipework where condensate/rain will collect.

Refer to Section 5 for full details.

- c. The Easy-Flue includes a 90° bend, (no separate 90° bend is required).
- d. Ensure the Easy-Flue outer duct is installed horizontally (please note that the Easy-Flue inner duct already has a pre-determined slope towards the boiler for condensate to run back towards the boiler). When extending the flue with flue extensions, these flue extensions must be installed with a slope downwards towards the boiler by a minimum of 25-30 mm per metre.
- e. The flue system must be installed in accordance with BS 5440:1.
- f. The boiler must be installed in accordance with the installation instructions supplied with the Alpha condensing boiler.
- g. The CD Easy-Flues are suitable for use in the flue length ranges shown in the tables below.

**Note:** Where the length is less than the minimum or more than the maximum, refer to Section 4.

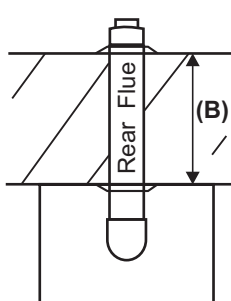

HE Boiler	B (mm)	
	Max	Min
CD Easy-Flue	500	275
500 mm	500	275
1000 mm	945	735

CD50 Boiler	B (mm)	
	Max	Min
CD Easy-Flue	430	205
500 mm	430	205
1000 mm	875	665

CD C/X/S Boiler	B (mm)	
	Max	Min
CD Easy-Flue	525	300
500 mm	525	300
1000 mm	970	760
*500 mm	*480	*255
*1000 mm	*925	*715

CDR Boiler	B Max (mm)		B Min (mm)	
	13R/18R	24R	13R/18R	24R
CD Easy-Flue	505	535	280	310
500 mm	505	535	280	310
1000 mm	950	980	740	770

\* With Premier pack

Fig. 1 - Rear Flue

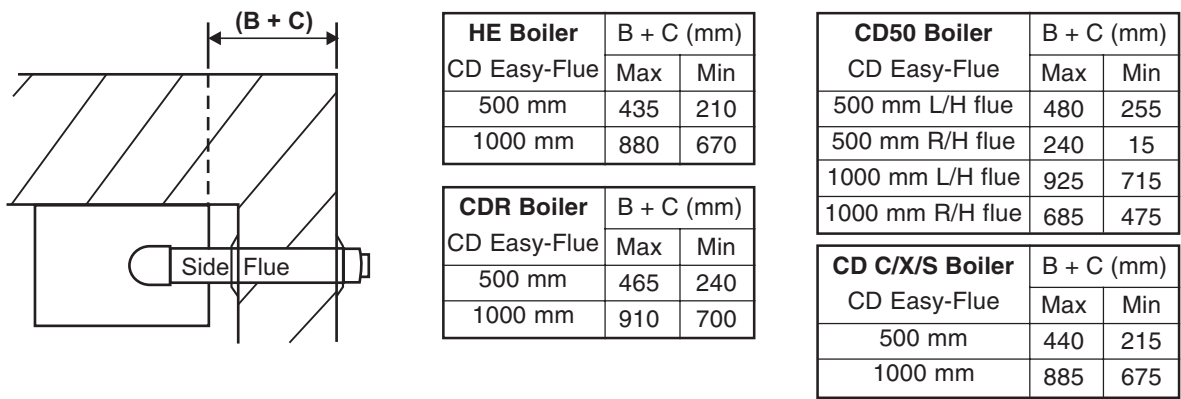

Fig. 2 - Side Flue

## 2. INSTALL THE BOILER

- Fit the boiler in accordance with the installation instructions supplied with the Alpha condensing boiler - Sections 4.1 to 4.5.
- Use the template (supplied with the boiler) to mark the flue position and cut a 110 mm diameter flue hole (or use a 107 mm core drill).

**Notes:** i. Ensure the hole is cut horizontally.

- If the Easy-Flue is being fitted internally, cut a 130 mm diameter flue hole (or use a 127 mm core drill). Refer to Section 3, paragraph (c) or Section 4.

## 3. FIT THE FLUE

The following procedure applies to fitting an Alpha CD Easy-Flue to both rear or side exit flue - horizontally only.

**Note:** If extending the Easy-Flue refer to Section 4.

- Determine the overall length (L) of flue required, (see Fig. 3) as follows:-

Rear flue  $L = \text{wall thickness (B)} + *60 \text{ mm (CD C/X/S) or } 85 \text{ mm (CD13/18R) or } 55 \text{ mm (CD24R) or } 160 \text{ mm (CD50) or } 90 \text{ mm (HE)}$

\* Add 45 mm when Premier Pack is used

Side flue  $L = \text{wall thickness (B)} + \text{distance between boiler and wall (C)} + 145 \text{ mm (CD C/X/S) or } 120 \text{ mm (CDR) or } 150 \text{ mm (HE)}$

Side flue (CD50)  $L = \text{wall thickness (B)} + \text{distance between boiler and wall (C)} + X$   
(L/H side X = 105 mm, R/H side X = 345 mm)

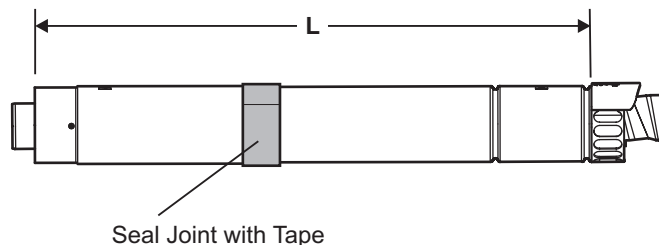

Fig. 3

- Adjust the telescopic section of the flue to the distance 'L', ensuring that the two labels marked 'TOP' are aligned, then seal and secure the joint between the ducts with the sealing tape supplied.

**Note:** Always ensure that there is a minimum overlap of 25 mm when fully extending the telescopic section.

- Pass the flue assembly through the wall (from inside or outside).

**Note: Internal fitting** - If there is no access to make good the outside wall, locate the outside (black) flue sealing collar onto the outer duct of the flue immediately before the terminal grille onto the location provided. Push the flue assembly through the 130 mm flue hole, so that the collar completely passes through the wall. Then pull the flue assembly back into the correct position. Visually check that the collar is sealing the outside wall and that it is not restricting any of the openings of the flue terminal.

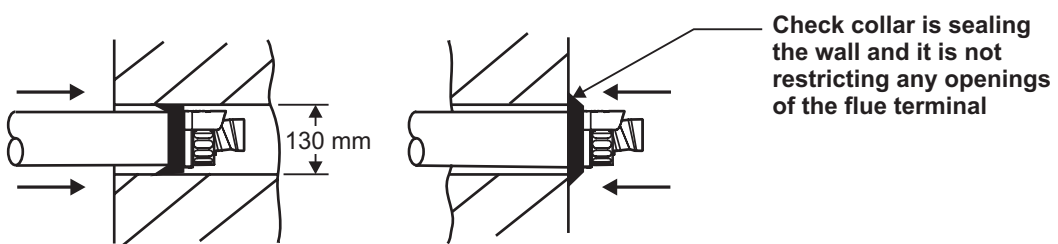
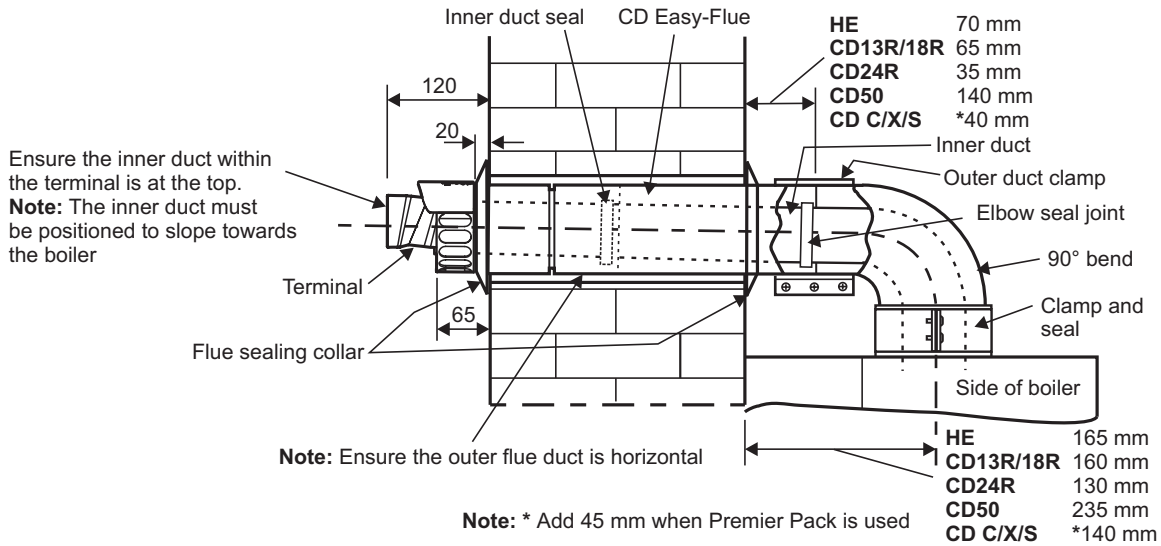

Fig. 4 - Fitting the flue from inside

- d. Position the clamp (two screws) supplied, over the bend. Fit the bend to the boiler and rotate to the correct position. Secure in position using the clamp. Ensure the clamp is located centrally over both the bend and boiler adaptor.
  - e. Fit the inside (white) flue sealing collar over the Easy-Flue. If it was not previously fitted, fit the outside (black) flue sealing collar onto the flue immediately before the terminal grille onto the location provided.
  - f. Slide the clamp (three screws) over the outer duct and pull the flue assembly towards the bend, locating the inner duct into the seal joint on the bend. Ensure the labels marked 'TOP' are positioned at the top before securing the flue assembly to the bend with the clamp (three screws) located centrally over the joint.
- Note:** Check the flue terminal protrudes 120 mm out of the wall and the inner duct of the terminal is positioned correctly (see Fig. 5).
- g. Make good the inside wall by pushing the inside flue sealing collar up to the wall.

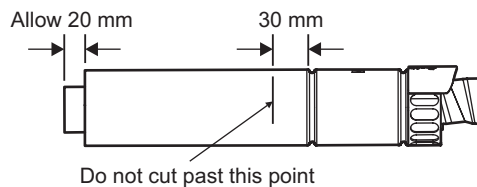

**Fig. 5 - Rear flue**

**4a. REDUCING THE FLUE - Fig. 6**

When the flue length required is less than the minimum stated in Section 1, paragraph (g), refer to Fig. 6 below. Discard the first telescopic section (**not** the section with the terminal) of the Easy-Flue 1000 mm or 500 mm and cut to the required length.

**Note:** Ensure that all cuts are square and free from burrs. Once assembled with the components pushed home, the flue is fully sealed.



**Fig. 6**

**4b. EXTENDING THE FLUE - Fig. 7**

**Note:** The flue assembly length must not exceed the maximum length stated, including the equivalent lengths of any extensions, bends etc, used for plume management components. **CD boilers must not exceed the maximum of an equivalent horizontal flue length of 12 m and HE boilers must not exceed 3 m.**

- a. When the flue length required is more than the maximum stated in Section 1, paragraph (g), refer to the table below and Figs 1 and 2.

Model	Rear Flue length (B)	Side Flue length (B + C)	Comments
CD C/S/X	Up to maximum:- * 11.885 m	Up to maximum:- 11.805 m	Alpha CD 750 mm flue extension (Part No. 6.2000750) or 1000 mm extension (Part No. 6.2001050) is required to extend the range of telescopic flue. Refer to Section 4b for instructions on how to extend the flue. <b>Note:</b> A 130 mm flue hole (127 mm core drill) may be required in the wall. This is when the extended flue is passed through the wall.
CD13R/18R	11.873 m	11.83 m	
CD24R	11.9 m	11.83 m	
CD50	11.795 m	LHS 11.845 m RHS 11.605 m	
HE	2.865 m * Subtract 45 mm if Premier Pack is used	2.8 m	

Additional support brackets are required when extending the flue. These are available from Alpha, Part no. 6.1000355.

- b. Use the template (supplied with the boiler) to mark the required flue position, ensuring there is the correct slope towards the boiler.
- c. Determine the overall flue length as described in Section 3, paragraph (a) to determine the number of Alpha CD 750 or 1000 mm flue extensions required.
- d. Assemble the flue extensions together by locating the inner duct into the seal joint and secure each extension together with the clamps supplied (three screws). Ensure that the clamps are positioned centrally over the joints.
 

**Note:** If it is required to cut an extension, **DO NOT** cut the end of the inner duct that incorporates the seal joint. Ensure the inner duct end without the seal joint is cut so that it is 20 mm longer than the outer duct. Ensure that all cuts are square and free from burrs. Once assembled with the components pushed home, the flue is fully sealed.
- e. Adjust the telescopic section of the Easy-Flue to the required length and secure the Easy-Flue with the sealing tape supplied. Fit the Easy-Flue to the extensions by locating the inner duct into the seal joint and secure with the clamp (three screws), ensuring it is located centrally over the joint.
- f. Mark the end of the flue assembly 'TOP' where it is connected to the boiler, so that the 'TOP' of the flue terminal is aligned with the 'TOP' at the boiler end of the flue assembly.
- g. Pass the complete flue assembly through the wall.
- h. Position the clamp and seal (two screws) supplied, over the bend. Fit the bend to the boiler and rotate to the correct position and secure in position. Ensure the seal is located centrally over both the bend and boiler adaptor. If the inside sealing collar (white) is being used to make good the inside wall, then it will need to be fitted before assembling the flue.
- i. Slide the clamp (three screws) over the outer duct and pull the flue assembly towards the bend, locating the inner duct into the seal joint on the bend.
- j. Secure the flue assembly to the bend with the clamp (three screws) ensuring it is positioned centrally over the joint, ensuring the 'TOP' marked on the outer duct is positioned at the top.
 

**Note:** Check the flue terminal protrudes 120 mm out of the wall and that the inner duct of the terminal is positioned correctly, i.e. the inner duct within the terminal is at the top. See Fig. 7.
- k. Make good the outside wall by fitting the outside sealing collar (black) onto the location provided immediately behind the flue terminal grille. Make good the inside wall using the inside sealing collar (white) if required.

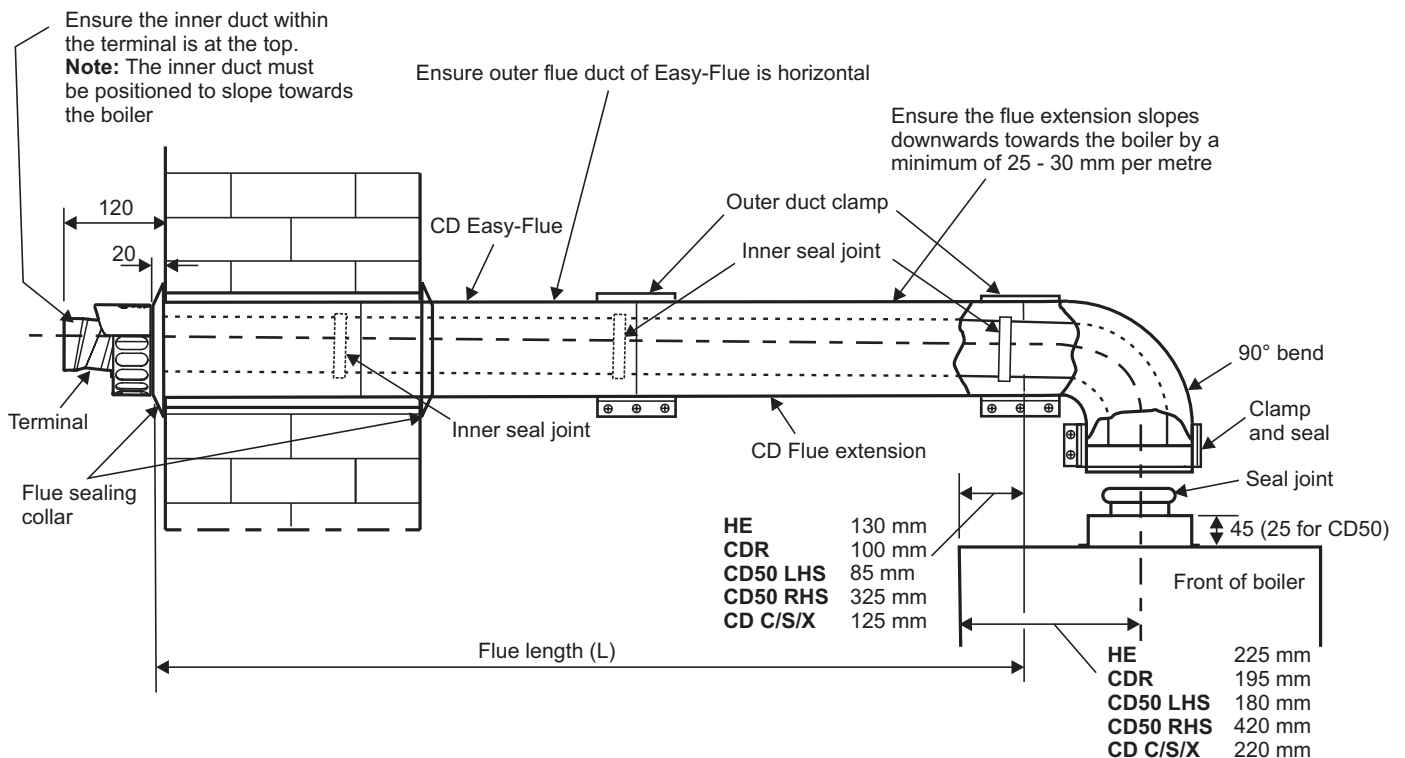

Fig. 7 - Side flue

## 5. FIT PLUME MANAGEMENT COMPONENTS - (OPTIONAL)

The following procedures detail the options for management of the exhaust flue gas/plume emitted from the terminal.

- a. The terminal supplied with the Easy-Flue can be altered to divert exhaust flue gas/plume at an angle. This can be achieved by simply turning the end section of the terminal to the desired angle.

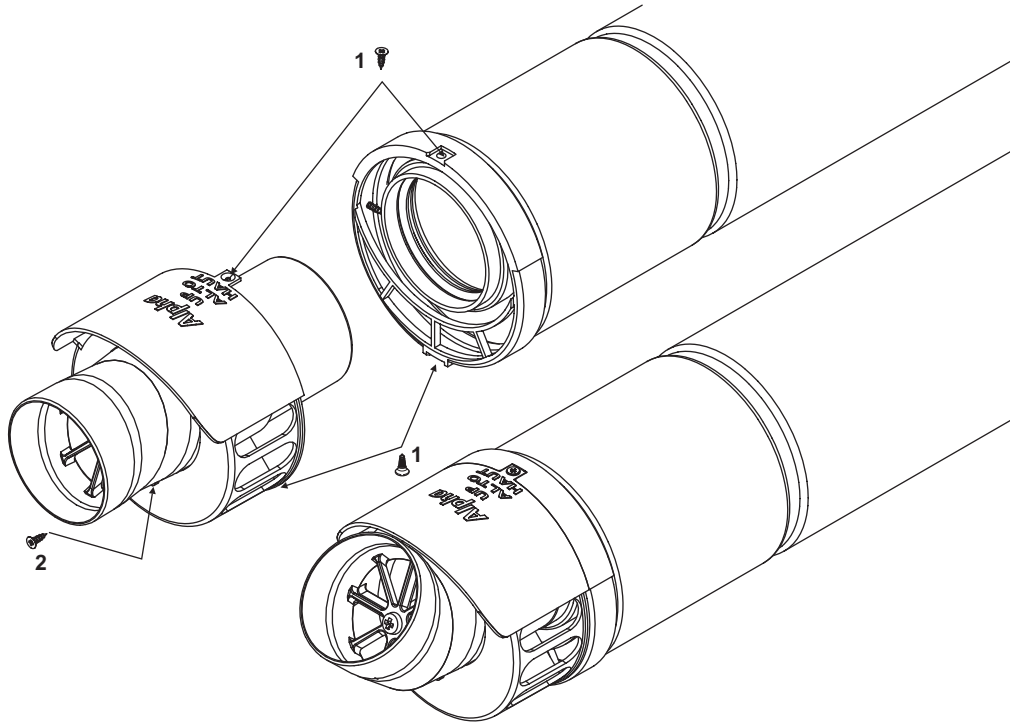
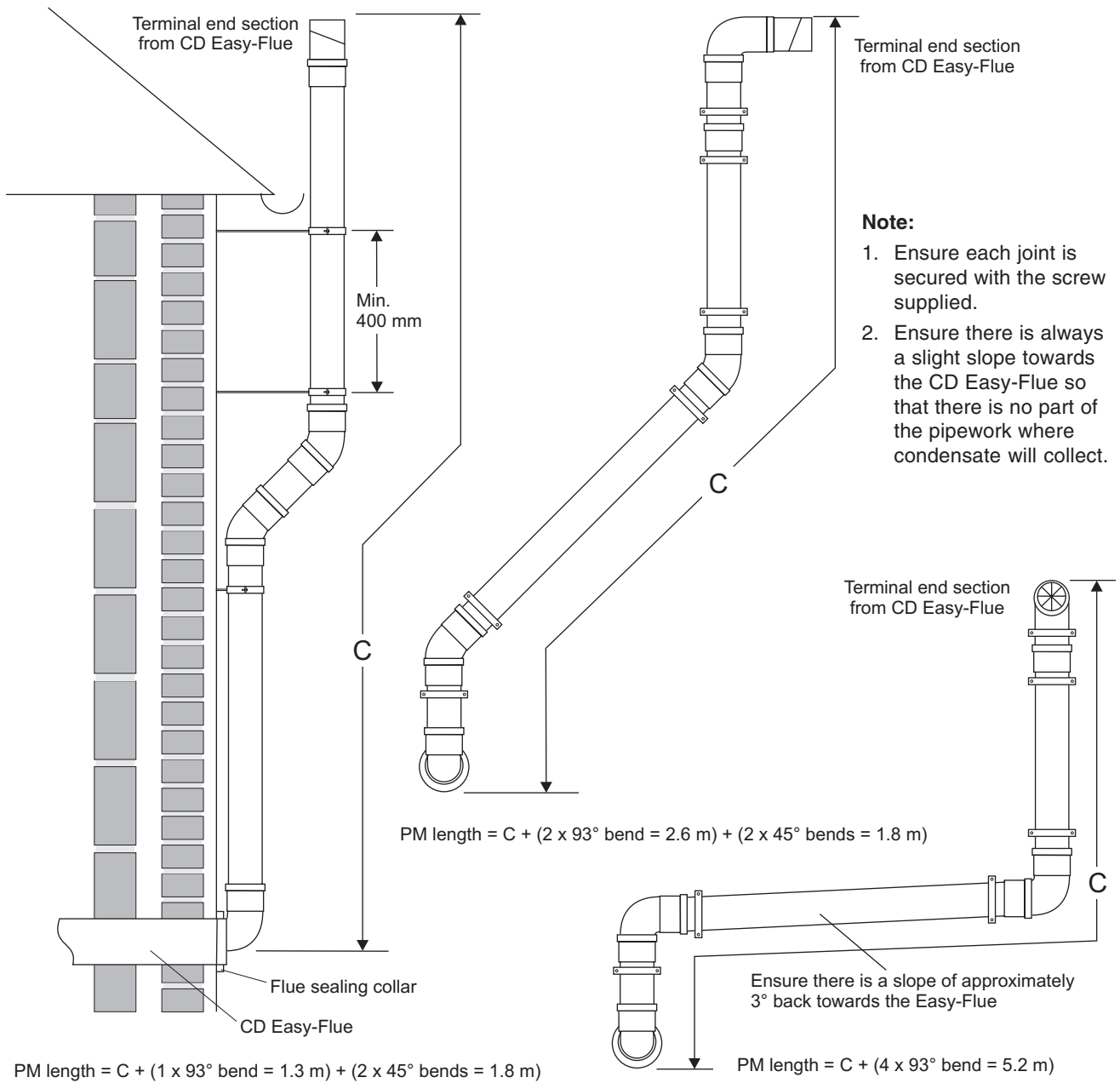

Fig. 8

- b. The CD Easy-Flue can be converted to allow the inner flue duct to be extended so as to position the terminal in an area where the exhaust flue gas/plume will not cause a nuisance. This can be done before or after installation of the flue, providing there is access to the terminal from outside.
  - i. Remove the screws (1 in Fig. 8) securing the terminal and remove the terminal by pulling it from the flue assembly. Remove the screw (2 in Fig. 8) securing the terminal end section and remove the end section from the terminal.
  - ii. Locate a 93° Plume Management bend into the flue assembly and rotate it to the direction required.
  - iii. Connect to the 93° bend the required Plume Management components as detailed and refer to Fig. 9.

**Notes:**

1. The wall support brackets must be used to secure the Plume Management pipework to the wall and prevent disconnection of the 93° bend from the flue assembly or any other component.
  2. Each joint must be secured with one of the screws provided to prevent accidental disconnection.
  3. Ensure there is always a slight slope towards the flue assembly fitted in the wall and there is no part of the plume management pipework where condensate/rain will collect and cause a blockage or any restriction.
- iv. Terminate the Plume Management pipework by fitting the terminal end section (push-fit) previously removed. Refer to Fig. 9.
  - v. The Plume Management components available for extending the inner flue duct are as follows:-
    - Plume Management 93° bend 60 mm dia. (each 93° bend equivalent to 1.3 m flue length)
    - Plume Management 45° bend 60 mm dia. (each 45° bend equivalent to 0.9 m flue length)
    - Plume Management 1000 mm extension 60 mm dia. (equivalent to 1 m flue length)
    - 60 mm dia. wall bracket



**Fig. 9**

**Note:** The equivalent horizontal flue assembly length + the equivalent plume management length (PM length) must not exceed the maximum flue length stated for each boiler, i.e.

Alpha CD boiler maximum equivalent flue length must not exceed 12 metres.

Alpha HE boiler maximum equivalent flue length must not exceed 3 metres.

# **Alpha**

HEATING INNOVATION

Alpha Therm Limited.  
Nepicar House, London Road, Wrotham Heath,  
Sevenoaks, Kent TN15 7RS  
Tel: 0844 8718764

email: [info@alpha-innovation.co.uk](mailto:info@alpha-innovation.co.uk)  
website: [www.alpha-innovation.co.uk](http://www.alpha-innovation.co.uk)

*These instructions have been carefully prepared but we reserve the right to alter the specification at any time in the interest of product improvement.  
© Alpha Therm Limited 2010.*