

Outdoor unit

WOYG112LHT

WOYG140LCTA

WOYK160LCTA

Hydraulic unit

024133

024134

INSTALLATION AND COMMISSIONING

Alféa Excellia A.I.
Air/water heat pump split 1 service



■ Installation and maintenance regulations

The appliance must be installed and maintained by an approved professional in accordance with current regulations and codes of practice.

■ Handling

The outdoor unit **must not** be placed in a horizontal position during transport.

If not kept upright during transport, the appliance could be damaged through displacement of the refrigerant and damage to the compressor suspension.

Any damage caused by transportation in a horizontal position is not covered by the warranty.

If necessary, the outdoor unit may be tilted only during manual handling (to go through a door or up a staircase). This operation must be conducted very carefully and the appliance must be immediately restored to the upright position.

■ Containment of refrigeration circuits

All refrigeration circuits are sensitive to contamination from dust and moisture. If such pollutants penetrate the refrigeration circuit, they can affect the reliability of the heat pump.

- **Make sure that the connections and refrigeration circuits (hydraulic unit, outdoor unit) are protected correctly.**
- **In the event of a subsequent failure and following an inspection, the presence of moisture or foreign bodies in the compressor oil would automatically void the warranty.**
- Check upon receipt that the fittings and refrigeration circuit caps mounted on the hydraulic unit and outdoor unit are properly seated and secured (cannot be loosened with bare hands). If this is not the case, tighten them using a C spanner.
- Check that the refrigeration connections are sealed (plastic caps or tubes crimped at the ends and brazed). If the caps must be removed during the installation (tubes to be re-cut for example), put them back as soon as possible.

■ Hydraulic connections

The connection must comply with industry standard practice according to current regulations.

Remember: Seal everything when fitting in accordance with industry standard practice for plumbing work:

- Use suitable seals (fibre gasket, O-ring).
- Use Teflon or hemp tape.
- Use sealing paste (synthetic depending on the case).

Use glycol/water mix if the minimum flow temperature is set below 10°C. If you are using a glycol/water mix, arrange for an annual check on the quality of the glycol. Use monopropylene glycol only. The recommended concentration is 30% minimum.

Never use monoethylene glycol.

- **In some installations, the presence of different metals can cause corrosion problems; the formation of metal particles and sludge can appear in the hydraulic circuit.**
- **In this case, it is advisable to use a corrosion inhibitor in the proportions indicated by the manufacturer.**
- **You must also ensure that treated water does not become corrosive.**



■ Electrical connections

• **Before any maintenance operation, ensure that the general power supply is switched off.**

• Specifications of electricity supply

The electrical installation must be carried out in accordance with prevailing rules.

Electrical connections will only be made once all other installation operations (fastening, assembly, etc.) have been completed.

Warning!

The contract signed with the energy provider must be sufficient not only to cover the heat pump's power requirements but also the combined sum of all the appliances likely to be operating at the same time. If the power is too low, check the power rating stated in your contract with your energy provider.

Never use a power socket for the power supply.

The heat pump must be supplied directly with power (without external switch) by special protected leads from the electric panel via dedicated bipolar circuit breakers, C curve for the outdoor unit, C curve for the electrical heating and domestic water backups (see tables page 35).

The electrical installation must be fitted with a 30mA RCD.

This appliance is designed to operate using a nominal voltage of 230 V or 400 V, +/- 10%, 50 Hz (depending on model).

• General remarks on electrical connections

It is essential to maintain neutral-phase polarity when making electrical connections.

Rigid wires are preferable for fixed installations, particularly in a building.

Tighten the cables using the cable glands to prevent the feed wires from being accidentally disconnected.

The earth connection and its continuity must be ensured.

• Connecting to screw terminals

• **The use of ring, spade or blade terminals or caps is prohibited.**

- Always select wire that complies with current standards.

- Bare the end of the wire to around 25 mm.

- With round end pliers, form a loop with a diameter which matches the tightening screws on the terminal.

- Tighten the terminal screw firmly onto the loop created. Insufficient tightening can cause overheating, leading to breakdown or even fire.

Rigid wire

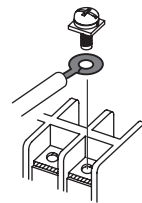
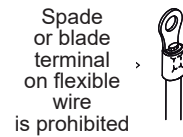
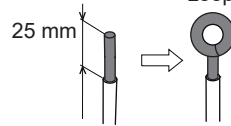

Screw and special washer

Terminal

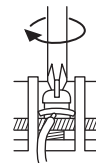

• Connecting to controller boards

- Remove the corresponding connector and make the connection.

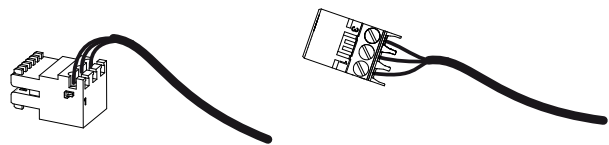

Pre-cabled bundle connector and/or screw connector

• Connecting to spring terminals

- Bare the end of the wire to around 10 mm.

- Push the spring with a screwdriver so that the wire enters the cage.

- Slide the wire into the opening provided for this purpose.

- Remove the screwdriver and then check that the wire stays gripped by the cage by pulling on it.

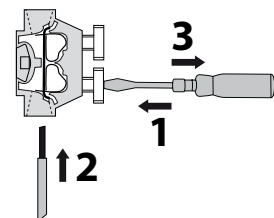
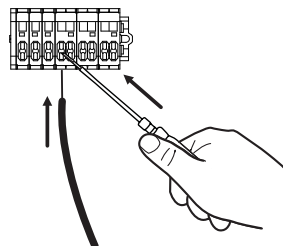









This appliance must be installed by qualified personnel holding a certificate of competence in the handling of refrigerants.

Contents

Q Description of the equipment	6
Packing	6
Unpacking and supplies	6
Definitions	6
General characteristics	7
Description	12
Operating principle	14
🏠 Installation	16
Installation of refrigeration connections	16
Installation of the outdoor unit	18
Installation of the hydraulic unit	20
↻ Refrigeration connections and filling the installation with gas	22
Rules and precautions	22
Shaping the refrigeration pipes	22
Checks and connection	25
Filling the installation with gas	26
💧 Hydraulic connections	30
Connecting the hydraulic unit to the heating circuit	30
Filling and bleeding the installation	31
Heating circulation pump speed settings	32
🔧 Electrical connections	34
Cable dimensions and protection rating	35
Electrical connections on the single phase outdoor unit side	36
Electrical connections on the 3-phase outdoor unit side	37
Electrical connections on the hydraulic unit side	38
Outside sensor	42
Room sensor (option)	42
⚙️ Commissioning	44
🖥️ Controller Interface	46
User Interface	46
Display Description	47
Installer Menu	48
Navigating the Menus	48
Modifying Settings	49
Temperature control	50

<hr/>	
 Controller Menu.	52
Menu Structure	52
Installed options	53
Hydraulic configuration	53
Heat Pump Configuration	58
System status	60
Auxiliary functions	62
Settings	64
Easy Start	68
<hr/>	
Basic Hydraulic Layout	70
<hr/>	
Electrical Cabling Plans	72
<hr/>	
 Fault Diagnosis	76
Faults in the Hydraulic Unit	76
Faults in the Outdoor Unit	77
<hr/>	
 Maintenance of the installation	78
Hydraulic checks	78
Checking the outdoor unit	78
Electrical checks.	78
<hr/>	
 Other maintenance	79
Emptying the hydraulic unit	79
Distribution valve	79
<hr/>	
 Quick-start procedure.	80
Start-up check-list	80
Commissioning technical datasheet.	82
<hr/>	
ErP performance figures.	84
Definition of ErP	84
ErP specification.	84
Package datasheet	86
<hr/>	
 Instructions for the end user	87

Q Description of the equipment

► Packing

- **1 package:** Outdoor unit.
- **1 package:** Hydraulic unit and outside temperature sensor.

► Unpacking and supplies

While the courier is still present, carefully check the general appearance of the appliances and check that the outdoor unit has not been laid in a horizontal position.

In the event of a dispute, send any relevant reservations to the carrier in writing within 48 hours and send a copy of the letter to Customer Services.

► Definitions

- **Split:** The heat pump consists of two elements (an outdoor unit to be installed outdoors and a hydraulic unit to be installed inside the dwelling).
- **Air/water:** The surrounding air is the energy source. This energy is transmitted to the heating circuit water by the heat pump.
- **Inverter:** The fan and compressor speeds are modulated according to the heating requirements. This technology enables you to save on energy and operate on a single-phase power supply, whatever the heat pump's output, by avoiding pulling significant amounts of current at start-up.
- **COP (Coefficient of Performance):** This is the relationship between the energy transmitted to the heating circuit and consumed electrical energy.

Packing contents list

Heat Pump		Outdoor unit		Hydraulic unit	
Model	Code	Reference	Code	Reference	Code
Alféa Excellia A.I. 11	526245	WOYG112LHT	700197	Alféa Excellia A.I. single phase	024133
Alféa Excellia A.I. 14	526243	WOYG140LCTA	700175	Alféa Excellia A.I. single phase	024133
Alféa Excellia A.I. tri 16	526244	WOYK160LCTA	700178	Alféa Excellia A.I. 3-phase	024134

▼ Optional equipment

- **dual circuit kit** (code 570630 (074725+075311)) for connecting 2 heating circuits.
- **6 kW backup relay kit** (code 075327) for switching to HP electrical backup of 3 to 6 kW.
- **Boiler connection kit** (code 073989) for connecting a boiler to the heat pump.
- **Wireless room sensor A59**(code 074208) for correcting the ambient temperature.
- **Wireless room sensor A75** (code 074213), **Wireless room sensor A78** (code 074214) for correcting the ambient temperature and programming the heat pump.
- **Cooling kit** (code 075312).
- **High flow rate circulation pump kit** (code 074067) for the installation of 1 underfloor heating circuit
- **Anti-vibration blocks** (code 523574).
- **White PVC floor support** (ref. 809532) or **Black rubber floor support** (ref. 809536).

▼ Operating Range

This heat pump provides:

- Heating in winter,
- The management of electrical backups, for extra heating on the coldest days,
- Management of two heating circuits*,
- Production of domestic hot water* (provided that it is combined with a mixed DHW tank),
- Cooling in summer* (for underfloor heating-cooling system or fan-convectors).

*: These options require the use of additional kits (see chapter "Required accessory" or "Optional equipment").

► General characteristics

Model name	Alféa Excellia A.I.	11	14	tri 16
Rated heating performances (outdoor temp. / flow temp.)				
Heat output				
+7°C/+35°C - Underfloor heating system	kW	10.80	13.50	15.17
-7°C/+35°C - Underfloor heating system	kW	10.38	11.54	12.98
+7°C/+55°C - Radiator	kW	7.59	9.48	12.24
-7°C/+55°C - Radiator	kW	7.57	9.20	12.00
Power consumption				
+7°C/+35°C - Underfloor heating system	kW	2.54	3.23	3.70
-7°C/+35°C - Underfloor heating system	kW	4.32	5.08	5.40
+7°C/+55°C - Radiator	kW	3.07	3.95	4.93
-7°C/+55°C - Radiator	kW	4.57	5.08	6.89
Coefficient of performance (COP)	(+7°C/+ 35°C)	4.25	4.18	4.10
Electrical specifications				
Electrical voltage (50 HZ)	V	230	230	400
Maximum current for appliance	A	22	25	10.5
Nominal current	A	11.4	14.2	5.5
Maximum current of the Heating system electrical backup	A	13.05 / 26.1	13.05 / 26.1	3x13
Power of the Heating system electrical backup	kW	6 kW (single phase)	6 kW (single phase)	9 kW (3-phase)
Fan actual power consumption	W	2x100	2x100	2x104
Circulation pump actual power consumption	W	39.5	39.5	39.5
Maximum power consumed by the outdoor unit	W	5060	5750	7245
Rate according to EN14825		0.0049	0.0039	0.0045
Hydraulic Circuit				
Maximum operating pressure	MPa (bar)	0.3 (3)	0.3 (3)	0.3 (3)
Flow rate of the hydraulic circuit for 4°C<Δt<8°C (rated conditions) minimum / maximum	l/h	1170 / 2340	1460 / 2920	1650 / 3290
Miscellaneous				
Weight of outdoor unit	Kg	92	92	99
Noise level at 1 m ¹ (hydraulic unit)	dB (A)	39	39	39
Sound power level in accordance with EN 12102 ² (hydraulic unit)	dB (A)	46	46	46
Noise level at 5 m ¹ (outdoor unit)	dB (A)	47	47	47
Sound power level in accordance with EN 12102 ² (outdoor unit)	dB (A)	69	69	69
Weight of hydraulic unit (empty / full of water)	Kg	42 / 58	42 / 58	42 / 58
Hydraulic unit water capacity	l	16	16	16
Heating system operating limits				
Outdoor temperature min/max	°C	-25 / +35	-25 / +35	-25 / +35
Max. heating water flow temperature underfloor heating	°C	45	45	45
Max. heating water flow temperature low temperature radiator	°C	60	60	60
Min. flow water temperature	°C	8	8	8
Refrigeration circuit				
Gas pipe diameters	Inches	5/8	5/8	5/8
Liquid Piping Diameters	Inches	3/8	3/8	3/8
Factory fill of refrigerant R410A ³	g	2500	2500	2500
Maximum operating pressure	MPa (bar)	4.15 (41.5)	4.15 (41.5)	4.15 (41.5)
Minimum / Maximum length of pipes ⁴	m	5 / 15	5 / 15	5 / 15
Maximum length of pipes ⁵ / Maximum level difference ⁵	m	20 / 15	20 / 15	20 / 15

¹ Sound pressure level at (x) m from the appliance, 1.5m off the ground, open field directionality 2.

² The sound power level is a laboratory measurement of the emitted sound power. It does not correspond to a measurement of the perceived sound power.

³ Refrigerant R410A as per NF EN 378.1 standard.

⁴ Filling with refrigerant R410A is done at the factory.

⁵ Taking into account a possible additional fill of refrigerant R410A (see "Additional filling", page 28).

**Outdoor Unit,
Excellia A.I. 11 and 14**

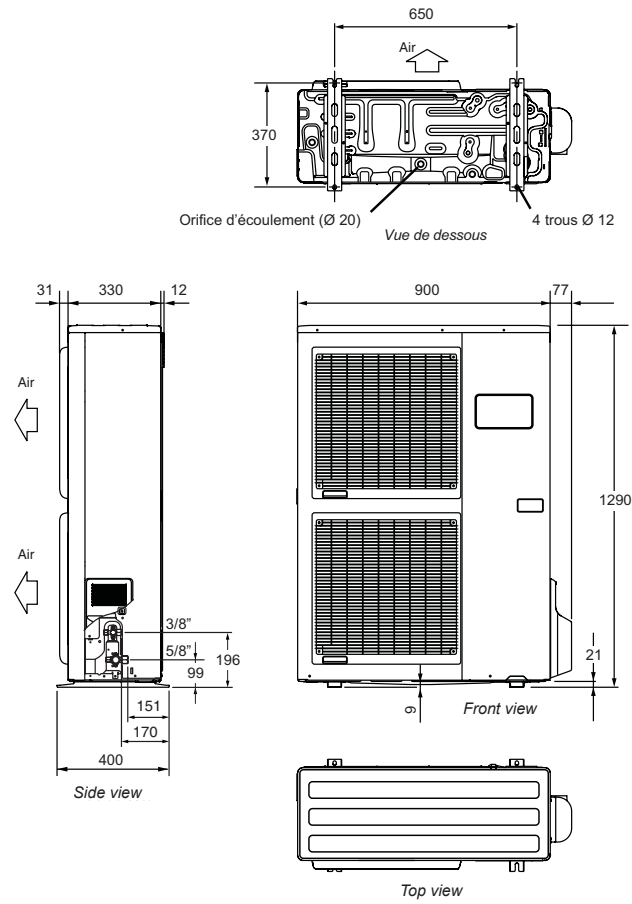

**Outdoor Unit,
Excellia A.I. tri 16**

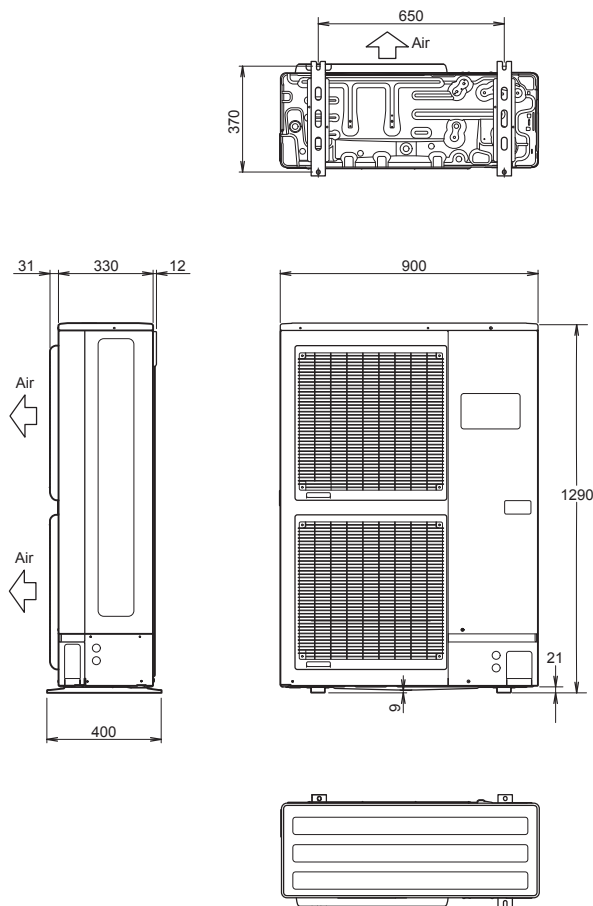

fig. 1 - Dimensions in mm

Hydraulic unit



Space requirements of the hydraulic unit, see [page 20](#).

fig. 2 - Dimensions in mm

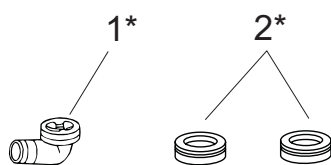

1	Elbow	for condensate evacuation.
2	Plugs (x2) (depending on model)	

fig. 3 - Accessories provided with the outdoor unit

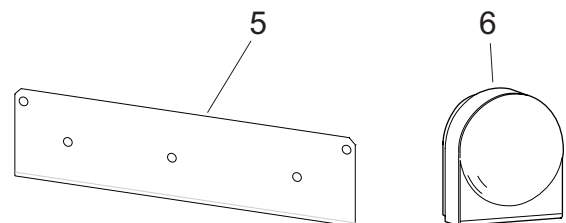

5	Bracket	for attaching hydraulic unit.
6	Outside sensor	to monitor the outdoor temp.

fig. 4 - Accessories provided with the hydraulic unit

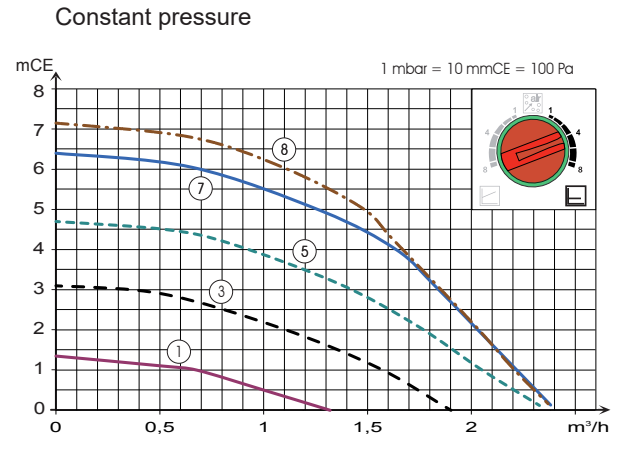
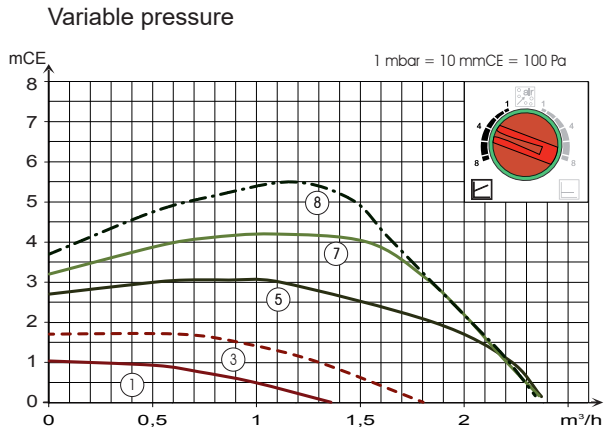

fig. 6 - Available hydraulic pressures and flow rates

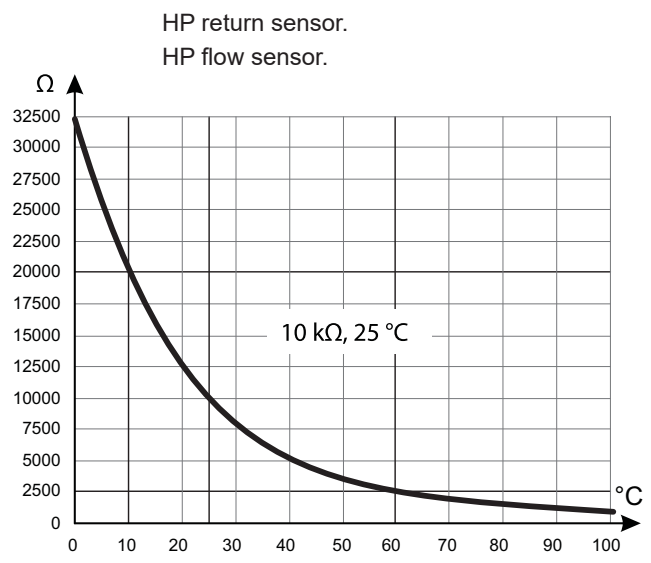
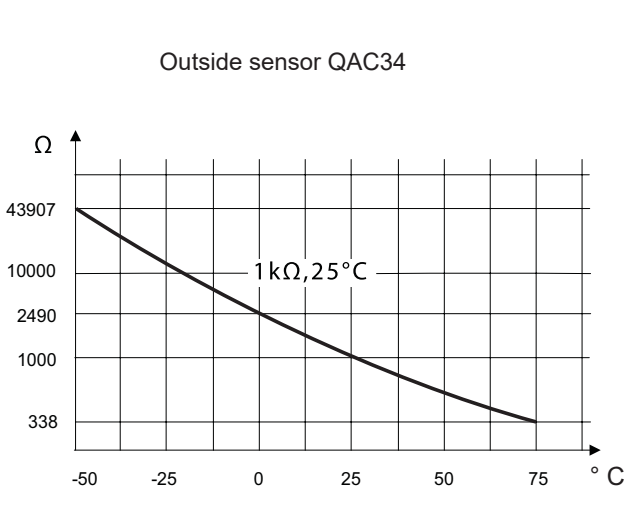

fig. 5 - Ohmic sensor values (Hydraulic unit)

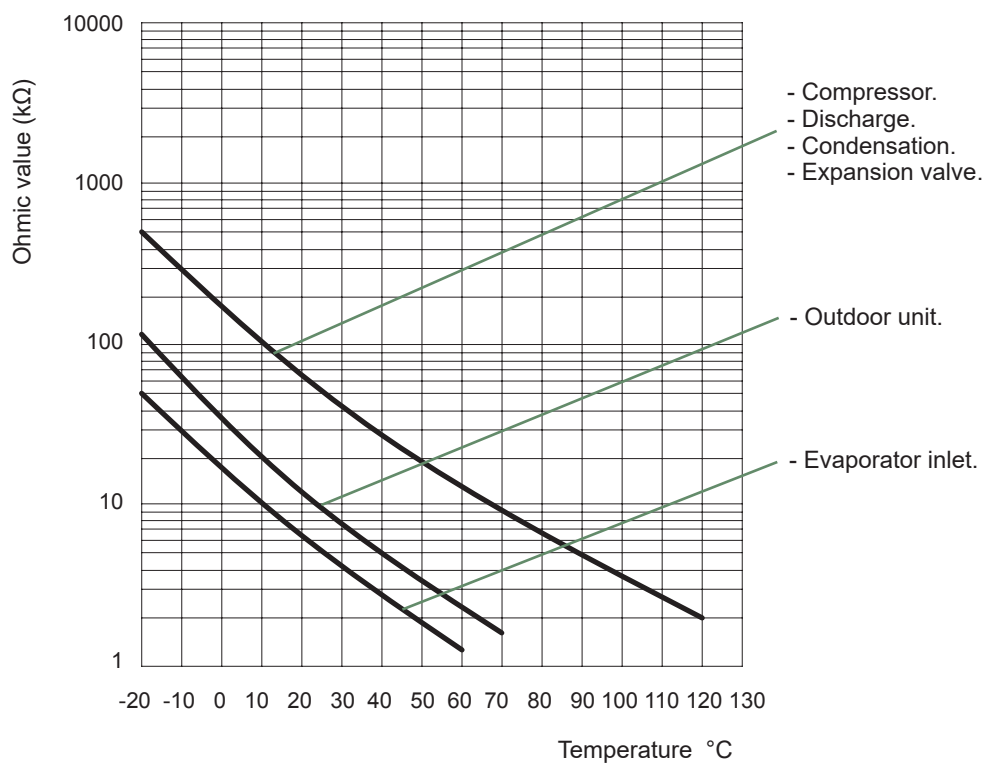
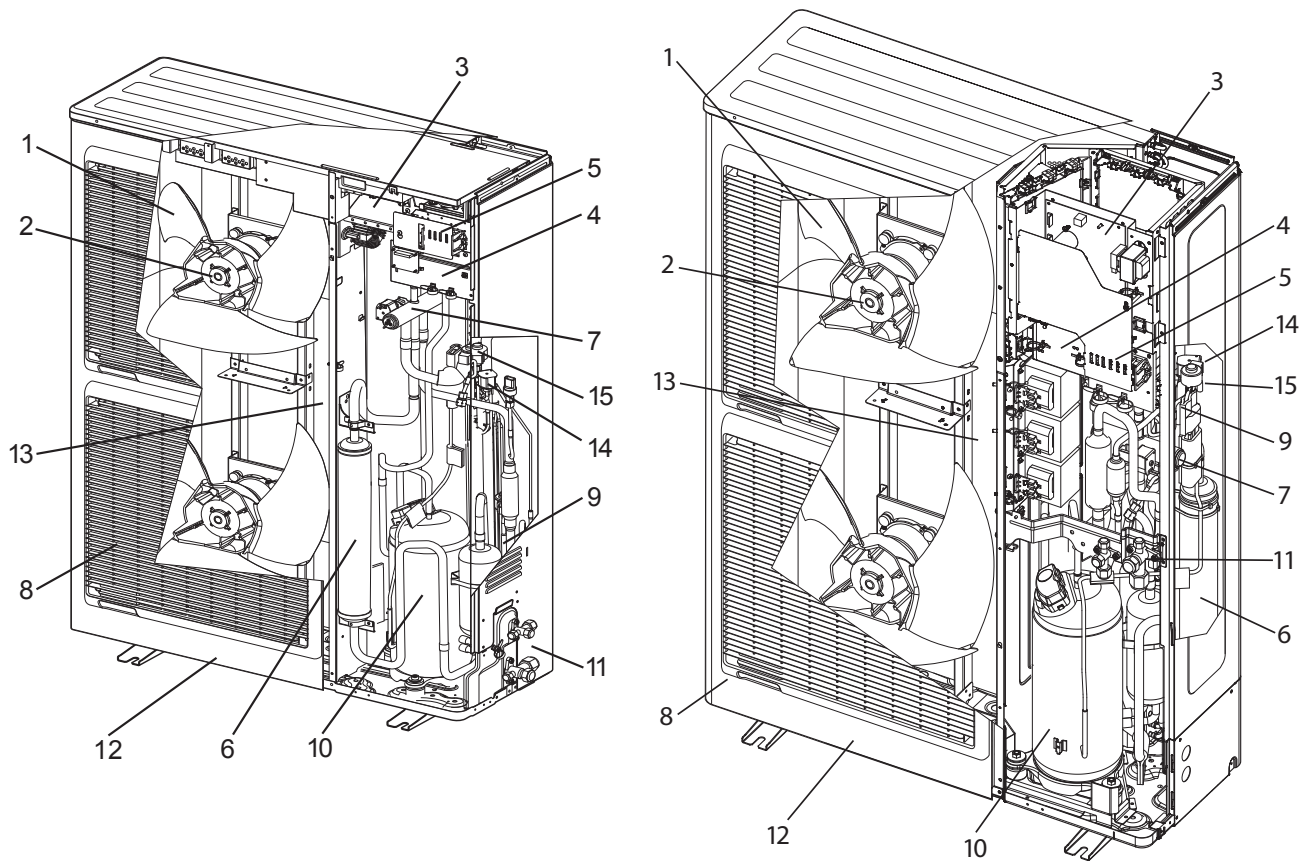

fig. 7 - Ohmic sensor values (Outdoor unit)

► Description

Alféa Excellia A.I. 11 and 14

Alféa Excellia A.I. tri 16



Key:

1. High performance and low noise impeller.
2. Electrical motor with variable "inverter" operation.
3. "Inverter" control unit.
4. Check lights and buttons.
5. Connection terminal blocks (power supply and interconnection).
6. Refrigerant storage bottle.
7. 4-way valve.
8. Anti-corrosion treated bodywork.
9. Main circuit electronic expansion valve.
10. Noise and thermally insulated "inverter" compressor with liquid injection port.
11. Refrigeration connection valves (flared connectors) with protective caps.
12. Holding tank with condensate drain hole.
13. High-performance exchange surface evaporator; anti-corrosion treated hydrophilic aluminium fins and grooved copper tubes.
14. Solenoid valve for liquid injection.
15. Electronic expansion valve for liquid injection.

fig. 8 - Outdoor unit components

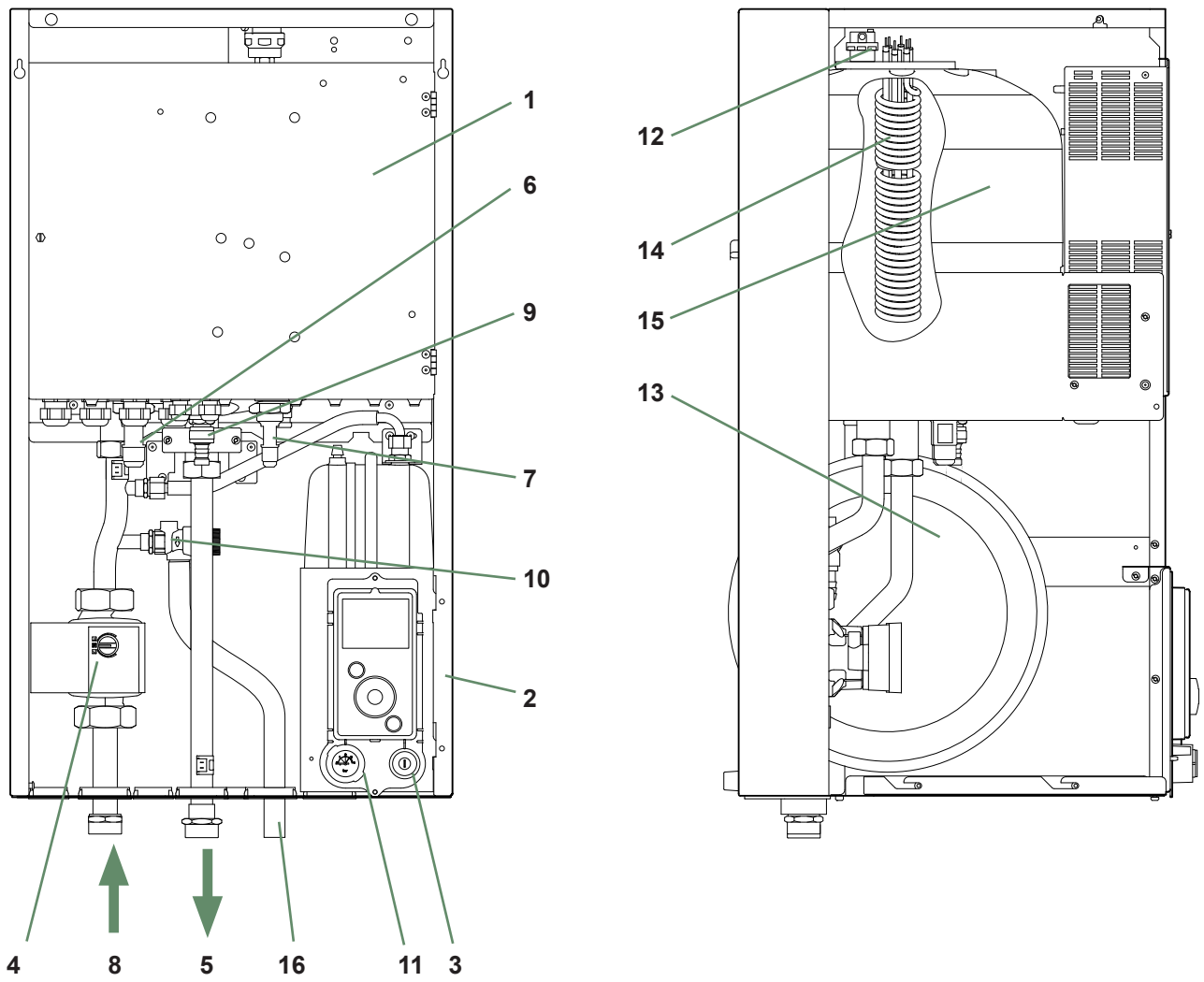

Key:

- 1 - Electric box.
- 2 - Controller / User interface.
- 3 - Start/stop switch.
- 4 - Heating circulation pump.
- 5 - Heating flow.
- 6 - "Gas" refrigeration connection.
- 7 - "Liquid" refrigeration connection.
- 8 - Heating return.

- 9 - Drain valve.
- 10 - Safety valve.
- 11 - Pressure gauge.
- 12 - Automatic bleeder valve.
- 13 - Expansion vessel.
- 14 - HP electrical backup.
- 15 - Heat exchanger.
- 16 - Drain pipe.

fig. 9 - Hydraulic unit components

► Operating principle

The heat pump transmits the energy contained in the surrounding air into the dwelling to be heated.

The heat pump consists of four main elements, in which a refrigerant (R410A) circulates.

- In the evaporator (ref. **13**, fig. 8, page 12): The calories are taken from the outside air and transmitted to the refrigerant. Because it has a low boiling point, it changes from a liquid to a vapour, even in cold weather (down to -25°C outside temperature).
- In the compressor (ref. **10**, fig. 8, page 12): The vaporised refrigerant is pressurised and takes on even more calories.
- In the condenser (ref. **14**, fig. 9, page 13): The energy of the refrigerant is transmitted to the heating circuit. The refrigerant returns to its liquid state.
- In the expansion valve (ref. **9**, fig. 8, page 12): The liquefied refrigerant is returned to a low pressure and regains its initial temperature and pressure.

The heat pump is equipped with a controller which controls the room temperature based on the outdoor temperature measurement. The room thermostat (option) provides a corrective action for the temperature control.

The hydraulic unit can be optionally fitted with an electrical backup which intervenes to provide additional heat during the coldest periods.

■ Control functions

- The heating circuit's flow temperature is controlled by the temperature control.
- Depending on the heating flow temperature, the outdoor unit's power is modulated by the "Inverter" compressor.
- Control of the backup electrical heating.
- The daily timer program is used to set the periods where the ambient temperature is comfortable or reduced.
- Summer/winter time mode switchover is automatic.
- Room sensor*: The room sensor provides a corrective action for the temperature control.
- Control of a second heating circuit*.
- Domestic hot water*: Heating timer program.
- Managing cooling*.

* Where the heat pump is fitted with options and associated kits.

■ Protective functions

- Anti-legionella cycle for domestic hot water.
- Frost protection: Frost protection cuts in if the heating circuit's flow temperature falls below 5°C (provided that the heat pump's electrical power supply is not interrupted).

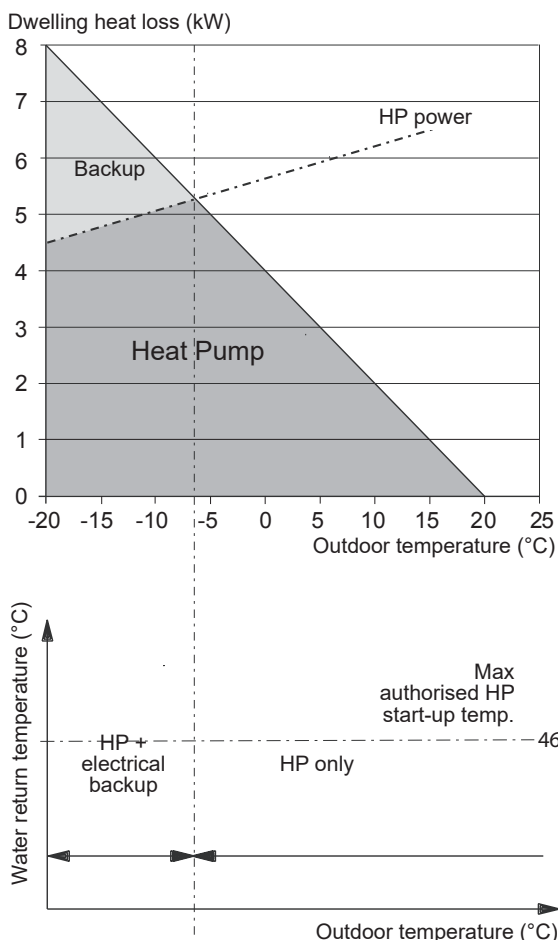

fig. 10 - Examples and operating limits

■ Domestic hot water (DHW) operating principle

Two domestic hot water (DHW) temperatures can be set: comfort and reduced.

The default DHW program is set to the comfort temperature between 00:00 and 05:00 and between 14:30 and 17:00 and to the reduced temperature for the rest of the day. This optimises electrical consumption while ensuring comfortable heating and water temperatures.

The reduced temperature setpoint may be useful to avoid restarting the DHW too often and for too long during the day.

The production of domestic hot water (DHW) is started when the temperature in the tank drops to 7°C below the temperature setpoint.

The heat pump produces the domestic hot water, which is then additionally heated, if required, by the tank's electrical backup. To ensure a DHW setpoint over 55°C, the electrical backup heating must be left on.

Depending on the setting, the comfort temperature can be reached 24h/day or only at night or following the DHW program.

If the contract signed with the energy provider includes a day/night tariff, the electrical backup is subject to the supplier's power tariff and the comfort temperature may only be reached at night.

If no particular contract has been signed, the comfort temperature can be reached at any time, including during the day.

The production of DHW takes priority over heating; nevertheless the production of DHW is managed by cycles that regulate the amount of time assigned to heating and production of DHW in the event of simultaneous demand.

Anti-legionella cycles can be programmed.

■ Fan convectors with integrated control system

Do not use a room sensor in the area in question.

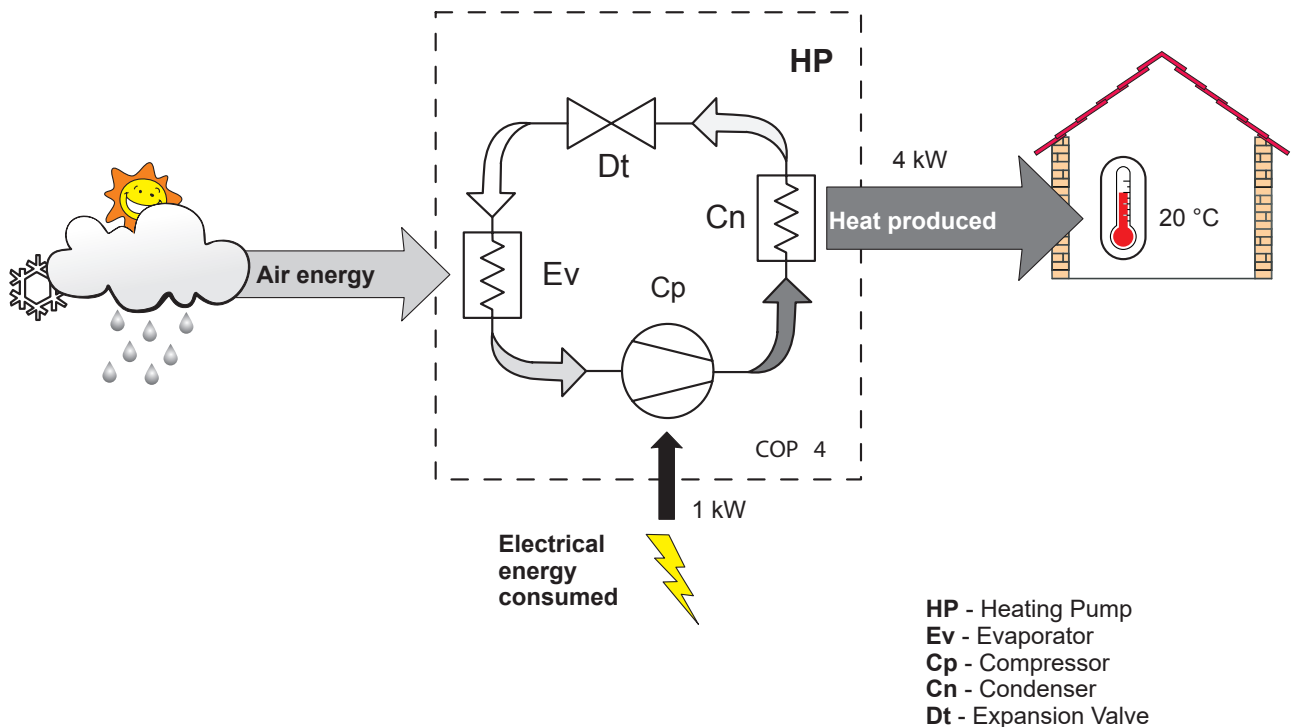

fig. 11 - Heat pump operating principle

► Installation of refrigeration connections



Bend the pipes into position and make holes for them through the floor or walls either with their protective caps in place or after brazing.

Keep the protective caps in place or ends brazed until the appliance is commissioned.

The outdoor unit must be connected to the hydraulic unit **only with brand new separately insulated copper connections** (refrigerant quality).

Maintain the same pipe diameters (fig. 19).

Observe the maximum and minimum distances between the hydraulic unit and the outdoor unit (fig. 19, page 24); the guarantee of performance and the service lifespan of the system depend on this.



The minimum length of the refrigeration connections for correct operation is 5 m.

The appliance's warranty will be void if it is operated with refrigeration connections less than 5 m long (tolerance +/- 10%).

If the refrigeration connections are exposed to weathering or UV radiation and the insulation is not resistant, protection must be provided.

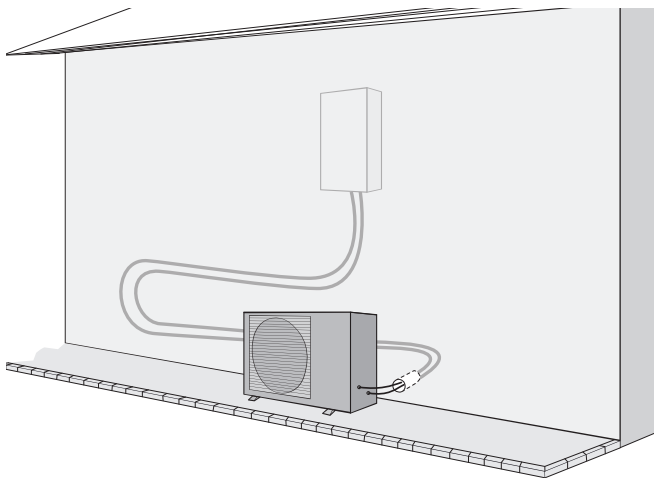

fig. 12 - Example of recommendation for layout of refrigeration connections



A series of horizontal dotted lines spanning the width of the page, providing a guide for handwriting practice.

► Installation of the outdoor unit

▼ Installation precautions



The outdoor unit must only be installed outside. If a shelter is required, it must have broad openings on all 4 sides and installation clearances must be observed.

- Choose the location of the appliance after discussion with the client.
- We recommend choosing a site that is sunny but sheltered from strong cold prevailing winds.
- The unit must be easily accessible for future installation and maintenance work (page 20).
- Ensure that connections to the hydraulic unit can be made easily.
- The outdoor unit is able to withstand bad weather but avoid installing it in a position where it is likely to be exposed to significant dirt or flowing water (under a defective gutter for example).

- Water may flow out of the outdoor unit when it is operating. Do not install the unit on a paved terrace; choose a well-drained location (e.g. gravel or sand). If installation is carried out in an area where the temperature stays below 0°C for long periods, check that the presence of ice does not present any danger. A drainage pipe can also be connected to the outdoor unit (see fig. 14).
- Nothing should obstruct the air circulation through the evaporator and out from the fan (fig. 13).
- Keep the outdoor unit away from heat sources and flammable products.
- Make sure that the unit does not disturb the surrounding area or inhabitants (noise level, draught, low temperature of the ejected air freezing the plants in its path).

A ≥ 150 mm	F ≥ 600 mm
B ≥ 200 mm	G ≥ 1000 mm
C ≥ 250 mm	H ≥ 1500 mm
D ≥ 300 mm	J ≥ 2000 mm
E ≥ 500 mm	K ≥ 3000 mm

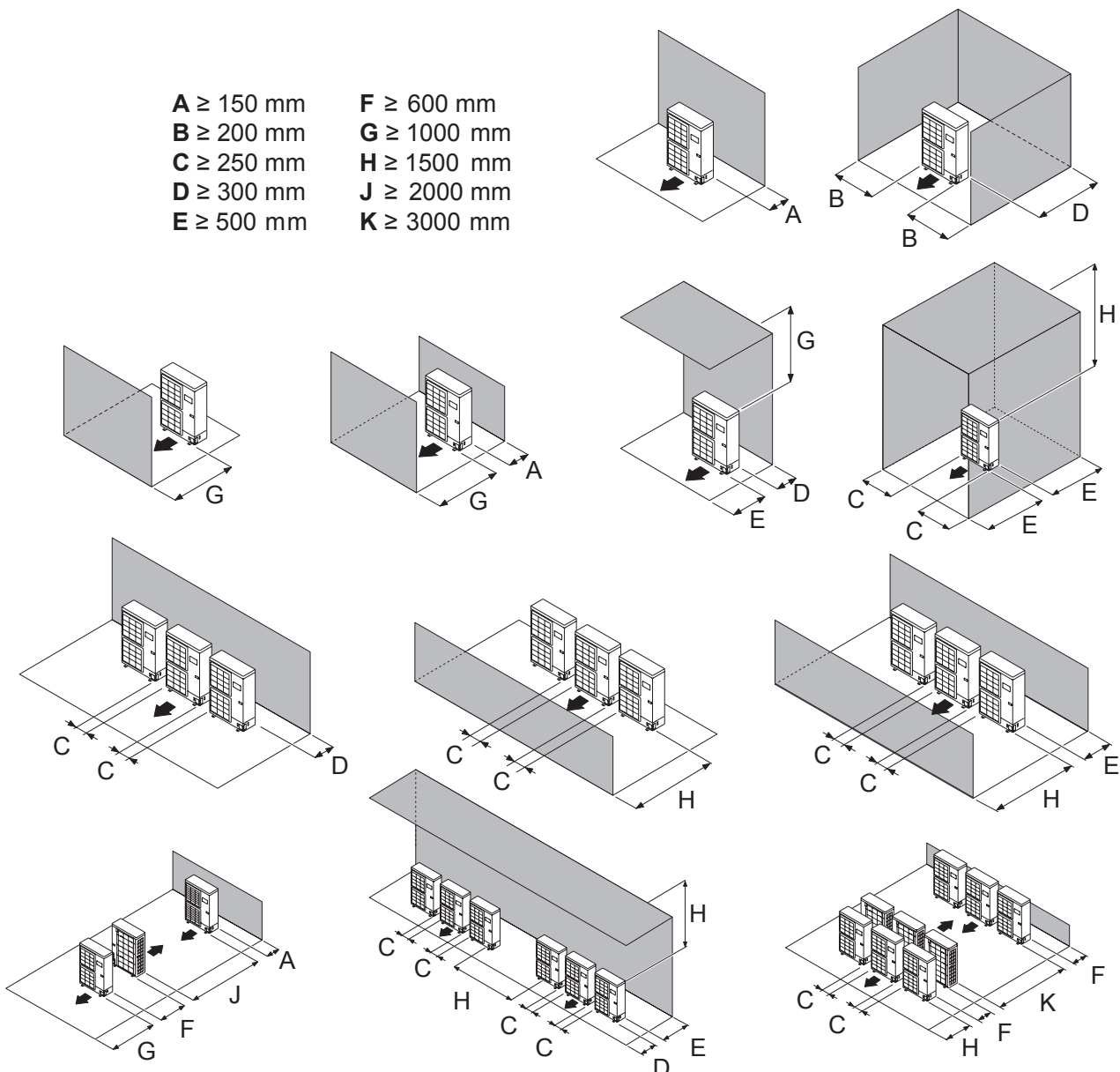

fig. 13 - Minimum installation clearances around the outdoor unit (all models)

- The surface on which the appliance is installed must:
 - Be permeable (soil, gravel, etc.).
 - Support its weight easily.
 - Allow a solid fastening base,
 - Not transmit any vibration to the dwelling. Anti-vibratory blocks are available as an option.
- The wall bracket cannot be used where it is likely to transmit vibrations. Installing the unit on the ground is preferred.

▼ Positioning Outdoor Unit

The outdoor unit must be raised at least 50 mm above ground level. In areas prone to snow, this height should be increased but should not exceed 1.5 m (figure 12).

- Fasten the outdoor unit by means of screws and rubber tightening or toothed lock washers to prevent them from coming loose.



In areas with heavy snowfall, if the intake and outlet of the outdoor unit is blocked with snow, heating may become difficult and a failure is likely to occur.

Construct a canopy or place the unit on a high stand (local configuration).

- Place the unit on a solid stand in order to minimise impacts and vibrations.
- Do not place the unit directly on the ground as this will cause problems.

▼ Condensate drain pipe



The outdoor unit can generate a large volume of water (called condensate).

If the use of a drain pipe is necessary:

- Use the elbow provided (C) and connect a 16 mm-diameter hose for draining the condensate.
- Use the plug(s) provided (B) to block the opening of the condensate drain pan.

Allow for the condensate to flow away under the force of gravity (waste water, rain water, gravel bed).



If installation is carried out in an area where the temperature stays below 0°C for long periods, equip the drain pipe with trace heating to avoid it icing up. Trace heating must heat not only the drain pipe but also the bottom of the appliance's condensate collection tank.

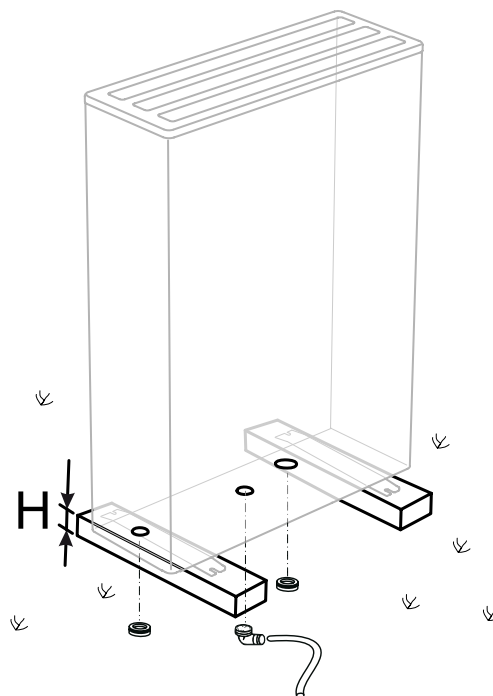

* In areas with heavy snowfall, (H) must be higher than the average snow layer.

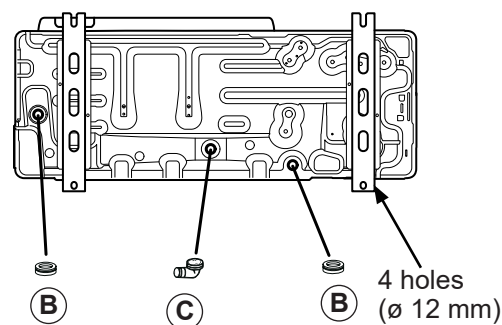
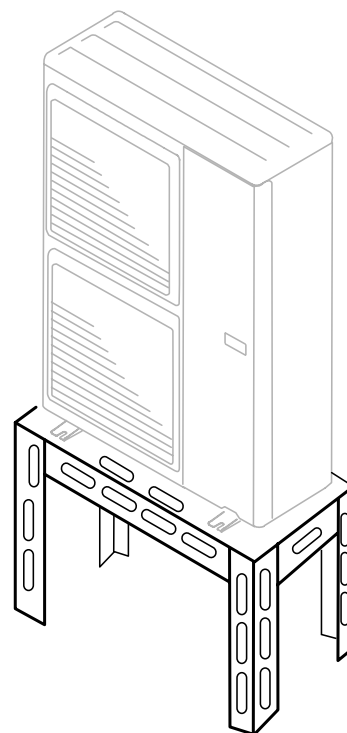
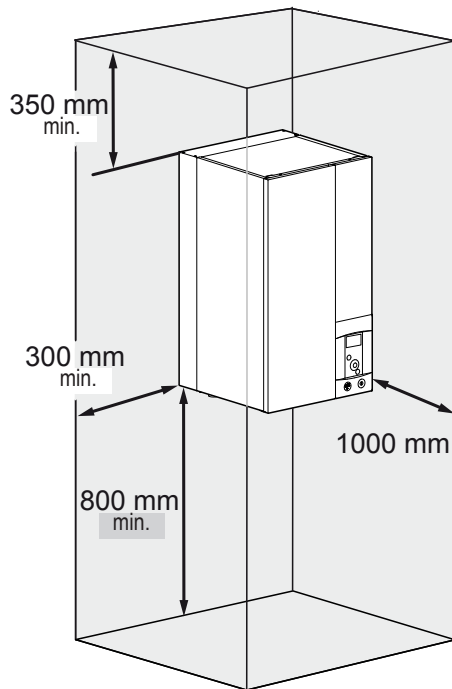

fig. 14 - Installation of the outdoor unit
evacuation of condensates

► Installation of the hydraulic unit

▼ Installation precautions

- Choose the location of the appliance after discussion with the client.
- The installation space should comply with current regulations.
- To facilitate maintenance and allow access to the various parts, we recommend that you provide sufficient space all the way around the hydraulic unit.



- In accordance with EN 378-1 - 2017 standard (Refrigerating systems and heat pumps - Safety and environmental requirements), the system's hydraulic unit and all refrigeration connections passing through inhabited areas must comply with the minimum room volume requirements shown hereafter.

The minimum volume of a room (in m³) is calculated using the formula: "fluid fill load" (in kg) / 0.39.

Alternatively, you must ensure that

- the location has natural ventilation through another room where the combined volume of the two rooms is greater than "liquid fill load" (in kg) / 0.39 kg/m³. The opening between the two rooms must have a door clearance of at least 1 cm.
- or that the location is mechanically ventilated.

Be careful not to bring flammable gas near the heat pump during installation, in particular when brazing is required. The appliances are not fireproof and should not therefore be installed in an explosive environment.



To prevent risks of humidity in the exchanger, it is pressurized with nitrogen.



- To avoid condensation inside the condenser, remove the refrigeration circuit caps **only when making the refrigeration connections**.
- If the refrigeration connection is only performed at the end of the installation, make sure that the refrigeration circuit caps* remain in place and tight throughout the installation.
* (Hydraulic unit side and outdoor unit side).
- After each maintenance operation on the refrigeration circuit and before the final connection, take care to put the caps back in position to avoid any pollution of the refrigeration circuit (sealing with adhesive is prohibited).

▼ Positioning the hydraulic unit

- Fix the bracket **S** securely (4 screws and plugs) to a strong, flat wall (not a light partition) ensuring that it is correctly levelled.
- Hook the appliance onto its bracket **S**.

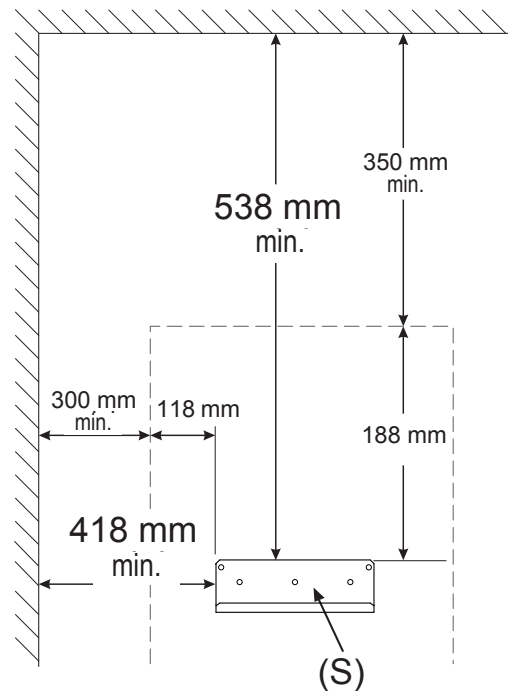

fig. 15 - Mounting bracket

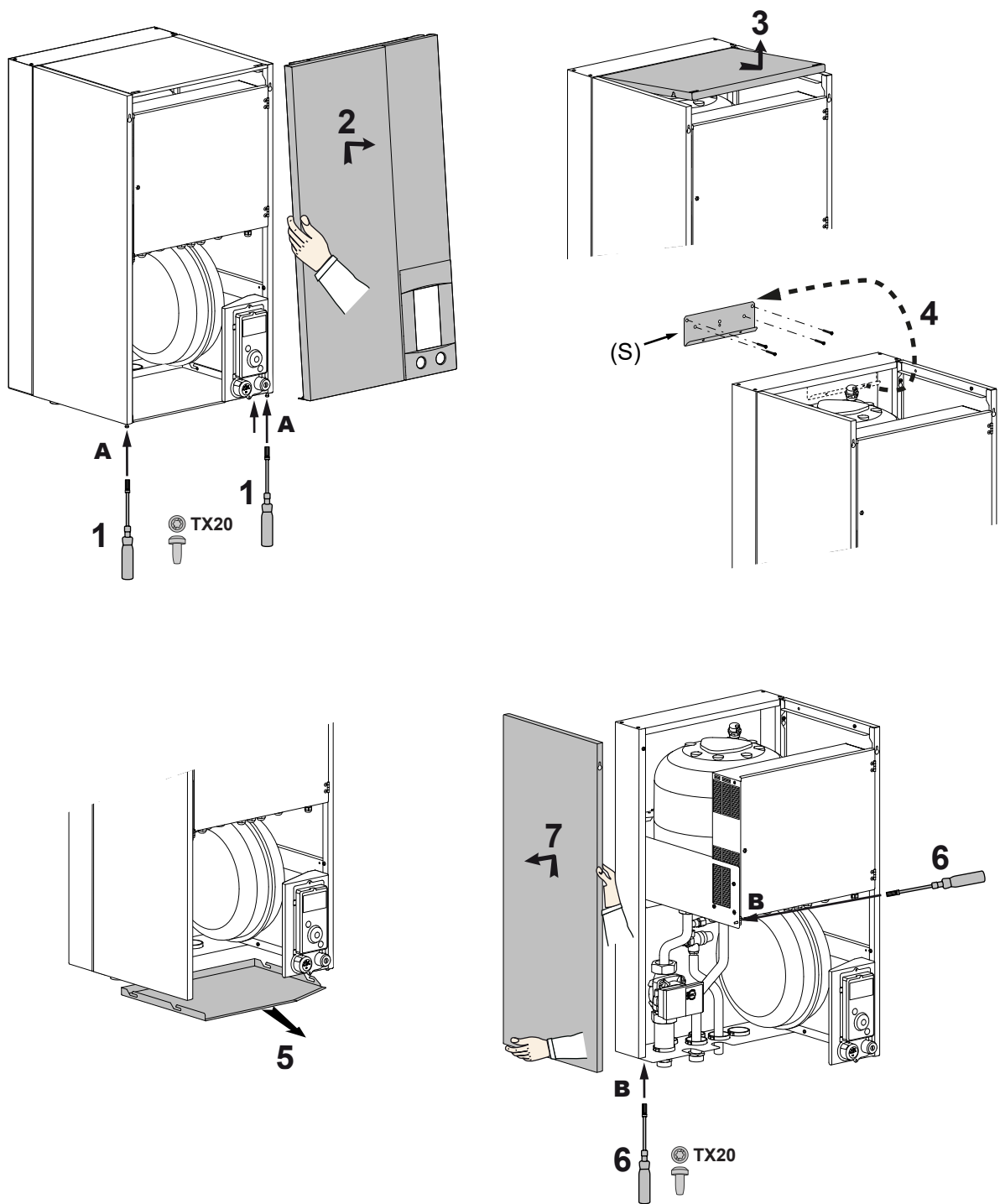

fig. 16 - Removing the casing

Refrigeration connections and filling the installation with gas

This appliance uses refrigerant R410A.

Comply with the legislation on handling of refrigerants.

► Rules and precautions



Connections must be made on the same day the installation is filled with gas (see para. "Filling the installation with gas", page 26).

■ Minimum tools required

- Set of pressure gauges (*Manifold*) with hoses exclusively designed for HFCs (Hydrofluorocarbons).
- Vacuum gauge with isolation valves.
- Vacuum pump specifically for HFCs (using a standard vacuum pump is allowed if, and only if, it is fitted with a non-return valve on the suction side).
- Flaring tool, Pipe-cutter, Deburring tool, Spanners.
- Certified refrigerant leak detector (sensitivity 5g/year).

Using tools that have been in contact with HCFCs (R22 for example) or CFCs is prohibited.



The manufacturer declines any liability with regard to the warranty if the above instructions are not observed.

• Flared connections



Lubricating with mineral oil (for R12, R22) is prohibited.

- Lubricate only with polyolester oil (POE). If POE is not available, fit without lubrication

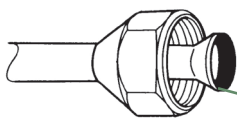

Coat the flared surface with **POE refrigeration oil**.
Do not use mineral oil.

• Brazing the refrigeration circuit (if necessary)

- Silver brazing (40% minimum recommended).
- Brazing only with dry nitrogen internal flux.

■ Other remarks

- After each maintenance operation on the refrigeration circuit and before final connection, take care to put the caps back in position to avoid any pollution of the refrigeration circuit.
- To eliminate any filings getting into the pipes, use dry nitrogen to avoid introducing any humidity that may adversely affect the appliance's operation. In general, take every precaution to avoid humidity penetrating into the appliance.
- Proceed with thermal insulation of the gas and liquid pipes to avoid any condensation. Use pipe insulators resistant to temperatures over 90°C. In addition, if the humidity level in areas where the refrigerant pipes are installed is expected to exceed 70%, protect the pipes with pipe insulators. Use an insulating material thicker than 15mm if the humidity level reaches 70 ~ 80%, and an insulating material thicker than 20mm if the humidity exceeds 80%. If the recommended thicknesses are not observed under the conditions described above, condensation will form on the surface of the insulation material. Lastly, use insulating sleeves whose thermal conductivity will be less than or equal to 0.045 W/mK if the temperature is equal to 20°C. The insulation must be impermeable in order to withstand the passage of vapour during the defrosting cycles (glass wool is prohibited).

► Shaping the refrigeration pipes

▼ Bending

The refrigeration pipes must be shaped only on a bending machine or with a bending spring in order to avoid any risk of crushing or breaking them.

Remove the insulation material from the section of pipe to be bent.



Do not bend copper to an angle greater than 90°.

Never bend pipes more than 3 times in the same place otherwise traces of fracturing may appear (hardening of the metal).

▼ Creating the flarings

- Cut the pipe to an appropriate length with a pipe-cutter without damaging it.
- Carefully deburr it, holding the pipe pointing downward to avoid introducing filings into the pipe.
- Remove the flared connection nut situated on the valve to be connected and slide the pipe into the nut.
- Proceed to flare it, letting the pipe protrude out of the flaring tool's tube.
- After flaring, check the state of the working radius (**L**). This must not present any scratches or signs of fracturing. Also check the dimension (**B**).

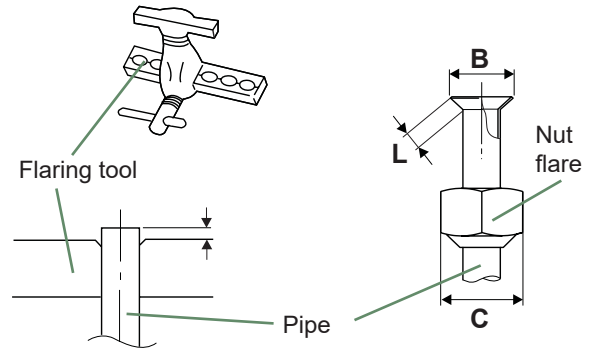

Pipe \varnothing	Dimensions in mm		
	L	B $^{0}/_{-0.4}$	C
9.52 (3/8")	2.5 to 2.7	13.2	22
15.88 (5/8")	2.9 to 3.1	19.7	29

fig. 17 - Flaring of the flared connections

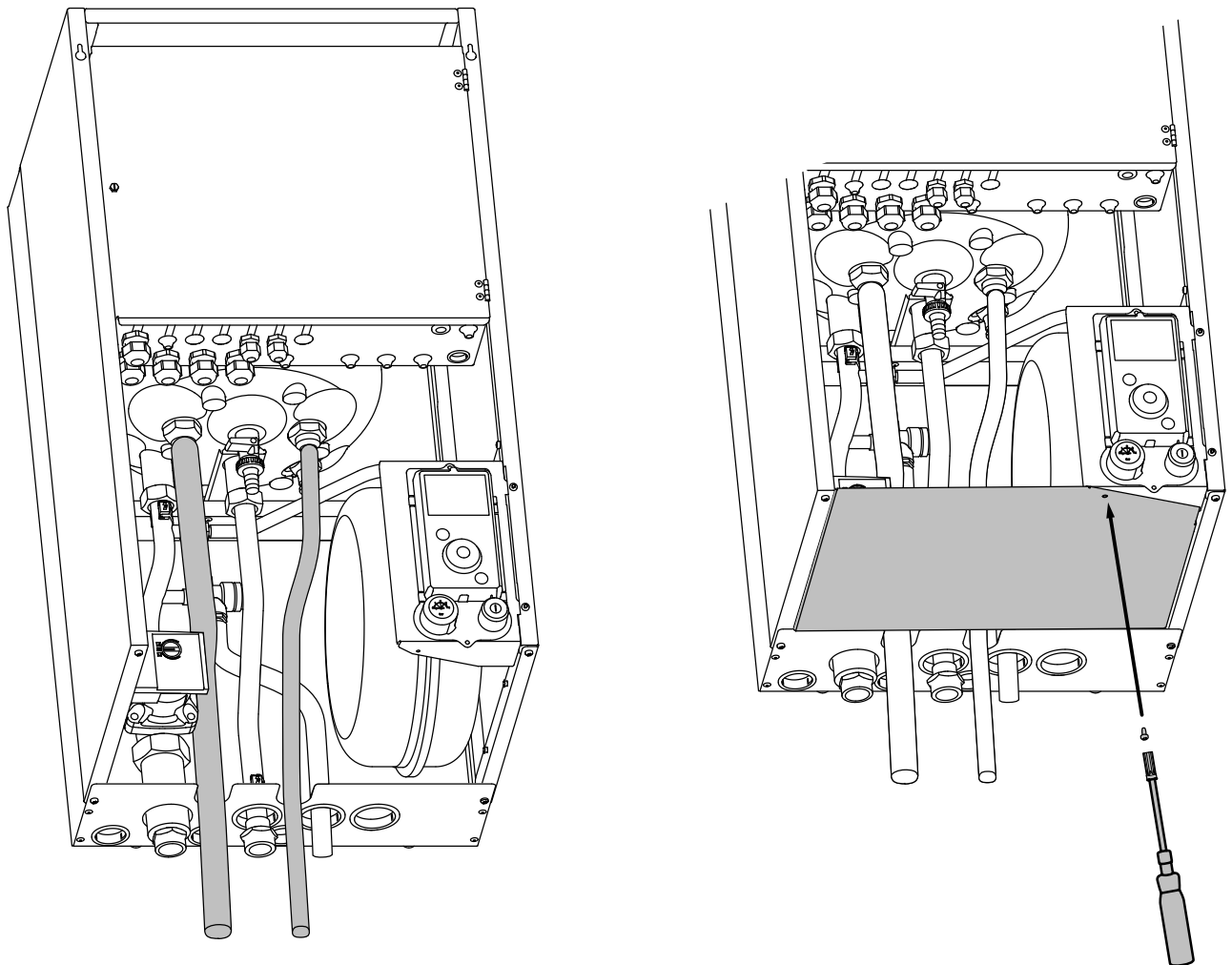

fig. 18 - Feeding through flared connections

HP model	Alféa Excellia A.I. single and 3 phase	
	gas	liquid
Outside unit connections	5/8"	3/8"
Refrigeration connections	Diameter:	(D1) 5/8" (D2) 3/8"
	Minimum length (L)	5
	Maximum length* (L)	15
	Maximum length** (L)	20
	Maximum Height Difference** (D)	15
Hydraulic unit connections	5/8"	3/8"

* : Without additional filling of R410A.

** : Taking into account a possible additional fill of refrigerant R410A (see "Additional filling", page 28).

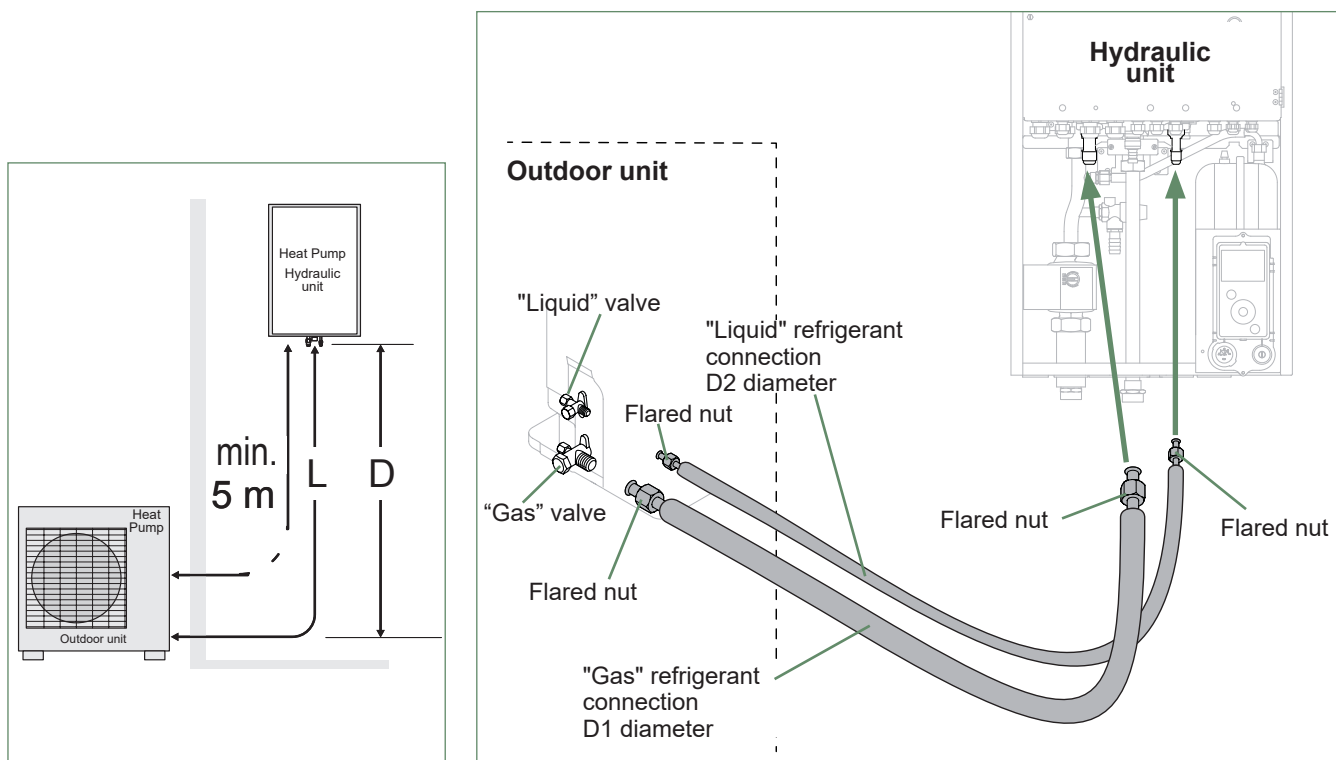

fig. 19 - Refrigeration connections (authorised diameters and lengths)

► Checks and connection



The refrigeration circuit is very sensitive to dust and humidity: check that the area around the connection is clean and dry before removing the plugs protecting the refrigeration connectors.

Indicated blowing value: 6 bar for minimum 30 seconds for connection of 20 m.

Checking the gas connection (large diameter).

① Connect the gas connection to the Outdoor Unit. Blow dry nitrogen into the gas connection and inspect its end:

- If water or impurities emerge, use a brand new refrigeration connection.

② Otherwise, proceed with flaring and connect the refrigeration connection to the Outdoor Unit immediately.

Checking the liquid connection (small diameter).

③ Connect the liquid connection to the Hydraulic Unit. Blow nitrogen into the **gas-condenser-liquid connection** system and inspect its end (Outdoor Unit side).

- If water or impurities emerge, use a brand new refrigeration connection.

- Otherwise, proceed with flaring and connect the refrigeration connection to the Outdoor Unit immediately.



Take particular care to position the tube opposite its connector so as not to risk damaging the threads. A properly aligned connector can be attached easily by hand without much force being required.

- Remove the plugs from the pipes and the refrigeration connections.

- **Warning!** Avoid positioning the gas pipe in front of the pump.

- Comply with the indicated tightening torques.

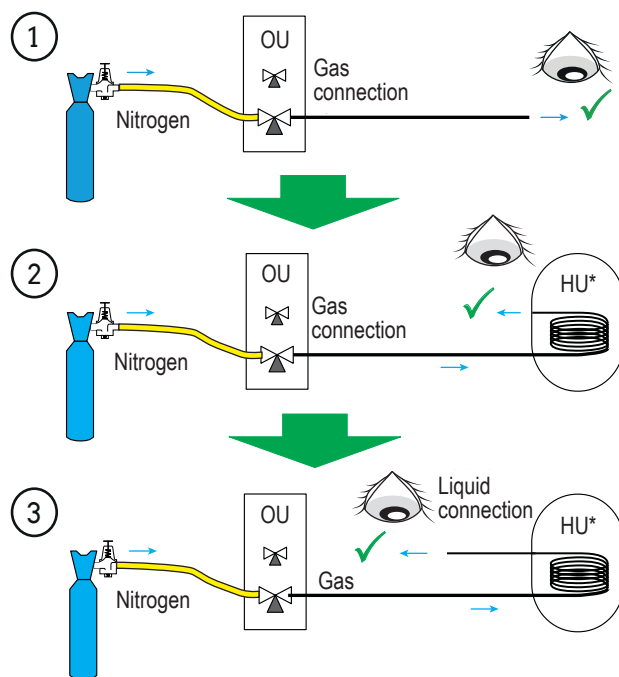
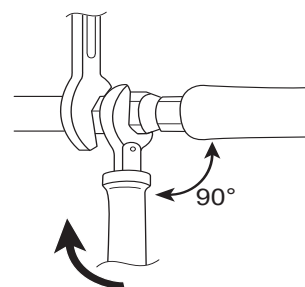

fig. 21 - Checking refrigeration connections

Holding spanner

Torque wrench



Designation	Tightening torque
Flared nut 9.52 mm (3/8")	32 to 42 Nm
Flared nut 15.88 mm (5/8")	63 to 77 Nm
Plug (A) 3/8"	20 to 25 Nm
Plug (A) 5/8"	30 to 35 Nm
Plug (B) 3/8", 5/8"	10 to 12 Nm

Plug (A) and (B) : see fig. 22, page 27.

fig. 20 - Tightening torques

► Filling the installation with gas



This operation is reserved for installers familiar with the legislation for handling refrigerants.

Creating a vacuum with a calibrated vacuum pump is essential (see APPENDIX 1).

Never use equipment used previously with any refrigerant other than a HFC.

Only remove the refrigeration circuit caps when performing the refrigeration connections.

If the outdoor temperature is below +10°C:

- You must use the triple evacuation method (see APPENDIX 2).
- We recommend installing a dehydrator filter (and this is highly recommended if the outdoor temperature is below +5°C).

APPENDIX 1

Method for calibrating and checking a vacuum pump

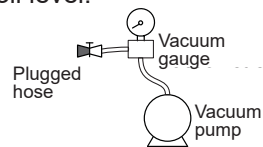
- Check the vacuum pump's oil level.
 - Connect the vacuum pump to the vacuum gauge as shown in the diagram.
- 
- Pump down for 3 minutes.
 - After 3 minutes, the pump reaches its threshold vacuum limit and the vacuum gauge's needle stops moving.
 - Compare the obtained pressure value against the table of values. Depending on the temperature, this pressure should be lower than that shown in the table.
- => If this is not the case, replace the gasket, hose or pump.

T °C	5°C < T < 10°C	10°C < T < 15°C	15°C < T
Pmax			
- bar	0.009	0.015	0.020
- mbar	9	15	20

APPENDIX 2

Triple Evacuation Method

- Connect the *Manifold* high-pressure hose to the filling hole (gas connection). A valve must be fitted to the vacuum pump's hose so you can shut it off.

- a) Create a vacuum until the desired value is reached and maintain this value for 30 mins (see table in APPENDIX 1),

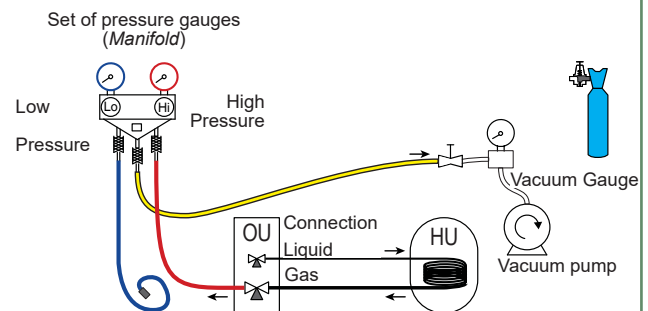

- b) Switch off the vacuum pump, close the valve at the end of the service hose (yellow), connect this hose to the expansion valve on the nitrogen bottle, fill to 2 bar, close the hose's valve again,

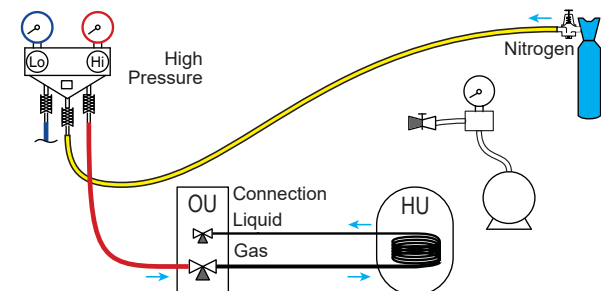

- c) Connect this hose to the vacuum pump again, switch it on and slowly open the hose's valve.

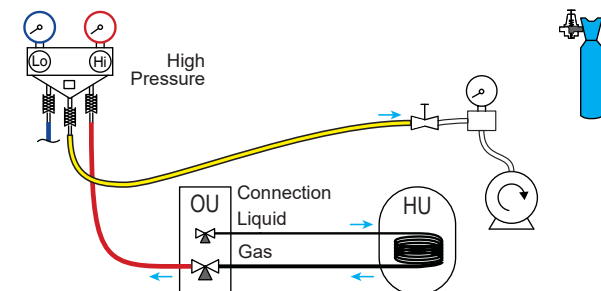

- d) Repeat this operation at least three times.

Remember: performing these operations using refrigerant is strictly prohibited.

▼ Seal test

- Remove the protective plug (B) from the filling hole (Schrader) in the gas valve (large diameter).
- Connect the high pressure hose from the *Manifold* to the filling hole (fig. 22).
- Connect the nitrogen bottle to the *Manifold* (only use dehydrated nitrogen type U).
- Fill the refrigeration circuit with nitrogen to maximum 10 bar (**gas-condenser-liquid connection system**).
- Maintain this pressure in the circuit for 30 minutes.

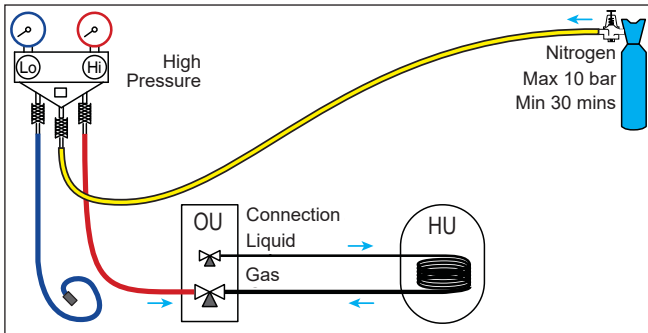

- If a pressure drop occurs, bring it back down to 1 bar and look for leaks with a leak detector, repair and repeat the test.

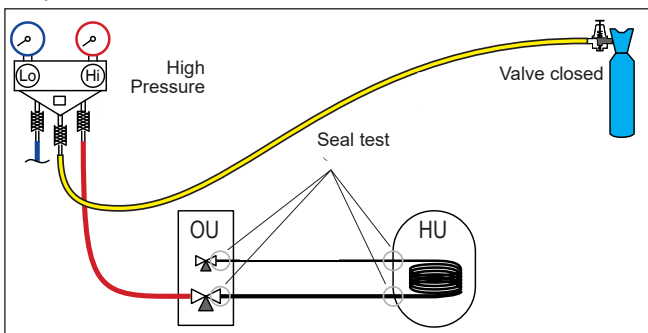

- Once the pressure is steady and there are no leaks, empty the nitrogen by leaving the pressure above atmospheric pressure (between 0.2 and 0.4 bar).

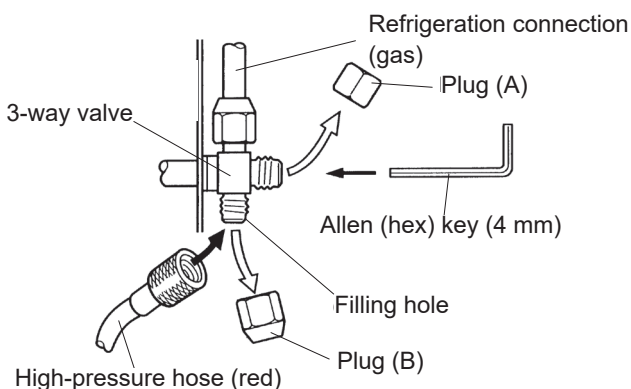

fig. 22 - Connecting the hose to the gas valve

▼ Creating a vacuum



The triple evacuation method (APPENDIX 2) is strongly recommended for any installation and especially when the outdoor temperature is below 10°C.

- If necessary, calibrate the *Manifold* pressure gauge(s) to 0 bar. Adjust the vacuum gauge to current atmospheric pressure (≈ 1013 mbar).
- Connect the vacuum pump to the *Manifold*. Connect a vacuum gauge if the vacuum pump is not equipped with one.

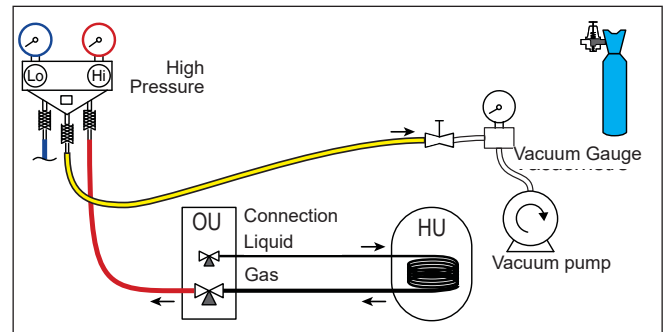

- Create a vacuum until the residual pressure* in the circuit falls below the value given in the following table (* measured with the vacuum gauge).

T °C	5°C < T < 10°C	10°C < T < 15°C	15°C < T
Pmax			
- bar	0.009	0.015	0.020
- mbar	9	15	20

- Let the pump continue to operate for another 30 minutes minimum after reaching the required vacuum.
- Close the *Manifold* valve, then stop the vacuum pump **without disconnecting any of the hoses in place**

▼ Filling with gas



If additional filling is required, do it before filling the hydraulic unit with gas. Refer to paragraph "Additional filling", page 28.

- Remove the access plugs (A) from the valve controls.
- First of all fully open the liquid valve (small) and then the gas valve (large) using an Allen (hex) key (anti-clockwise direction) without using excessive force against the stop.
- Quickly disconnect the hose from the *Manifold*.
- Refit the 2 original caps (be sure they are clean) and tighten them to the recommended tightening torque indicated in the table fig. 20, page 25. A seal is achieved in the caps only with metal to metal.

The outdoor unit does not contain any additional refrigerant allowing the installation to be bled.

Bleeding by flushing is strictly forbidden.

▼ Final sealing test

The sealing test must be carried out using a certified gas detector (sensitivity of 5g/year).

Once the refrigeration circuit has been gassed as described above, check that all the refrigeration connectors are gas-tight (4 connectors). If the flarings have been made correctly, there should be no leaks. If necessary, check the seal of the refrigeration valve caps.

If the event of a leak:

- Return the gas to the outdoor unit (pump down). The pressure should not drop below atmospheric pressure (0 relative bar read on the *Manifold*) so as not to contaminate the recovered gas with air or moisture.
- Redo the connection,
- Restart the commissioning procedure.

▼ Additional filling

	50 g of R410A for every additional 1 metre	
Length of the connections	15 m	20 m max.
Additional load	None	250 g

The amount needed to fill the outdoor units corresponds to the maximum distances between the outdoor unit and the hydraulic unit as defined here page 24. If the distances are greater, an additional amount of R410A is required. For each type of appliance, this additional amount depends on the distance between the outdoor unit and the hydraulic unit. Any additional filling with R410A must be carried out by an approved specialist.

• **Example of additional fill:**

An outdoor unit which is 17 m away from the hydraulic unit will require an additional fill of:

$$\text{Additional fill} = (17 - 15) \times 50 = 100 \text{ g}$$

Filling must be carried out after creating a vacuum and before gassing the hydraulic unit, as follows:

- Disconnect the vacuum pump (yellow hose) and connect a bottle of R410A in its place **in the fluid extraction position**.
- Open the bottle's valve.
- Bleed the yellow hose by loosening it slightly on the *Manifold* side.
- Place the bottle on scales with a minimum accuracy of 10g. Note the weight.
- Carefully open the blue valve slightly and check the value shown on the scales.
- As soon as the value displayed has dropped by the value for the calculated additional fill amount, close the bottle and disconnect it.
- Quickly disconnect the hose connected to the appliance.
- Proceed to fill the hydraulic unit with gas.

Only use R410A!

Only use tools suitable for R410A (set of pressure gauges).

Always fill in the liquid phase.

Never exceed the maximum length or difference in level.

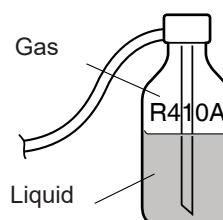

fig. 23 - Gas bottle R410A

▼ Recovering the refrigerant in the outdoor unit



Before performing any maintenance, make sure that all power supplies have been cut off.

Stored energy: after cutting off the power supplies, wait for 1 minute before accessing the internal parts of the equipment.

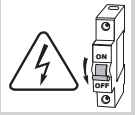

Perform the following procedures to collect the refrigerant.

- **1-** Switch the start/stop switch to the 0 position (mark **3**, fig. 9, page 13). Disconnect the outdoor unit's power supply.
- **2-** Remove the front panel. Open the power control box. Then turn **ON** the **DIP SW1** on the interface board,
- **3-** Reconnect the power supply. Switch the start/stop switch to position 1. (The green and red LEDs start flashing; 1s on / 1s off). The outdoor unit begins cooling operation about 3 minutes after being switched on.
- **4-** The circulation pump starts.
- **5-** Close the liquid valve on the outdoor unit **maximum** 30 secs after the outdoor unit starts.
- **6-** Close the gas valve on the outdoor unit when the pressure is below 0.02 relative bar read on the *Manifold*, or 1-2 minutes after the liquid valve has been closed, while the outdoor unit continues to operate.
- **7-** Disconnect the power supply.
- **8-** Recovery of the refrigerant is complete.

Notes:

- The pump down operation cannot be activated even if **DIP SW1** is set to **ON** while the heat pump is in operation.
- Do not forget to switch **DIP SW1** back to **OFF** after the pump down operation has been completed.
- Select the heating mode.
- If the pump down operation fails, try the operation again by turning the machine off and opening the "liquid" and "gas" valves. Then after 2-3 minutes, restart the pump down operation.

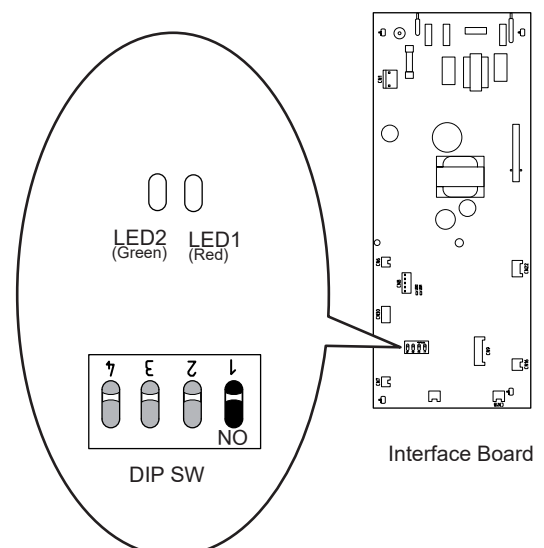

fig. 24 - Location of DIP switches and LEDs on the hydraulic unit interface board

Hydraulic connections

► Connecting the hydraulic unit to the heating circuit

▼ Flushing the installation

Before connecting the hydraulic unit to the installation, **rinse out the heating system correctly** to eliminate any particles that may affect the appliance's correct operation.

Do not use solvents or aromatic hydrocarbons (petrol, paraffin, etc.).

In the case of an old installation, provide a sufficiently large decanting pot with a drain on the return from the boiler and at the lowest point in the system in order to collect and remove any impurities.

Add an alkaline product and a dispersant to the water.

Flush the installation several times before proceeding to the final filling.

▼ Connections

The heating circulation pump is built into the hydraulic unit.

Connect the central heating pipes to the hydraulic unit correctly according to the direction of circulation.

The pipe between the hydraulic unit and the heat collector must be at least one inch in diameter (26x34 mm).

Calculate the diameter of the pipes based on flow rates and lengths of the hydraulic systems.

Tightening torque: 15 to 35 Nm.

Use union connectors to make it easier to remove the hydraulic unit.

Try to use connection hoses to avoid transmitting noise and vibrations to the building.

Connect the drains from the drain valve and the safety valve to the main sewer system.

Verify that the expansion system is correctly connected. Check the expansion vessel pressure (pre-inflated to 1 bar) and the safety valve is calibrated.

The flow rate of the installation must be at least equal to the minimum value mentioned in the specifications table "[General characteristics](#)", [page 7](#). The installation of a regulator (other than those included in our configurations) which reduces or stops the flow through the hydraulic unit is prohibited.

▼ Volume of the heating system

You must maintain the minimum installation water volume. Install a buffer tank on the return from the heating circuit in case the volume is lower than this value. Where the system is fitted with one or more thermostatic valves, you must ensure that this minimum water volume is able to circulate.

Appliance	Min. volume in litres PER CIRCUIT (excl. HP)		
	Mandatory Fan-coil	Recommendation Radiators	Recommendation Heating-cooling floor
Excellia A.I. 11	55	50	25
Excellia A.I. 14	74	66	35
Excellia A.I. tri 16	87	80	44

► Filling and bleeding the installation

Check the pipe fixings, tightness of the connectors and the stability of the hydraulic unit.

Check the direction in which the water is circulating and that all the valves are open.

Proceed to fill the installation.

Do not operate the circulation pump during filling. Open all the drain valves in the installation and the bleeder valve on the hydraulic unit to expel the air contained in the pipes.

Close the drain valves and add water until the pressure in the hydraulic circuit reaches 1 bar.

Check that the hydraulic circuit has been bled correctly.

Check there are no leaks.

After the "[□ Commissioning](#)", page 44, and once the machine has started, bleed the hydraulic unit again.



Precise filling pressure is determined by the water pressure in the installation.

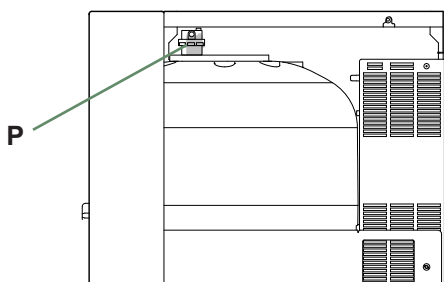
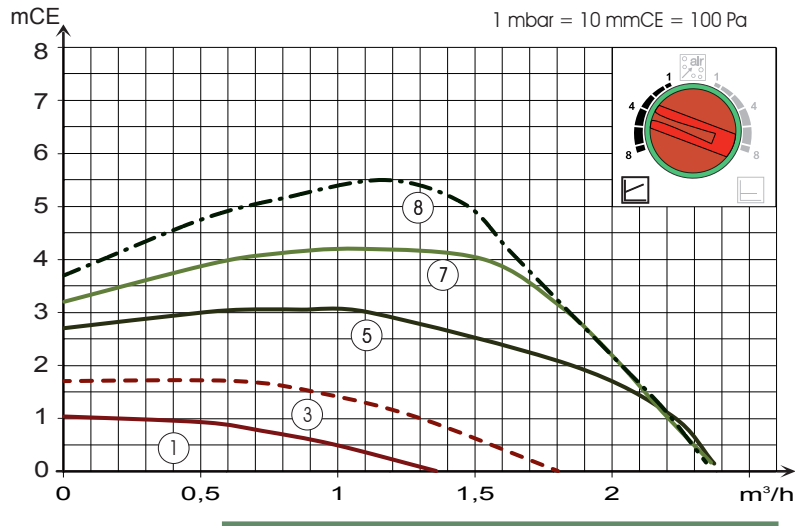

fig. 25 - Hydraulic unit automatic bleeder valve

► Heating circulation pump speed settings



Variable pressure

The circulation pump varies the water pressure depending on the flow rate.

Recommended for an installation fitted with **radiators** (particularly any system with thermostatic valves or zone solenoids).

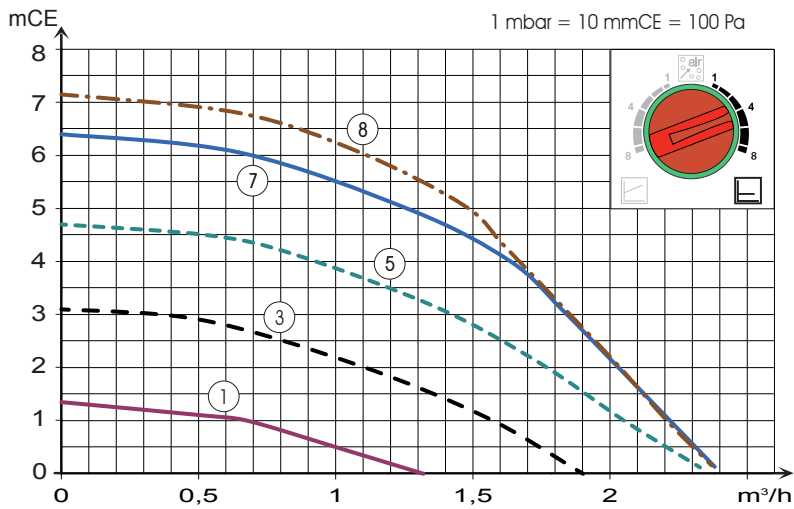
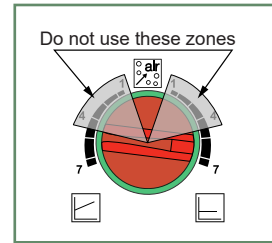

Constant pressure

The circulation pump maintains a constant water pressure whatever the flow rate.

Recommended for an installation with constant pressure drops such as an **underfloor heating system**.

fig. 26 - Available hydraulic pressures and flow rates

	OFF	LED Off: The circulation pump is not working, no power supply.
		Green LED On: The circulation pump is operating normally.
	10 min.	Green LED flashing: Venting mode in operation (10 minutes).
	Auto Test	Red/green LED flashing: Operating error with automatic restart.
		Red LED flashing: Operating error.

fig. 27 - Operating signals of the HP circulation pump

 Variable pressure

 Gas venting

 Constant pressure

Circulation pump fouled or stuck:

If the motor becomes stuck, a start-up cycle is launched.
If the motor remains stuck, it will be permanently stopped.

Cut off the power supply to the circulation pump for 30 secs in order to free it and allow a new start-up cycle to begin.

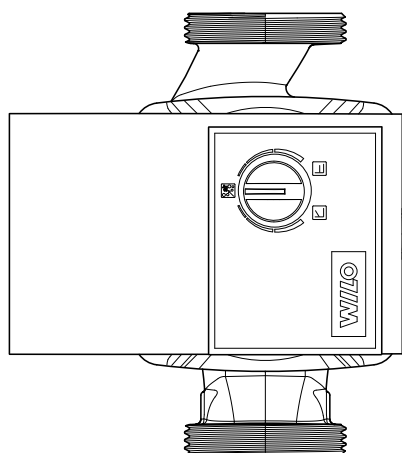
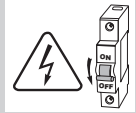

fig. 28 - Circulation pump control button

Electrical connections



Before any maintenance operation, ensure that the general power supply is switched off. Electrical installation must be performed in accordance with current regulations.



The electrical diagram for the hydraulic unit is shown on [fig. 49, page 74](#).

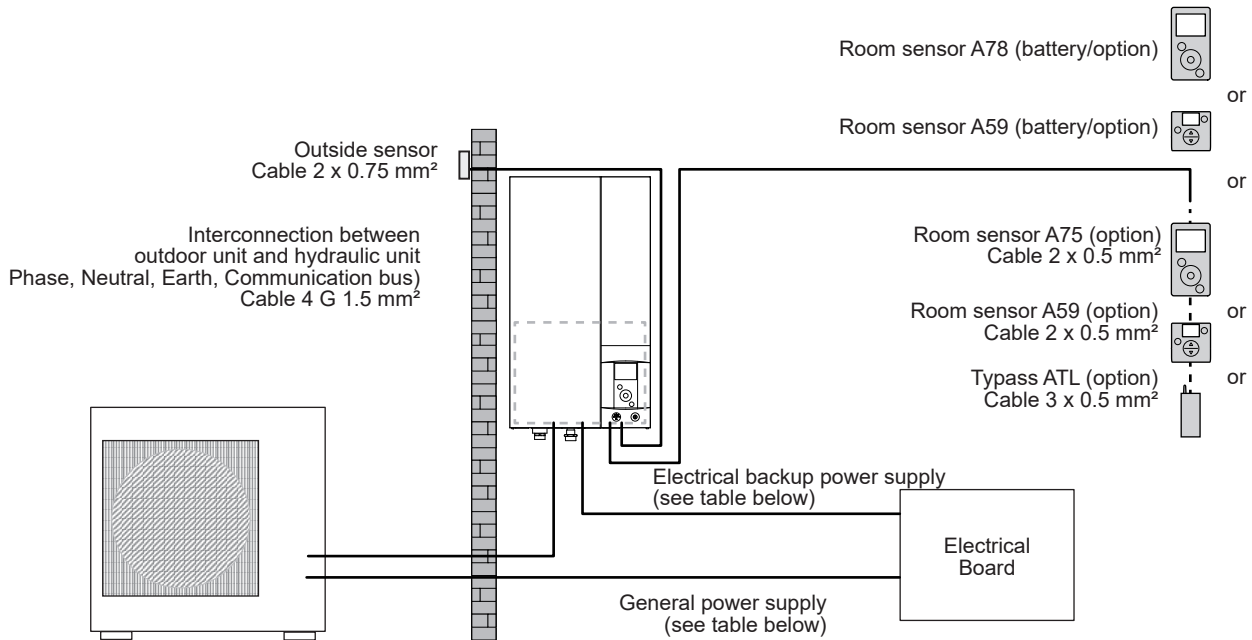

fig. 29 - Overall layout of electrical connections for a simple installation (1 heating circuit)

► Cable dimensions and protection rating

These cable dimensions are provided for information purposes only and do not exempt the installer from checking that these dimensions match requirements and comply with current standards.

• Outdoor Unit Power Supply

<i>Single phase heat pump</i>		<i>Electricity supply 230 V - 50 Hz</i>	
<i>Model</i>	<i>Max. power consumption</i>	<i>Connection cable ⁽¹⁾ (phase, neutral, earth)</i>	<i>Circuit breaker C curve</i>
Alféa Excellia A.I. 11	5060 W	3 G 6 mm ²	32 A
Alféa Excellia A.I. 14	5750 W		
<i>3 phase heat pump</i>		<i>Electricity supply 400 V - 50 Hz</i>	
<i>Model</i>	<i>Maximum power</i>	<i>Connection cable ⁽¹⁾ (3 phases, neutral, earth)</i>	<i>Circuit breaker C curve</i>
Alféa Excellia A.I. tri 16	7245 W	5 G 2.5 mm ²	20 A

• Interconnection between outdoor unit and hydraulic unit

The hydraulic unit is powered by the outdoor unit by means of a 4 G 1.5 mm² cable (phase, neutral, earth, communication bus).

• DHW power supply

The DHW section is powered directly via a 3 G 1.5 mm² cable (phase, neutral, earth).
Protection by circuit breaker (16 A, C curve).

• Electrical backup power supply

The hydraulic unit contains a electrical backup circuit (and a second optional) installed in the storage tank.

<i>Heat pump</i>	<i>Electrical backups</i>		<i>Electrical backup power supply</i>	
<i>Model</i>	<i>Power</i>	<i>Nominal current</i>	<i>Connection cable ⁽¹⁾ (phase, neutral, earth)</i>	<i>Circuit breaker C curve</i>
Alféa Excellia A.I. 11, 14	3 kW	13 A	3 G 1.5 mm ²	16 A
Alféa Excellia A.I. 11, 14 with 6 kW Backup Relay Kit	2 x 3 kW	26.1 A	3 G 6 mm ²	32 A
Alféa Excellia A.I. tri 16	9 kW	3 x 13 A	4 G 2.5 mm ²	20 A

⁽¹⁾ type cable 60245 IEC 57 or 60245 IEC 88.

► Electrical connections on the single phase outdoor unit side

Access to connection terminals:

- Remove the front plate. Remove the screws and front panel.
- Make the connections according to the diagram(s) fig. 37, page 39.

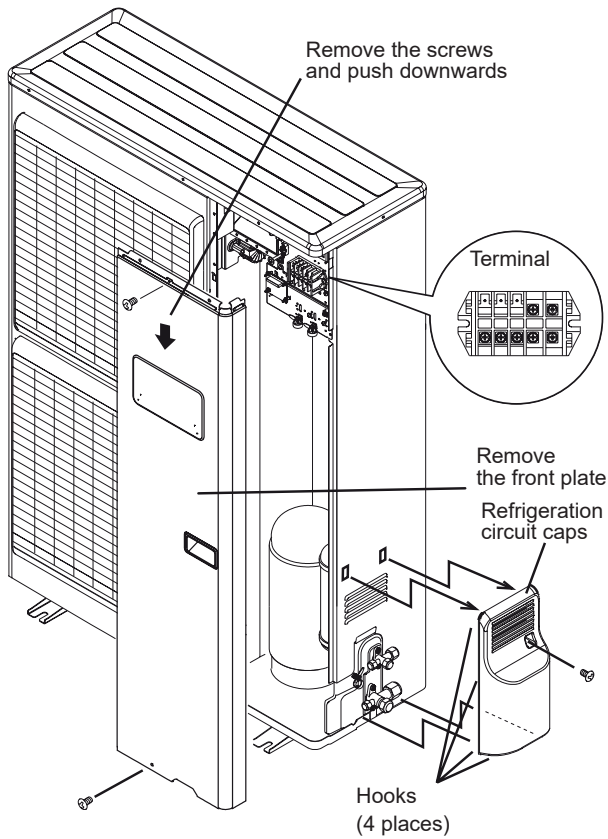

fig. 30 - Access to single phase outdoor unit's terminal block

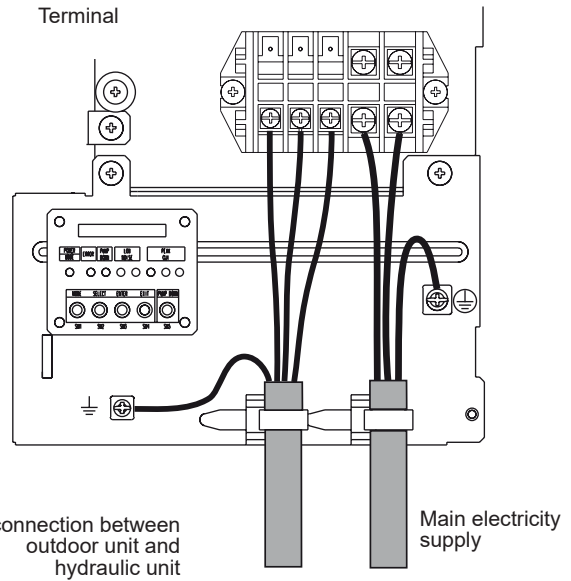

fig. 31 - Access to single phase outdoor unit's terminal block

- Use cable clamps to prevent any power cables from being disconnected accidentally.
- Use the fixing plate to keep the cables tight against the insulating plate.

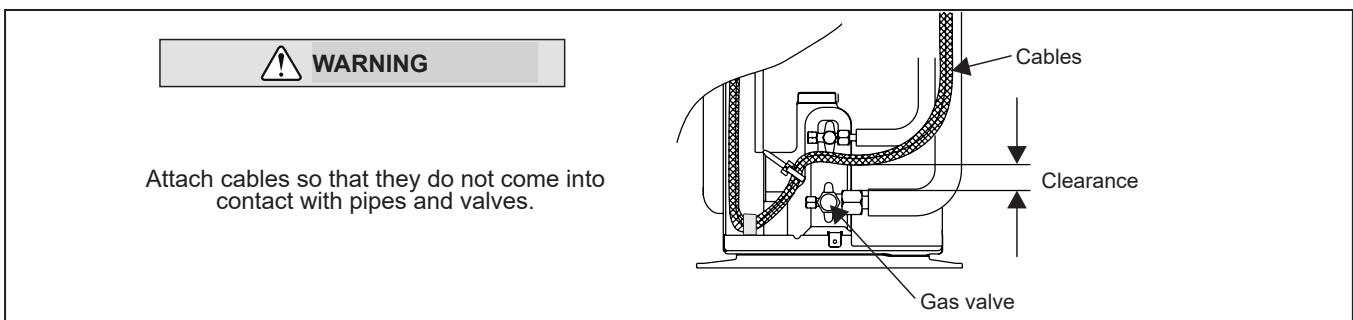
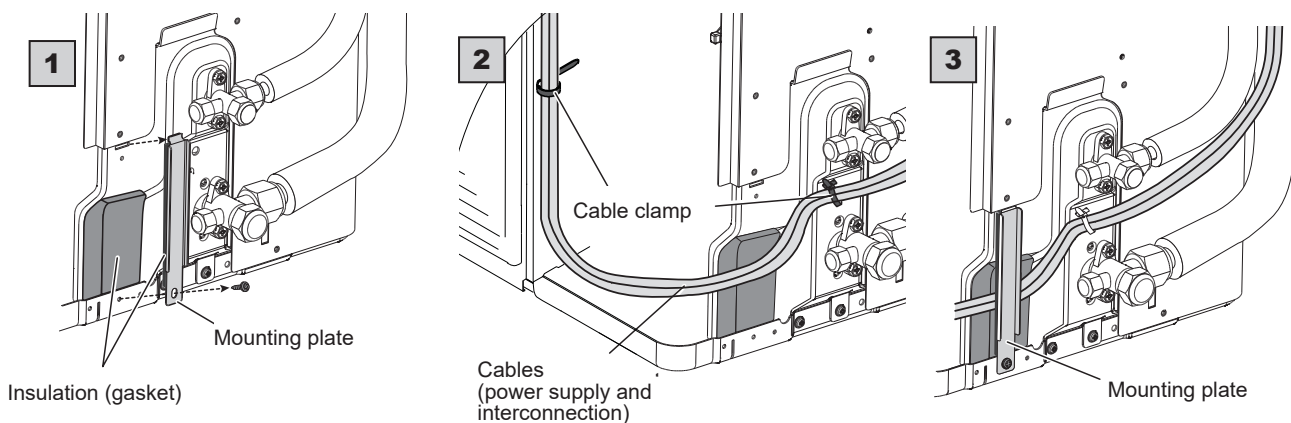

fig. 32 - Finalising connection of single phase outdoor unit

► Electrical connections on the 3-phase outdoor unit side

Access to connection terminals:

- Remove the front plate. Remove the screws and front panel.
- Make the connections according to the diagram(s) fig. 37, page 39.

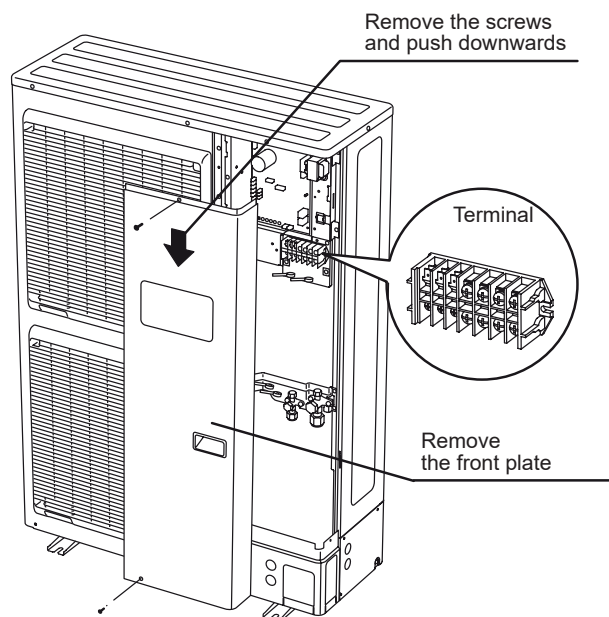

fig. 33 - Access to 3-phase outdoor unit's terminal block

- Use cable clamps to prevent any power cables from being disconnected accidentally.
- Fill in the space where the cables enter the outdoor unit with the insulating plate.

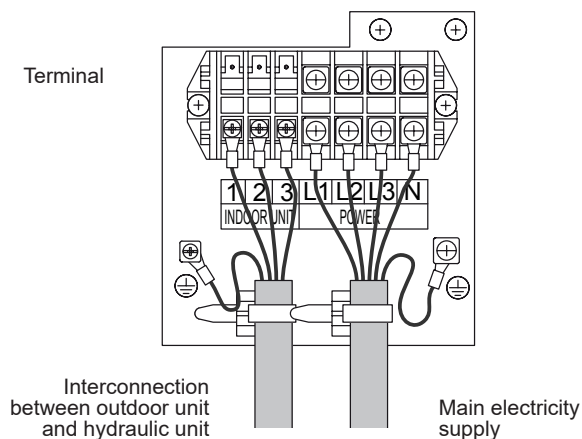

fig. 34 - Access to 3-phase outdoor unit's terminal block

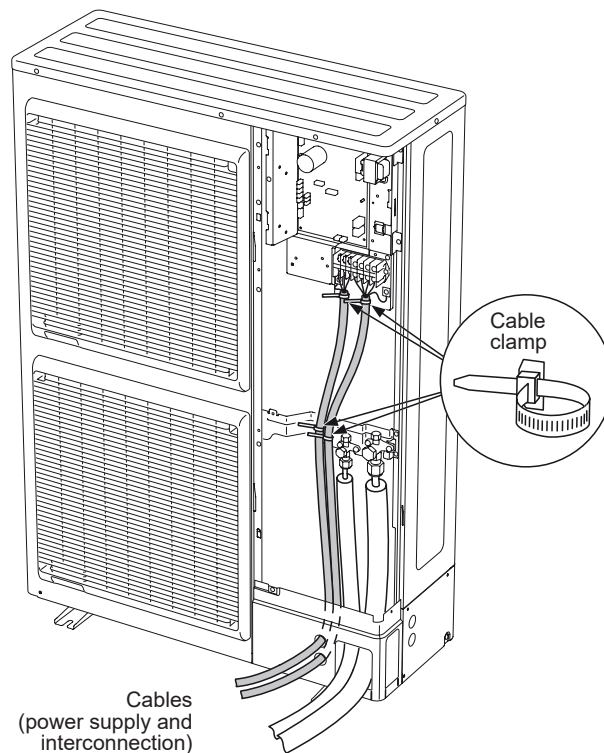

fig. 35 - Finalising connection of 3-phase outdoor unit

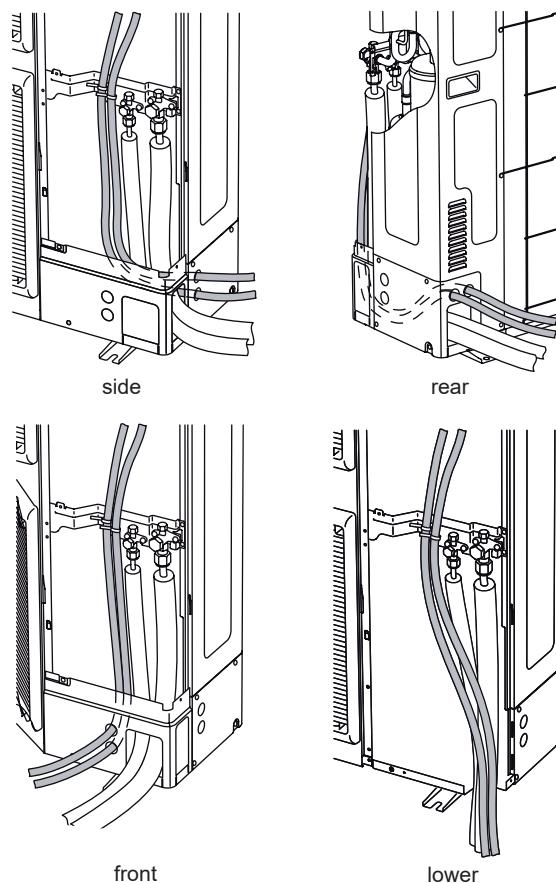

fig. 36 - Feeding cables and refrigeration connections from the 3-phase outdoor unit

► Electrical connections on the hydraulic unit side

Access to connection terminals:

- Remove the front panel (2 screws).
- Open the power control box.
- Make the connections according to the diagram (fig. 37).

Do not place the sensor and power supply lines parallel to each other to avoid interference due to voltage spikes in the power supply.

Make sure that all electrical cables are housed in the areas provided for this purpose.

▼ Interconnection between outdoor unit and hydraulic unit

Match up the terminal block markers on the hydraulic unit to those of the outdoor unit exactly when connecting the interconnection cables.

An incorrect connection could result in the destruction of one or other of the units.

▼ Electrical backups

If the heat pump is not installed with a boiler connection:

- Connect the power supply for the backup to the electrical panel.

▼ Second heating circuit (option)

- Refer to the instructions supplied with the double hydraulic circuit kit.

▼ DHW tank with electrical backup heating

The system is designed to be fitted with a DHW Heat Pump cylinder. The packaged cylinder comes supplied with electrical backup heating for DHW (fig. 39).

- Please also refer to the instructions supplied with the cylinder.

▼ Contract with Energy Supplier

The heat pump can be set to operate within particular types of energy contract, e.g. off-peak, day/night. In particular, domestic hot water (DHW) at the comfort temperature will be produced at off-peak times when electricity is at its cheapest.

- Connect the "Power Provider" contact to input EX2.
- Set the DHW configuration to "Off-Peak".
- 230V on input EX2 = "Peak Hours" information activated.

▼ Power limitation or EDR (Energy Demand Reduction)

Power limitation is designed to reduce electricity consumption when it is too high for the contract signed with the energy supplier.

- Connect the power limiter device to input EX1. Heat pump and DHW backups will be shut off in the event of over-consumption by the dwelling.
- 230 V on input EX1 = power limitation in progress.

▼ Faults external to the heat pump

Any component which reports back information (Underfloor heating safety switch, thermostat, pressure switch, etc.) may signal an external problem and stop the heat pump.

- Connect the external component (contact normally open) in parallel of junction box contact on EX3
- 230 V on input EX3 = heat pump stopped (system displays Error 369).

Single phase model

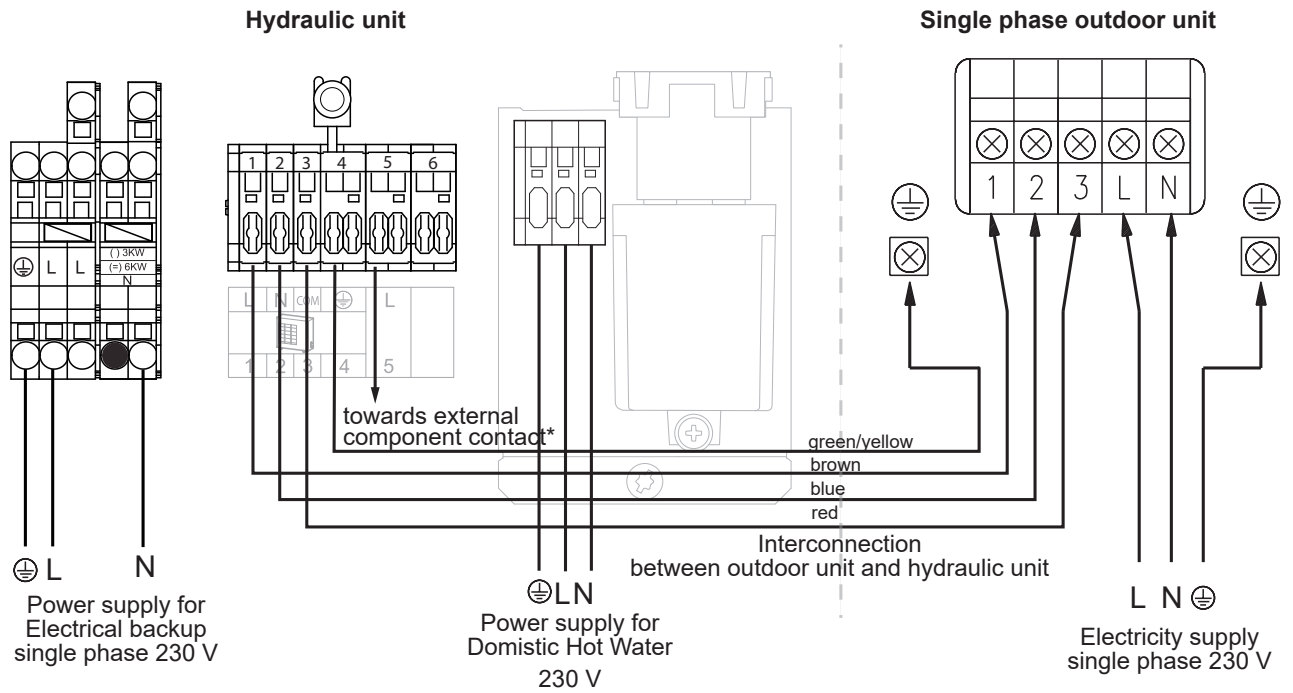

3-phase model

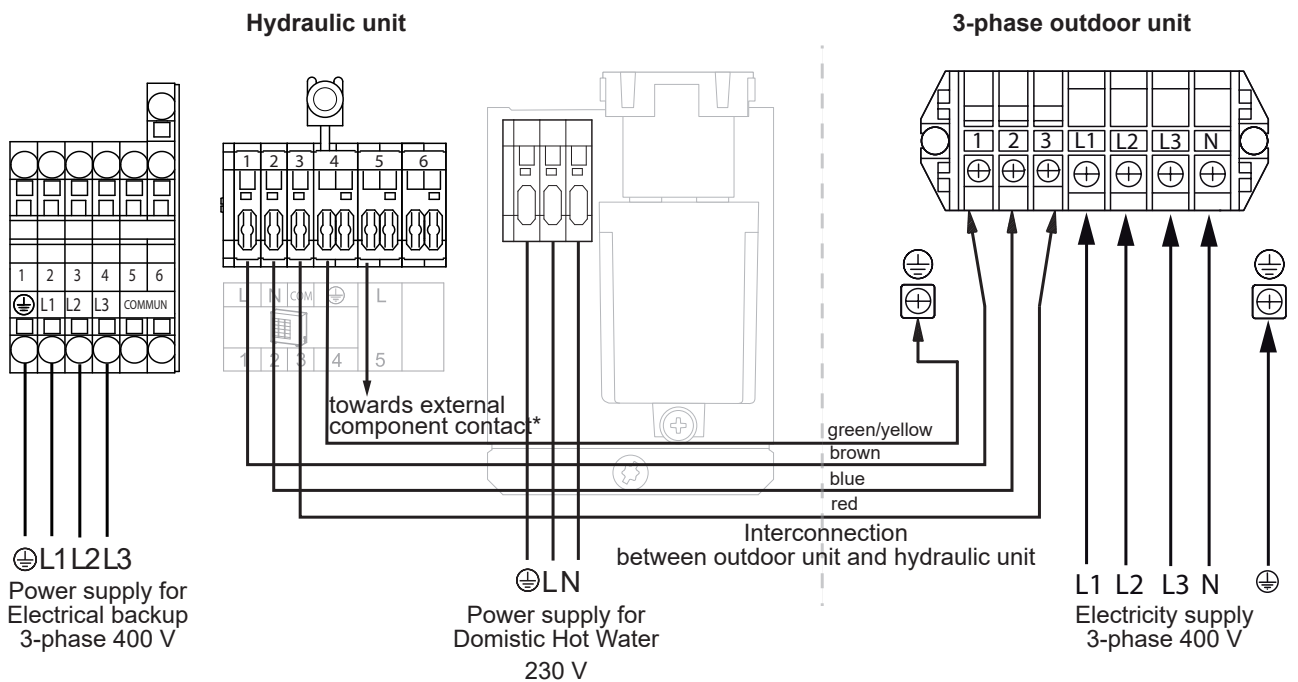
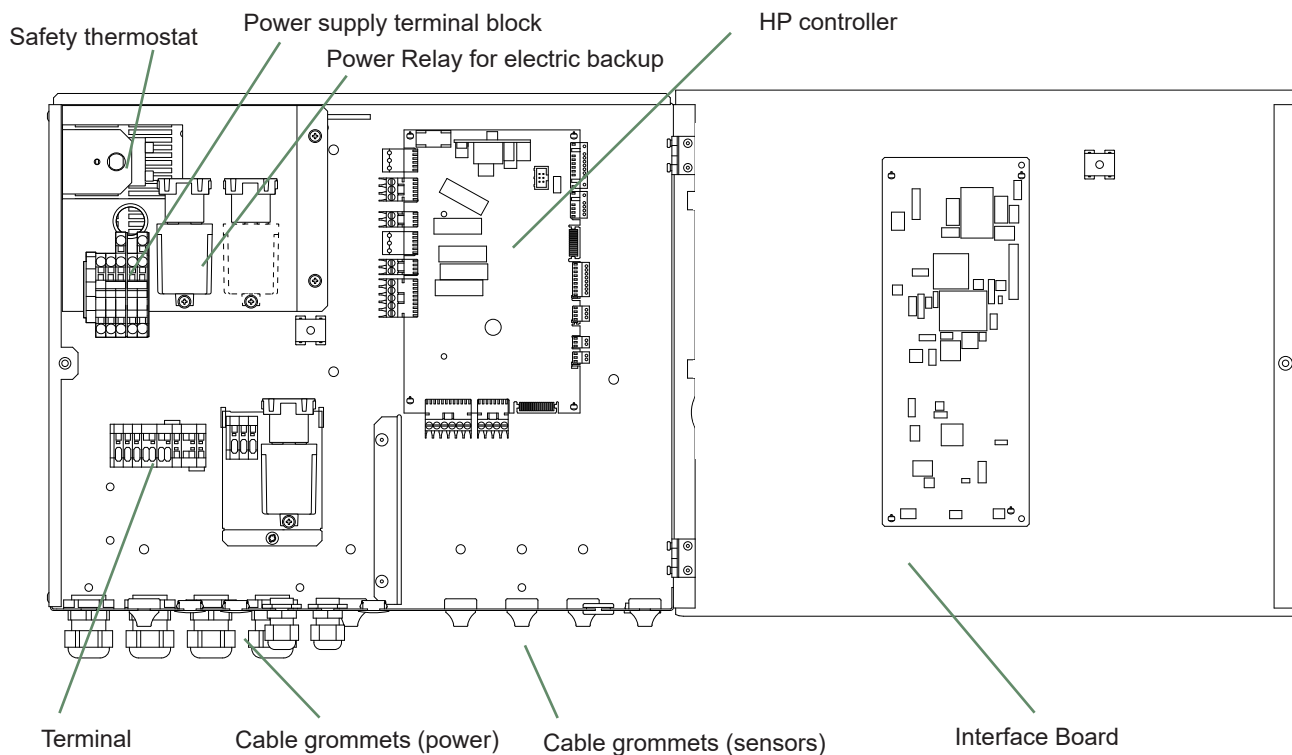

fig. 37 - Connection to terminal blocks and power relay

Single phase model



3-phase model

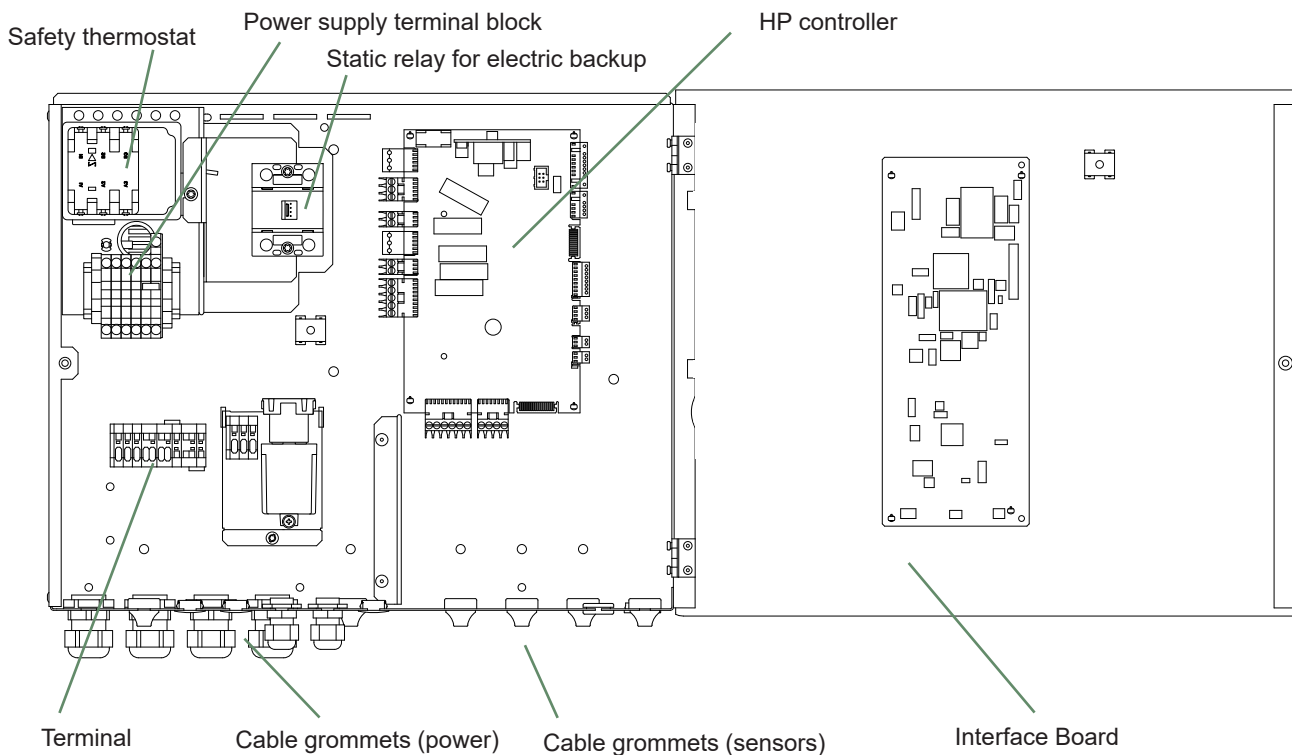
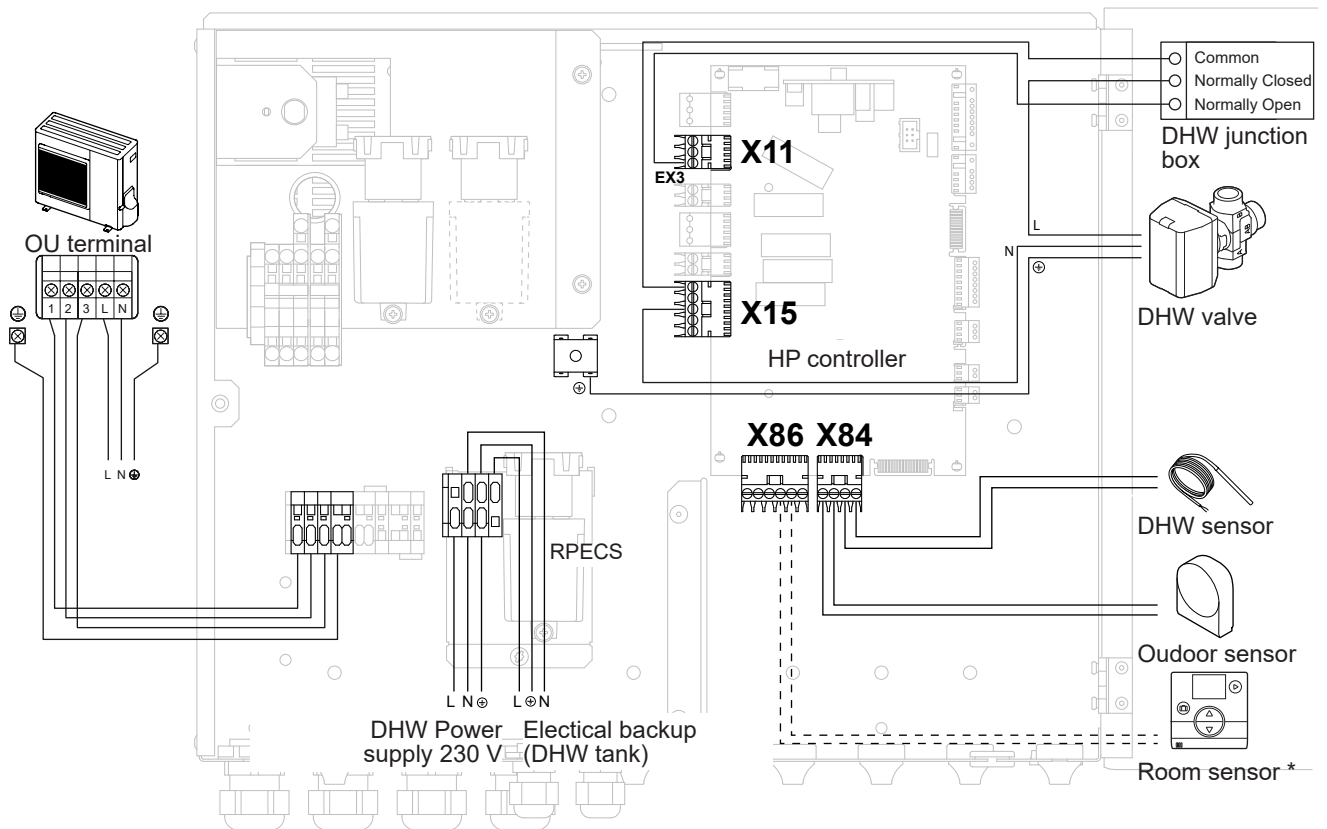

fig. 38 - Description of the hydraulic unit's electrical control box



* Room sensor can be powered by batteries or mains wired.

fig. 39 - DHW electrical connections

► Outside sensor

The outside sensor is required for correct operation of the heat pump.

Please see the fitting instructions on the sensor's packaging.

Place the sensor on the coldest side of the building, generally the northern or north-western side.

It must not be exposed to morning sun.

It must be installed so as to be easily accessible but at least 2.5m from the ground.

It is essential that it is not placed near any sources of heat such as flues, upper parts of doors and windows, near extractor vents, under balconies and eaves, or anywhere which would insulate the sensor from variations in the outdoor air temperature.

- Connect the outside sensor to connector **X84** (terminals **M** and **B9**) on the heat pump control board.

► Room sensor (option)

The room sensor (room unit) is optional.

Please see the fitting instructions on the sensor's packaging.

The sensor must be installed in the living room area on an unobstructed wall. It must be installed so as to be easily accessible.

Avoid direct sources of heat (chimney, television, cooking surfaces, sun) and draughty areas (ventilation, door, etc.).

Draughts in buildings are often brought about by cold air blowing through the electrical ducting. Lag the electrical ducts if there is a cold draught behind the room sensor.

▼ Installing a room sensor

• Room sensor A59 (if cabled)

- Connect the sensor's power supply to connector **X86** on the HP control board using the connector provided (terminals **2** and **3**).

• Room sensor A75

- Connect the sensor's power supply to connector **X86** on the HP control board using the connector provided (terminals **2** and **3**).

▼ Installing a Typass ATL

- Connect the Typass ATL to connector **X86** on the HP control board using the connector provided (terminals **1**, **2** and **3**).

▼ Fan convector zone

If the installation is equipped with fan convectors or dynamic radiators, **do not use a room sensor**.

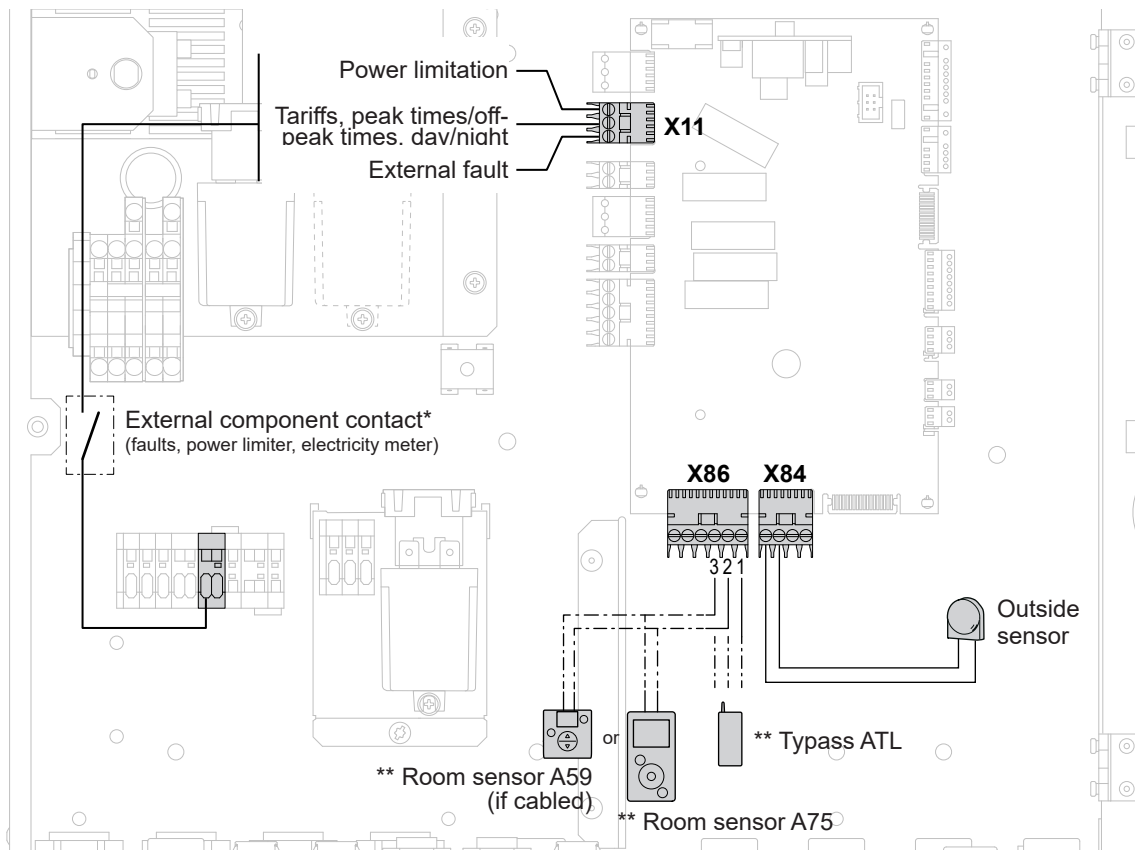

** If the control device does not provide a potential-free contact, the contact must be relayed to create an equivalent wiring. In any case, refer to the instructions for the external components (power limiting device, electricity meter, etc.) to create the wiring.

** Option

fig. 40 - Connections on the heat pump controller (accessories and options)

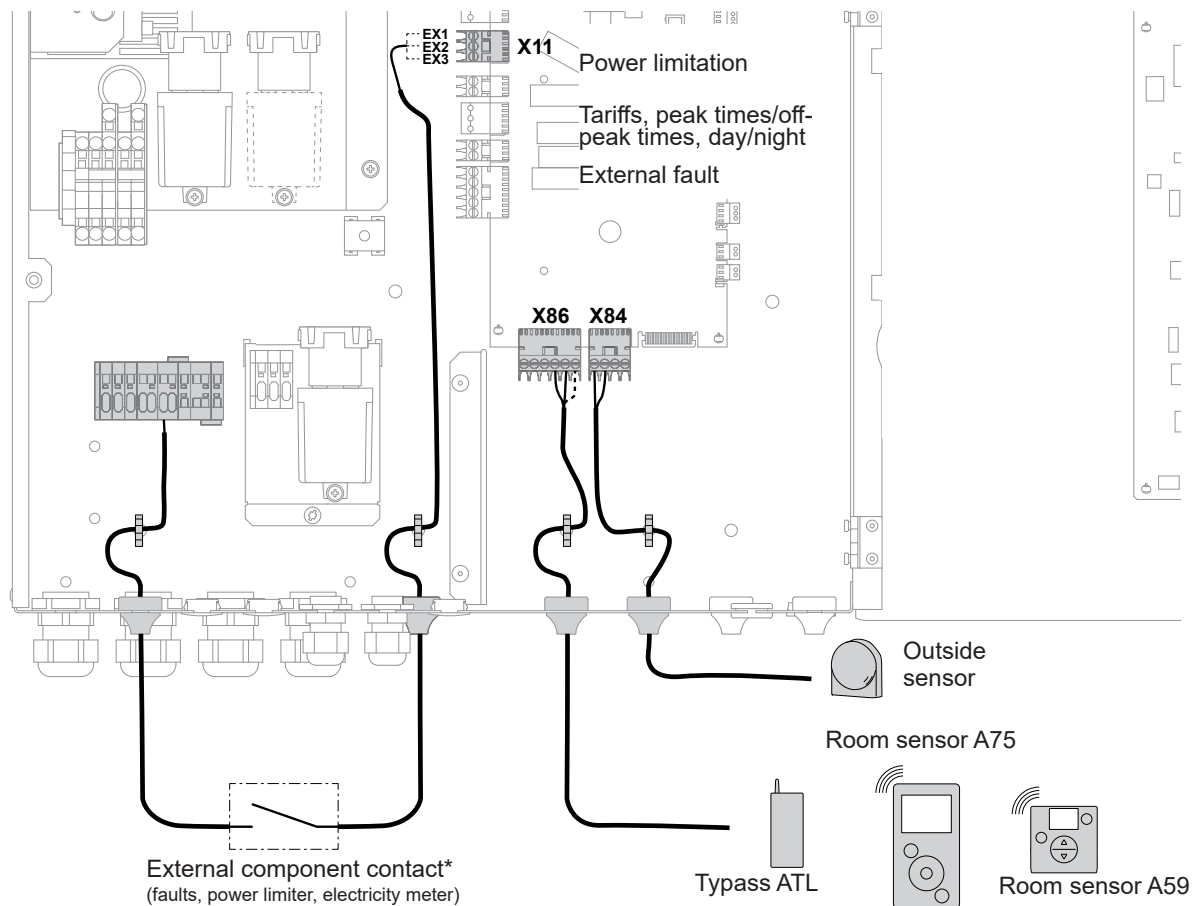

fig. 41 - Sensor cable feeds

Commissioning

- Close the installation's main circuit breaker.

Upon initial start-up (or in winter), to preheat the compressor, engage the installation's main circuit breaker (outdoor unit power supply) several hours before starting any tests.

- Press the heat pump's Start/Stop button.

To ensure that inputs EX1, EX2 and EX3 operate correctly: Check that the electricity supply's neutral phase polarity has been respected.

When the power is switched on and every time that the ON/OFF button is switched off and then switched on again, the outdoor unit will take approximately 4 minutes to start up, even if the setting is requesting heating.

When the power is switched on, the "Easy Start" quick start function allows you to set the appliance's initial settings.

- Turn the knob to choose the language.
- Press the knob to accept.

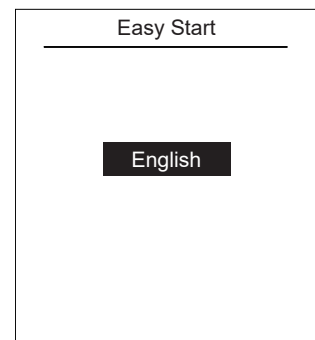

- Turn the knob to adjust the date. Press the knob to accept.
- Repeat this operation for the month, year, hours and minutes.

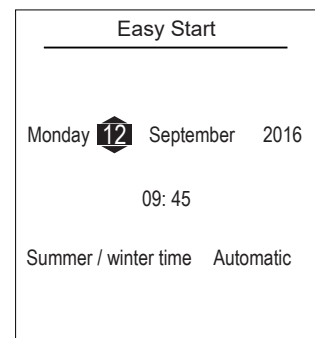

- Set the appliance's power.

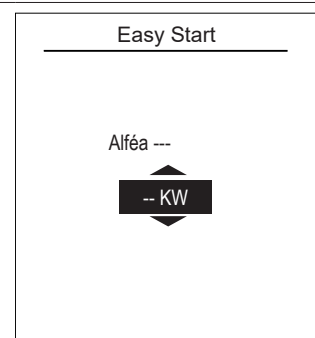

- Set the Electrical backup power:
3kW / 6kW / 9kW / None.

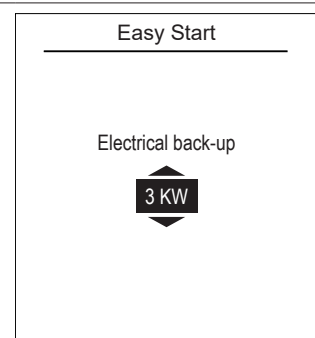

- If the installation covers 2 zones, set "2nd circuit kit" to "Yes".

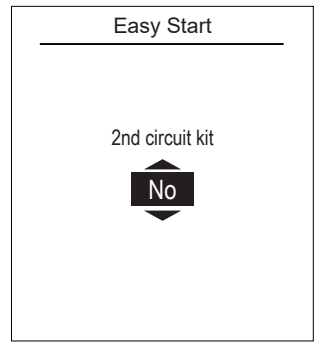

- Choose the radiator type for each zone:
Low temp. radiator / Heat. floor system / Dynamic Radiators / Radiators.

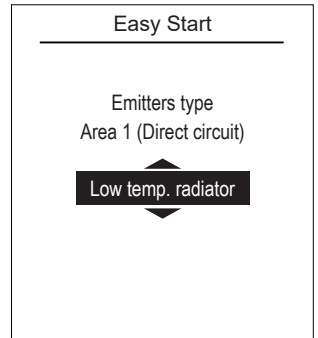

- If the installation is fitted with cooling function, choose the zone(s):
None / Area 1 / Area 2 / Area 1 and 2.

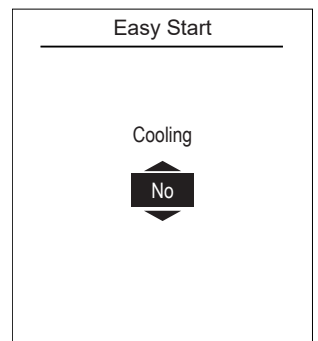

- Appliance settings summary screen. Press the knob to accept.
- The appliance starts initialising.

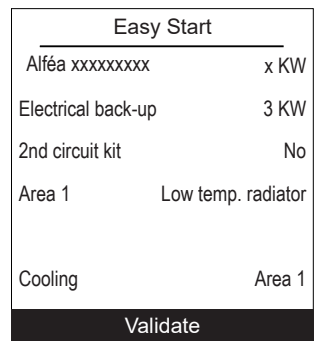

- The welcome screen is displayed (screen varies depending on installed options).

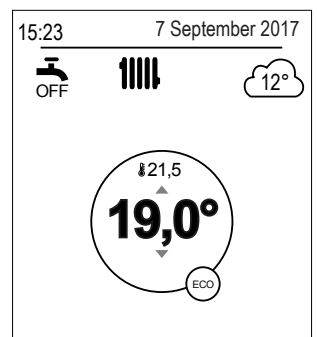

Upon commissioning, the electrical backup heaters is liable to start up even if the outdoor temperature at the time is above the heaters' trigger temperature.

The controller uses the initial average outdoor temperature of 0°C and needs time to update this temperature.

Controller Interface

► User Interface

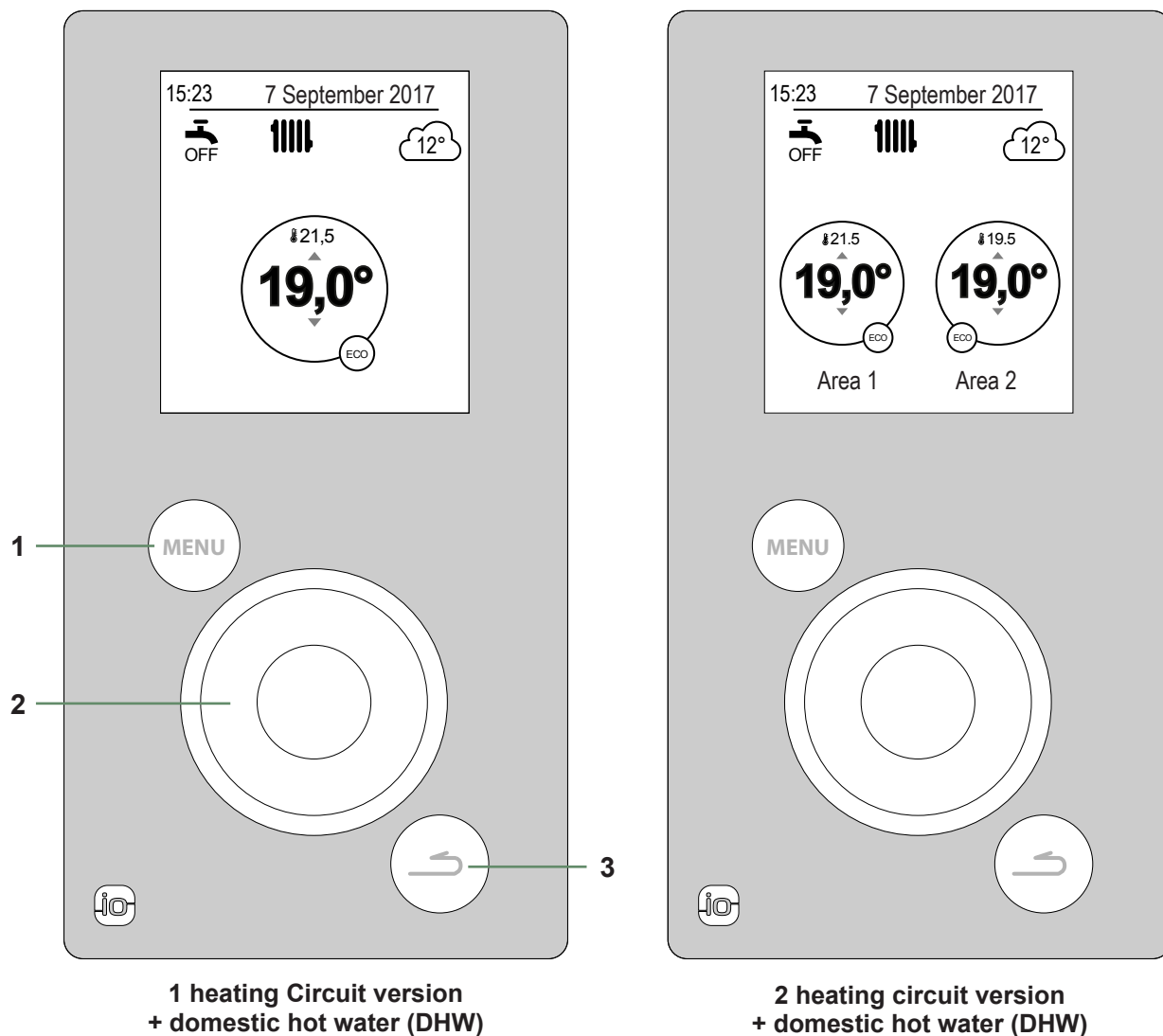

N°	Description
1	Menu button
2	Navigation knob (rotate knob), accept (press knob)
3	Back button

► Display Description

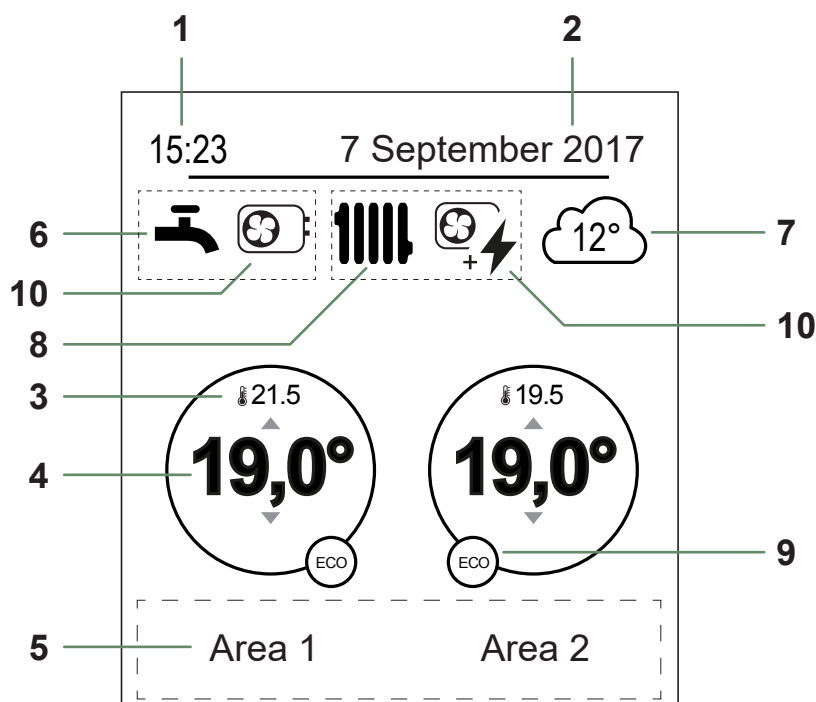

N°	Symbols	Definitions
1	15:23	Time
2	7 September 2017	Date
3	21.5	Temperature measured by the room sensor*
4	19,0°	Room temperature setpoint
5		Information (Area names, emergency mode, test mode, error display, etc.)
6	Domestic Hot Water (DHW)*:	
		Activated
		Boosting in progress
		Deactivated
7	12°	Temperature measured by the outside sensor
8	Operation	
		Heating
		Cooling*

N°	Symbols	Definitions
9	Mode	
		Comfort
		Manual (exemption)
	ECO	ECO
		Holiday
		Floor drying
		Stop (except frost)
10	Production via ...	
		Heat Pump
		Electrical backup
		HP + electrical backup

* Option

► Installer Menu

To access the Installer Menu, press and hold the  button and turn the knob a **quarter turn to the right**.
To return to the User Menu, repeat the same operation.

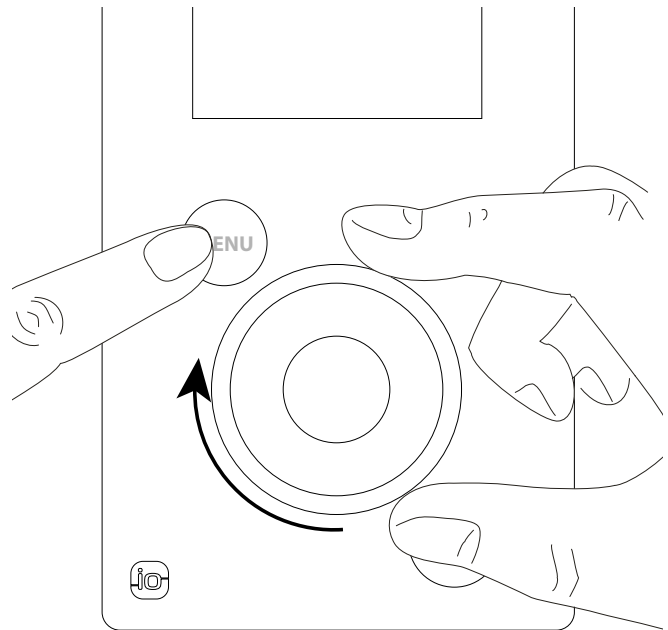







fig. 42 - Installer Menu

► Navigating the Menus

To ...	Action:
Access the menu	Press  .
Choose a menu item	Turn the knob to highlight your choice. Press the knob to accept.
Return to the previous menu	Press  .
Return to the main menu	Press  twice.
Return to the welcome screen	Press  or  on the main menu.

Note: Some settings (or menus) might not be displayed. They are dependent on the installation's configuration (and installed options).

► Modifying Settings

- Turn the knob to highlight the setting you wish to change.
- Press the knob to accept the change.
- Turn the knob to adjust the setting.
- Press the knob to accept your choice.

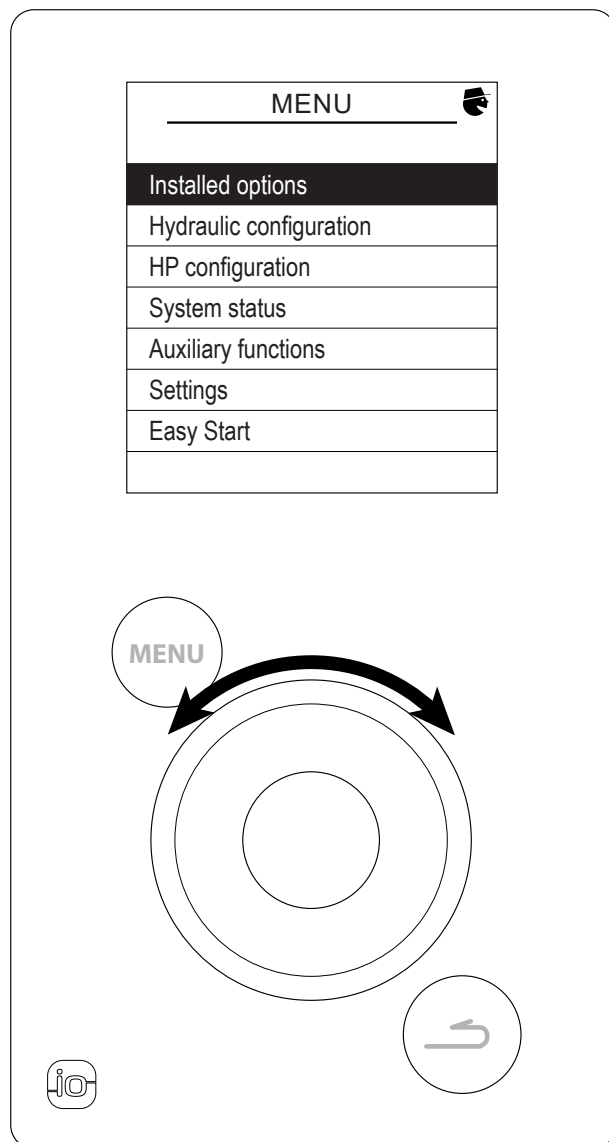

fig. 43 - Navigation

► Temperature control

The heat pump's operation is subject to the temperature control.

The heating circuit water temperature setpoint is adjusted according to the outdoor temperature.

If there are thermostatic valves on the installation, these must be fully open or set higher than the normal temperature setpoint.

▼ Setting

During the installation, the temperature control must be configured to suit the radiators and level of insulation of the dwelling.

The temperature control graphs (fig. 44) refer to a room temperature setpoint of 20°C.

The temperature control's gradient determines the impact of variations in the outdoor temperature on variations in the heating flow temperature.

The steeper the gradient, the more likely a slight reduction in the outdoor temperature will cause a significant increase in the water flow temperature in the heating circuit.

The temperature control off-set modifies the flow temperature of all graphs, without modifying the gradient (fig. 45).

Corrective actions to take in the case of discomfort are listed in the table (fig. 46).

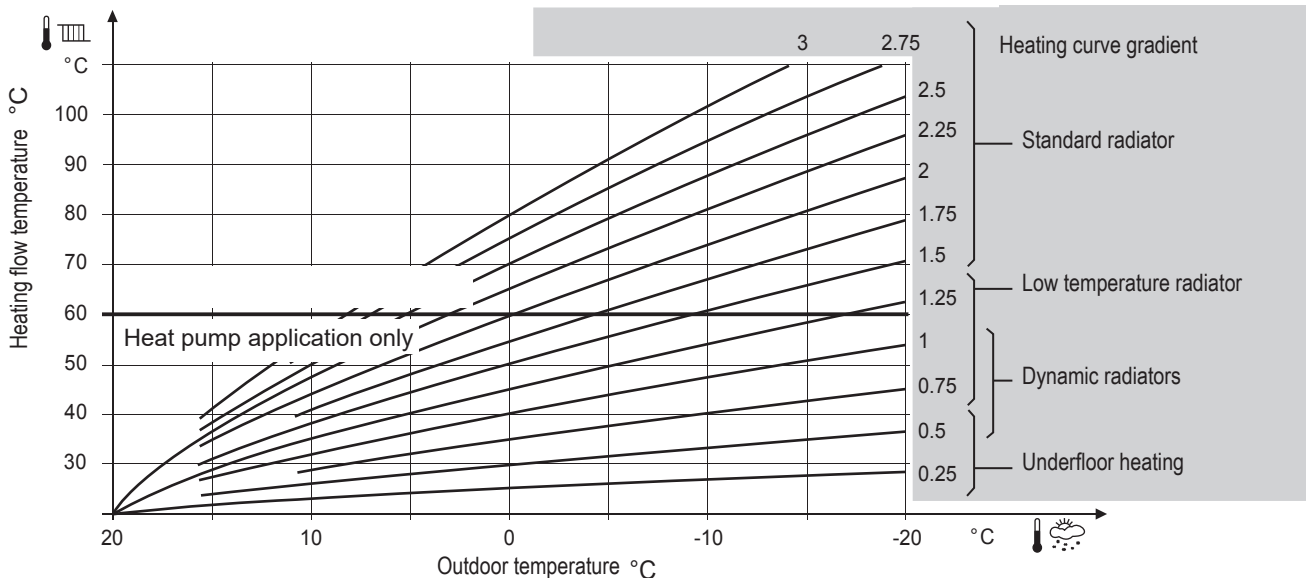

fig. 44 - Heating curve gradient

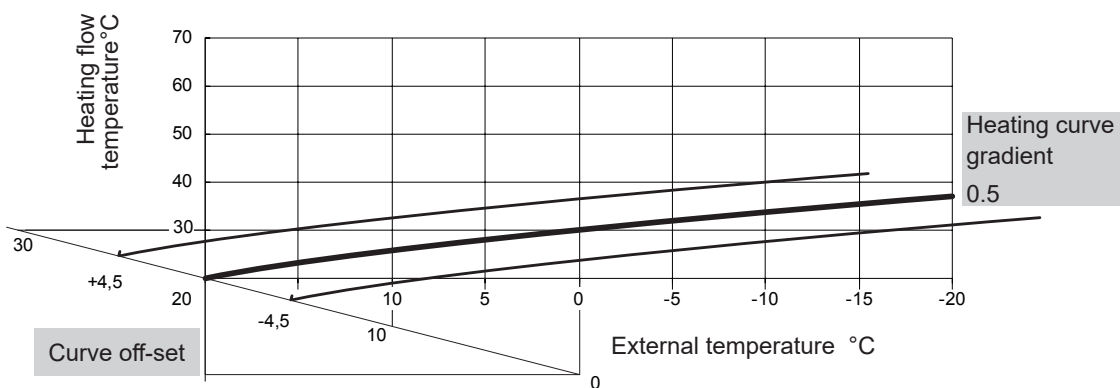

fig. 45 - Transferral of the heating curve

Sensations...		Corrective actions on the temperature control:	
...in mild weather	...in cold weather	Gradient	Off-set
Good	& Good	→ No correction	No correction
Cold	& Hot	→	
Cold	& Good	→	
Cold	& Cold	→ No correction	
Good	& Hot	→	No correction
Good	& Cold	→	No correction
Hot	& Hot	→ No correction	
Hot	& Good	→	
Hot	& Cold	→	

fig. 46 - Corrective actions in case of discomfort

Controller Menu

► Menu Structure

Installed options

page 52

Hydraulic configuration

page 53

Heating

Control / Temperature control

- Temperature control
- Comfort optimisation
- ECO mode limitation

- Setting setpoint T°
- Time programming

DHW

- General Configuration
- Time programming
- Setting setpoint T°
- Anti-legionella management

HP configuration

page 58

HP

- Compressor configuration
- Heating/cooling configuration
- DHW configuration
- Tariff input configuration
- Attenuation

Electrical backup / Connection boiler

System status

page 60

- Active functions
- Control panel
- Errors history
- Temperature control
- Energy consumption

Auxiliary functions

page 62

- Floor drying
- Relay test
- Outd. T° simulation
- Reset factory configuration

Settings

page 64

- Date and time
- Language
- Advanced/simplified menu
- Areas name
- Connectivities

- Connection
- Reset connectivities

Software version

Easy Start

page 68

Some settings (or menus) might not be displayed. They are dependent on the installation's configuration (and installed options).

Installed options

► Installed options

Installed options are configured during commissioning (see [page 44](#)). However, you can modify them by accessing the "Installed Options" menu.

Name of Appliance

- Choose the appliance's power.

Electrical backup

- Choose the electrical backup power.

Boiler connection

- The boiler connection is not available, setting remains set to "No" and should not be changed.

Number of Circuits

- Choose the number of circuits.

Cooling

- If the installation is fitted with cooling function, choose the zone(s):
None / Area 1 / Area 2 / Area 1 and 2.

Installed options	
Name of Appliance	-- KW
Electrical back-up	3 KW
Boiler connection	No
Number of circuits	2
Cooling	Area 1
Complete	

Hydraulic configuration > Area 1

► Hydraulic configuration

▼ Heating / Cooling

- Choose the heating zone to configure.

Hydraulic configuration
Area 1 (Direct circuit)
Area 2 (Mixed circuit)
Hot water

Some settings (or menus) might not be displayed. They are dependent on the installation's configuration (and installed options).

Choose the temperature control to adjust: "Heating".

Two methods for adjusting the temperature control are available: flow temperature or gradient control.

• Control using flow temperature

- ❶ - Set "Room T° influence" then select "Advanced settings".
- ❷ - Set "Display" to "flow T°". Set "flow T° to -10°C" and "flow T° to +20°C".
- ❸ - Set "Max flow T°" and "Min flow T°".

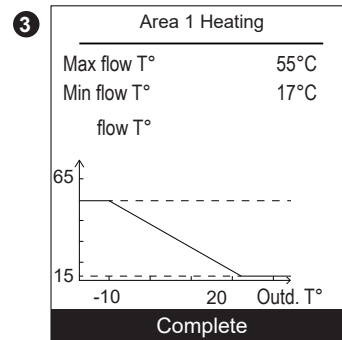
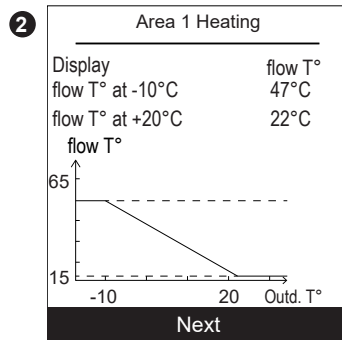
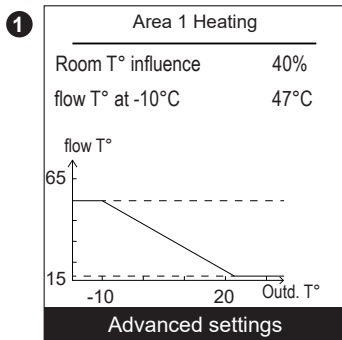

• Control using gradient

- ❶ - Set "Room T° influence" then select "Advanced settings".
- ❷ - Set "Display" to "Gradient". Set "Gradient" and "Off-set".
- ❸ - Set "Max flow T°" and "Min flow T°".

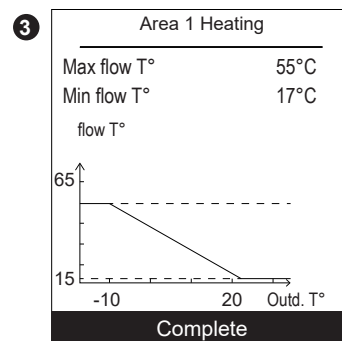
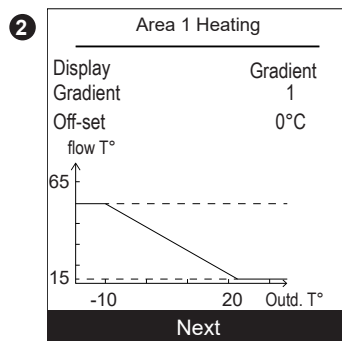
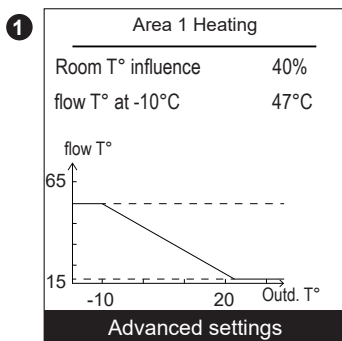

• Use 100% ambient temperature

If set to use 100%, adjust the radiator type.

Area 1 Heating	
Room T° influence	100%
Emitters type	Radiator
Max flow T°	55°C
Min flow T°	17°C

Some settings (or menus) might not be displayed. They are dependent on the installation's configuration (and installed options).

Comfort optimisation

"Accelerated decrease": ON / Stop.

"ECO / Comfort switchover" Anticipates time needed to reach the comfort setpoint.

"Comfort / ECO switchover" Anticipates time needed to switch from comfort setpoint to ECO setpoint.

Area 1	
Comfort optimisation	
Accelerated decrease	Stop
Max anticipation	
ECO / Comfort switchover	03:00 h
Comfort / ECO switchover	00:30 h

ECO mode limitation

"Activation outd. T°": Stopping outd. T°... +10°C.

"Stopping outd. T°": -30°C ... Activation outd. T°.

Area 1	
ECO mode limitation	
Activation outd. T°	---
Stopping outd. T°	-5°C

Setting setpoint T°

"Comfort T°": ECO Temperature ... 35°C.

"ECO T°": Absence Temperature ... Comfort Temperature.

"Absence T°": 4°C... ECO Temperature.

Heating temperatures factory settings:

Comfort 20°C, ECO 19°C, Absence 8°C.

Cooling temperatures factory settings:

Comfort 24°C, ECO 26°C, Absence 35°C.

Zone 1	
Heating Setpoint T°	
Comfort T°	20°C
ECO T°	19°C
Absence T°	8°C

1 - Choose "Heating" or "Cooling" as well as the appropriate zone by accessing the menu:
 "Programming" > "Heating" / "Cooling" > "Area 1" / "Area 2".

2 - Select the day.

3 - Adjust the Comfort period start and end times.

If 2 or 3 Comfort periods are not required, click on "--:--".

- To return to the previous setting (e.g. end 1st heating period to start of 1st heating period), press the  button.

• To copy the program to other days:

4 - Select "Validate and copy".

5 - Set the required days to "Yes" and then select "Complete".

• Else "Validate".

Heating / cooling period factory setting: 06:00 - 22:00.

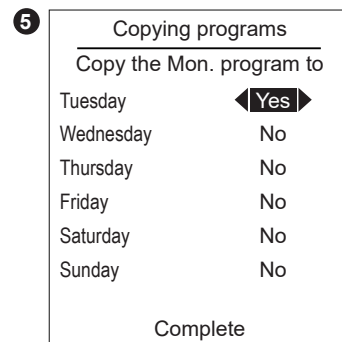
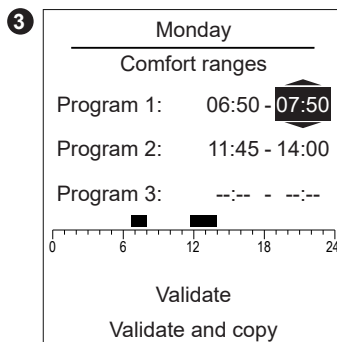
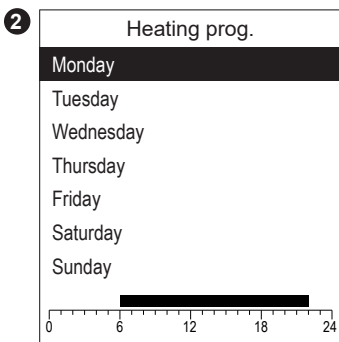

To delete a Comfort period, set its start and end times to the same value.
 When accepting a setting, the screen displays:

Program X: --:-- --:--

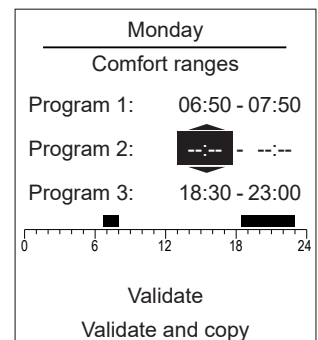

General Configuration

Hot Water (HW)

"Comfort T° charge": DHW program + off-peak hours / Off-peak hours / Permanent.
 Electrical back-up power: 0.1 to 10 KW.

DHW Circuit Configuration	
Comfort T° charge	
DHW program + off-peak hours	
Electrical back-up power	3KW

Time programming

Use the same procedure as the time program of heating periods. Resume from the step 2 (See "Time programming", page 56).

DHW period factory setting: 00:00 - 05:00, 14:30 - 17:00.

Setting setpoint T°

"Comfort T°": ECO Temp Setpoint ... 80°C.
 "ECO T°": 8°C... Comfort Temp setpoint.

DHW Circuit Setpoint settings	
Comfort T°	55°C
ECO T°	40°C

DHW temperature factory settings: Comfort 55°C, ECO 40°C.

Anti-legionella management

"Anti-legionella": Stop, ON.
 "Day of treatment": Monday / Tuesday / Wednesday / Thursday / Friday / Saturday / Sunday.
 "Hour of treatment": 00:00.
 "Setpoint T°": 55°C... 75°C.

DHW Circuit Anti-legionella management	
Anti-legionella	Stop
Day of treatment	Sunday
Hour of treatment	---
Setpoint T°	60°C

Some settings (or menus) might not be displayed. They are dependent on the installation's configuration (and installed options).

▶ Heat Pump Configuration

▼ Heat Pump

Compressor configuration

"Minimum shutdown time": 0 mins... 120 mins.
 "Max HP T°": 8°C... 100°C.
 "Post-circulation": 10 secs... 600 secs.
 "Power shedding operating": Automatic, When needed.

Released: HP = Start / DHW Backup = Stop / 1st HP Backup = Stop /
 2nd HP Backup = Stop / Boiler = Start.

When needed (Locked): HP = Stop / DHW Backup = Stop /
 1st HP Backup = Stop / 2nd HP Backup = Stop / Boiler = Start.

HP	
Compressor configuration	
Minimum shutdown time	8 mins
Max HP T°	75°C
Post-circulation	240s
Power shedding operating	Released

Heating/cooling configuration

- "Summer/winter switchover outd. T°" Zone 1: 8°C... 30°C.
 "Mini. cooling switchover outd. T°": 8°C... 35°C.
 "Mini. time prior to heat./cool.switchover": 8h... 100h.
- "Circuit 2 heating": 0°C... 20°C.
 - "Circuit 2 cooling": 0°C... 20°C.

1

HP	
Heating/cooling configuration	
Summer/winter switchover outd. T°	18°C
Mini. cooling switchover outd. T°	---
Mini. time prior to heat./cool.switchover	24h
Next	

2

HP	
Heating/cooling configuration	
Mixing valve compensation Area 2	
Area 2 heating	0°C
Area 2 cooling	0°C
Complete	

DHW configuration

"Maximum HP DHW T°": 0°C... 80°C.
 "Switching differential": 0°C... 20°C.
 "Heat./cool. alternating time": 10 mins... 600 mins.
 (with dynamic radiator, set to 40 mins).
 "Max charging time": 120mins... 180mins.

HP	
DHW configuration	
Maximum HP DHW T°	52°C
Switching differential	7°C
Heat./cool. alternating time	90 mins
Max charging time	120 mins

Some settings (or menus) might not be displayed. They are dependent on the installation's configuration (and installed options).

"Type of use": Power shedding + Off-peak hours / Smartgrid.

"EX1: function activation": 230V / 0V.

"EX2: function activation": 230V / 0V.

"EX3: function activation": 230V / 0V.

Heat Pump	
Tariff input configuration	
Type of use	Power shedding + Off-peak hours
EX1: function activation	230V
EX2: function activation	0V
EX3: function activation	230V

▼ Electrical back-up

"Authorisation if outd. T° <": ---, -15°C... 10°C.

"Switching setting": 0°Cmin... 500°Cmin.

Configuration	
Back-up	
Authorisation if outd. T° <	2°C
Switching setting	100°C min

Some settings (or menus) might not be displayed. They are dependent on the installation's configuration (and installed options).

► System status

Active functions

The "Active Functions" page tells you which services are operating and allows you to change their status.

- "Indoor comfort": Heating / Cooling / Stop.
- "Area 1" / "Area 2" / "Hot water" / "Emergency mode": ON / Stop.

If "Indoor Comfort" is set to "Stop", Area 1 and 2 cannot be modified.

"Emergency mode":

"Stop" : The HP is operating normally (with backup if necessary).

"Start" : The HP is using the backup heating or boiler connection.

- ➔ Use the "Start" setting only in emergency or test mode as your heating bill could be large.

Active functions	
Indoor comfort	Heating
Area 1	Start
Area 2	Start
Hot water	Start
Emergency mode	Stop

Control panel

The "Control Panel" allows you to see the status of the different functions and actuators.

- 1 - Press the knob to access the "Control Panel" second screen.
- 5 - Press the knob to return to the "System Status" menu.

1 Control panel

Generator	40%
Elec. backup	Stop
HP circulation pump	ON
Flow setpoint	26°C
Flow temp	60°C
Return T°	50°C
Outdoor T°	20°C
Mode	Heating

Next

2 Control panel

Area 1

Setpoint T°	20°C
Flow T° setpoint	26°C

Next

3 Control panel

Area 2

Setpoint T°	20°C
Flow T° setpoint	26°C
Flow temp	22°C
Circulation	ON
Valve	Opening

Next

4 Control panel

DHW

Setpoint T°	55°C
T°	52°C
Valve	Heating
Back-up	ON

Next

5 Control panel

Power shedding input	Inactive
Off-peak hours input	Active
External fault input	Inactive

Complete

Some settings (or menus) might not be displayed. They are dependent on the installation's configuration (and installed options).

10: Outside sensor, **32:** Flow sensor 2, **33:** Flow sensor HP, **44:** Return sensor HP, **50:** DHW sensor 1, **60:** Room sensor 1, **65:** Room sensor 2, **83:** BSB short-circuit, **127:** Legionella temp, **441:** BX31 no function, **442:** BX24 no function, **443:** BX33 no function, **444:** BX34 no function, **369:** External, **370:** Thermodynamic source, **516:** Heat pump missing.

For more info about errors § "Fault Diagnosis", page 76.

Errors history		
10/09/2016	Error	441
10/09/2016	Error	369
09/09/2016	Error	441
09/09/2016	Error	369
20/08/2016	Error	369
20/08/2016	Error	369
01/08/2016	Error	441
01/08/2016	Error	369
14/07/2016	Error	441
06/05/2016	Error	441

Temperature control

See "Temperature control", page 50.

Energy consumption

Consumption can be displayed per usage:

- Heating (Zones 1 and 2).
- Cooling.
- Domestic Hot Water (DHW).
- Total (Heating + Cooling + Hot Water).

This information is available for:

- the last 8 days: daily consumption (Tdy = Today, D-1 = yesterday, etc.).
- the last 12 months: monthly consumption (Initial letter of month. e.g. J = January, etc.).
- the last 10 years: annual consumption (last 2 digits. e.g. 16 = 2016).

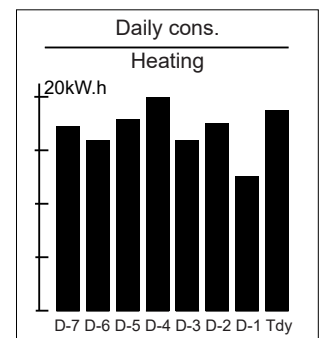

Example for daily consumption of the heating system.

► Auxiliary functions

Floor drying

- Choose the zone.
- Choose the "Drying type": *Stop / Automatic / Manual*.

• **Automatic Drying**

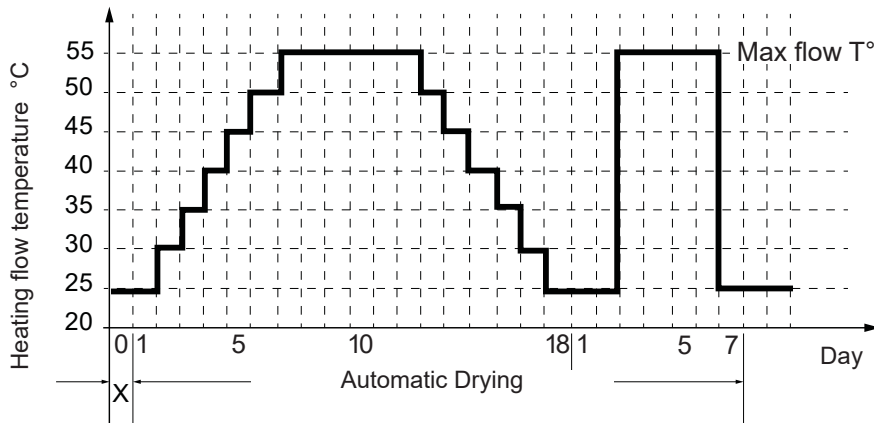

Area 1 floor drying	
Drying type	Stop
Flow T° setpoint	25°C

• **Manual Drying**

Manual mode enables you to programme your own concrete slab drying time. The function ends automatically after 25 days.

- Set the "Flow T° setpoint": 15°C... 60°C.

Please comply with the standards and instructions of the manufacturer of the building ! A good performance of this function is only possible with an installation correctly implemented (hydraulic, electricity and adjustments) ! This function can be stopped by anticipation when setting the adjustment to "Off".

Auxiliary functions

Relay test

- "HP circulation pump": ON / ----
- "Elec. backup 1": ON / ----
- "Area 2 circulation pump": ON / ----
- "Mixing valve": Open / Close / ----
- "DHW valve": DHW / ----
- "DHW backup": ON / ----
- "Boiler connection": ON / ----
- "Boiler connection ON / Stop": ON / ----



Don't forget to deactivate them after the tests.

Relay test	
HP circulation pump	----
Elec. backup 1	----
Area 2 circulation pump	----
Mixing valve	----
DHW valve	----
DHW backup	----

Outd. T° simulation

- "Simulated Outd. T°" : -50°C... 50°C.

Outd. T° simulation
Simulated Outd. T°

Reset factory configuration

The factory settings, stored within the controller, will replace and delete any custom programs.

Your custom settings will therefore be lost.

Reset factory configuration
Reset factory configuration

Some settings (or menus) might not be displayed. They are dependent on the installation's configuration (and installed options).

► Settings

Date and time

To set the appliance's date and time, access the menu:
"Settings" > "Date and Time".

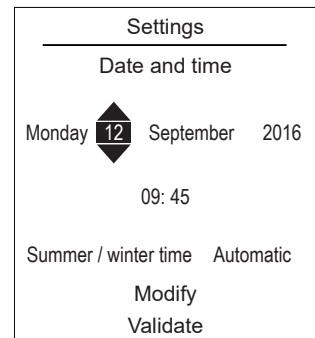

Language

To set the appliance's language, access the menu:
"Settings" > "Language".

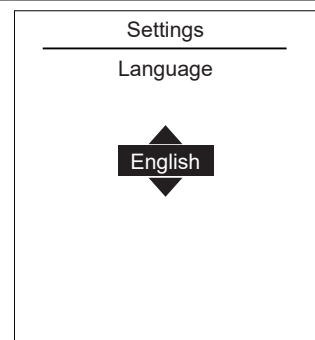

Two display modes for menus and appliance functions are available:

- **Advanced menu:**

- The appliance follows the time programming defined in paragraph "Time programming", page 56.

- **Simplified menu*:**

- The appliance operates at a constant temperature set directly by the user.
- Some functions are no longer accessible.

* The "Simplified Menu" setting is not compatible with the Cozytouch application.

Choose the display mode from the menu:

"Settings" > "Advanced/Simplified menu".

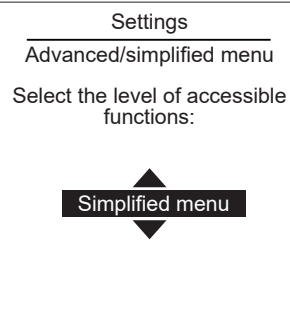

Setting the temperature in the Simplified Menu

1 zone

- 1- Turn the knob to adjust the temperature **directly**.

2 zones

- 2 - Select the zone. Accept.
- 4 - Set the temperature using the knob. Accept.

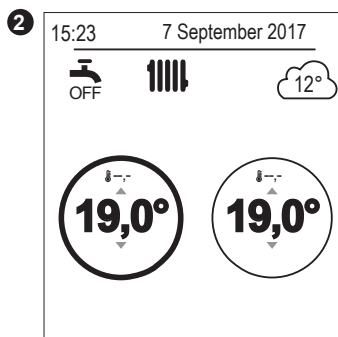
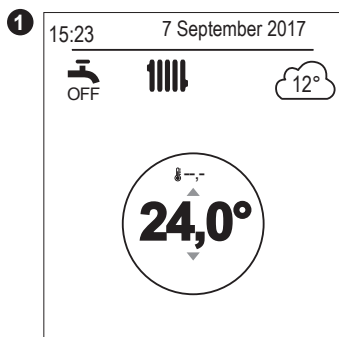

You can customise the zone names from the menu:

"Settings" > "Areas name".

Available names: *"Area 1" / "Area 2" / "Day area" / "Night area" / "1st floor" / "Lounge" / "G. floor" / "Bedroom" / "Floor" / "Radiator".*

Settings

Circuits name

Rename Zone 1 in

Day

Rename Zone 2 in

Night

To connect a room sensor, go to the menu:

"Settings" > "Connectivities" > "Connection".

The appliance waits for pairing for 10 minutes.

See the room sensor's installation instructions.

The "Connection" menu is no longer accessible if a sensor has already paired.

Settings

Connectivities

Connection



Quit

 All pairings are re-initialised annually.

Select "Re-set" in the menu:

"Settings" > "Connections" > "Re-set Connections".

Settings

Connections

Reset connectivities

Warning! The equipment will be removed from the system.

Quit

Reset

Show the display and controller software versions.

Software version

HMI:

xxxx xxxx xxxx xxxx

Controller:

RVS21 - 85.002.030

► Easy Start

- Turn the knob to choose the language.
- Press the knob to accept.

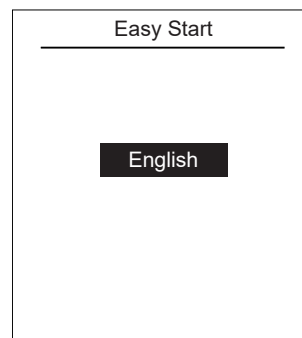

- Turn the knob to adjust the date. Press the knob to accept.
- Repeat this operation for the month, year, hours and minutes.

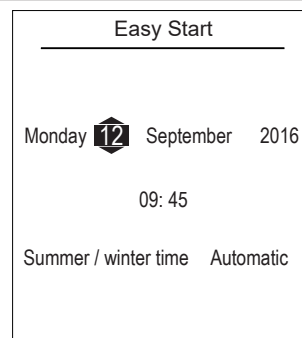

- Set the appliance's power.

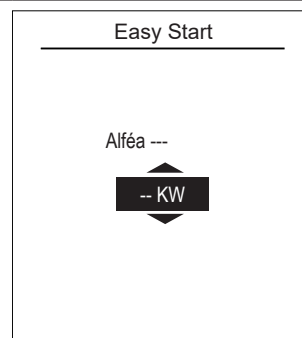

- Set the Electrical backup power:
3kW / 6kW / 9kW / None.

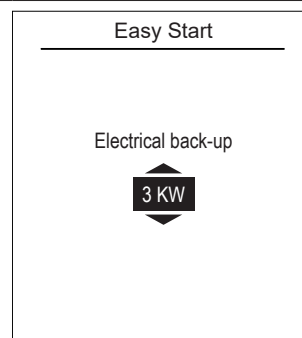

- If the installation covers 2 zones, set "2nd circuit kit" to "Yes".

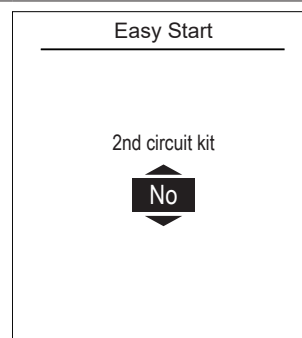

Some settings (or menus) might not be displayed. They are dependent on the installation's configuration (and installed options).

- Choose the radiator type for each zone:

Low temp. radiator / Heat. floor system / Dynamic Radiators / Radiators.

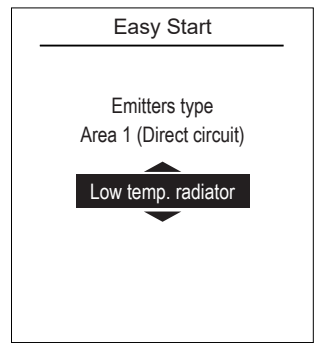

- If the installation is fitted with cooling function, choose the zone(s):

None / Area 1 / Area 2 / Area 1 and 2.

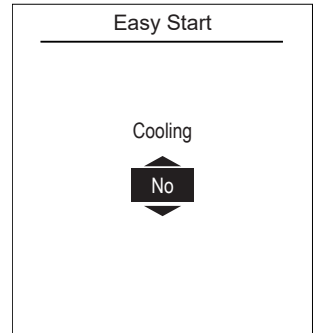

- Appliance settings summary screen. Press the knob to accept.

- The appliance starts initialising.

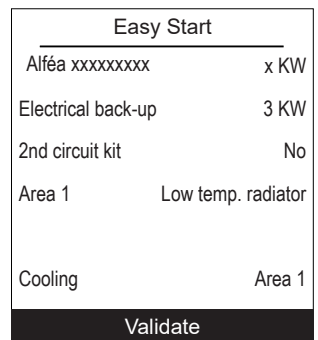

- The welcome screen is displayed (screen varies depending on installed options).

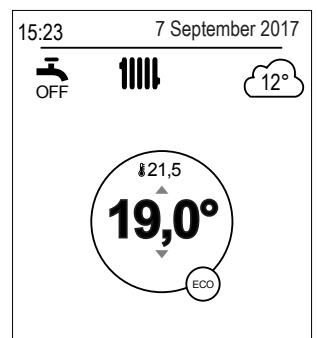

Upon commissioning, the electrical backup heaters or boiler are liable to start up even if the outdoor temperature at the time is above the heaters' trigger temperature.

The controller uses the initial average outdoor temperature of 0°C and needs time to update this temperature.

Some settings (or menus) might not be displayed. They are dependent on the installation's configuration (and installed options).

Basic Hydraulic Layout

■ Configuration 1: 1 heating circuit

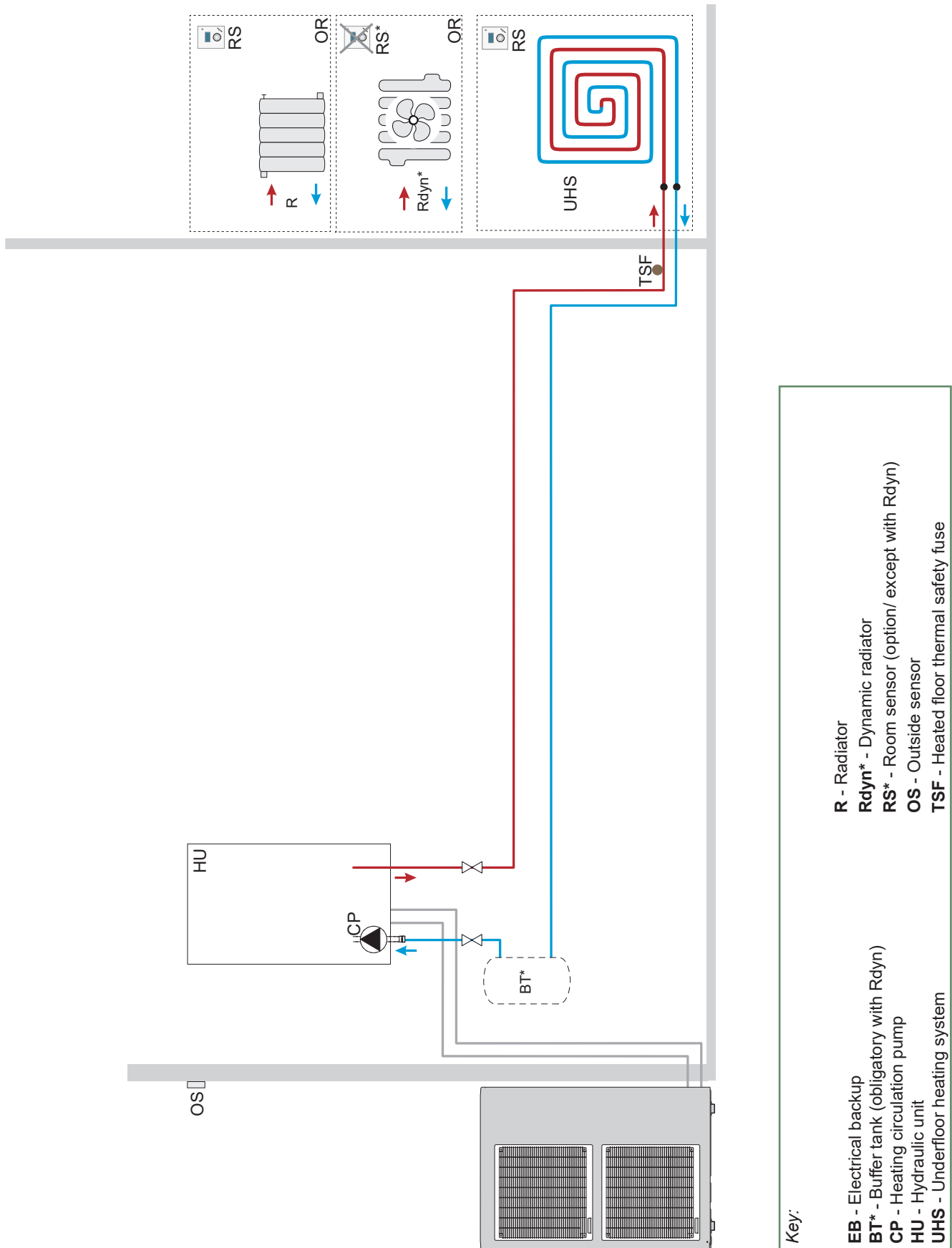

■ Configuration 1: 1 heating circuit and mixed hot water tank

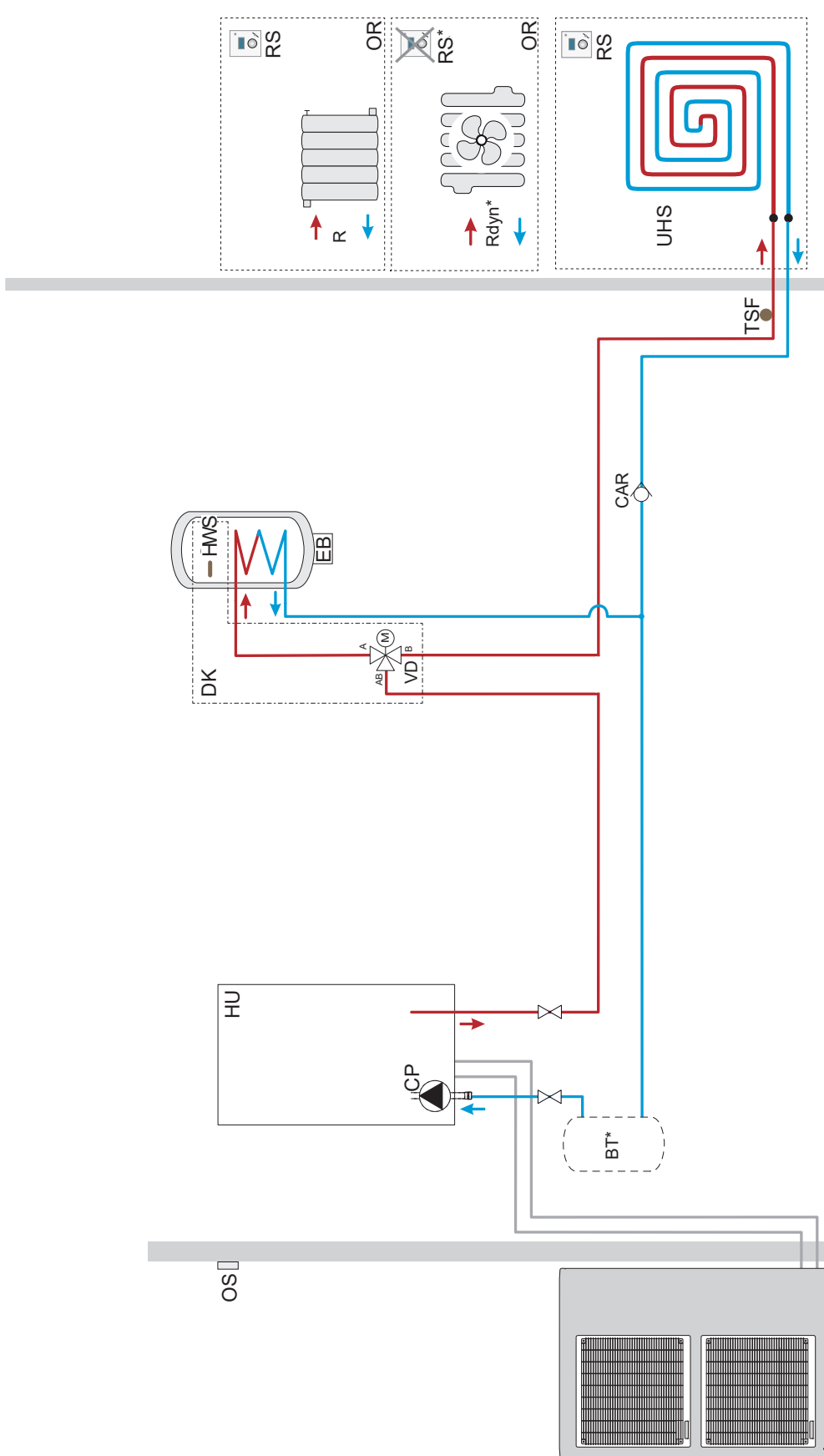

Key:

EB - Electrical backup	R - Radiator
BT* - Buffer tank (obligatory with Rdyn, if HP>11kW)	Rdyn* - Dynamic radiator
CP - Heating circulation pump	RS* - Room sensor (option/ except with Rdyn)
DK - DHW kit	HWS - Hot water sensor
HU - Hydraulic unit	OS - Outside sensor
UHS - Underfloor heating system	TSF - Heated floor thermal safety fuse
	VD - Distribution valve

Electrical Cabling Plans

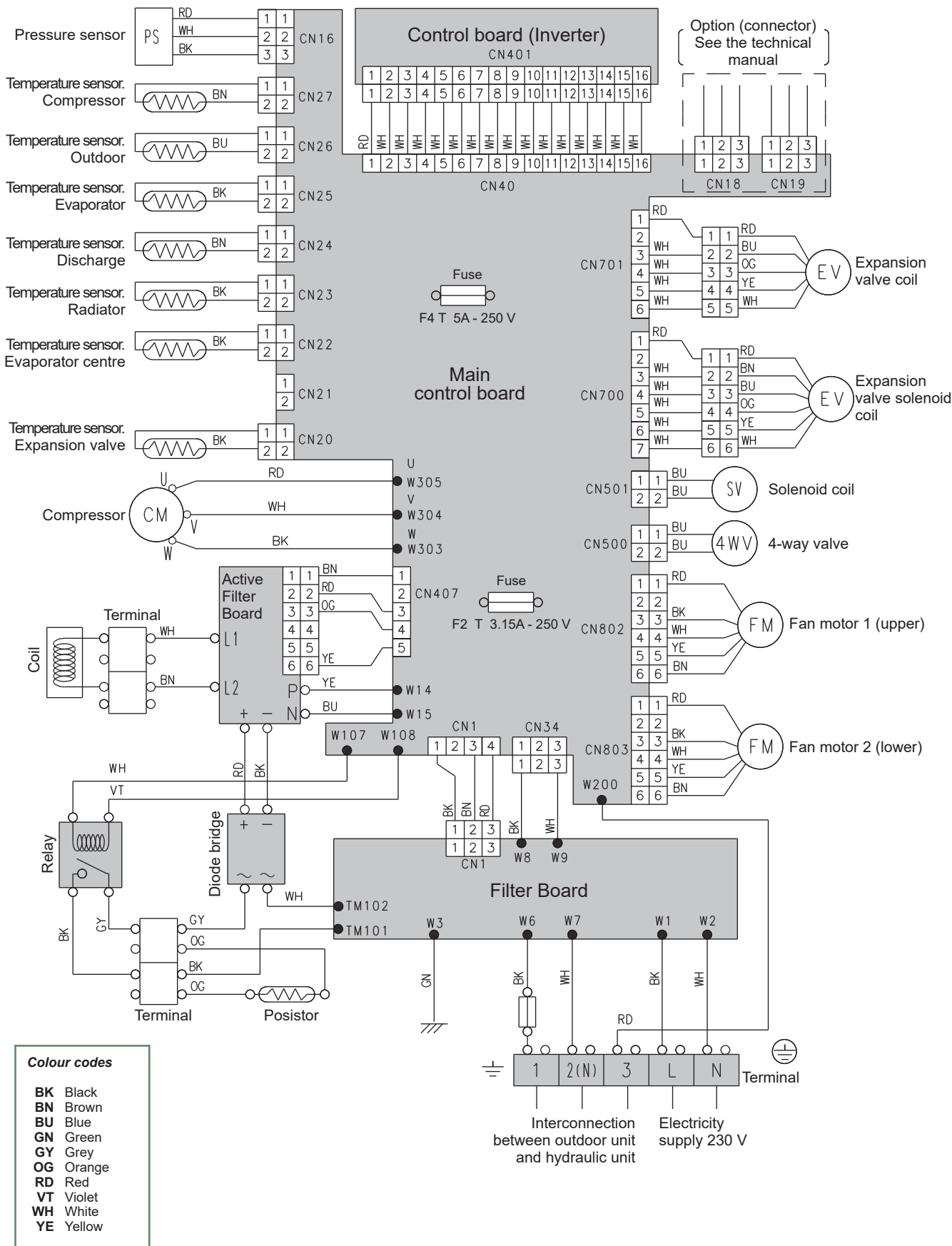

fig. 47 - Outdoor unit electrical cabling single phase Alféa Excellia A.I.

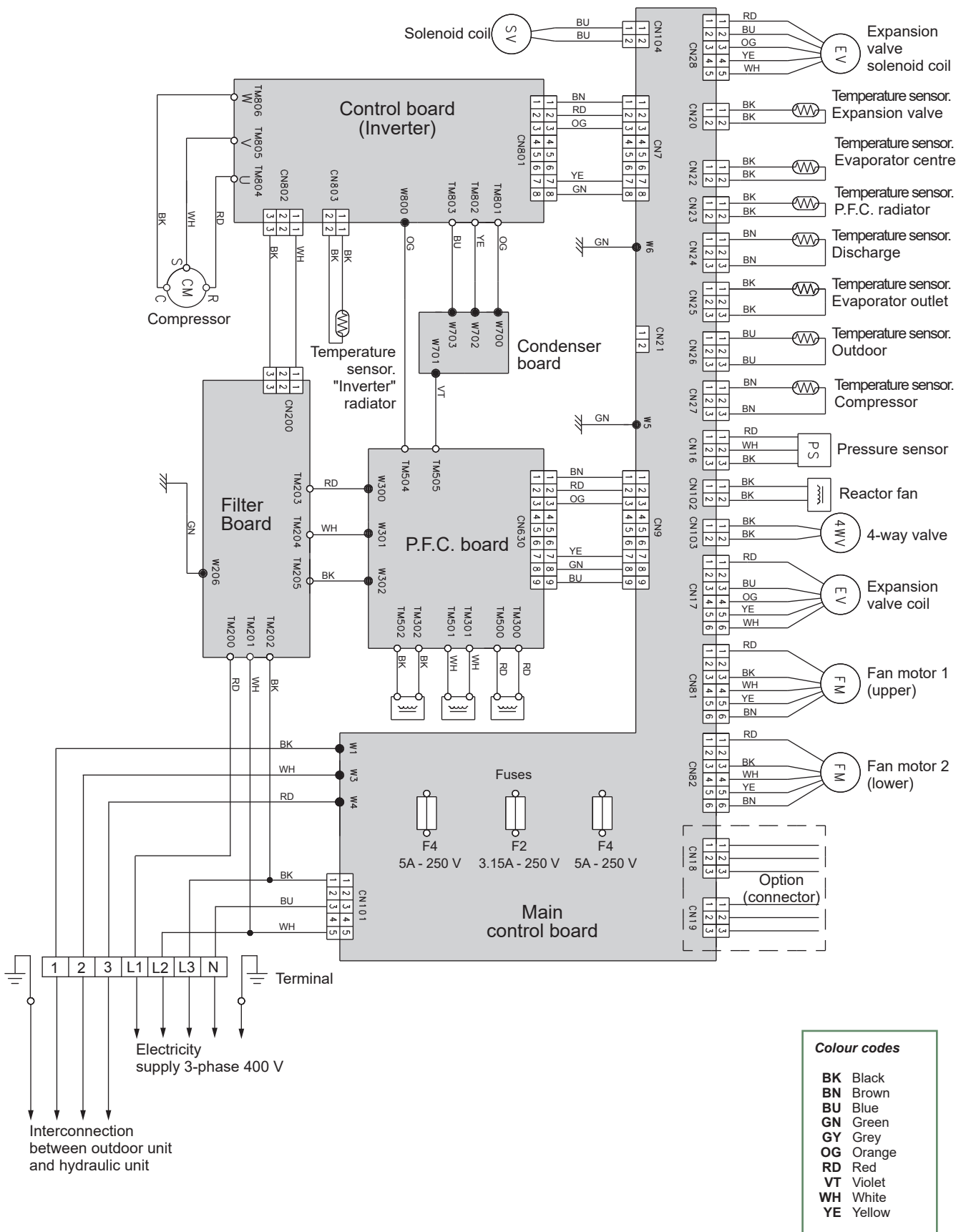

fig. 48 - Outdoor unit electrical cabling 3-phase Alfaea Excellia A.I.

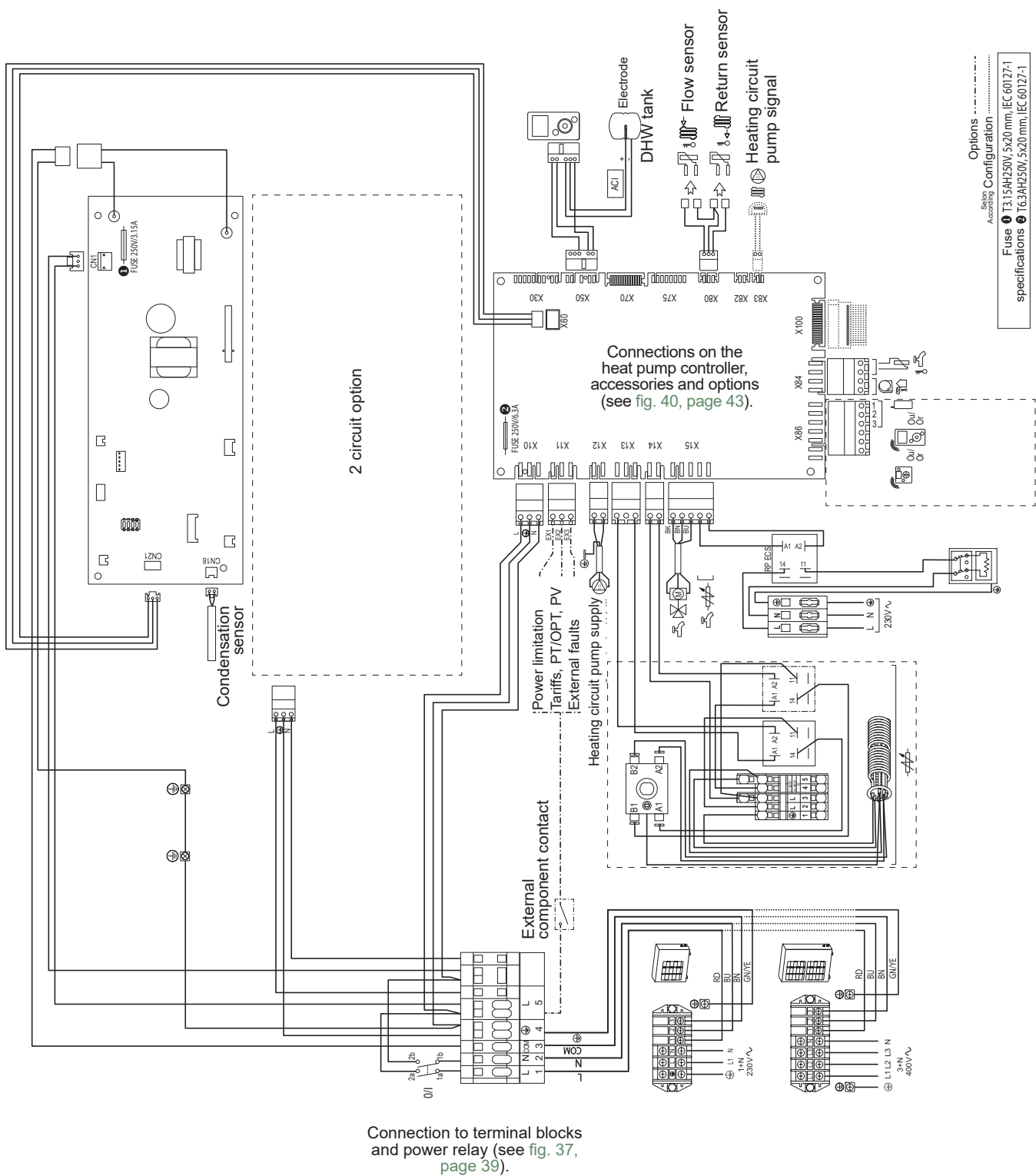

fig. 49 - Electrical cabling of single phase hydraulic unit Alféa Excellia (excluding connections made by installer)

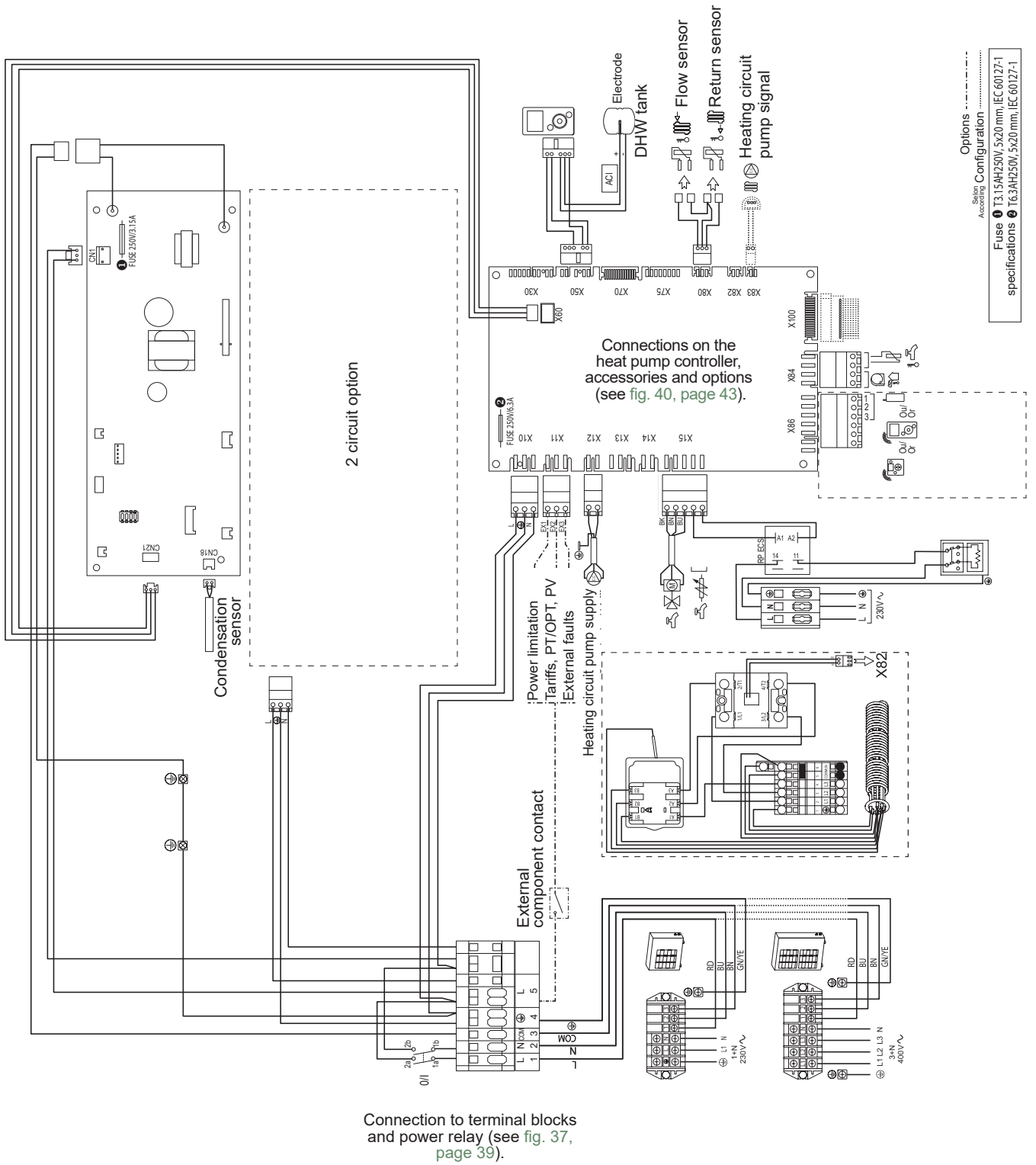
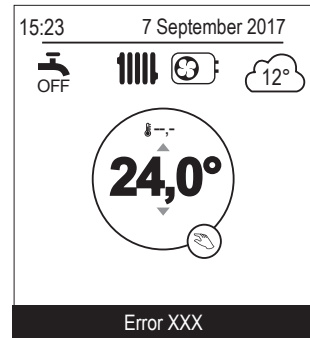

fig. 50 - Electrical cabling of 3-phase hydraulic unit Alféa Excellia (excluding connections made by installer)

Fault Diagnosis

If a fault occurs, the error number appears on the welcome screen.
To obtain the error's designation, select it using the knob.



In the event of an error originating in the outdoor unit, the user interface displays error code "370: Thermodynamic Generator" followed by the outdoor unit error.

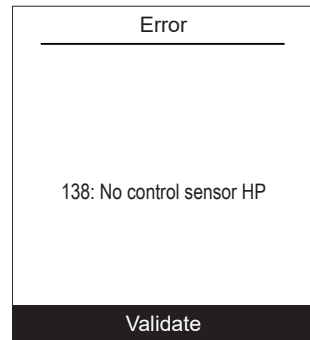

The error log can be viewed in the "System Status" > "Errors history", page 61.

► Faults in the Hydraulic Unit

Error	Designation	Probable causes	Proposed actions
10	Outside sensor	Short-circuit. Unplugged or disconnected sensor. Faulty sensor. Other fault.	- Check the sensor's wiring. - Replace the sensor.
32	Flow sensor 2		
33	Flow sensor HP		
44	Return sensor HP		
50	DHW sensor 1		
60	Room sensor 1		
65	Room sensor 2		
83	BSB, short circuit	Wiring problem (between the sensor or remote control, display and controller).	- Check the wiring.
127	Legionella temp	Anti-legionella temp setpoint not reached.	- Check the wiring of the DHW backup.
441	BX31 no function	Short-circuit. Unplugged or disconnected sensor. Faulty sensor. Other fault.	- Check the sensor's wiring. - Replace the sensor.
442	BX24 no function		
443	BX33 no function		
444	BX34 no function		
369	External	External safety triggered EX3.	-
370	Thermodynamic source	See details in "Faults in the Outdoor Unit".	-
516	Heat pump missing	Loss of connection between controller and HP.	- Check the wiring between X60 and the interface board.



**Before any maintenance operation, ensure that the general power supply is switched off.
Frost protection is not available when the heat pump is not powered up.**

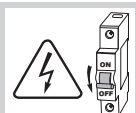

► Faults in the Outdoor Unit

Error	Interface Board		Outdoor Unit Board	Error designation
	LED Green	LED Red	LED	
11	1	1	Off	Serial communication error
			1	
32	3	2	-	UART communications error
42	4	2	22	Hydraulic unit heat-exchange thermistor error
63	6	3	18	Inverter error
64	6	4	19	Active filter error, PFC error
71	7	1	2	Discharge thermistor error
72	7	2	8	Compressor thermistor error
73	7	3	5	Heat-exchange thermistor error (centre)
			4	Heat-exchange thermistor error (outlet)
74	7	4	7	Outdoor thermistor error
77	7	7	9	Heat sink thermistor error (inverter)
			10	Heat sink thermistor error (P.F.C.)
78	7	8	6	Expansion valve thermistor error
84	8	4	-	Current sensor error
86	8	6	3	Pressure sensor error / Pressure switch error
94	9	4	13	Current tripped
95	9	5	15	Compressor motor control error
97	9	7	16	Outdoor unit fan motor error
			17	
A1	10	1	11	Discharge temperature 1 protection
A3	10	3	12	Compressor temperature protection
A5	10	5	20	Low pressure abnormal
-	-	-	-	Outdoor unit error

Maintenance of the installation



Before any maintenance operation, ensure that the general power supply is switched off.

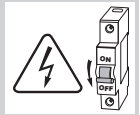

► Hydraulic checks



If frequent refills are required it is essential that you check for any leaks. When refilling, if a pressure reset is necessary, check what type of fluid was used initially.

Recommended filling pressure: between 1 and 2 bar (the exact filling pressure is determined by the water pressure in the installation).

Every year,

- Check the expansion circuit pressure (pre-inflation of 1 bar) and the correct operation of the safety valve.

If the installation is fitted with a hot water tank:

- Check the safety valve on the cold water supply inlet. Make it operate as advised by the manufacturer.
- Check the back flow preventer.

► Checking the outdoor unit

- Remove any dust from the exchanger, if deemed necessary make sure not to damage the blades.
- Straighten the blades using a comb.
- Check that there is nothing blocking the air flow.
- Check the fan.
- Verify that condensate drain is not obstructed.

• Checking the refrigeration circuit

If the amount of refrigerant in the system exceeds 2kg (models > 10kW), the refrigeration circuit must be checked annually by an approved engineer (they must have a certificate of competence for the handling of refrigerants).

- Check there are no leaks (connections, valves...).

► Electrical checks

- Check the connections and re-tighten if necessary.
- Check the state of the cables and plates.

Other maintenance

► Emptying the hydraulic unit

- Remove the front panel of the hydraulic unit.
- Open the drain plug,
- Check that the hydraulic unit's bleeder valve opens automatically,
- Open the installation's bleeder valve(s).

► Distribution valve

If the installation is fitted with a hot water tank. Ensure the distribution valve is fitted in the correct direction.

Channel **AB**: Outlet to the hydraulic unit.

Channel **A** open: Return from DHW tank.

Channel **B** open: Return from the heating circuit.

✔ Quick-start procedure

Before switching on the hydraulic unit:

- Check the electric wiring.
- Check the refrigeration circuit and make sure that it has been gassed.
- Check the hydraulic circuit's pressure (1 to 2 bar), check that the heat pump has been bled, along with the rest of the installation.
- Make sure that ALL DIP SW on the interface board are OFF before starting up.

▶ Start-up check-list

▼ Before starting-up

	OK	Not compliant
• Outdoor unit (see chapter "Installation of the outdoor unit", page 18).		
Location and fittings, condensate evacuation.		
Comply with distances from obstacles.		
• Hydraulic unit (see chapter "Installation of the hydraulic unit", page 20).		
Connection of pipes, valves and pumps (heating circuit, DHW).		
Installation water volume (expansion vessel of adequate capacity?).		
No leaks.		
Main system pressure and degassing.		
• Refrigeration connections (see chapters "Refrigeration connections and filling the installation with gas", page 22).		
Check the refrigeration circuits (sealing, no dust or humidity).		
Connections between units (pipe length, flare tightening torque...).		
Installation of HP pressure gauges and vacuum gauges on the gas line (large tube).		
Pump down mandatory.		
Nitrogen leak test (~ 10 bar).		
Opening of refrigeration valves to outdoor unit.		
Refrigerant filling for the hydraulic module and pipes.		
• Electrical checks Outdoor unit (see chapter "Electrical connections", page 34).		
Main power supply (230 V or 400 V).		
Protection by rated circuit breaker.		
Cable dimensions.		
Earth connection.		
• Electrical checks Hydraulic unit (see chapter "Electrical connections on the hydraulic unit side", page 38).		
Connection to outdoor unit (L, N, Earth or 3 L + Earth).		
Sensors connection (positioning and connections).		
Distribution valve connections (boiler and DHW) and circulation pump.		
Power supply and protection of electric backup.		

▼ Starting-up

	OK	Not compliant
• Quick Start Procedure (see chapter "⚙️ Commissioning", page 44 & "🏠 Controller Menu", page 52).		
Close the installation's main circuit breaker (outdoor unit power supply) <u>2 hours before testing</u> => Preheating of the compressor.		
Press the On/Off Switch => Initialisation takes several seconds.		
Operation of the heating circulation pump.		
Outdoor unit starts after 4 mins.		
Configure Time, Date and Heating circuit, DHW period programs if different from the default values.		
Configure the hydraulic circuit.		
Set the heating gradient.		
Adjust the max flow setpoint.		
• Outdoor unit checks		
Operation of fan(s), compressor.		
Current measurement.		
After several minutes measure the difference in air temperature.		
Check condensation and evaporation pressure/temperature.		
• Hydraulic unit checks		
After 15 mins of operation.		
Primary water temp. difference.		
Operation of heating, boiler backup, etc.		
• Temperature controller (see chapter "🏠 Controller Menu", page 52).		
Settings, maintenance, checks.		
Program the heating periods.		
Adjust the setpoints for the heating circuits if different from the default values.		
Setpoint display.		
Explanations of use.		

The heat pump is ready for operation!

► Commissioning technical datasheet

Site		Installer	
Outdoor unit	Serial N°.	Hydraulic unit	Serial N°.
	Model		Model
Refrigerant type		Refrigerant load kg	
Checks		Operating voltage & current on outdoor unit	
Compliance with positioning distances		L/N or L1/N	V
Condensate evacuation correct		L2/N	V
Electric connections / connections tightness		L3/N	V
No GAS leaks (unit ID N°.:)		L/T or L1/T	V
Installation refrigeration connection correct (length m)		L2/T	V
Taken in operation when HOT		L3/T	V
Compressor discharge temperature °C		N/E	V
Liquid line temp. °C		Icomp	A
Condensation temperature	HP = bar °C	Under-cooling °C	
Tank water output temperature	°C	ΔCondensation Temp. °C	
Tank water input temperature	°C	ΔSecondary Temp. °C	
Evaporation temperature	LP = bar °C		
Suction Temp.	°C	Overheating °C	
Battery air input temperature	°C	ΔEvaporation Temp. °C	
Battery air output temperature	°C	ΔBattery Temp. °C	
Hydraulic network on hydraulic unit			
Secondary system	Underfloor heating system	}	Circulation pump brand
	LT Radiators		
	Fan coils		
Domestic hot water; tank type		Type	
Estimated water volume of secondary system		L	
Options & accessories			
Power supply for electric backup		Room sensor A59	
Correct location of room sensor		Wireless room sensor A75	
2 circuit kit		Wireless room sensor A78	
DHW kit		Details	
Cooling kit			
Control settings			
Configuration type			
Essential settings			

Energy performance data is available in the user manuals.

Instructions for the end user



Explain to the user how his installation operates, in particular the functions of the room sensor and the programmes accessible to them via the user interface.

Emphasise that a heated floor has significant inertia and that therefore any adjustments must be made gradually.

Also explain to the end user how to check the filling of the heating circuit.



End-of-life of the appliance

The appliances must be dismantled and recycled by a specialised service. The appliances must not, under any circumstances, be thrown out with household waste, bulky waste or at a tip.

At the end of its service life, please contact your installer or local representative to proceed with its dismantling and recycling.



This appliance is marked with this symbol. It means that all electrical and electronic products must be strictly separated from household waste.

A specific recovery system for this type of product is in place in the countries of the European Union (*), Norway, Iceland and Liechtenstein.

Do not attempt to dismantle this product yourself. This can have adverse effects on your health and on the environment.

Refrigerant liquid, oil and other parts must be reprocessed by a qualified installer in accordance with applicable local and national laws.

In terms of recycling, this appliance must be processed by a specialised service and must not, under any circumstances, be thrown out with household waste, bulky waste or at a tip.

Please contact your installer or local representative for more information.

* Depending on the national regulations of each member state.



KIWA 00027/014 HP - Alféa Excellia A.I. 11
KIWA 00027/015 HP - Alféa Excellia A.I. 14
KIWA 00027/016 HP - Alféa Excellia A.I. tri 16



This equipment complies with:

- Low Voltage Directive 2014/35/EC in accordance with EN 60335-1 and EN 60335-2-40 standards,
- Electromechanical Compatibility Directive 2014/30/EC,
- Machines Directive 2006/42/EC,
- Pressure Equipment Directive 97/23/EC,
- Ecodesign Directive 2009/125/EC,
- Energy Labelling Directive 2010/30/EC.

This appliance also complies with:

- Decree No. 92-1271 (and its modifications) relating to certain refrigeration fluids used in refrigeration and air conditioning equipment.
- Regulation 842/2006 of the European Parliament on certain fluorinated greenhouse gases.
- Standards relating to the product and testing methods used: Air-conditioners, liquid chiller units and heat pumps with a compressor driven by an electric motor for heating and refrigeration EN 14511-1, EN 14511-2, EN 14511-3, EN 14511-4.
- EN 12102 standard: Air-conditioners, heat pumps and dehumidifiers with compressor driven by electric motor. Measurement of airborne noise. Determination of the level of sound power.



Keymark Certification:

012-SC0136-19 - Alféa Excellia A.I. 11 / 012-SC0135-19 - Alféa Excellia A.I. 14 / 012-SC0137-19 - Alféa Excellia A.I. 16tri

Commissioning date:

Contact details of your heating engineer or After Sales service.



www.idealheating.com

Ideal, P.O. Box 103, National Ave,
Kingston Upon Hull, HU5 4JN.
Tel. 01482 492251 Fax. 01482 448858.

Registration No. London 322 137.