

One Hour Fire Rated Drop Down Loft Access Door - Rectangular

Code: **GL280F** Standard

**GL281F** Lockable

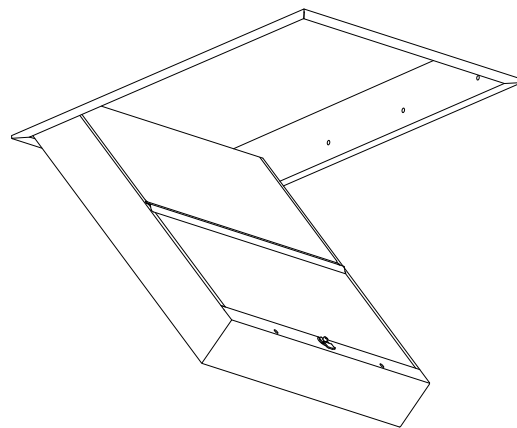
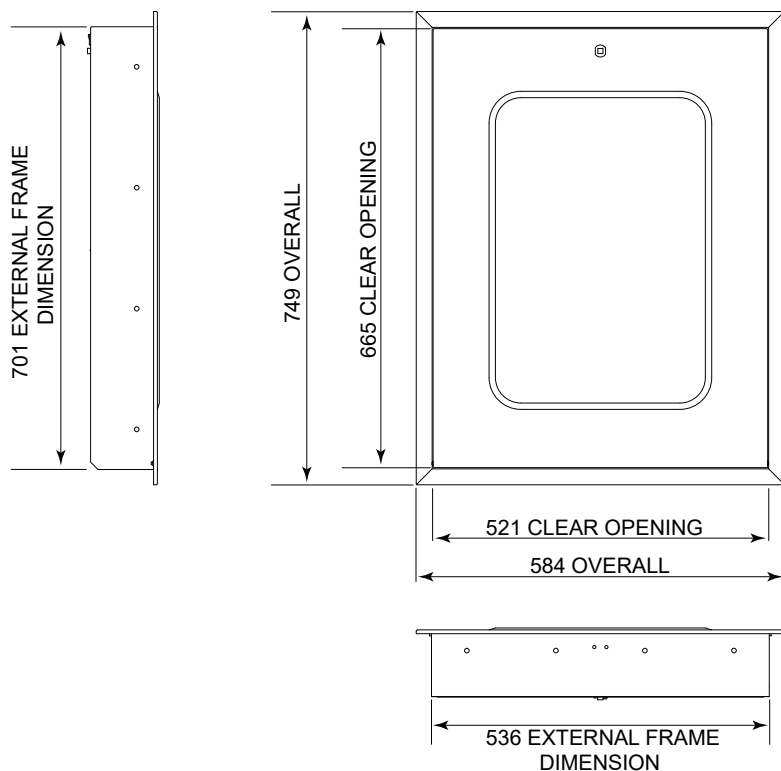

### Description

The **GL280F** Drop Down One Hour Fire Rated Loft Access Door is designed to be flush fit to the ceiling and to fit between 600mm truss rafter centres. The sleek, modern design fits in with almost all house decor styles. Finished in white with a light texture, the door can be easily cleaned with a solvent free, damp cloth, or alternatively can be painted to match the surrounding decor.

Draught seals are located to all 4 sides of the door and seal to the frame held in place with a robust latch preventing the problem of moist, warm air entering the roof space.

The Fire Rated Loft Door (GL280F) comes with a budget lock and 'T' key as standard, or can be supplied with a more secure CamLock key lock (GL281F).

**The GL280F fire rated access door met the British Standard recommendation for a leakage rate of <math>1\text{m}^3</math> at a pressure differential of 2 Pa, and the Building Regulations Part L2A 'reasonable limit' for the design air permeability of buildings of  $10\text{m}^3/\text{h.m}^2</math> at 50Pa.$**

**Note:** GL281F Includes a CamLock Key Lock

### Specification

Packing Details	Individually Packaged in Cardboard Box
Material	Zintec Mild Steel finished in Polyester Powder Coating (White)
Seal	PVC Foam
Insulation	Mineral Fibre (@100mm depth)
K-Value (Insulation)	0.035 W/mK
U-Value (Insulation)	0.35 W/m <sup>2</sup> K
Box Weight	10.0 Kg
Air Leakage Test	BRE No 233677
Fire Assessment	WFRC No 516268

### References

BRE	Digest 262
BSI	BS 5250
DOE	Building Reg L1, L2
NHBC	Standards 7.2
BS EN	1364: Part 2
BS	476: Part 22

MANTHORPE BUILDING PRODUCTS LTD  
MANTHORPE HOUSE  
BRITTAIN DRIVE  
CODNOR GATE BUSINESS PARK  
RIPLEY  
DERBYSHIRE DE5 3ND

TEL: 01773 303 000  
FAX: 01773 303 300  
EMAIL:  
mbp.care@manthorpebp.co.uk  
WEB:  
www.manthorpebp.co.uk

Drawn  
MA 27.08.03

Issue  
BH 27.10.22

DRG No

Issue

The company maintains a policy of continuous development of its product range and reserves the right to amend the specification without notice.

**MBP 8196**

**10**