



## LiteSlate Installation Guide

[sales@britmet.co.uk](mailto:sales@britmet.co.uk) | 01295 250998 | [www.britmet.co.uk](http://www.britmet.co.uk)

**RAISING THE STANDARDS IN LIGHTWEIGHT ROOFING**

<b>Contents</b>	<b>Page</b>
Tools, storage, conditions and cold weather installation	3
Product information	4
Installation Guidelines	6
Starter/Eaves course	6
Preparation	6
Hip roof layout	7-8
Fully boarded roof	9-10
Batten roof	10-12
Fixing Ridge/Hip caps	13-15
Valleys	16
Flashings (apron/step flashings/vent flashings)	16-18
Pitch changes	18
Chimney saddles	19
Hip installation on a boarded roof	20
Hip installation on a felt & batten roof	21-22
Installation in high-wind areas	22-23
Conical roof installation	23-24
Removing/re-fitting LiteSlate	25-26
Warm roof installation	27
Cold roof installation	27-28
Ventilation	28-29
Accessories	30

# Product Information

## No special tools required

- ✓ Hand fastened (hammered or screwed) or fastened with a nail/screw gun
- ✓ Tape measure
- ✓ Heat gun
- ✓ Tin snips
- ✓ Pry bar
- ✓ Chalk (do not use red chalk)
- ✓ Sharp utility blade/standard circular saw/Jigsaw

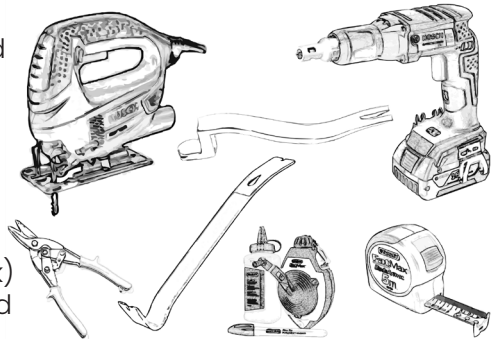

## Storing LiteSlate

For proper installation, the slates need to be stored on the original pallet on a flat surface. Proper storage of the product at the job site is important. The slates are cambered to ensure that maximum pressure is transferred to the leading edge of the slate during installation. Do not double stack pallets.

## Conditions

Perform work when existing and forecasted weather permits. Work should be performed safely and professionally, when ambient weather conditions are within the limits established by Britmet.

## Storage

LiteSlate should not be stored on roof decks in such a manner as to over-stress and/or damage the deck and supporting structure.

## Cold weather installation

LiteSlate should be stored in the original packaging in a storage facility where the temperature meets or exceeds 6°C. Use protective coverage over all pallets while being temporarily stored on-site. LiteSlate must be conditioned at a temperature no lower than 6°C for 24 hours before use. LiteSlate may be installed at temperatures as low as 0°C but must be hand fastened - **the use of a pneumatic gun below 6°C will result in cracking and webbing in the fastened area.** Be sure to follow the manufacturer's installation requirements for all underlay or membrane and any other applications. Comply with any local building regulations. **Note: The slates can be slippery under certain conditions and job site safety procedures should be enforced.**

# Product Information

## Product Description

LiteSlate is manufactured from a recyclable blend of limestone and polypropylene and is made from multiple natural patterns. The slate measures 442mm in height and 297mm in width.

<b>Overall height:</b>	442mm	<b>Minimum Pitch:</b>	12°
<b>Overall width:</b>	297mm	<b>Maximum Pitch:</b>	90°
<b>Weight (per sqm):</b>	12kg	<b>Weight (per slate):</b>	0.6kg
<b>Packaging:</b>	Pack: 22 slates Pallet: 72 packs	<b>Batten Size:</b>	50mm x 25mm treated battens (minimum)
<b>Warranty:</b>	50 Years	<b>Drilling:</b>	No drilling required
<b>Roofing membrane:</b>	Impermeable (non-breathable) Type HR roofing membrane.	<b>Roof Decking Materials:</b>	18mm plywood decking, solid wood decking, or oriented strand board (OSB)
<b>Fixing:</b>	Large-headed galvanised 30mm x 2.5mm steel nails/screws. Aluminium or copper nails may also be used, but driving them through the slate may cause bending. Longer 50mm nail/screw required for fixing ridges and hips.		

**Please note: the diagrams in this guide are for illustration purposes only, actual sizes and/or placement may vary from those shown. If in doubt, please contact our technical department: 01295 250998.**

## Fastener Recommendations

Slates should be fixed using two galvanised/stainless steel or copper fasteners with a minimum 10mm diameter head and a minimum length of 30mm. Corrosion-resistant fasteners are always recommended, especially in coastal areas. The length of the Hip & Ridge fastener should be a minimum length of 50mm.

**Note: Caution should always be used to ensure against over/under penetration of the fastener. Do not overdrive the fastener.**

The fastener head should be contacting the slate within the centre of the nailing target circle. Improper fastening can compromise the roof system and void the manufacturer's warranty.

## Recycling

LiteSlate is designed with the environment in mind. LiteSlate is manufactured using over 90% recycled polymers and is 100% recyclable at the end of life.

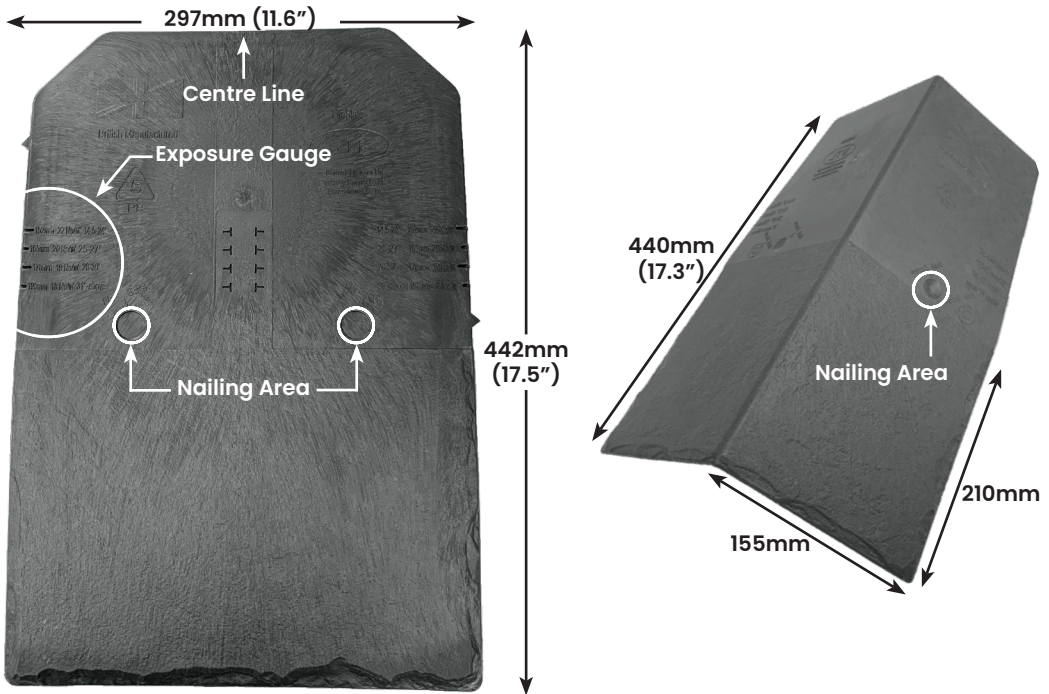

Roof Pitch:	Gauge:	Slates per m <sup>2</sup> :
12 to 25° (fully boarded or felt & battens)	152mm	22
25 to 27.5° (fully boarded or felt & battens)	165mm	20
27.5 to 30° (fully boarded or felt & battens)	178mm	19
above 30° (fully boarded or felt & battens)	190mm	18

## Roof Ventilation

**Ridge:** Felt underlay/board to be cut back allowing a 12.5mm air gap on either side of the centre line of the ridge. If necessary, cut the top course of LiteSlate to suit the roof dimensions (allowing the 12.5mm air gap). Fix the LiteSlate ridge vent strip on top of the top course and overlay the LiteSlate ridge and fix it in accordance with the manufacturers instructions.

**Eaves:** Fix LiteSlate eave vents on top of fascia board, 10mm vent for 15° and above, and 25mm for roof pitches less than 15°. Eave vents should be in line with the top of the battens, and fit a lay board of tilting file at the eave if appropriate, to ensure any moisture drains into the gutter.

# Installation Guidelines

## Spacing between the slates

---

6mm (0.25") spacer tabs are provided on every slate to aid in maintaining consistent spacing. The spacers will allow for any movement of the roof deck and expansion/contraction of the slate (although thermal expansion is highly unlikely in UK/European climates).

**Note: DO NOT remove the spacer tabs unless finishing at the end of the course.**

## Starter/Eaves course

---

When beginning or finishing with a cut piece of slate, the cut edge should be installed inward. The manufactured edge should be installed on the outside edge of the roof. This is to maintain an acceptable roof appearance along the gable edge of the roof. The centre mark of the slate can be used as a guide to cut ½-slates. This can also be used as a guide to keep courses straight and to assist in maintaining the proper slate 6mm (0.25") spacing when aligning with intermittent vertical chalk lines.

**Note: DO NOT install slates smaller than 76mm (3").**

## Preparation

---

Inspect all areas of the roof surface to be covered.

1. The surface area must be uniformly flat, smooth, sound, clean and free of anomalies.
2. Examine roof sheathing to verify that sheathing joints are supported by framing and blocking and/or metal clips.
3. Verify that the substrate is sloped for drainage and completely anchored to sound framing. Any foreign particles shall be cleaned from interlocking areas to ensure proper seating and to prevent moisture intrusion and ice damming. Proper provisions must be made for flashings and roof penetrations.
4. Even though metal flashing and other special flashings may not be the responsibility of the roofing contractor, these items must be in place before the roof slate installation. Work by other trades which penetrate the roof plane must be completed.

## Hip roof layout

1. Initial starting points may be from the left side, right side or centre of the area to be installed. 6mm (0.25") spacer tabs are provided on every slate.
2. A full slate should be cut into  $\frac{3}{4}$  size, approximately 305mm (12"), to create an eave or starter slate for the starter course and at the ridge if necessary.
3. One method of starting on a hip roof is to locate the centre of the roof area to be covered. From both ends, position starter pieces and snap a horizontal line from the tops of the starters between these two points. Next, snap a vertical perpendicular line. This can be done easily by marking 0.91m (3ft) along the eave, then where 1.22m (4ft) and 1.52m (5ft) intersect will form a perpendicular line. As long as the ratio 3:4:5 stays the same this will hold, for example, 21:28:35. More horizontal and vertical lines may be snapped to ensure the roof slates will stay true and plumb throughout the installation. Begin by placing an eaves slate on the right and left side of the vertical line maintaining a 6mm (0.25") or 13mm (0.5") spacing, depending on the slate type used, and continue to both ends.
4. The eaves and first course should overhang a maximum of 38mm (1.5") at the eaves for the gutter oversail.
5. Begin the first course. With a full slate, align the centre locator line of the slate directly over the vertical chalk line. Continue to both ends, maintaining the 6mm (0.25") spacing, depending on the slate type used, between slates.

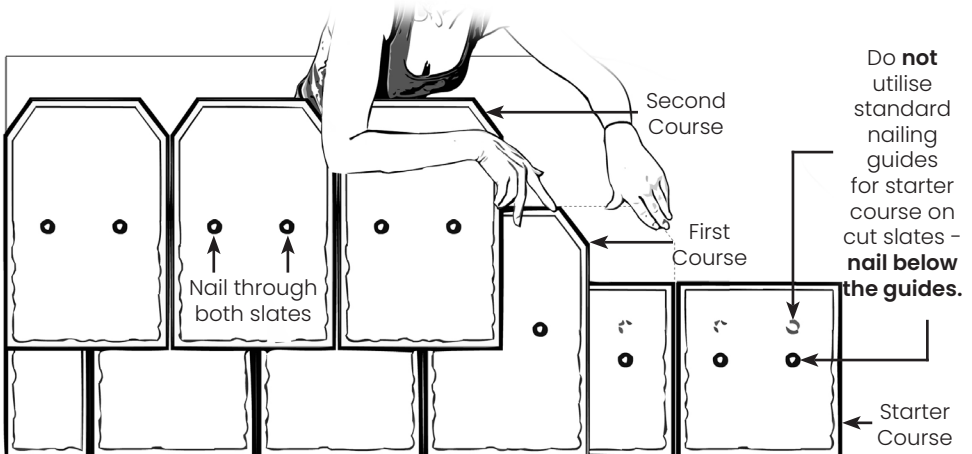

6. After installing the underlay/membrane, and before installing the LiteSlate, clean the surface of debris and dirt. Foreign particles should be cleaned and removed from interlocking areas to ensure proper seating of the product and to prevent moisture intrusion and ice damming. All roof penetrations shall be properly flashed and secured into position with deck and underlay or membrane fasteners properly driven and not protruding before installing LiteSlate.

a. The eaves or starter slates will be used as the first row at the eaves of the roof.

b. To create the offset from course to course, use the centre mark provided on each slate and cut the slate lengthwise. This ensures that the nail holes are covered with the next course of slates and no through-joints are exposed to the deck.

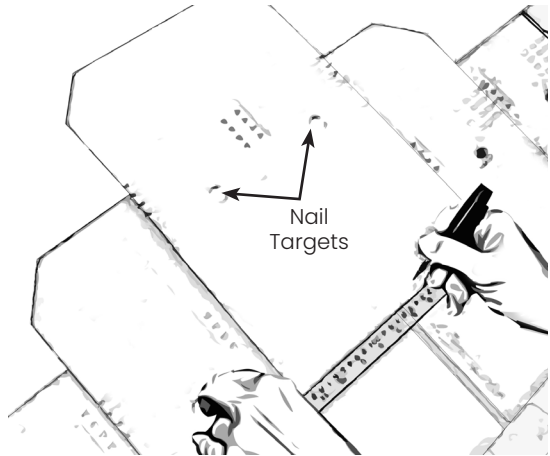

c. Strike the chalk lines horizontally, at the exposure level desired, to ensure that the slates are installed straight and uniform. Vertical chalk lines will help maintain consistency in the keyways.

d. Spacer tabs are provided on each slate to ensure consistent spacing between slates.

e. There shall be no through-joints from the roof surface to the underlay or membrane.

7. Each slate shall be fastened with a minimum of two galvanised, stainless steel or outdoor roofing fasteners (clout nails or screws).

a. It is required that the fasteners be placed within the two nailing targets on each slate. Flatten slate then fasten. The fastener must penetrate decking at least 23/32" (18mm).

b. Caution should be taken where the underside of the roof decking is exposed to view, such as overhanging eaves, where the nails or screws should be long enough to penetrate the roof decking but not so long that they may be driven through the decking.

8. Continue the second course with a full standard slate set back from the course below, the finished edge facing the gable edge. Align the full roof slate between the centreline locators from the lower course. Next, adjust the roof slate up or down to align the desired exposure lines with the top edge of the lower course.



## Fully Boarded Roof

The following instructions are just a guide, and standard roofing procedures should be applied. There is very little difference between LiteSlate and traditional slate in fully-boarded roof applications. The most cost-effective way to fix LiteSlate to OSB is to first use a vapour impermeable roof membrane/underlay, along with an air barrier on the warm side of the insulation for Cold Roof applications or an air and vapour control barrier membrane to the warm side of the insulation for Warm Roof applications. Alternatively, a vapour-permeable roof membrane/underlay can be used along with the application of counter battens on top of the membrane. The same vapour/air barriers are also recommended for Cold/Warm Roof applications using this counter batten method and a vapour-permeable roof membrane/underlay.

LiteSlate repels water and does not absorb it, this means that water penetration is non-existent from the roof surface itself. However, vapour/air barriers minimise the risk of moisture accumulating on the underside of the slates/OSB as the most common source of moisture is generated inside the property itself. Using a

vapour impermeable roof membrane/ underlay reduces this risk even further. The OSB sheeting should be a minimum of 18mm thickness.

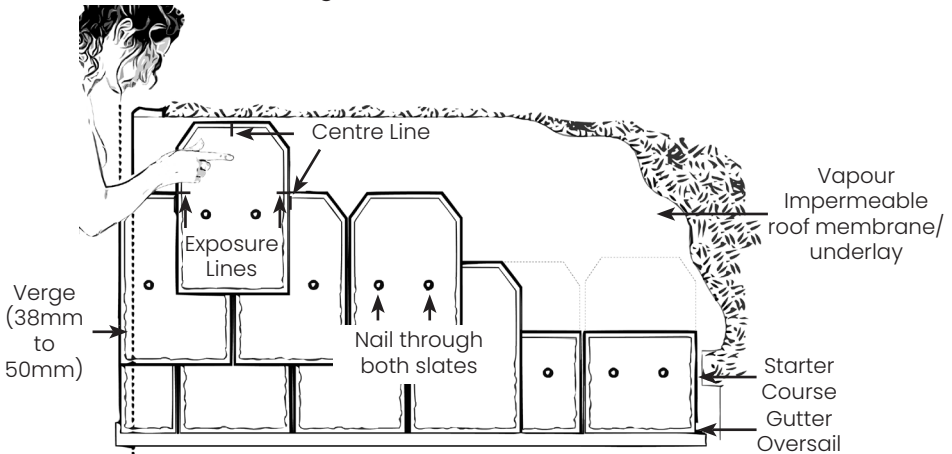

As can be seen in the diagram, LiteSlate can be nailed or screwed directly onto the OSB when using a vapour impermeable roof membrane/underlay. This is the most cost-effective method of fixing LiteSlate onto a fully-boarded roof.

## Felt & Batten Roof

The following instructions are just a guide, and standard roofing procedures should be applied. There is very little difference between LiteSlate and standard slate in batten roof applications. The most cost-effective way to fix LiteSlate to battens is to first use a vapour impermeable roof membrane/underlay, along with an air and vapour control barrier membrane to the warm side of the insulation for Warm Roof applications. No other barrier membrane is needed when using the vapour impermeable membrane in a Cold Roof situation. Alternatively, a vapour-permeable roof membrane/underlay can be used along with the application of counter battens on top of the membrane. The same air and vapour control barrier membrane is also recommended for Warm Roof applications using this counter batten method and a vapour-permeable roof membrane/underlay.

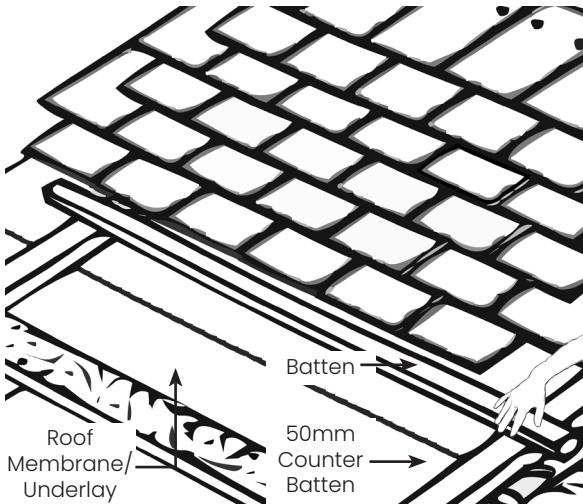

For felt and batten roofs, start by fixing battens (minimum size of 50mm by 25mm treated battens) over underlay to the required gauge. The first course and eaves (starter) course should oversail the fascia by at least 38mm, so the first-course batten should be placed approximately 190mm centrally from the start of the roof (see diagram).

A second batten should then be placed directly under the first-course batten to accommodate the eaves or starter course (made from a cut  $\frac{3}{4}$ -slate).

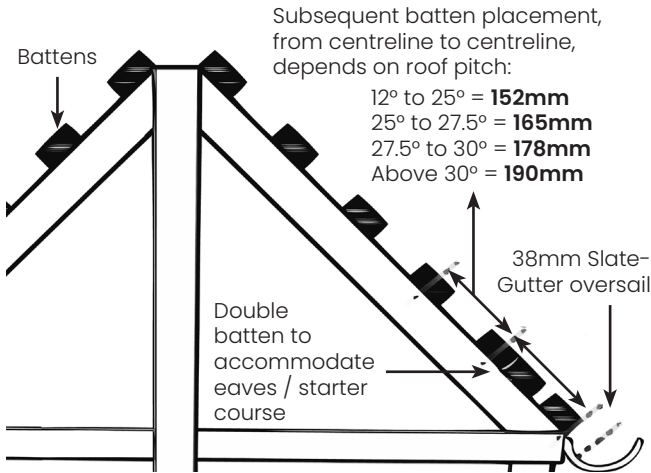

The distance from the first-course batten to the second-course batten, and beyond, is dependent on the roof pitch and subsequent slate exposure gauge settings. Please see the diagram of the LiteSlate and the Pitch, Gauge, and Coverage table on page 5.

The diagram above also shows an approximate guide to subsequent batten placement. The position of the top battens should then be established to ensure that the top course of slates will be covered by the ridge cap. Fix eaves, or starter course using a ¾-cut slate for LiteSlate which can be easily cut to size from a full slate using a fine-toothed hand/circular saw or a sharp utility blade. As stated earlier, the first course and eaves (starter) course should oversail the fascia by at least 38mm. This ensures water disperses into the centre of the gutter. This must be taken into account when calculating the gauge and positioning of the battens.

The required gauge and number of courses can then be calculated. The first course should sit on top of an eaves course. Double batten as shown in the diagram to accommodate the eaves slates.

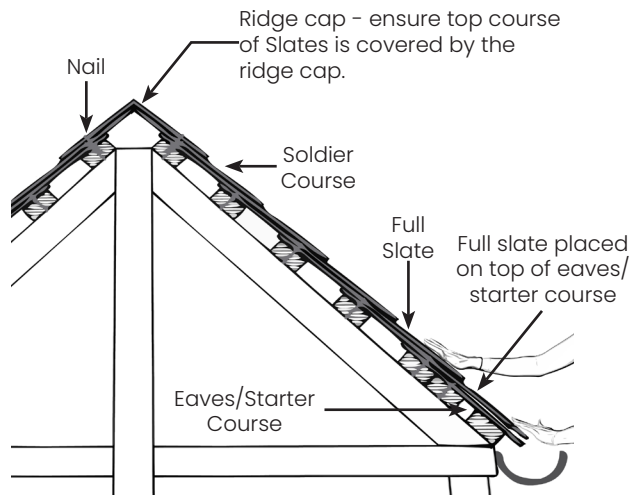

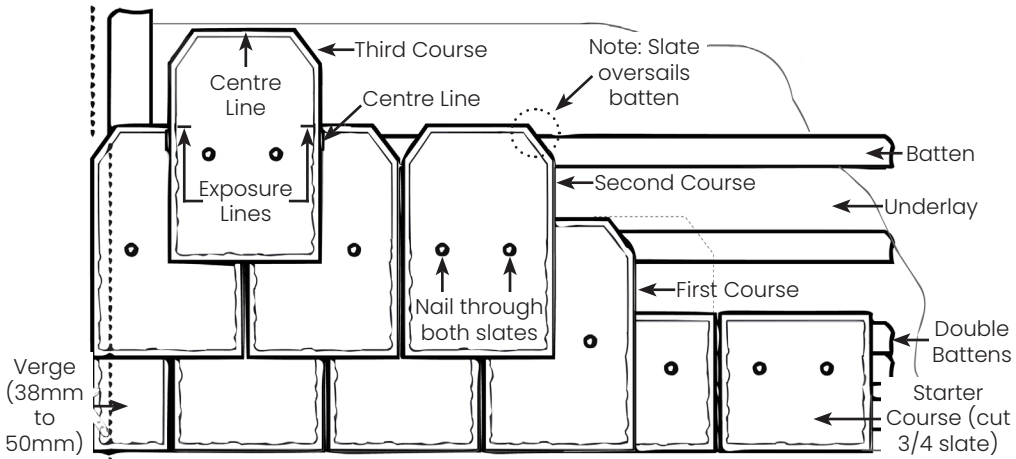

Verge slates should oversail the brickwork/barge board by 38mm, and may need to be cut to size at either end. Lay the first course of full slates over the eaves course and fix to the second batten. Ensure that the first course and eaves course are laid "broken bond" so that the joints do not line up and the weatherproofing integrity is maintained. Lay subsequent courses "broken bond" as illustrated. It will be necessary to cut to start and finish every other course.

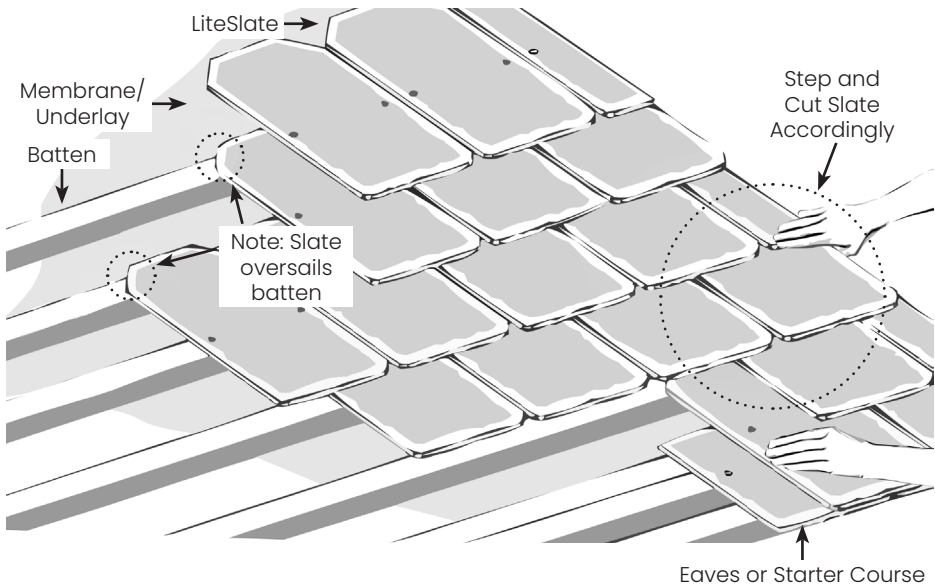

## Fixing Ridge/Hip Caps

Just like our LiteSlate, our ridge and hip caps have an exposure guide embossed onto them. Caps on the ridge must be fitted at a maximum of 190mm exposure (the minimum exposure of 150mm for high-wind/driving rain-exposed areas). Caps on the hips must be fitted at a 150mm exposure. All caps should be nailed/screwed through the one below, similar to the tile layout, and must be secured in the indicated spaces provided using two fixings; once completed, this gives four fixing points on all but the last end cap. **Do not over-expose the caps.** The minimum number of caps per linear meter is 5.5 (at a 190mm exposure). The maximum number of caps per linear meter is 6 (at a

### Ridge Cap (Exposure 190mm) Hip Cap (Exposure 150mm)

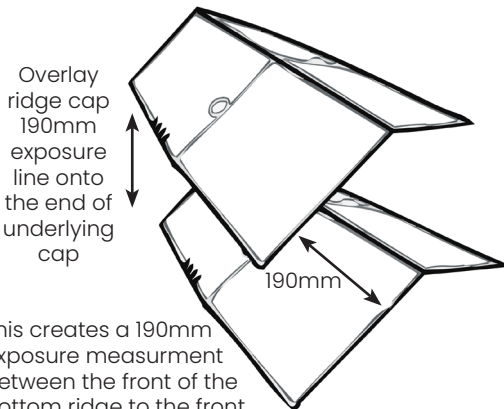

This creates a 190mm exposure measurement between the front of the bottom ridge to the front of the top ridge creating a tight seal against the elements: 5.5 per linear metre

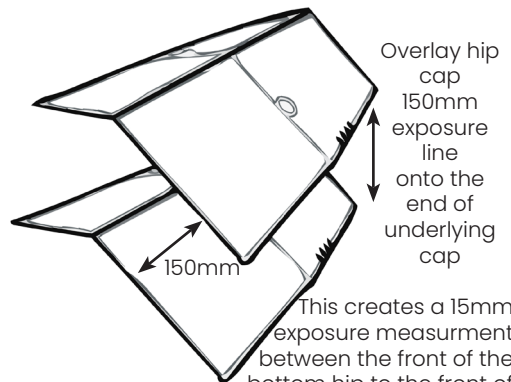

This creates a 15mm exposure measurement between the front of the bottom hip to the front of the top hip creating a tight seal against the elements: 6 per linear metre

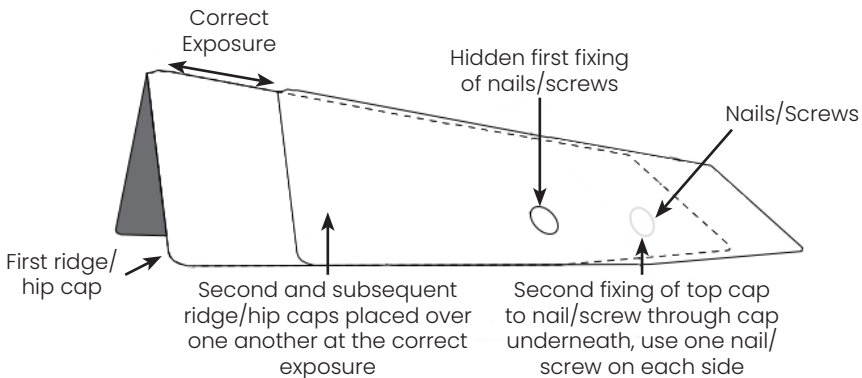

## Ridge/Hip Cap Finishing

**Ridge End Caps are available preformed.** Alternatively, LiteSlate Ridge Caps can be finished by cutting a standard LiteSlate at the end of the ridge into a triangle or diamond shape of the right size to cover the end gap. The resulting material should then be nailed in place into the end-battens and/or truss. The material can be sealed by using a good quality butyl or bitumen sealant (do not use silicone as this will not adhere). Alternatively, the material can be joined to the Ridge Cap by using a strong epoxy glue (adhering to the manufacturer's instructions). Nail heads should be disguised with coloured sealant or paint.

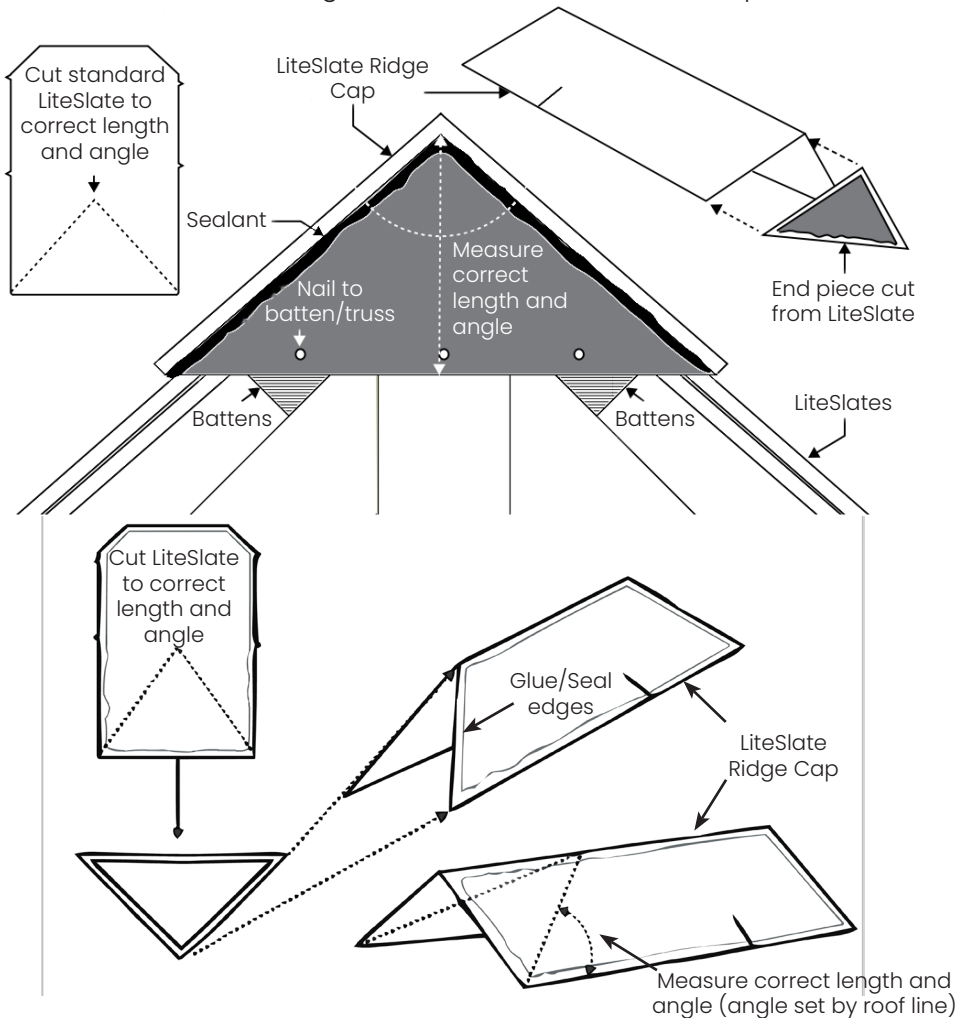

### 3-Way Ridge to Hip Junction flashing is also available preformed.

Alternatively, the same principle can be applied to an angular finish roof by measuring the roof angle and cutting a LiteSlate Ridge Cap to suit. A similar measurement can be applied to a standard LiteSlate to cut the right size and angle to cover the end hole in the Ridge Cap.

**Note: with an angular finish the material may have to be joined by using a strong epoxy glue (adhering to the manufacturer's instructions) unless there is enough batten/truss material to nail to.**

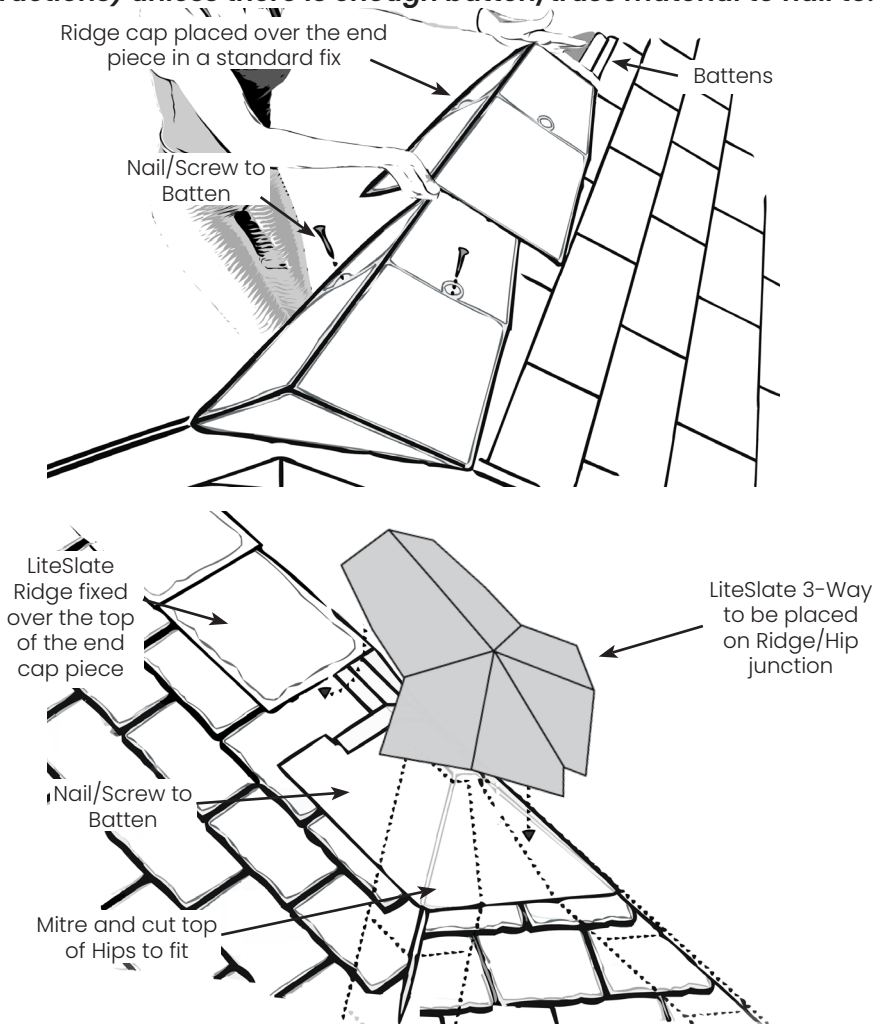

## Valleys

Open Valley Design:

1. Install a minimum 457mm (18") wide "W" valley or "I" seam valley.
2. Fasten the valley every 0.6m using metal cleats.
3. Slate over the valley by covering flashing by a minimum of 102mm (4").

**Note: Make sure not to drive fasteners from the slate into the valley flashing.**

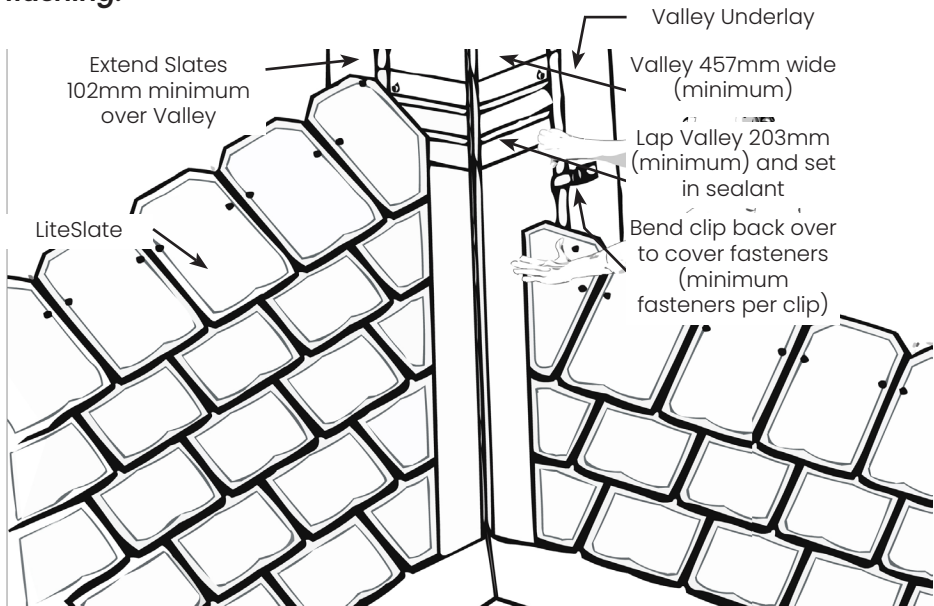

## Flashings

Flashings should be used around all roof penetrations such as walls, chimneys, dormers, parapets, vent pipes, skylights, etc.

**Note:** When dissimilar metals are placed in contact with one another, galvanic corrosion will result which can cause electropositive metals to deteriorate. One way this can be avoided is by placing strips of sheet lead between the two metals. When using lead, ensure that a coat of patination oil is applied. Britmet does not warrant metal components and accessories.



## Apron (Roof to Wall) Flashing

Apron flashing is used when a roof terminates to a wall causing a course to be cut and the face nailed. It is installed over the slates and behind siding or counter/cap flashing or dressed into brickwork/stonework, etc.

## Step Flashings

Step flashings are used over or under the roof coverings and are turned up on the vertical surface. Step flashings should extend under the uppermost row of the roof slate the full depth of the roof slate or at least 102mm (4") over the roof slate immediately below the flashing. The vertical leg of the flashing should be turned up a minimum of 102mm (4") and extended 102mm (4") on the roof slate with a 19mm (3/4") hem. Flashings should have a minimum length of 229mm (9") and must overlap a minimum of 51mm (2").



## Vent Flashings

The normal type of roof vents or flashings can be used. Extended-life materials should always be used.

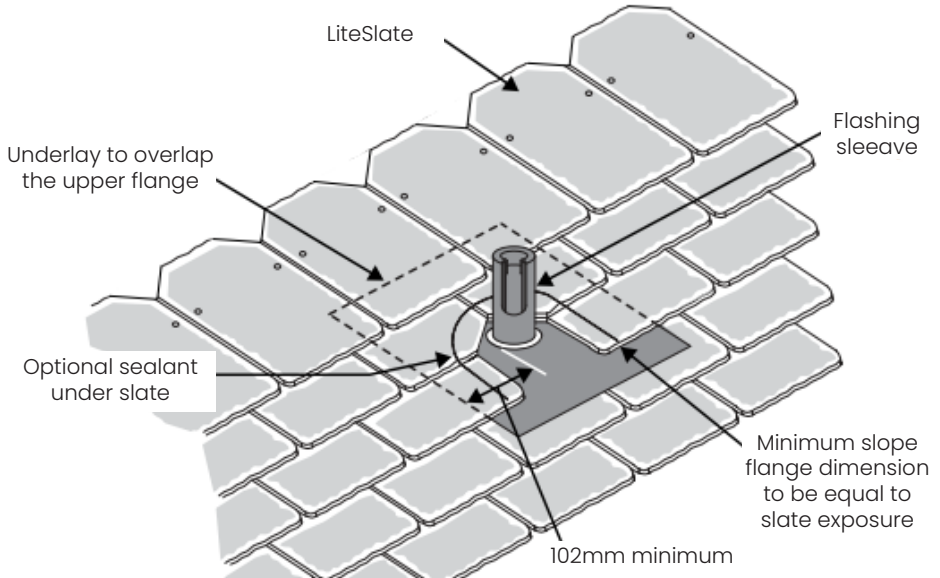

## Pitch Changes

LiteSlate can be installed onto rolling roofs with a gradual pitch change. Some roof designs, however, have drastic pitch changes where the use of flashing is necessary.

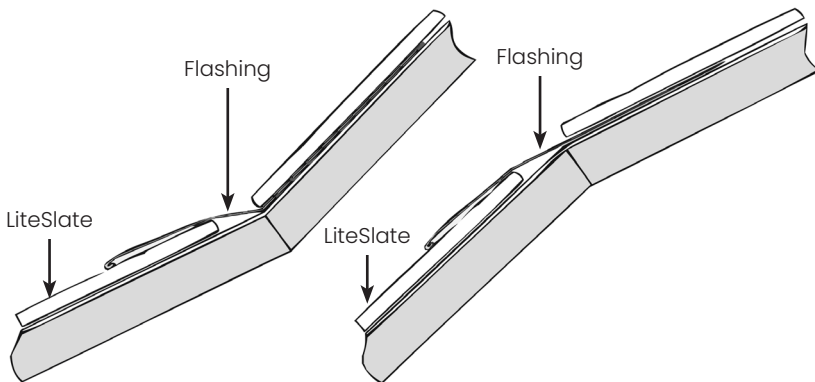

# Chimney Saddles

With chimneys more than 0.6m wide it is recommended that a saddle be installed to divert water from the back of the chimney. With chimneys, less than 0.6m may only require a simple pan flashing.

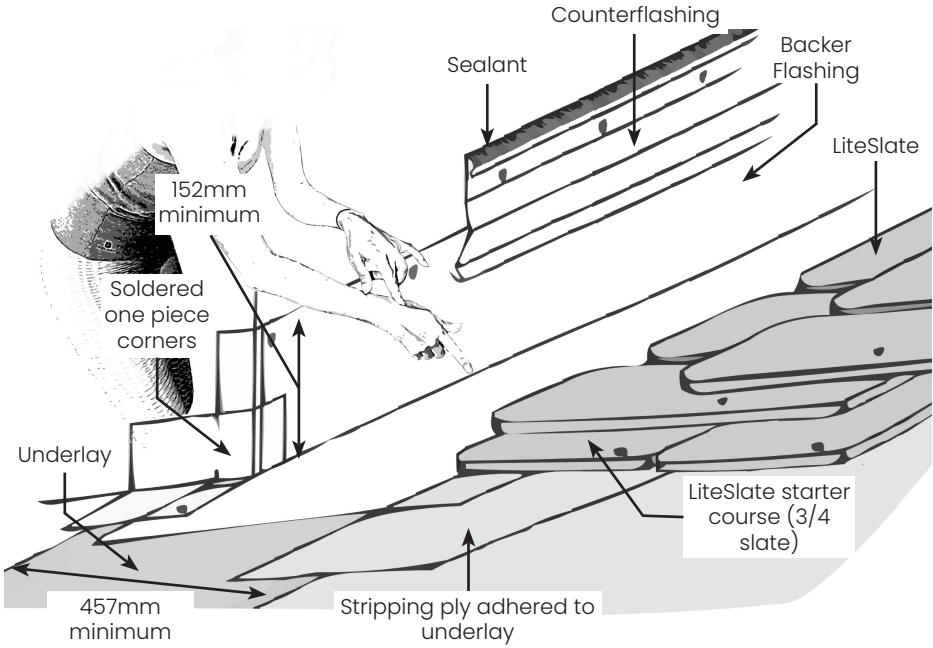

## Hip Installation on a Boarded Roof

When pre-formed hip & ridge slates are used, place the nail at fastener guide targets. Fasten hip slates with 2 nails (one on each side). Maintain a 152mm (6") exposure. Hip & Ridge Slate installation requires the slate to be nailed or screwed in place.

1. Chalk a straight line by placing one piece of the hip at the eave and one near the peak, holding the chalk line at the edge of the slate on the top and bottom pieces. This will help keep the hip straight in the event of a crooked hip.
2. Cover heads of fasteners with an adhesive sealant compatible with the roof slate in any case of exposure.
3. Ridge tiles require 152mm (6") exposure and require 51mm (2") length fasteners.
4. Fastener deck penetration must be a minimum of 19mm ( $\frac{3}{4}$ ").
5. Ridge end closure can be effected by cutting a triangular section from a slate and nailing to the ridge batten, or in the case of a boarded roof, to a timber fillet.

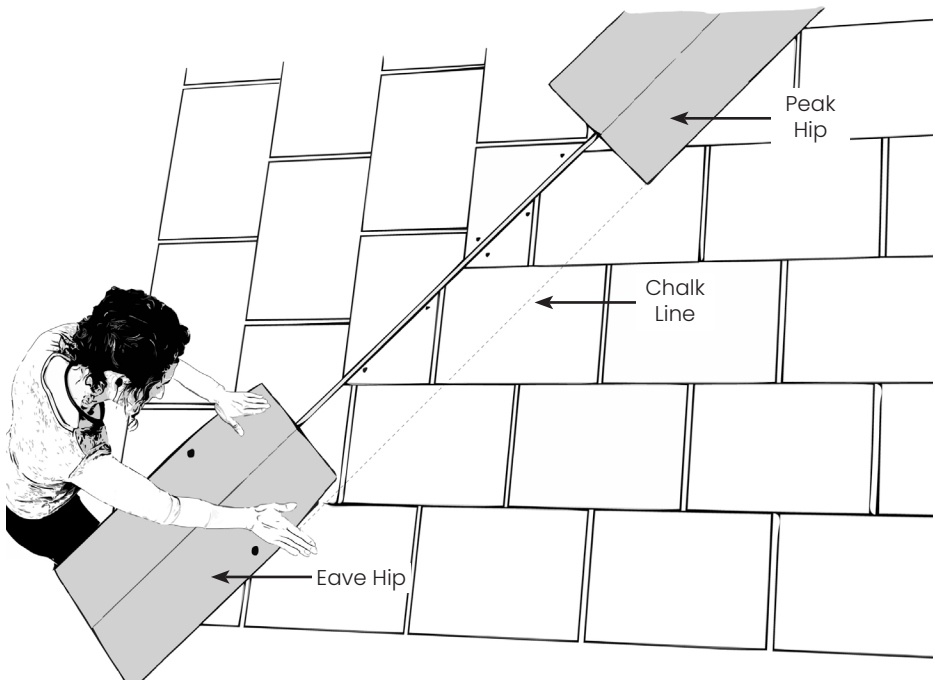

## Hip Installation on a Felt & Batten Roof

1. Cover the length of the hip with 600mm (24") underlay from eave to ridge, overlapping the standard underlay on either side of the hip.
2. Position the hip tile and mark the nailing points at the top and bottom of the hip.
3. Using these marks, secure a length of tiling batten on either side of the hip to provide a fixing point for the hip tiles.
4. The slating battens should be fitted flush to these hip battens.
5. Cut slates to fit at the junction.
6. Affix hip tiles using a minimum of 51mm (2") nails or screws.
7. Finish at the eaves with a cut-to-size-and-shape LiteSlate hip tile or preformed end caps. **(See the last page for more info)**

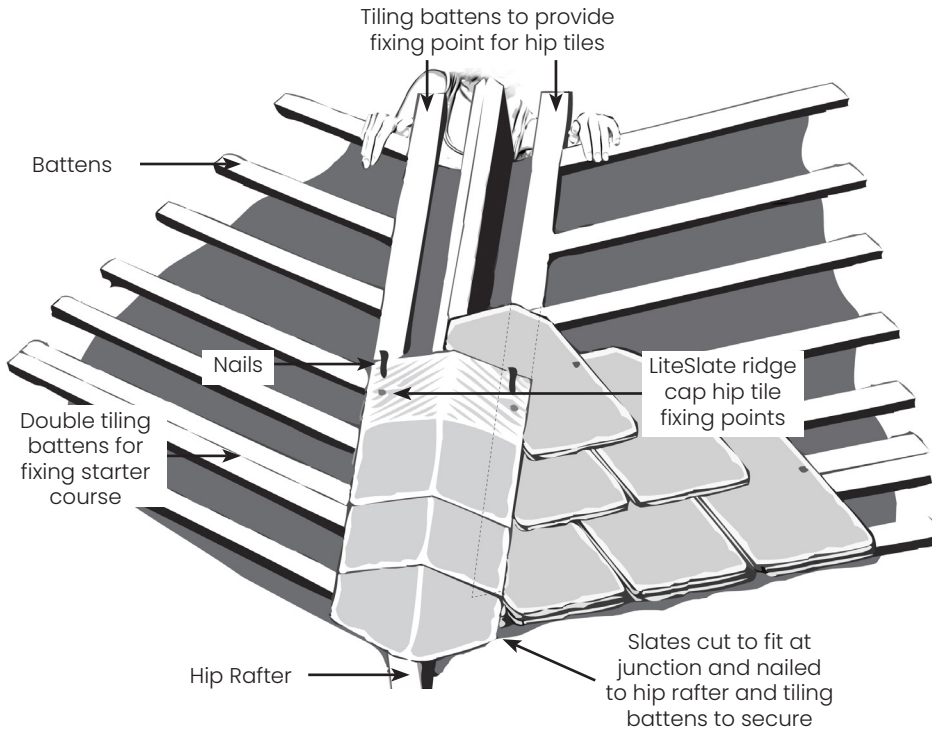

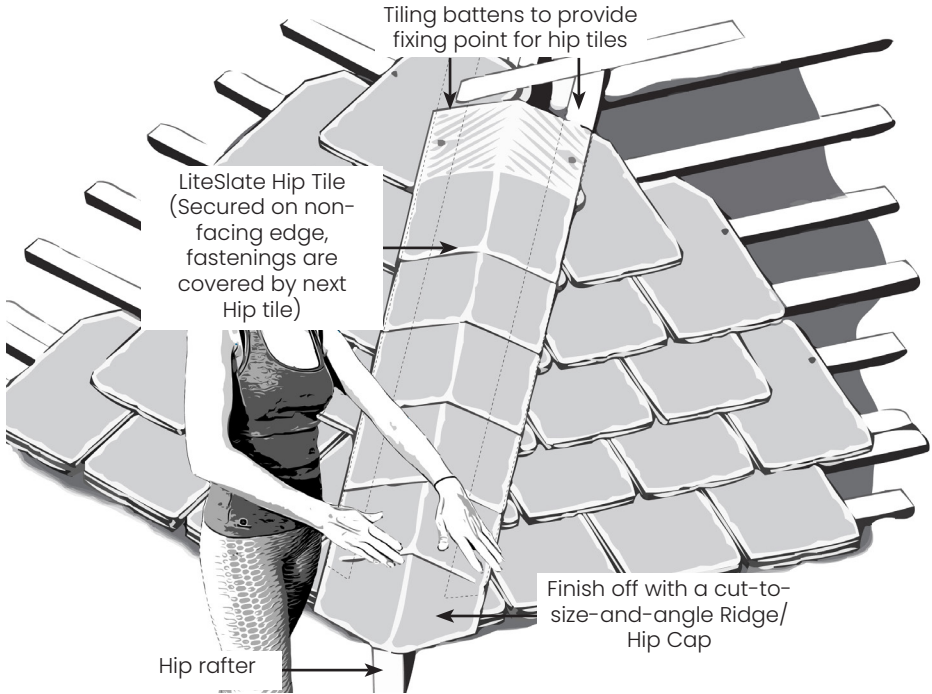

## Special Instructions

### Installation in High Wind Areas

LiteSlate has been tested for resistance to wind-driven rain/wind uplift. However, there are certain areas, particularly on west-facing coasts and exposed islands, where wind speeds can exceed this level, and in order to reduce the risk of uplift, the following installation instructions should be followed:

1. LiteSlate should be fixed directly to a solid substrate, such as sarking board, OSB or weather-grade ply.
2. The maximum overlap (slates set at the 152mm gauge) should be used.
3. Standard copper roofing rivets should be installed: a hole is drilled in the overlapping or top slate, and a rivet is slid up between the gap in the two bottom slates (see diagram below). The rivet should be put in a position where it can be inserted through the hole and bent over. After a length of time, the rivets will naturally blend in with the slate.

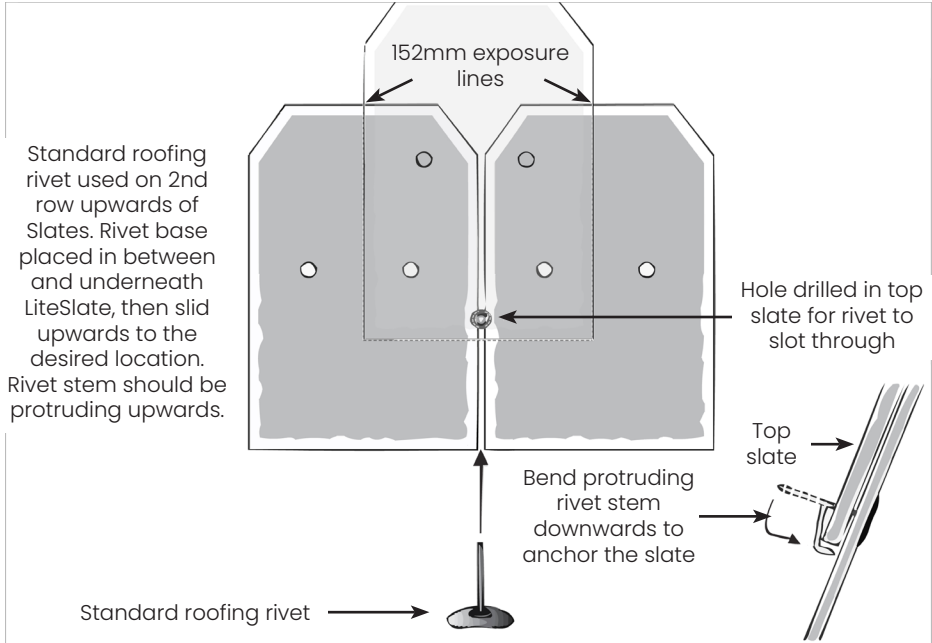

## Conical Roof Installation

Conical roofs (also known as turrets or cones) need custom cut slates that change depending on the radius and pitch. They can be quite difficult to install; **time and care must be taken during installation.**

1. Determine the taper by chalking lines originating at the peak, extending to eave spaced 292mm to 16mm apart for LiteSlate (the width of one slate).
2. Place the slate at the eave between the 2 lines, this will give you the proper taper for the first course.
3. Mark up your exposure from the top of your first slate. Repeat until you reach the top of the cone.
4. Each course will have a different taper as the pieces get smaller towards the top. You can now place a slate to each mark and determine the taper per course.
5. Be sure to pay attention to the size of the slates, If the slates get too small it may be necessary to use a larger slate and rechalk lines at some point.
6. Make sure measurements are periodically taken from eave and peak to ensure straight courses.

## Conical Roof Precautions

Roof slates may be slippery when wet or covered with frost. Fall protection equipment is required when working on a roof deck. The contractor may consider the use of toe boards. LiteSlate should be stored in temperatures above 6°C and the ambient temperature of the product must be at a minimum of 6°C during installation to avoid webbing and/or cracking of the roof slates.

Do not leave debris under the roof slates while installing, that will prevent the design of the roof slate from overlapping on the course below, thus allowing the potential for moisture build-up from wind-driven rain and/or ice dams.

Use accessory products with a lifecycle as equally long-term as the roof slates. Technical Bulletins should be reviewed and considered before the start of any project.

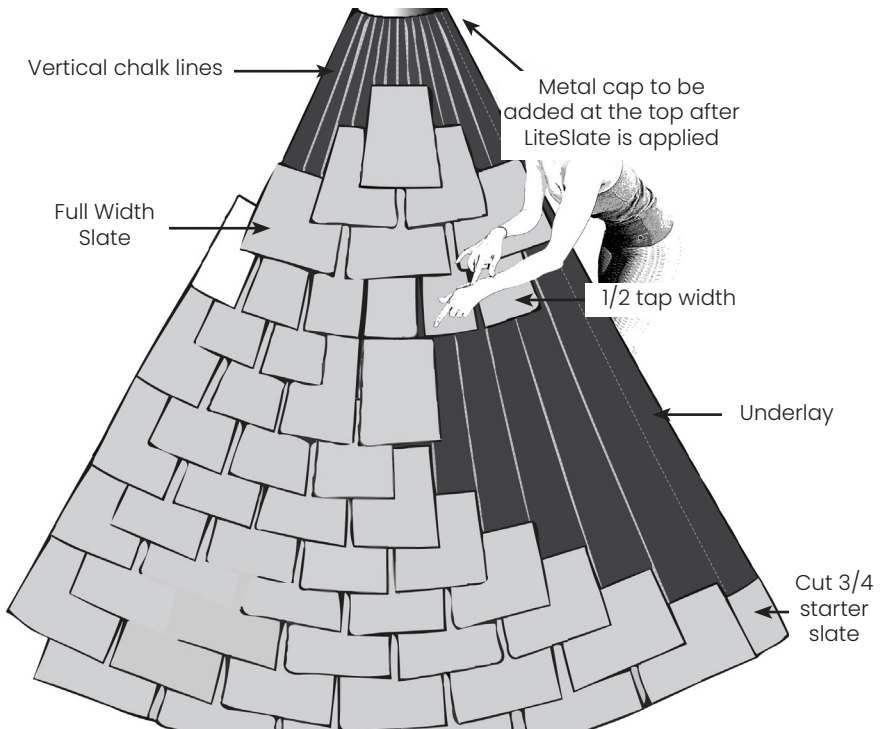



## Removing/Re-fitting LiteSlate

The removal and re-installation of individual slates can be achieved quite easily when the slates have been nailed into place, but more difficult if screws have been used to install the product.

### Nailed Install

The correct tools should be used for the removal and re-installation of the LiteSlate, we recommend a Vaughan SuperBar and/or a Roof Snake, a hammer and nails and a block of wood. On both the SuperBar and the Roof Snake, the forked end is used to slip under the tile above the one being removed to lift the nail and remove (the SuperBar's eyehole can be used to accomplish the nail removal as it will keep the tile above as flat as possible and avoid any distortion.)

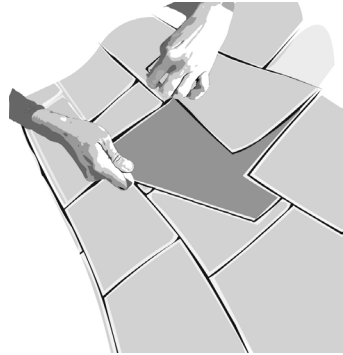

To replace the slate, it is handy to use a Roof Snake as it allows the installer to insert a new nail into the tool and use a hammer on the tool neck or a block of wood (which helps protect the slate surface) to drive the nail home. Alternatively, if not using a Roof Snake a second block of wood can be used similarly.

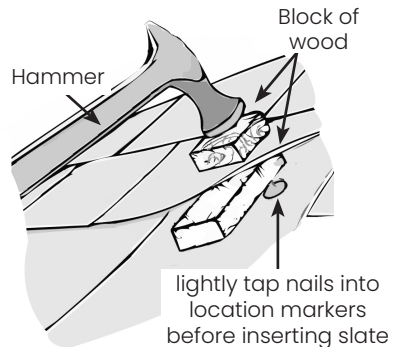
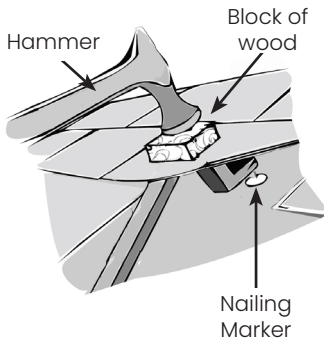

### Screwed Install

The correct tools should be used for the removal and re-installation of the LiteSlate we recommend a hand screwdriver and/or powered screwdriver/drill. To remove a LiteSlate that has been fixed by screws, the only way to achieve this is to remove a certain amount of other slates by unscrewing from the top of the roof downwards to the affected slate that you wish to remove. This will also involve removing ridge caps in the affected area unless the slate screws are easily accessible by lifting the caps with a pry bar. Before removing the slates, it would be best to label/number them in order of removal using masking tape and a pen/pencil. Always carefully and systematically stack the slates in order of removal so that they can be placed back in the same place.

**Please note: that over time there will be a certain amount of uniform weathering on the roof slates, and so a brand-new slate will never completely match the older ones at first until this too has weathered in over some time.**

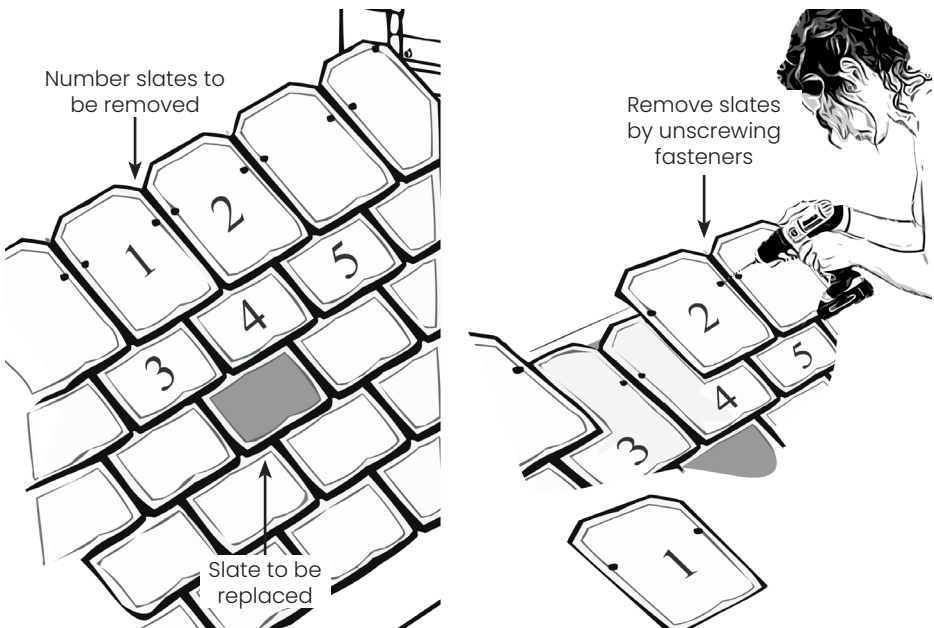

Replacement of the removed slates is the same process in reverse, replacing the carefully stacked and labelled slates in the order they were taken off, taking care not to over tighten the screws and replace any other slate tiles or ridge/hip that may have been damaged during the strip-down process.

# Warm & Cold Roof Structures

## Warm Roof Installation

---

When installing LiteSlate onto either batten or directly onto OSB, a vapour impermeable (type HR) roof membrane/underlay should be used. Insulation should follow the line of rafters, with a 50mm deep void between the top of the insulation and the underside of the underlay/OSB. This void is to be ventilated following BS 5250. An air and vapour control barrier membrane to the warm side of the insulation must also be installed, we recommend the Protect VC Foil Ultra-low emissivity air and vapour control layer product. **Please note: this chapter on warm roof installation is purely manufacturers guidance and should not supersede local building authority recommendations.**

A 50mm void between the insulation and the underside of the underlay/OSB should be maintained (a 25mm minimum void at the drape of the underlay if fitting to felt & battens), ventilated at low- and high-level following BS 5250. A Vapour Impermeable (Non-Breathable) roofing membrane/underlay should be used. This stops water vapour from forming on the underside of the slates and so can be removed by the ventilated airflow. **Please note: 18mm thick OSB or Ply to be used on fully boarded structures to avoid fixing penetration to the underside of the board.**

LiteSlate can then be fitted directly to board or battens if using an impermeable roofing membrane. Use the pre-formed fixing holes, spacers at each side of the slates and slate exposure guides for layout in broken bond. Remember to use a starter or eaves course to begin slate courses. An Air & Vapour Control Barrier membrane must be installed on the warm side of the insulation (underneath the ceiling plasterboard). This helps to prevent water vapour from even reaching the roof structure.

## Cold Roof Installation

---

When installing LiteSlate onto either battens or OSB a vapour impermeable (type HR) roof membrane/underlay should be used. When installing directly onto OSB, ventilation following BS 5250 to the loft void should be adhered to. Insulation should be installed on the horizontal ceiling below. To further enhance this construction, improve the thermal performance of all insulation by reducing convection flow and help to avoid interstitial condensation risk within insulation following BS 5250, we would recommend installing an air barrier on the

Warm side of the insulation, a suitable product would be an air barrier membrane with some vapour control properties. Insulation should be installed on the horizontal ceiling, typically rolls of rock, glass or mineral fibre.

Low-level and high-level ventilation following BS 5250 to the loft void should be adhered to. A Vapour Impermeable (Non-Breathable) roofing membrane/underlay should be used to stop water vapour from forming on the underside of the slates and will be removed by the ventilated airflow. **Please note: 18mm thick OSB or Ply to be used on fully boarded structures to avoid fixing penetration to the underside of the board.**

LiteSlate can then be fitted directly to board or battens if using an impermeable roofing membrane. Use the pre-formed fixing holes, spacers at each side of the slates and slate exposure guides for layout in broken bond. Remember to use a starter or eaves course to begin slate courses. To improve the thermal performance of the insulation, an Air Barrier Membrane fitted to the warm side of the insulation (underneath the ceiling plasterboard) is recommended. **Please note: that this information on cold roof installation is purely manufacturers guidance and should not supersede local building authority recommendations.**

## Ventilation

### British Standard (BS) 5250

BS 5250 stipulates guidelines with regards to roofing ventilation and condensation. Its primary concern is to eradicate condensation, which is mainly generated from within the home, from reaching and destroying the roof structure timber. Even when timber is not used in the roof construction, the vapour still needs to be properly extracted to prevent it from affecting other parts of the dwelling place. As with many other roof coverings, LiteSlate is classified as an “Insufficiently Air Open” product, meaning that water vapour cannot vent to the atmosphere directly through the tiles, and so provision must be made to ventilate the roof space to move the water vapour from inside to outside the property. Proper ventilation is an essential part of modern-day roofing.

BS 5250 requires all roof structures to be ventilated at both low-level (air moving into the roof), which is typically at the eaves or soffit and at high-level (air moving out of the roof), which is typically at the ridge/hip, abutment, or with the use of fixed ventilation units.

Obstructions such as dormers, valleys, roof windows, compartment walls, fire barriers and changes in pitch create separate voids below the roof slope. Ventilation openings should be provided to each void at a high and low level.

## **Low-level Roof Installation**

---

On a warm roof, a 50mm void following the line of the rafters should be maintained and on a cold roof, the loft space needs to be ventilated. These kits achieve this while keeping debris and insects from blocking the airflow. The eaves ventilation strips install continuously along the eaves and provide ventilation openings of 10,000mm<sup>2</sup>/m (cold roof) and 25,000mm<sup>2</sup>/m (warm roof) respectively. A rafter ventilation roll, will be required but this will need to be purchased separately if using felt & batten construction.

### **Fully-Boarded Roof**

The over-fascia vent is fixed onto the fascia board and sits underneath the OSB or ply. The protective skirt covers the vent and the roofing membrane is then laid on top of the skirt and the rest of the roof. Airflow comes in from underneath the vent and flows up the roof underneath the OSB/ply.

### **Felt & Batten Roof**

The over-fascia vent is fixed onto the fascia board and the protective skirt fits on top to protect the vent. For felt & batten installations we advise fitting a Rafter Ventilation Roll along the span. The roofing membrane sits on top and battens can then be fixed.

## **High-level Roof Installation**

---

High-level ventilation is needed for the low-level airflow to exit and vent water vapour to the atmosphere. Cross-flow ventilation (low-level to low-level) is inadequate as standard air pressure is too low to adequately vent water vapour in this way. The use of the ridge and hip ventilation system is recommended in both warm roof and cold roof construction when installing LiteSlate. The ridge vent strips are again recommended in both scenarios for roofing abutments (such as lean-to roofs).

# LiteSlate Accessories



3-Way Ridge to Hip

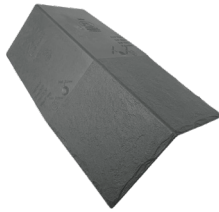

Ridge



Tile Vent (25-90°)

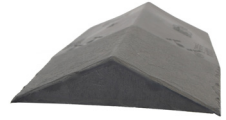

Ridge End Cap

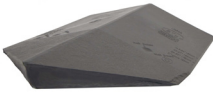

End Cap 90

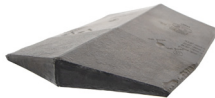

End Cap 135

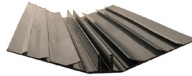

LiteSlate Valley

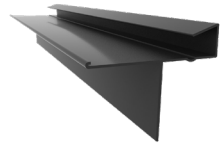

LiteSlate Verge



Pipe and Adaptor



Soaker



Verge Connectors



Ridge Vent



Eaves Vent



30mm Screw



50mm Ridge Screw



1m Membrane

If you require any further assistance, please contact our technical team on 01295 250998.