



THE CATALOGUE



FASTENERS & FIXINGS

JCP CONSTRUCTION PRODUCTS

TRADE AND RETAIL PACKS

AGRICULTURE & BUILDING

LOCKS & ACCESSORIES

HARDWARE & IRONMONGERY

ABRASIVES

SEALANTS & ADHESIVES

EXTRA^MEC

fastening supply specialists





CONTENTS

1	FASTENERS & FIXINGS	001
2	JCP CONSTRUCTION PRODUCTS	195
3	TRADE & RETAIL PACKS	253
4	AGRICULTURE & BUILDING	291
5	LOCKS & ACCESSORIES	319
6	HARDWARE & IRONMONGERY	337
7	ABRASIVES	405
8	SEALANTS & ADHESIVES	423
	INDEX	447
	TERMS & CONDITIONS	453

VORTEX[®]

The multi-purpose
POWER SCREW



- A Recessed countersunk
- B Sharp milling nibs
- C Double countersunk head
- D Sharp, wide and deep thread
- E Sawfix serrated thread
- F Oblique-angle gash point
- G Sharp gash point

Vortex™ – the multi-purpose power screw is technically-advanced, including ‘Sawfix’ technology, which quickly and easily powers through a wide range of materials, including hardwood, decking, MDF, plastic, and sheet metal, and many other applications.

The recessed double countersunk head on the Vortex™ product range reduces the likelihood of shearing the head of the screw, whilst assisting the completion of countersinking, making it a more reliable product for users.

The sharp, wide and deep thread on the products feature ‘Sawfix’ serrated thread technology, enabling the product to quickly and easily power through surfaces, and can be used on a range of materials including hardwood, decking, MDF, plastic and sheet metal.

Product Codes Begin ZZV602 Product Group 4014

V60218CE	3.5 × 12mm	CE	200
V60219CE	3.5 × 16mm	CE	200
V60220CE	3.5 × 20mm	CE	200
V60221FT	3.5 × 25mm		200
V60222FT	3.5 × 30mm		200
V60223FT	3.5 × 40mm		200
V60224CE	3.5 × 50mm	CE	200
V60225CE	4.0 × 20mm	CE	200
V60226FT	4.0 × 25mm		200
V60227FT	4.0 × 30mm		200
V60228FT	4.0 × 35mm		200
V60229FT	4.0 × 40mm		200
V60230CE	4.0 × 45mm	CE	200

V60231CE	4.0 × 50mm	CE	200
V60232CE	4.0 × 60mm	CE	200
V60233CE	4.0 × 70mm	CE	200
V60249FT	4.5 × 40mm		200
V60250CE	4.5 × 50mm	CE	200
V60251CE	4.5 × 60mm	CE	200
V60252CE	4.5 × 70mm	CE	200
V60234	5.0 × 30mm		200
V60235	5.0 × 40mm		200
V60236CE	5.0 × 50mm	CE	200
V60237CE	5.0 × 60mm	CE	200
V60238CE	5.0 × 70mm	CE	200
V60239CE	5.0 × 80mm	CE	100

V60240CE	5.0 × 90mm	CE	100
V60241CE	5.0 × 100mm	CE	100
V60242CE	6.0 × 50mm	CE	200
V60243CE	6.0 × 60mm	CE	200
V60244CE	6.0 × 80mm	CE	100
V60245CE	6.0 × 100mm	CE	100
V60246CE	6.0 × 120mm	CE	100
V60247CE	6.0 × 130mm	CE	100
V60248CE	6.0 × 150mm	CE	100
V60260CE	6.0 × 180mm	CE	100
V60261CE	6.0 × 200mm	CE	100



VORTEX® Assortment Cases



Code	Description	Case Qty
V60310CE	Assorted Case	1700
V60300CE	Box Assortment	1200

Clams

Product Codes Begin ZZVCL Product Group 4014

VCL60227CE	4 × 30mm	CE	200	VCL60236CE	5 × 50mm	CE	200	VCL60244CE	6 × 80mm	CE	100
VCL60229CE	4 × 40mm	CE	200	VCL60237CE	5 × 60mm	CE	200	VCL60245CE	6 × 100mm	CE	100
VCL60231CE	4 × 50mm	CE	200	VCL60238CE	5 × 70mm	CE	200	VCL60246CE	6 × 120mm	CE	100
VCL60232CE	4 × 60mm	CE	200	VCL60239CE	5 × 80mm	CE	100	VCL60248CE	6 × 150mm	CE	100
VCL60233CE	4 × 70mm	CE	200	VCL60240CE	5 × 90mm	CE	100				
VCL60235CE	5 × 40mm	CE	200	VCL60241CE	5 × 100mm	CE	100				

Tubs

Product Codes Begin ZZVTUB Product Group 4014

VTUB60229CE	4 × 40mm	CE	1600	VTUB60237CE	5 × 60mm	CE	800	VTUB60241CE	5 × 100mm	CE	600
VTUB60231CE	4 × 50mm	CE	1600	VTUB60238CE	5 × 70mm	CE	800	VTUB60245CE	6 × 100mm	CE	400
VTUB60233CE	4 × 70mm	CE	1000	VTUB60239CE	5 × 80mm	CE	700				
VTUB60236CE	5 × 50mm	CE	1000	VTUB60240CE	5 × 90mm	CE	600				



VORTEX® TX

Coming Soon

Ask your local sales office for more details

1 FASTENERS & FIXINGS

Ulti-Mate[®] II

• High Performance Wood Screws • The Professional's Choice



STATE OF THE ART **POZISQUARE[®]** AND **ACR[®]** ANTI-CAMOUT RECESS FOR 'STICK-FIT' AND 'STABLE DRIVING'



REINFORCED DOUBLE ANGLE HEAD
Self countersinking and resistant to screw breakage



SLOTTED SHANK
For reduced wood splitting



SELF CENTERING POZISQUARE[®] RECESS
Will also drive with PH and PZ Drivers



NEW QUICK-START POINT
Rapid starting with a minimum of force

Every box sealed with the **Genuine Phillips Drive System** hologram



Ulti-Mate[®] II also features: **TOUGHER NECK** • **ZINC & YELLOW PLATED** • **NO RIBS ON SMALLER SIZES** suitable for hinges and fittings

Ulti-Mate Woodscrews

Zinc and Yellow Passivated



PHILLIPS SCREW COMPANY
INNOVATION IN FASTENER TECHNOLOGY

Product Codes Begin **9ULTIMATE** Product Group **5062**

Article No.	Size	Box Qty.	Article No.	Size	Box Qty.	Article No.	Size	Box Qty.
OJ300121	3.0 × 12	200	OJ400456	4.0 × 45	200	OJ600504	6.0 × 50	200
OJ300206	3.0 × 20	200	OJ400500	4.0 × 50	200	OJ600603	6.0 × 60	100
OJ300251	3.0 × 25	200	OJ400609	4.0 × 60	200	OJ600702	6.0 × 70	100
OJ350126	3.5 × 12	200	OJ400708	4.0 × 70	200	OJ600801	6.0 × 80	100
OJ350164	3.5 × 16	200	OJ500309	5.0 × 30	200	OJ600900	6.0 × 90	100
OJ350201	3.5 × 20	200	OJ50040	5.0 × 40	200	OJ601006	6.0 × 100	100
OJ350256	3.5 × 25	200	OJ500507	5.0 × 50	200	OJ601303	6.0 × 130	50
OJ350300	3.5 × 30	200	OJ500606	5.0 × 60	200	OJ601501	6.0 × 150	50
OJ400203	4.0 × 20	200	OJ500705	5.0 × 70	200	OJ272252	6.0 × 180	25
OJ400258	4.0 × 25	200	OJ500804	5.0 × 80	200	OJ272269	6.0 × 200	25
OJ400302	4.0 × 30	200	OJ500903	5.0 × 90	100			
OJ400401	4.0 × 40	200	OJ501009	5.0 × 100	100			

Ulti-Mate Woodscrews

Zinc and Clear Passivated

Product Codes Begin **9ULTIMATE** Product Group **5062**

BBZ350201	3.5 × 20	200	BBZ400401	4.0 × 40	200
BBZ350256	3.5 × 25	200	BBZ400500	4.0 × 50	200
BBZ350300	3.5 × 30	200	BBZ500507	5.0 × 50	200
BBZ400258	4.0 × 25	200	BBZ500705	5.0 × 70	200
BBZ400302	4.0 × 30	200	BBZ601006	5.0 × 100	100



Ulti-Mate[®] Drywall Screws

A GENUINE PRODUCT OF THE PHILLIPS SCREW COMPANY



Product Codes Begin **9ULTIMATE** Product Group **5062**

Article No.	Size	Box Qty.
OJ578590	3.5 x 25	1000
OJ578606	3.5 x 32	1000
OJ578613	3.5 x 38	1000
OJ578620	3.5 x 42	1000
OJ578637	3.5 x 50	1000
OJ578644	3.5 x 60	500
OJ578651	4.2 x 75	500

- STICK-FIT[™] CUTS OUT WASTE - NO MORE DROPPED SCREWS.
- STICK-FIT[™] RECESS ENABLES OPERATOR TO FIX WITH ONE HAND, LEAVING OTHER HAND FREE TO POSITION BOARD.
- SUITABLE FOR BOTH TIMBER AND STEEL STUDS.
- BLACK PHOSPHATE COATED. SCREWS CLEANED DURING MANUFACTURE TO REMOVE SHARP SWarf.

Ulti-Mate Cases and Assortments

Product Codes Begin **9ULTIMATE** Product Group **5062**

ULTASS	Ultimate Pack 1000 Boxed Screws	A
A244304	Ultimate Plastic Box 700 Screws	B
A221688	Ultimate Plastic Case 1610 Screws	C
A244298	Ultimate Metal Case 1570 Screws	D



Ulti-Mate Tubs

Product Codes Begin **9ULTIMATE** Product Group **5062**



OJ582429	4.0 x 30 Ultimate Screws Tub Of 1000
OJ582436	4.0 x 40 Ultimate Screws Tub Of 1000
OJ582443	4.0 x 50 Ultimate Screws Tub Of 1000
OJ582450	4.0 x 70 Ultimate Screws Tub Of 1000

Twinwik Woodscrews

BZP Countersunk Head Recessed Hardened Steel Twinthread

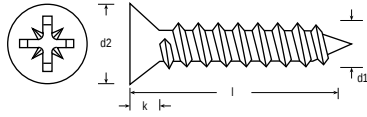

	d1	No. 4	No. 5	No. 6	No. 7	No. 8	No. 10	No. 12
d2	max.	5.49	6.20	6.91	7.62	8.33	9.75	11.18
d1	max.	2.87	3.23	3.58	3.94	4.29	5.00	5.72
k	max.	1.63	1.85	2.08	2.31	2.54	2.97	3.43
Recess No.		1	2	2	2	2	2	3

Boxed

Product Codes Begin **9TQTQCSKPZ** Product Group **5004**

Article No.	Size	Box Qty.	Article No.	Size	Box Qty.	Article No.	Size	Box Qty.
OJ077857	4 × 1/2	200	OJ446905	8 × 1/2	200	OJ078113	10 × 2	200
OJ077871	4 × 5/8	200	OJ077895	8 × 5/8	200	OJ446936	10 × 2.1/4	200
OJ077901	4 × 3/4	200	OJ077925	8 × 3/4	200	OJ078144	10 × 2.1/2	100
OJ077932	4 × 1	200	OJ077963	8 × 1	200	OJ078175	10 × 3	100
OJ077864	6 × 1/2	200	OJ078007	8 × 1.1/4	200	OJ081403	10 × 3.1/2	100
OJ077888	6 × 5/8	200	OJ078045	8 × 1.1/2	200	OJ081427	10 × 4	100
OJ077918	6 × 3/4	200	OJ078076	8 × 1.3/4	200	OJ021355	12 × 1	200
OJ077949	6 × 1	200	OJ078106	8 × 2	200	OJ078021	12 × 1.1/4	200
OJ077987	6 × 1.1/4	200	OJ446912	8 × 2.1/4	200	OJ078069	12 × 1.1/2	200
OJ078038	6 × 1.1/2	200	OJ078137	8 × 2.1/2	200	OJ011059	12 × 1.3/4	100
OJ011028	6 × 1.3/4	200	OJ078168	8 × 3	100	OJ078120	12 × 2	100
OJ078090	6 × 2	200	OJ446929	10 × 3/4	200	OJ078151	12 × 2.1/2	100
OJ422572	7 × 3/4	200	OJ077970	10 × 1	200	OJ078182	12 × 3	100
OJ077956	7 × 1	200	OJ078014	10 × 1.1/4	200	OJ081410	12 × 3.1/2	100
OJ077994	7 × 1.1/4	200	OJ078052	10 × 1.1/2	200	OJ081434	12 × 4	100
OJ446899	7 × 1.1/2	200	OJ078083	10 × 1.3/4	200			

Pre-packed Clams

Product Codes Begin **UCTQCSKPZ** Product Group **5033**

UC4710	6 × 5/8	200	UC4740	8 × 2	200	UC4770	10 × 3	100
UC4730	8 × 11/4	200	UC4745	8 × 3	200	UC4775	10 × 4	100
UC4735	8 × 11/2	200	UC4765	10 × 2	200	UC4785	12 × 4	100

BZP Round Head Recessed Hardened Steel Twinthread

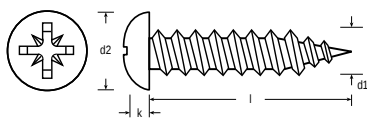

	d1	No. 4	No. 6	No. 8	No. 10
d2	max.	5.46	6.78	8.10	9.45
d1	max.	2.87	3.58	4.29	5.00
k	max.	2.06	2.54	3.00	3.45
Recess No.		1	2	2	2

Product Codes Begin **9TQTQRNDPZ** Product Group **5004**

Article No.	Size	Box Qty.	Article No.	Size	Box Qty.	Article No.	Size	Box Qty.			
OJ774190	4 × 1/2	200	OJ011073	6 × 1.1/4	200	OJ421483	8 × 1	200	OJ421605	10 × 1.1/4	200
OJ421261	6 × 1/2	200	OJ011080	6 × 1.1/2	200	OJ421513	8 × 1.1/4	200	OJ421636	10 × 1.1/2	200
OJ421346	6 × 5/8	200	OJ774206	8 × 1/2	200	OJ421544	8 × 1.1/2	200	OJ421667	10 × 2	200
OJ421391	6 × 3/4	200	OJ774213	8 × 5/8	200	OJ774220	8 × 2	200	OJ774237	10 × 2.1/2	100
OJ421421	6 × 1	200	OJ421452	8 × 3/4	200	OJ421575	10 × 1	200	OJ011097	10 × 3	100



General Purpose Woodscrews

ZYP & Waxed Countersunk Head Recessed Hardened Steel Single Thread

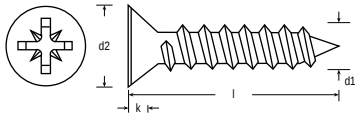

	d1	3	3.5	4	4.5	5	6
d2	max.	6.00	7.00	8.00	9.00	10.00	12.00
k	max.	1.95	2.30	2.60	2.95	3.26	3.80
Recess	min.	1.76	1.60	2.05	2.64	2.89	3.00
Penetration	max.	2.01	2.06	2.51	3.10	3.35	3.45
Recess	No.	1	2	2	2	2	3

Boxed

Product Codes Begin **9CHIPPY** Product Group **5102**

Article No.	Size	Box Qty.	Article No.	Size	Box Qty.	Article No.	Size	Box Qty.
OJ491950	3.0 × 12	200	OJ492247	4.0 × 60	CEE 100	OJ492414	5.0 × 60	CEE 100
OJ491967	3.0 × 16	200	OJ492254	4.0 × 70	CEE 100	OJ492421	5.0 × 70	CEE 100
OJ491974	3.0 × 20	200	OJ394350	4.5 × 15	200	OJ492438	5.0 × 75	CEE 100
OJ491981	3.0 × 25	200	OJ411910	4.5 × 20	CEE 200	OJ492445	5.0 × 80	CEE 100
OJ411866	3.0 × 30	200	OJ492261	4.5 × 25	CEE 200	OJ492452	5.0 × 90	100
OJ491998	3.5 × 12	200	OJ492278	4.5 × 30	CEE 200	OJ492469	5.0 × 100	CEE 100
OJ492001	3.5 × 16	200	OJ492285	4.5 × 35	CEE 200	OJ492476	6.0 × 40	CEE 200
OJ492018	3.5 × 20	200	OJ492292	4.5 × 40	CEE 200	OJ492483	6.0 × 50	CEE 100
OJ492025	3.5 × 25	200	OJ492308	4.5 × 45	CEE 200	OJ492490	6.0 × 60	CEE 100
OJ492032	3.5 × 30	200	OJ492315	4.5 × 50	CEE 200	OJ492506	6.0 × 70	CEE 100
OJ411873	3.5 × 35	200	OJ492322	4.5 × 60	CEE 100	OJ492513	6.0 × 75	CEE 100
OJ492049	3.5 × 40	200	OJ492339	4.5 × 70	CEE 100	OJ492520	6.0 × 80	CEE 100
OJ411880	3.5 × 45	200	OJ492346	4.5 × 75	CEE 100	OJ492537	6.0 × 90	CEE 100
OJ011103	3.5 × 50	200	OJ411927	4.5 × 80	CEE 100	OJ492544	6.0 × 100	CEE 100
OJ492056	4.0 × 16	200	OJ411934	5.0 × 20	200	OJ492551	6.0 × 110	CEE 100
OJ492063	4.0 × 20	CEE 200	OJ492353	5.0 × 25	CEE 200	OJ411941	6.0 × 120	CEE 50
OJ492070	4.0 × 25	CEE 200	OJ492360	5.0 × 30	CEE 200	OJ492568	6.0 × 130	CEE 50
OJ492087	4.0 × 30	CEE 200	OJ492377	5.0 × 35	CEE 200	OJ492575	6.0 × 150	CEE 50
OJ492094	4.0 × 35	CEE 200	OJ492384	5.0 × 40	CEE 200	OJ411958	6.0 × 180	CEE 50
OJ492100	4.0 × 40	CEE 200	OJ492391	5.0 × 45	CEE 200	OJ411965	6.0 × 200	CEE 50
OJ492223	4.0 × 45	CEE 200	OJ492407	5.0 × 50	CEE 200			
OJ492230	4.0 × 50	CEE 200	OJ011110	5.0 × 55	CEE 200			

Pre-packed Clams

Product Codes Begin **UCCHIPPY** Product Group **5033**

UC4100	3.0 × 12	200	UC4150	4.0 × 60	CEE 200	UC4200	6.0 × 130	CEE 50
UC4105	3.5 × 16	200	UC4155	4.0 × 70	CEE 200	UC4205	6.0 × 150	CEE 50
UC4110	3.5 × 20	200	UC4160	5.0 × 50	CEE 200	UC4220	4.0 × 40	CEE 2000
UC4115	3.5 × 25	200	UC4165	5.0 × 60	CEE 100	UC4225	4.0 × 50	CEE 1600
UC4120	3.5 × 30	200	UC4170	5.0 × 70	CEE 100	UC4230	4.0 × 70	CEE 1200
UC4125	4.0 × 25	CEE 200	UC4175	5.0 × 80	CEE 100	UC4235	5.0 × 50	CEE 1000
UC4130	4.0 × 30	CEE 200	UC4180	5.0 × 100	CEE 100	UC4240	5.0 × 70	CEE 1000
UC4135	4.0 × 35	CEE 200	UC4185	6.0 × 70	CEE 100	UC4245	5.0 × 80	CEE 900
UC4140	4.0 × 40	CEE 200	UC4190	6.0 × 90	CEE 100	UC4250	5.0 × 100	CEE 700
UC4145	4.0 × 50	CEE 200	UC4195	6.0 × 100	CEE 100	UC4255	6.0 × 100	CEE 600

Stainless Steel Countersunk Head Recessed Single Thread

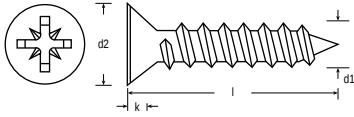

	d1	3.5	4	4.5	5	6
d2	max.	7.00	8.00	9.00	10.00	12.00
k	max.	2.30	2.60	2.95	3.26	3.80
Recess	min.	1.60	2.05	2.64	2.89	3.00
Penetration	max.	2.06	2.51	3.10	3.35	3.45
Recess	No.	2	2	2	2	3

Boxed

Product Codes Begin **9STSTCHIPPY** Product Group **5105**

Article No.	Size	Box Qty.	Article No.	Size	Box Qty.	Article No.	Size	Box Qty.
OJ239941	3.5 × 20	200	OJ240015	4.0 × 50	€€ 100	OJ240084	5.0 × 100	€€ 50
OJ239958	3.5 × 25	200	OJ240022	4.0 × 70	€€ 100	OJ240091	6.0 × 40	€€ 50
OJ239965	3.5 × 30	200	OJ240039	5.0 × 30	€€ 100	OJ240107	6.0 × 50	€€ 50
OJ239972	4.0 × 25	€€ 200	OJ240046	5.0 × 40	€€ 100	OJ240114	6.0 × 60	€€ 50
OJ239989	4.0 × 30	€€ 200	OJ240053	5.0 × 50	€€ 100	OJ240121	6.0 × 80	€€ 50
OJ239996	4.0 × 35	€€ 200	OJ240060	5.0 × 60	€€ 100	OJ240138	6.0 × 100	€€ 50
OJ240008	4.0 × 40	€€ 200	OJ240077	5.0 × 70	€€ 100			

Pre-packed Clams

Product Codes Begin **UCSSCHIP** Product Group **5033**

UC4610	4.0 × 30	200	UC4620	4.0 × 50	200	UC4630	5.0 × 50	200
UC4615	4.0 × 40	200	UC4625	5.0 × 40	200	UC4635	5.0 × 70	100

Slotted Woodscrews

Black Japanned Round Head

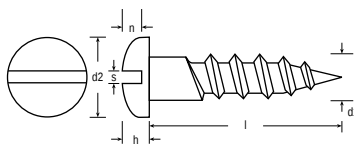
Product Codes Begin **9TQJRNSWS** Product Group **5006**

Article No.	Size	Box Qty.	Article No.	Size	Box Qty.	Article No.	Size	Box Qty.
OJ067247	4 × 1/2	200	OJ067339	8 × 1	200	OJ067407	10 × 1.1/2	200
OJ067254	6 × 1/2	200	OJ067360	8 × 1.1/4	200	OJ067438	10 × 2	200
OJ067292	6 × 3/4	200	OJ067391	8 × 1.1/2	200	OJ010946	10 × 2.1/2	100
OJ067322	6 × 1	200	OJ067421	8 × 2	200	OJ067414	12 × 1.1/2	200
OJ067353	6 × 1.1/4	200	OJ067315	10 × 3/4	200	OJ067445	12 × 2	100
OJ067384	6 × 1.1/2	200	OJ067346	10 × 1	200			
OJ067308	8 × 3/4	200	OJ067377	10 × 1.1/4	200			



Brass Countersunk Head

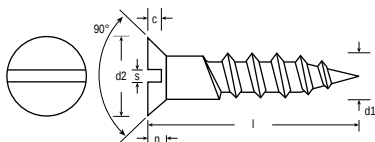

Product Codes Begin **9TQCSKBWS** Product Group **5006**

Article No.	Size	Box Qty.						
OJ066370	2 × 3/8	200	OJ066578	6 × 1	200	OJ066608	10 × 1	200
OJ066400	2 × 1/2	200	OJ066615	6 × 1.1/4	200	OJ066646	10 × 1.1/4	200
OJ066387	3 × 3/8	200	OJ066660	6 × 1.1/2	200	OJ066684	10 × 1.1/2	200
OJ066417	3 × 1/2	200	OJ066547	7 × 3/4	200	OJ066714	10 × 1.3/4	200
OJ066462	3 × 5/8	200	OJ066585	7 × 1	200	OJ066745	10 × 2	100
OJ066813	4 × 3/8	200	OJ066622	7 × 1.1/4	200	OJ066776	10 × 2.1/2	100
OJ066424	4 × 1/2	200	OJ066455	8 × 1/2	200	OJ066790	10 × 3	100
OJ066479	4 × 5/8	200	OJ066554	8 × 3/4	200	OJ066653	12 × 1.1/4	200
OJ066516	4 × 3/4	200	OJ066592	8 × 1	200	OJ066691	12 × 1.1/2	200
OJ066561	4 × 1	200	OJ066639	8 × 1.1/4	200	OJ066752	12 × 2	100
OJ066486	5 × 5/8	200	OJ066677	8 × 1.1/2	200	OJ066783	12 × 2.1/2	100
OJ066523	5 × 3/4	200	OJ066707	8 × 1.3/4	200	OJ066806	12 × 3	100
OJ066448	6 × 1/2	200	OJ066738	8 × 2	200	OJ283579	12 × 4	50
OJ066493	6 × 5/8	200	OJ066769	8 × 2.1/2	100			
OJ066530	6 × 3/4	200	OJ010953	8 × 3	100			

Brass Round Head

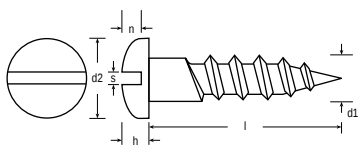

Product Codes Begin **9TQRNDBWS** Product Group **5006**

Article No.	Size	Box Qty.						
OJ066974	2 × 3/8	200	OJ067063	6 × 5/8	200	OJ067223	8 × 2	200
OJ067001	2 × 1/2	200	OJ067087	6 × 3/4	200	OJ010977	8 × 2.1/2	100
OJ066981	3 × 3/8	200	OJ067117	6 × 1	200	OJ067131	10 × 1	200
OJ067018	3 × 1/2	200	OJ067148	6 × 1.1/4	200	OJ067162	10 × 1.1/4	200
OJ066998	4 × 3/8	200	OJ067179	6 × 1.1/2	200	OJ067193	10 × 1.1/2	200
OJ067025	4 × 1/2	200	OJ067094	8 × 3/4	200	OJ067230	10 × 2	100
OJ067056	4 × 5/8	200	OJ067124	8 × 1	200	OJ010984	10 × 2.1/2	100
OJ067070	4 × 3/4	200	OJ067155	8 × 1.1/4	200	OJ067209	12 × 1.1/2	200
OJ067100	4 × 1	200	OJ067186	8 × 1.1/2	200			
OJ067032	6 × 1/2	200	OJ010960	8 × 1.3/4	200			

Brass Raised Head

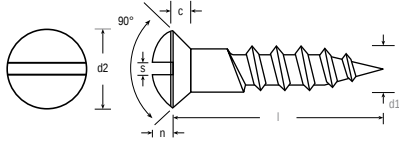

Product Codes Begin **9TQR**SDBWS Product Group **5006**

Article No.	Size	Box Qty.						
OJ085883	4 × 1/2	200	OJ085951	6 × 1	200	OJ086002	8 × 1.1/4	200
OJ085890	4 × 5/8	200	OJ085968	6 × 1.1/4	200	OJ086019	8 × 1.1/2	200
OJ085906	4 × 3/4	200	OJ085975	6 × 1.1/2	200	OJ086026	8 × 2	200
OJ085937	6 × 5/8	200	OJ085982	8 × 3/4	200			
OJ085944	6 × 3/4	200	OJ085999	8 × 1	200			

Anti Vandal Screws

BZP Clutch Head Hardened Steel

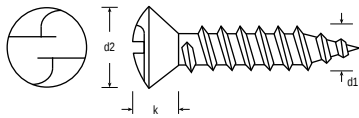

Gauge	6	8	10	12
d1 max.	2.50	2.92	3.35	3.83
d1 min.	2.40	2.79	3.22	3.70
d2 max.	7.35	7.86	8.86	10.36
d2 min.	7.00	7.50	8.50	10.00
k max.	2.20	2.50	2.90	3.50

Product Codes Begin **9TQCLUTCH** Product Group **5006**

OJ074801	8 × 3/4	200	OJ074832	10 × 1.1/4	200
OJ074818	8 × 1	200	OJ074849	10 × 1.1/2	200
OJ074825	8 × 1.1/4	200	OJ074856	12 × 2	100

Carcass Screws

Black Oxide Countersunk Head Recessed

A specially deep and spaced thread, on a thin shank, suitable for quick assembly chipboard furniture

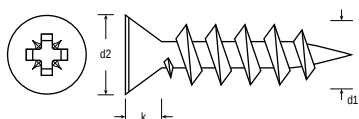

Gauge	8
d1	4.37
d2	7.62
k	2.21

Product Codes Begin **9TQCARCASS** Product Group **5006**

OJ287133	8 × 1.3/4	500
----------	-----------	-----



Brass Screw Cup

Self Colour Brass Turned Pattern

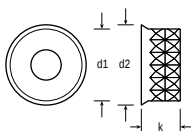

Gauge	6g	8g	10g	12g
d1 dia.	8.40	8.70	10.00	11.00
d2 dia.	8.80	10.30	11.80	13.10
k	4.50	4.80	5.40	5.70

Product Codes Begin **9TQBTURN** Product Group **5006**

Article No.	Screw Gauge	Box Qty.	Article No.	Screw Gauge	Box Qty.
OJ079615	6	200	OJ079639	10	200
OJ079622	8	200	OJ079646	12	200

Self Colour Brass Surface Pattern

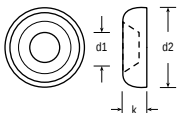

Gauge	4-5g	6g	7-8g	9-10g	11-12g	14g
d1 dia.	5.87	7.29	8.79	10.29	11.29	13.31
d2 dia.	7.80	9.80	11.73	13.64	15.52	17.50
k	1.27	1.73	2.00	2.29	2.54	2.79
t	0.30	0.30	0.30	0.30	0.30	0.30

Product Codes Begin **9TQBSURFSCU** Product Group **5006**

Article No.	Screw Gauge	Box Qty.	Article No.	Screw Gauge	Box Qty.
OJ079714	4-5	500	OJ079677	9-10	500
OJ079653	6	500	OJ079608	11-12	500
OJ079660	7-8	500			

NP Brass Surface Pattern

Product Codes Begin **9TQNPSURFSCU** Product Group **5006**

OJ079578	6	500	OJ079707	11-12	500
OJ079585	7-8	500	OJ021089	14	500
OJ079691	9-10	500			

Domecaps

Two piece cap and washer for Countersunk screws

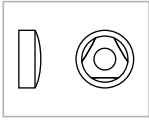

Product Codes Begin **9TQDOMETOP** Product Group **5006**

Article No.	Colour	Box Qty.	Article No.	Colour	Box Qty.
OJ582092	Black	200	OJ582122	Light Brown	200
OJ582108	CP	200	OJ582139	Dark Brown	200
OJ582115	White	200			

Plustops

One piece, push in cap for recessed screws

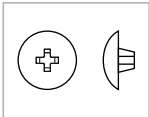

Product Codes Begin **9TQPLUSTOP** Product Group **5006**

OJ582016	Black	1000	OJ582030	Light Brown	1000
OJ582023	White	1000			



Decking/Exterior Screws

Green Organic Coated Countersunk Head Recessed

Green organic coating gives a minimum of 1,200 hours salt spray resistance and is recommended as compatible for treated timbers. Ideal for most external applications.

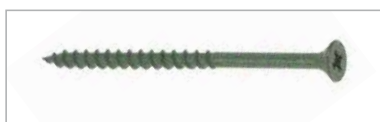

Small Box

Product Codes Begin **9DEC** Product Group **5178**

Article No.	Size	Box Qty.			
OJ199122	8 × 1.1/2	200	OJ199139	8 × 3	100
OJ511702	8 × 2	200	OJ511726	10 × 3	100
OJ511771	8 × 2.1/2	150			

Clam

UC4410	8 × 2	200	UC4420	8 × 3	100
UC4415	8 × 2.1/2	150	UC4425	10 × 3	100

Tub

OJ199146	8 × 1.1/2	500	OJ199153	8 × 3	200
OJ526485	8 × 2	500	OJ526508	10 × 3	200
OJ526492	8 × 2.1/2	350			

Trade Tub

OJ277660	8 × 2	1200	UC4435	8 × 2.1/2	1000
UC4430	8 × 2	1000	UC444	8 × 3	1000
OJ277677	8 × 2.1/2	1100			

Mirror Screws

CP Dome Top with BZP Screws

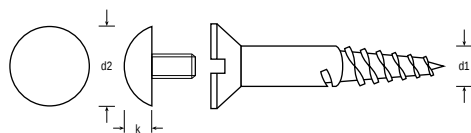

Gauge	8
d1 max.	4.29
d1 min.	4.04
d2 max.	8.33
d2 min.	7.92
k	2.54

Product Codes Begin **9TQCPDTSWS** Product Group **5006**

Article No.	Size	Box Qty.			
OJ087696	8 × 3/4	100	OJ087719	8 × 1.1/4	100
OJ087702	8 × 1	100	OJ087726	8 × 1.1/2	100

CP Dome Top with Brass Screws

OJ014128	8 × 3/4	200	OJ014173	8 × 1.1/2	200
OJ014135	8 × 1	200	OJ014197	8 × 2	200
OJ014159	8 × 1.1/4	200			

Product Codes Begin **9CPDTBWS** Product Group **5005**

CE Approved Coach Screws

BZP Hexagon Head DIN 571

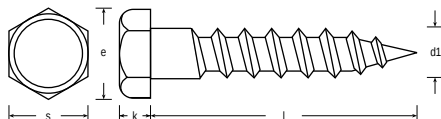

d1	6mm	8mm	10mm	12mm
k	4	5.5	7	8
s	10	13	17	19
e min.	10.89	14.2	18.72	20.88

Product Codes Begin **AHXC** Product Group **8**

Article No.	Size	Box Qty.									
OJ480176	6.0 × 20mm	200									
OJ480183	6.0 × 25mm	CE	200	OJ003207	8.0 × 70mm	CE	100	OJ480435	10.0 × 130mm	CE	25
OJ480190	6.0 × 30mm	CE	200	OJ480305	8.0 × 75mm	CE	100	OJ003290	10.0 × 140mm	CE	25
OJ480206	6.0 × 40mm	CE	200	OJ003214	8.0 × 80mm	CE	100	OJ480442	10.0 × 150mm	CE	25
OJ003092	6.0 × 45mm	CE	200	OJ480312	8.0 × 90mm	CE	100	OJ003306	10.0 × 160mm	CE	25
OJ480213	6.0 × 50mm	CE	200	OJ480329	8.0 × 100mm	CE	50	OJ003313	10.0 × 180mm	CE	25
OJ003108	6.0 × 60mm	CE	200	OJ480336	8.0 × 110mm	CE	50	OJ003320	10.0 × 200mm	CE	25
OJ480220	6.0 × 65mm	CE	200	OJ003221	8.0 × 120mm	CE	50	OJ003337	12.0 × 40mm	CE	50
OJ003115	6.0 × 70mm	CE	200	OJ480343	8.0 × 130mm	CE	50	OJ480459	12.0 × 50mm	CE	50
OJ480237	6.0 × 75mm	CE	200	OJ003238	8.0 × 140mm	CE	50	OJ003344	12.0 × 60mm	CE	50
OJ003122	6.0 × 80mm	CE	100	OJ480350	8.0 × 150mm	CE	50	OJ480466	12.0 × 65mm	CE	50
OJ480244	6.0 × 90mm	CE	100	OJ003245	10.0 × 30mm	CE	100	OJ003351	12.0 × 70mm	CE	25
OJ480251	6.0 × 100mm	CE	100	OJ480367	10.0 × 40mm	CE	100	OJ480473	12.0 × 75mm	CE	25
OJ003153	8.0 × 25mm	CE	200	OJ480374	10.0 × 50mm	CE	100	OJ003368	12.0 × 80mm	CE	25
OJ480268	8.0 × 30mm	CE	200	OJ003252	10.0 × 60mm	CE	50	OJ480480	12.0 × 90mm	CE	25
OJ003160	8.0 × 35mm	CE	200	OJ480381	10.0 × 65mm	CE	50	OJ480497	12.0 × 100mm	CE	50
OJ480275	8.0 × 40mm	CE	200	OJ003269	10.0 × 70mm	CE	50	OJ003375	12.0 × 120mm	CE	25
OJ003177	8.0 × 45mm	CE	100	OJ480398	10.0 × 75mm	CE	50	OJ480510	12.0 × 130mm	CE	25
OJ480282	8.0 × 50mm	CE	200	OJ003276	10.0 × 80mm	CE	50	OJ003382	12.0 × 140mm	CE	25
OJ480284	8.0 × 55mm	CE	100	OJ480404	10.0 × 90mm	CE	50	OJ480527	12.0 × 150mm	CE	25
OJ003191	8.0 × 60mm	CE	100	OJ480411	10.0 × 100mm	CE	50	OJ003399	12.0 × 160mm	CE	25
OJ480299	8.0 × 65mm	CE	100	OJ480428	10.0 × 110mm	CE	50	OJ480534	12.0 × 180mm	CE	25
				OJ003283	10.0 × 120mm	CE	25	OJ480541	12.0 × 200mm	CE	25

UNIFIX[®]

Trade • Retail



Trade Bag: The Unifix branded trade bag range covers popular products and sizes from a wide selection of fasteners and fixings. The packaging is robust, re-sealable, drop-proof, water resistant, easy to identify, and an ideal size to carry.

Retail: The Unifix branded retail range follows a similar offering to the trade bag range, conveniently packed in small pack quantities.

See pages 253-290 for the product range

TIMBERDRIVE

CE approved for structural applications
Green Organic Coated

Clam Pack

Product Codes Begin **TDS** Product Group **5184**

Article No.	Size	CE	Pack Qty.	Article No.	Size	CE	Pack Qty.
OJ171524G	7 × 75mm	CE	10 × 25	OJ171548G	7 × 150mm	CE	10 × 25
OJ519425	7 × 90mm	CE	10 × 25	OJ171555G	7 × 200mm	CE	10 × 10
OJ171531G	7 × 100mm	CE	10 × 25	OJ171562G	7 × 250mm	CE	10 × 10

Box

Product Codes Begin **TDS** Product Group **5184**

OJ495286	7 × 75mm	CE	50	OJ495309	7 × 150mm	CE	50
OJ519432	7 × 90mm	CE	50	OJ495316	7 × 200mm	CE	50
OJ495293	7 × 100mm	CE	50				

- Heavy duty timber fixings
- Hexagon head for high torque entry
- Under head ribbing for easy self countersinking
- Heat treated shank for strength
- Easy entry thread design
- Organic coating for greater weather resistance and lubricated to reduce friction
- Gimlet point requires no pre-drilling
- Includes free hexagon driver bit in every pack





Twistec Screws CE Marked

Countersunk Head

A CE approved heavy duty fixing for both timber-to-timber and component-to-timber applications. It has been specifically designed for ease of use and speed of application when used with a power tool.

Product Codes Begin **TTS** Product Group **5185**

Article No.	Size	Finish	Box Qty.
903550	8.0×80	CE	ZYP 50
903551	8.0×100	CE	ZYP 50
902920	8.0×120	CE	ZYP 50
902919	8.0×140	CE	ZYP 50
902921	8.0×160	CE	ZYP 50
902922	8.0×180	CE	ZYP 50
902923	8.0×200	CE	ZYP 50
902924	8.0×220	CE	ZYP 50
902925	8.0×240	CE	ZYP 50
902926	8.0×260	CE	ZYP 50
902927	8.0×280	CE	ZYP 50

902928	8.0×300	CE	ZYP 50
903513	10.0×100	CE	ZYP 50
903491	10.0×120	CE	ZYP 50
903492	10.0×140	CE	ZYP 50
903493	10.0×160	CE	ZYP 50
903494	10.0×180	CE	ZYP 50
903495	10.0×200	CE	ZYP 50
903496	10.0×220	CE	ZYP 50
903497	10.0×240	CE	ZYP 50
903498	10.0×260	CE	ZYP 50
903500	10.0×300	CE	ZYP 50

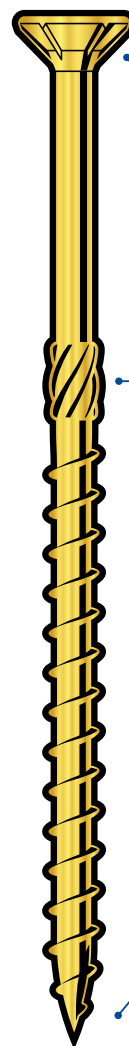

Head styles available
Countersunk and flange

Under-head ribbing
Self countersinking

Robust thread
Designed for easy penetration whilst offering maximum pull out strength

Type U thread
Prevents shank from binding

Bright zinc, and zinc & yellow plating
Weather resistant, and ideal for treated timbers

Heat treated shank
Ensures maximum strength

Self drilling point
Eliminates the need for pre-drilling



Torx drive
For ease of use and speed with power drills

Flange Head

Product Codes Begin **TTS** Product Group **5185**

945717	6.0×80	CE	BZP 100
945719	6.0×100	CE	BZP 100
945721	6.0×120	CE	BZP 100
945723	6.0×140	CE	BZP 100
945725	6.0×160	CE	BZP 100
945726	6.0×180	CE	BZP 100
945727	6.0×200	CE	BZP 100
G903204	8.0×80	CE	ZYP 50
G903205	8.0×100	CE	ZYP 50
G903466	8.0×120	CE	ZYP 50
G903467	8.0×140	CE	ZYP 50
G903468	8.0×160	CE	ZYP 50
G903469	8.0×180	CE	ZYP 50
G903470	8.0×200	CE	ZYP 50
G903471	8.0×220	CE	ZYP 50

G903472	8.0×240	CE	ZYP 50
G903473	8.0×260	CE	ZYP 50
G903474	8.0×280	CE	ZYP 50
G903475	8.0×300	CE	ZYP 50
945752	10.0×120	CE	BZP 50
945753	10.0×140	CE	BZP 50
945754	10.0×160	CE	BZP 50
945755	10.0×180	CE	BZP 50
945756	10.0×200	CE	BZP 50
945757	10.0×220	CE	BZP 50
945758	10.0×240	CE	BZP 50
945759	10.0×260	CE	BZP 50
945760	10.0×280	CE	BZP 50
945761	10.0×300	CE	BZP 50

Drywall Screws CE Approved 48hr Salt Spray Tested

ZYP Bugle Head Sharp Point

Fine thread, suitable for fixing plasterboard and drywall to light steel track and wood

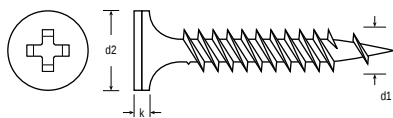

Gauge	3.5	4.2	4.8
d2	8.40	8.40	8.40
d1 max.	3.60	4.30	4.95
d1 min.	3.40	4.05	4.70
k min.	2.40	3.10	3.8
Recess No.	2	2	2

Box

Product Codes Begin **9TQDBZBUG** Product Group **5156**

Article No.	Size	Box Qty.	Article No.	Size	Box Qty.	Article No.	Size	Box Qty.	Article No.	Size	Box Qty.
OJ372730	3.5 × 25	CE 1000	OJ372792	3.5 × 42	CE 1000	OJ022086	3.5 × 55	CE 1000	OJ239545	4.2 × 75	CE 500
OJ372754	3.5 × 32	CE 1000	OJ223186	3.5 × 45	CE 1000	OJ419121	3.5 × 60	CE 500			
OJ372778	3.5 × 38	CE 1000	OJ414874	3.5 × 50	CE 1000	OJ239538	4.2 × 65	CE 500			

Small Box

Product Codes Begin **9TQDRYWALL** Product Group **5012**

OJ201702	3.5 × 25	CE 200	OJ201719	3.5 × 38	CE 200	OJ201740	3.5 × 50	CE 200
OJ201726	3.5 × 32	CE 200	OJ201733	3.5 × 42	CE 200			

Black Phosphate Bugle Head Sharp Point

Fine thread, suitable for fixing plasterboard and drywall to light steel track and wood

Box

Product Codes Begin **9TQDBLBUG** Product Group **5156**

OJ037486	3.5 × 25	CE 1000	OJ037509	3.5 × 38	CE 1000	OJ037516	3.5 × 50	CE 1000	OJ239507	4.2 × 65	CE 500
OJ037493	3.5 × 32	CE 1000	OJ071459	3.5 × 42	CE 1000	OJ239590	3.5 × 55	CE 1000	OJ239514	4.2 × 75	CE 500
V60113	3.5 × 35	CE 1000	OJ237954	3.5 × 45	CE 1000	OJ239606	3.5 × 60	CE 500	OJ239521	4.8 × 100	CE 200

Small Box

Product Codes Begin **9TQDRYWALL** Product Group **5012**

OJ119199	3.5 × 25	CE 200	OJ119212	3.5 × 38	CE 200	OJ119236	3.5 × 50	CE 200	OJ119267	4.2 × 75	CE 200
OJ119205	3.5 × 32	CE 200	OJ119229	3.5 × 42	CE 200	OJ119243	3.5 × 60	CE 200			

Black Phosphate Bugle Head Sharp Point

Coarse thread, suitable for fixing plasterboard and drywall to wood

Box

Product Codes Begin **9TQDBLBUGC** Product Group **5156**

OJ364131	3.5 × 32	CE 1000	OJ569178	3.5 × 42	CE 1000
OJ364148	3.5 × 38	CE 1000	OJ569185	3.5 × 50	CE 1000



Drywall Screws CE Approved 48hr Salt Spray Tested

ZYP Wafer Head Sharp Point

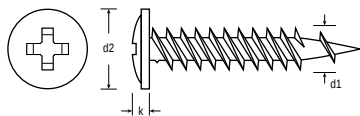

Gauge	4.2
d2	10.90
d1	3.60
k	2.55
Recess No.	2

Product Codes Begin **9TQDBZWAF** Product Group **5156**

OJ498478	4.2 × 14	CE	1000
----------	----------	----	------

ZYP Wafer Head Self Drilling

Self drilling drywall screw for light partition up to 2.5mm

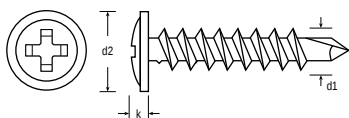

Gauge	4.2	
d2	10.90	
d1	3.60	
k	max.	2.55
Recess No.	2	

Product Codes Begin **9TQDBZWAF** Product Group **5156**

Article No.	Size	CE	Box Qty.
OJ223193	4.2 × 13	CE	1000

ZYP Pan Head Self Drilling

Self drilling drywall screw for light partition up to 2.5mm

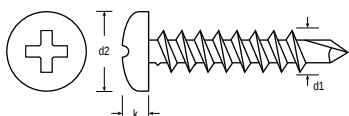

Gauge	3.5	3.9	4.2
d2	6.90	7.50	8.20
d1	max.	3.10	3.60
d1	min.	2.80	2.90
k	min.	2	2

Product Codes Begin **9TQSDPAN** Product Group **5156**

OJ285849	3.5 × 16	CE	1000
OJ285863	3.5 × 32	CE	1000

OJ285887	3.9 × 11	CE	1000
----------	----------	----	------

ZYP Bugle Head Self Drilling

Self drilling drywall screw for light partition up to 2.5mm

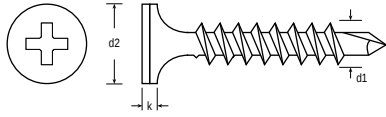

Gauge	3.5	4.2
d2	7.90	8.62
d1	2.95	3.10
k	2.40	3.10
Recess No.	2	2

Product Codes Begin **9TQDSDBUG** Product Group **5156**

OJ285917	3.5 × 25	€€	1000	OJ285955	3.5 × 50	€€	1000
OJ285924	3.5 × 32	€€	1000	OJ239552	4.2 × 65	€€	500
OJ285931	3.5 × 38	€€	1000	OJ239583	4.2 × 75	€€	500
OJ285948	3.5 × 42	€€	1000				

Collated Drywall Screws

Black Phosphate Bugle Head Case Hardened
Cross Recessed Fine Thread Sharp Point

Collated in strips, suitable for most makes of gun

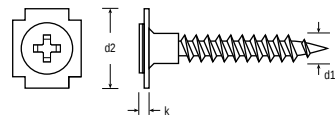

Gauge	3.5	4.2	4.8
d2	8.40	8.40	8.40
d1 max.	3.60	4.30	4.95
d1 min.	3.40	4.05	4.70
k min.	2.40	3.10	3.8
Recess No.	2	2	2

Product Codes Begin **9TQCDBLBUG** Product Group **5156**

Article No.	Size	Box Qty.					
OJ128962	3.5 × 25	€€	1000	OJ128993	3.5 × 42	€€	1000
OJ128979	3.5 × 32	€€	1000	OJ158365	3.5 × 45	€€	1000
OJ158358	3.5 × 35	€€	1000	OJ129006	3.5 × 50	€€	1000
OJ128986	3.5 × 38	€€	1000	OJ129013	3.5 × 55	€€	1000
				OJ281865	3.9 × 45	€€	1000
				OJ281872	3.9 × 55	€€	1000

Black Phosphated Bugle Head Case Hardened
Cross Recessed Coarse Thread Sharp Point

Collated in strips, suitable for most makes of gun. Coarse thread for timber frames.

Product Codes Begin **9TQCDBLBUG** Product Group **5156**

OJ180557	3.5 × 25	€€	1000	OJ263687	3.9 × 38	€€	1000
OJ180564	3.5 × 35	€€	1000	OJ214702	3.9 × 45	€€	1000
OJ214696	3.9 × 35	€€	1000	OJ281834	3.9 × 55	€€	1000



Self Tapping Screws

BZP CR3 Countersunk Head Recessed AB DIN 7982-C-Z

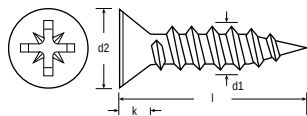

	(No. 4)	(No. 6)	(No. 8)	(No. 10)	(No. 12)	(No. 14)
d1	2.9mm	3.5mm	4.2mm	4.8mm	5.5mm	6.3mm
d2 max.	5.5	6.8	8.1	9.5	10.8	12.4
k max.	1.7	2.1	2.5	3	3.4	3.8
Recess no.	1	2	2	2	3	3

Box

Product Codes Begin **4200** Product Group 7

Article No.	Size	Box Qty.	Article No.	Size	Box Qty.	Article No.	Size	Box Qty.
OJ171999	4 × 1/4	1000	OJ172149	8 × 1/2	1000	OJ172293	10 × 2	500
OJ172002	4 × 5/16	1000	OJ172156	8 × 5/8	1000	OJ172309	12 × 5/8	500
OJ172019	4 × 3/8	1000	OJ172163	8 × 3/4	1000	OJ172316	12 × 3/4	500
OJ172026	4 × 1/2	1000	OJ172170	8 × 1	1000	OJ172323	12 × 1	500
OJ172033	4 × 5/8	1000	OJ172187	8 × 1.1/4	1000	OJ172330	12 × 1.1/4	500
OJ172040	4 × 3/4	1000	OJ172194	8 × 1.1/2	1000	OJ172347	12 × 1.1/2	500
OJ172057	4 × 1	1000	OJ172200	8 × 1.3/4	500	OJ172354	12 × 1.3/4	500
OJ172064	6 × 3/8	1000	OJ172217	8 × 2	500	OJ172361	12 × 2	250
OJ172071	6 × 1/2	1000	OJ172224	10 × 1/2	1000	OJ172378	14 × 3/4	500
OJ172088	6 × 5/8	1000	OJ172231	10 × 5/8	1000	OJ172385	14 × 1	250
OJ172095	6 × 3/4	1000	OJ172248	10 × 3/4	1000	OJ172392	14 × 1.1/4	250
OJ172101	6 × 1	1000	OJ172255	10 × 1	1000	OJ172408	14 × 1.1/2	250
OJ172118	6 × 1.1/4	1000	OJ172262	10 × 1.1/4	1000	OJ172415	14 × 1.3/4	250
OJ172125	6 × 1.1/2	1000	OJ172279	10 × 1.1/2	500	OJ172422	14 × 2	250
OJ172132	8 × 3/8	1000	OJ172286	10 × 1.3/4	500			

Small Box

Product Codes Begin **9TQSTCSKCR** Product Group 7

OJ084343	6 × 1/2	200	OJ084398	8 × 3/4	200	OJ445151	8 × 2	100
OJ084367	6 × 3/4	200	OJ084404	8 × 1	200	OJ084435	10 × 1	200
OJ084374	6 × 1	200	OJ445137	8 × 1.1/4	200	OJ445199	10 × 1.1/2	100
OJ084381	8 × 1/2	200	OJ084428	8 × 1.1/2	200	OJ445205	10 × 2	100

BZP CR3 Pan Head Recessed AB DIN 7981-C-Z

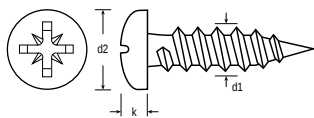

		(No. 4)	(No. 6)	(No. 8)	(No. 10)	(No. 12)	(No. 14)
d1		2.9mm	3.5mm	4.2mm	4.8mm	5.5mm	6.3mm
d2 max.		5.6	6.9	8.2	9.5	10.8	12.5
k max.		2.2	2.6	3.05	3.55	3.95	4.55
Recess no.		1	2	2	2	3	3

Box

Product Codes Begin **4203** Product Group **7**

Article No.	Size	Box Qty.
OJ172750	4 × 1/4	1000
OJ172767	4 × 5/16	1000
OJ172774	4 × 3/8	1000
OJ172781	4 × 1/2	1000
OJ172798	4 × 5/8	1000
OJ172804	4 × 3/4	1000
OJ172811	4 × 1	1000
OJ172828	6 × 1/4	1000
OJ172835	6 × 5/16	1000
OJ172842	6 × 3/8	1000
OJ172859	6 × 1/2	1000
OJ172866	6 × 5/8	1000
OJ172873	6 × 3/4	1000
OJ172880	6 × 1	1000
OJ172897	6 × 1.1/4	1000
OJ172903	6 × 1.1/2	1000
OJ172910	8 × 5/16	1000

OJ172927	8 × 3/8	1000
OJ172934	8 × 1/2	1000
OJ172941	8 × 5/8	1000
OJ172958	8 × 3/4	1000
OJ172965	8 × 1	1000
OJ172972	8 × 1.1/4	1000
OJ172989	8 × 1.1/2	1000
OJ172996	8 × 1.3/4	500
OJ173009	8 × 2	500
OJ173016	10 × 3/8	1000
OJ173023	10 × 1/2	1000
OJ173030	10 × 5/8	1000
OJ173047	10 × 3/4	1000
OJ173054	10 × 1	1000
OJ173061	10 × 1.1/4	1000
OJ173078	10 × 1.1/2	500
OJ173085	10 × 1.3/4	500

OJ173092	10 × 2	500
OJ173108	12 × 1/2	500
OJ173115	12 × 5/8	500
OJ173122	12 × 3/4	500
OJ173139	12 × 1	500
OJ173146	12 × 1.1/4	500
OJ173153	12 × 1.1/2	500
OJ173160	12 × 1.3/4	500
OJ173177	12 × 2	250
OJ173184	14 × 1/2	500
OJ173191	14 × 5/8	500
OJ173207	14 × 3/4	500
OJ173214	14 × 1	250
OJ173221	14 × 1.1/4	250
OJ173238	14 × 1.1/2	250
OJ173245	14 × 1.3/4	250
OJ173252	14 × 2	250

Small Box

Product Codes Begin **9TQSTSPANCR** Product Group **7**

OJ084169	6 × 1/2	200
OJ084176	6 × 5/8	200
OJ084183	6 × 3/4	200
OJ084190	6 × 1	200
OJ084220	8 × 1/2	200
OJ084237	8 × 5/8	200
OJ084244	8 × 3/4	200

OJ084251	8 × 1	200
OJ444895	8 × 1.1/4	200
OJ084275	8 × 1.1/2	200
OJ444918	8 × 2	100
OJ084282	10 × 1/2	200
OJ084299	10 × 3/4	200
OJ084305	10 × 1	200

OJ444956	10 × 1.1/4	200
OJ444963	10 × 1.1/2	100
OJ444970	10 × 2	100
OJ444987	12 × 3/4	100
OJ444994	12 × 1	100

BZP CR3 Pan Head Slotted AB DIN 7971-C

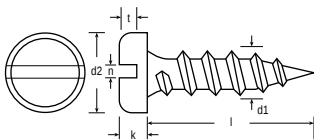

		(No. 4)	(No. 6)	(No. 8)	(No. 10)
d1		2.9mm	3.5mm	4.2mm	4.8mm
d2 max.		5.6	6.9	8.2	9.5
k max.		1.75	2.1	2.45	2.8
n		0.8	1	1.2	1.2
t min.		0.75	0.95	1.15	1.35

Product Codes Begin **4003** Product Group **7**

Article No.	Size	Box Qty.
OJ171616	4 × 3/8	1000
OJ171623	4 × 1/2	1000
OJ171678	6 × 3/8	1000
OJ171685	6 × 1/2	1000

OJ171739	8 × 3/8	1000
OJ171746	8 × 1/2	1000
OJ171760	8 × 3/4	1000
OJ171777	8 × 1	1000

OJ171814	10 × 1/2	1000
OJ171838	10 × 3/4	1000
OJ171845	10 × 1	1000



BZP CR3 Raised Head Recessed AB DIN 7983-C-Z

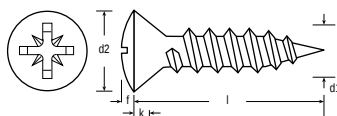

d1		(No. 6)	(No. 8)	(No. 10)
d2	max.	6.8	8.1	9.5
k	max.	2.1	2.5	3
n		1.2	1.4	1.5
Recess no.		2	2	2

Product Codes Begin 4202 Product Group 7

OJ172606	6 × 1/2	1000	OJ172637	6 × 1	1000	OJ172705	8 × 1.1/4	1000
OJ172613	6 × 5/8	1000	OJ172682	8 × 3/4	1000	OJ172712	8 × 1.1/2	1000
OJ172620	6 × 3/4	1000	OJ172699	8 × 1	1000	OJ172736	10 × 1	1000

BZP CR3 Flange Head Recessed AB BS4174

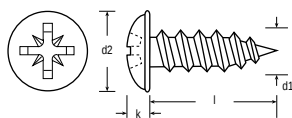

d1		(No. 4)	(No. 6)	(No. 8)	(No. 10)
d2	max.	6.53	8.15	9.75	11.38
k	max.	1.3	1.88	2.36	2.9
Recess no.		1	2	2	2

Product Codes Begin 4204 Product Group 7

Article No.	Size	Box Qty.						
OJ173443	4 × 3/8	1000	OJ173535	6 × 1.1/4	1000	OJ173627	8 × 1.1/2	1000
OJ173450	4 × 1/2	1000	OJ173542	6 × 1.1/2	1000	OJ173634	8 × 1.3/4	500
OJ173467	6 × 1/4	1000	OJ173559	8 × 5/16	1000	OJ173641	10 × 3/8	1000
OJ173474	6 × 5/16	1000	OJ173566	8 × 3/8	1000	OJ173658	10 × 1/2	1000
OJ173481	6 × 3/8	1000	OJ173573	8 × 1/2	1000	OJ173665	10 × 5/8	1000
OJ173498	6 × 1/2	1000	OJ173580	8 × 5/8	1000	OJ173672	10 × 3/4	1000
OJ173504	6 × 5/8	1000	OJ173597	8 × 3/4	1000	OJ173689	10 × 1	1000
OJ173511	6 × 3/4	1000	OJ173603	8 × 1	1000			
OJ173528	6 × 1	1000	OJ173610	8 × 1.1/4	1000			

Black Phosphate Flange Head Recessed AB BS4174

Product Codes Begin 4204 Product Group 7

OJ124902	6 × 1/4	1000	OJ313528	6 × 1.1/4	1000	OJ313658	8 × 1	1000
OJ313429	6 × 3/8	1000	OJ313542	6 × 1.1/2	1000	OJ313702	10 × 3/8	1000
OJ313443	6 × 1/2	1000	OJ313573	8 × 3/8	1000	OJ313726	10 × 1/2	1000
OJ313467	6 × 5/8	1000	OJ313597	8 × 1/2	1000	OJ313740	10 × 5/8	1000
OJ313481	6 × 3/4	1000	OJ313610	8 × 5/8	1000	OJ313764	10 × 3/4	1000
OJ313504	6 × 1	1000	OJ313634	8 × 3/4	1000	OJ236940	10 × 1	1000

> Self Tapping Screws

BZP Indented Hexagon Head AB BS4174

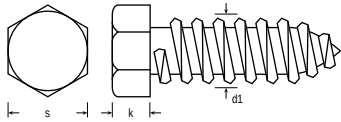

Gauge		14
d1	max.	6.25
d1	min.	6.10
s	max.	10.00
s	min.	9.78
k	max.	4.95
k	min.	4.65

Product Codes Begin [4005](#) Product Group [7](#)

OJ171975	14 × 3/4	500
OJ171982	14 × 1	250

BZP Hexagon Head SEMS AB

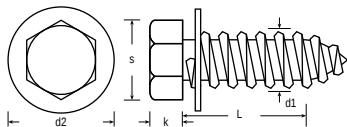

Gauge		14
d1	max.	6.25
d1	min.	6.10
s	max.	10.00
s	min.	9.78
k	max.	4.95
k	min.	4.65

Product Codes Begin [43 914](#) Product Group [7](#)

Article No.	Size	Box Qty.
OJ178325	14 × 3/4	500

BZP Countersunk Head Recessed B DIN 7982-F-Z

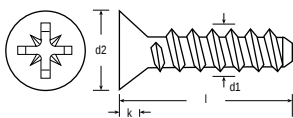

		(No. 6)	(No. 8)	(No. 10)	(No. 12)	(No. 14)
d1		3.5mm	4.2mm	4.8mm	5.5mm	6.3mm
d2	max.	6.8	8.1	9.5	10.8	12.4
k	min.	2.1	2.5	3	3.4	3.8
Recess no.		2	2	2	3	3

Product Codes Begin [4300](#) Product Group [7](#)

OJ173733	6 × 3/8	1000	OJ173788	14 × 1.1/4	250	OJ173801	14 × 1.3/4	250
OJ173757	8 × 3/8	1000	OJ173795	14 × 1.1/2	250	OJ173818	14 × 2	250



BZP Pan Head Recessed B DIN 7981-F-Z

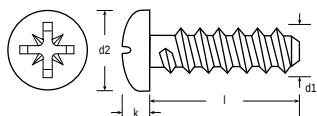

		(No. 2)	(No. 4)	(No. 6)	(No. 8)	(No. 10)	(No. 12)
d1		2.2mm	2.9mm	3.5mm	4.2mm	4.8mm	5.5mm
d2	max.	4.2	5.6	6.9	8.2	9.5	10.8
k	min.	1.8	2.2	2.6	3.05	3.55	3.95
Recess no.		1	1	2	2	2	3

Product Codes Begin **4303** Product Group **7**

OJ173825	2 × 3/16	1000	OJ173917	4 × 3/4	1000	OJ174006	8 × 3/8	1000
OJ173832	2 × 1/4	1000	OJ173924	6 × 1/4	1000	OJ174013	8 × 1/2	1000
OJ173849	2 × 5/16	1000	OJ173931	6 × 5/16	1000	OJ174037	8 × 3/4	1000
OJ173856	2 × 3/8	1000	OJ173948	6 × 3/8	1000	OJ174051	10 × 3/8	1000
OJ173863	4 × 3/16	1000	OJ173955	6 × 1/2	1000	OJ174068	10 × 1/2	1000
OJ173870	4 × 1/4	1000	OJ173962	6 × 5/8	1000	OJ174075	10 × 5/8	1000
OJ173887	4 × 3/8	1000	OJ173979	6 × 3/4	1000	OJ174082	10 × 3/4	1000
OJ173894	4 × 1/2	1000	OJ173986	8 × 1/4	1000	OJ174099	10 × 1	1000
OJ173900	4 × 5/8	1000	OJ173993	8 × 5/16	1000	OJ174105	12 × 1/2	500

BT Type 25 Thread Cutting Screws

BZP Pan Head Recessed

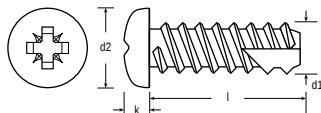

		Gauge	4	6	8
d1	max.		2.90	3.53	4.22
d1	min.		2.79	3.43	4.09
d2	max.		5.56	6.86	8.18
d2	min.		5.21	6.50	7.77
k	max.		2.03	2.46	2.92
k	min.		1.78	2.21	2.67
Recess No.			1	2	2

Product Codes Begin **4BTP** Product Group **7**

Article No.	Size	Box Qty.
OJ174136	4 × 1/4	1000
OJ174211	8 × 1/2	1000

Supertite Trilobular Threadforming Screws BZP, Clear Passivated & Lanolin Dipped

Countersunk Recessed Head DIN 7500-M-Z

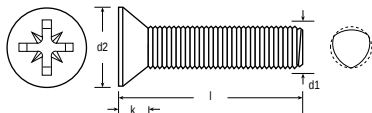

	d1	M3	M3.5	M4	M5	M6
d2	max.	5.60	6.50	7.50	9.20	11.00
k	max.	1.65	1.93	2.20	2.50	3.00
Recess	min.	1.48	1.34	1.60	2.06	2.46
Penetration	max.	1.73	1.80	2.06	2.51	2.92
Recess	No.	1	2	2	2	3

Product Codes Begin **4SMC** Product Group 7

OJ174471	M3 × 6	1000	OJ174549	M4 × 10	1000	OJ174594	M5 × 20	1000
OJ174488	M3 × 8	1000	OJ174556	M4 × 12	1000	OJ174600	M5 × 25	1000
OJ174495	M3 × 10	1000	OJ174563	M5 × 10	1000	OJ174624	M6 × 16	500
OJ174501	M3.5 × 8	1000	OJ174570	M5 × 12	1000	OJ174648	M6 × 25	500
OJ174532	M4 × 8	1000	OJ174587	M5 × 16	1000	OJ174655	M6 × 40	500

Supertite Trilobular Threadforming Screws BZP, Clear Passivated & Lanolin Dipped

Pan Head Recessed DIN 7500-C-Z

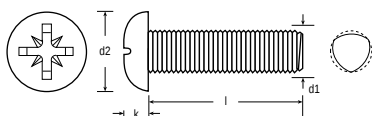

	d1	M2.5	M3	M3.5	M4	M5	M6
d2	max.	5	6	7	8	10	12
k	max.	2.12	2.52	2.82	3.25	3.95	4.75
Recess	min.	1.27	1.63	1.65	1.90	2.64	3.02
Penetration	max.	1.52	1.93	2.11	2.36	3.10	3.48
Recess	No.	1	1	2	2	2	3

Product Codes Begin **4SMP** Product Group 7

Article No.	Size	Box Qty.	Article No.	Size	Box Qty.	Article No.	Size	Box Qty.
OJ174761	M2.5 × 6	1000	OJ174877	M3.5 × 16	1000	OJ174976	M5 × 10	1000
OJ174778	M3 × 5	1000	OJ174884	M4 × 6	1000	OJ174983	M5 × 12	1000
OJ174785	M3 × 6	1000	OJ174891	M4 × 8	1000	OJ174990	M5 × 16	1000
OJ174792	M3 × 8	1000	OJ174907	M4 × 10	1000	OJ175010	M5 × 25	1000
OJ174808	M3 × 10	1000	OJ174914	M4 × 12	1000	OJ175027	M6 × 12	500
OJ174815	M3 × 12	1000	OJ174921	M4 × 16	1000	OJ175034	M6 × 16	500
OJ174822	M3 × 16	1000	OJ174938	M4 × 20	1000	OJ175041	M6 × 20	500
OJ174839	M3.5 × 6	1000	OJ174945	M4 × 25	1000	OJ175058	M6 × 25	500
OJ174846	M3.5 × 8	1000	OJ174952	M4 × 30	1000	OJ175065	M6 × 30	500
OJ174853	M3.5 × 10	1000	OJ174969	M5 × 8	1000	OJ175072	M6 × 40	500



Hexagon Washer Head DIN 7500-D-E

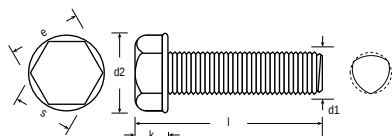

	d1	M5	M6
d2 max.		10.40	13.00
k min.		4.48	5.19
s max.		8.00	10.00
e max.		8.71	10.95

Product Codes Begin **4SMH** Product Group 7

OJ174679	M5 × 10	1000	OJ174716	M6 × 10	500	OJ174747	M6 × 20	500
OJ174686	M5 × 12	1000	OJ174723	M6 × 12	500	OJ174754	M6 × 25	500
OJ174693	M5 × 16	1000	OJ174730	M6 × 16	500			

Hammer Drive Screws

Brassed Type U Round Head BS4174

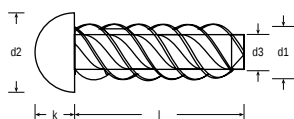

	d1	2	4	6
d2 max.		4.11	5.36	6.60
k max.		1.75	2.18	2.62
d3 max.		2.54	2.95	3.56
d1 max.		2.11	2.44	2.95

Product Codes Begin **4530** Product Group 7

Article No.	Size	Box Qty.	Article No.	Size	Box Qty.	Article No.	Size	Box Qty.
OJ314464	2 × 1/8	1000	OJ314518	4 × 3/16	1000	OJ314556	6 × 1/4	1000
OJ314471	2 × 3/16	1000	OJ314525	4 × 1/4	1000	OJ314570	6 × 3/8	1000
OJ314488	2 × 1/4	1000	OJ314532	4 × 5/16	1000	OJ314587	6 × 1/2	1000
OJ314495	2 × 5/16	1000	OJ314549	4 × 3/8	1000			

BZP Self Drilling Screws

Cross Recessed Pan Head DIN 7504-N-Z

Product Codes Begin **4SDPH** Product Group 60

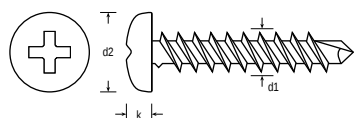

Article No.	Size	Box Qty.
OJ174372	3.5 × 9.5	1000



THUNDERBOLT™

The one and only Thunderbolt™ is the original self-tapping anchor with the power to be used on a whole range of construction materials, including concrete, stone, brick and block. The threaded anchor and self-tapping action allows for safe anchorage, with the substrate becoming the nut to the bolt-applying a tried and tested method for metals and wood to a broader selection of materials.

A truly versatile anchor, the Thunderbolt™ can be installed nearer to edges and closer together at varying embedment depths, providing a stress-free fixing. Installation is quick and easy, making it the ideal general purpose anchor, even on temporary jobs as it's completely removable. Using standard sized drill bits, the Thunderbolt™ is the cost effective fix for any job.

**THE ORIGINAL
AND BEST SELLING
ALL-PURPOSE ANCHOR**

NOTHING CAN STOP THE MIGHTY THUNDERBOLT™

- Fixes over full embedment giving secure fix through voids.
- Balancing thread ensures correct alignment of anchor.
- One-piece non-expansion fixing anchor for close-to-edge fixing.
- Self-tapping thread allows for total removal of anchor.
- 25° helix angle of thread for reduced setting torque.
- Core diameter designed to avoid trapping dust whilst maintaining optimum performance loads.
- Manufactured in accordance with ISO 9000 from high grade steel.
- Achieves a tensile strength of 800N/mm² (after heat treatment).

SUBSTRATE SUITABILITY



HOW IT WORKS

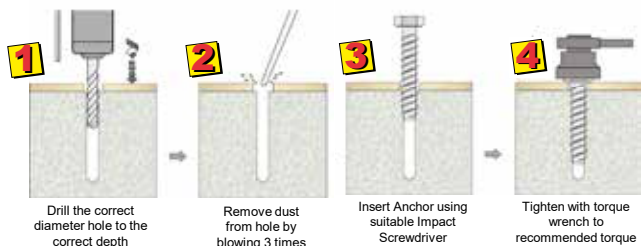

1 WHY IT'S BETTER

- Gives a mechanical interlock between construction material and the fixing, with no expansion stress.
- Fixes close to the edge and is totally removable.
- Fixes along the entire thread length to enable fixing through hollow sections.
- No marking out required, fix straight through your fixture.
- Works in concrete, brick, wood, marble, block, stone and more.
- Uses smaller drill bits than traditional bolts and sleeve anchors.
- Independently tested to European standards.

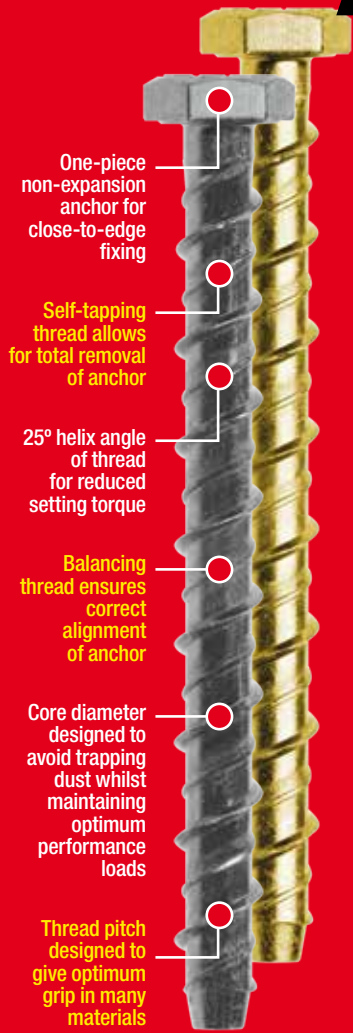

2 WHO USES IT

- General builders.
- Property developers.
- Property maintenance.
- Shop fitters.
- Plumbers.
- Restoration contractors.

A FORCE TO BE RECKONED WITH



Thunderbolt™ Zinc and Yellow Hex Head Masonry Anchor

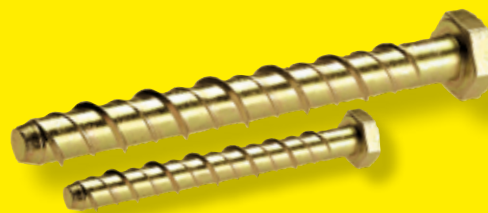

Code	Description	Clearance Hole (fixture)	Drill Bit Diameter	Max Fixture Thickness	Box Qty
ZZV35155	8 x 60mm	12mm	8mm	20mm	100
ZZV35156	8 x 75mm	12mm	8mm	35mm	100
ZZV35157	8 x 100mm	12mm	8mm	60mm	100
ZZV35158	8 x 130mm	12mm	8mm	90mm	50
ZZV35159	8 x 150mm	12mm	8mm	110mm	50
ZZV35160	10 x 60mm	14mm	10mm	10mm	50
ZZV35161	10 x 75mm	14mm	10mm	25mm	50
ZZV35162	10 x 100mm	14mm	10mm	50mm	50
ZZV35163	10 x 130mm	14mm	10mm	80mm	25
ZZV35164	10 x 150mm	14mm	10mm	100mm	25
ZZV35165	12 x 75mm	16mm	12mm	15mm	50
ZZV35166	12 x 100mm	16mm	12mm	40mm	50
ZZV35167	12 x 130mm	16mm	12mm	70mm	25
ZZV35168	12 x 150mm	16mm	12mm	90mm	20
ZZV35169	12 x 200mm	16mm	12mm	140mm	20
ZZV35174	14 x 75mm	18mm	14mm	5mm	25
ZZV35175	14 x 100mm	18mm	14mm	30mm	25
ZZV35176	14 x 130mm	18mm	14mm	60mm	20
ZZV35177	14 x 150mm	18mm	14mm	80mm	10
ZZV35178	14 x 200mm	18mm	14mm	130mm	10

Thunderbolt™ Zinc and Yellow Hex Head Masonry Anchor



Code	Description	Clearance Hole (fixture)	Drill Bit Diameter	Max Fixture Thickness	Box Qty
ZZV35156CE	8 x 80mm	12mm	8mm	5mm	100
ZZV35157CE	8 x 100mm	12mm	8mm	25mm	100
ZZV35158CE	8 x 130mm	12mm	8mm	55mm	50
ZZV35159CE	8 x 150mm	12mm	8mm	75mm	50
ZZV35162CE	10 x 100mm	14mm	10mm	15mm	50
ZZV35163CE	10 x 130mm	14mm	10mm	45mm	25
ZZV35164CE	10 x 150mm	14mm	10mm	65mm	25
ZZV35166CE	12 x 100mm	16mm	12mm	5mm	50
ZZV35167CE	12 x 130mm	16mm	12mm	35mm	25
ZZV35168CE	12 x 150mm	16mm	12mm	55mm	20
ZZV35169CE	12 x 200mm	16mm	12mm	105mm	20

Thunderbolt™ Zinc and Yellow Hex Flange Head Masonry Anchor



Code	Description	Clearance Hole (fixture)	Drill Bit Diameter	Max Fixture Thickness	Box Qty
ZZV35146	5 x 30mm	7mm	5mm	5mm	200
ZZV35147	5 x 50mm	7mm	5mm	25mm	100
ZZV35148	5 x 75mm	7mm	5mm	50mm	100
ZZV35149	5 x 100mm	7mm	5mm	75mm	100
ZZV35173	6 x 30mm	10mm	6mm	5mm	100
ZZV35150	6 x 50mm	10mm	6mm	20mm	100
ZZV35151	6 x 75mm	10mm	6mm	45mm	100
ZZV35152	6 x 100mm	10mm	6mm	70mm	100
ZZV35153	6 x 130mm	10mm	6mm	100mm	100
ZZV35154	6 x 150mm	10mm	6mm	120mm	100

Thunderbolt™ Zinc and Yellow Countersunk 6 Lobe Masonry Anchor

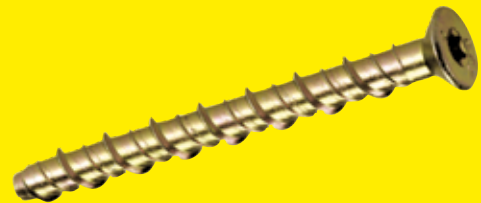

- Complete with drive bit.

Code	Description	Clearance Hole (fixture)	Drill Bit Diameter	Max Fixture Thickness	Box Qty
ZZV35137	5 x 30mm - T25	7mm	5mm	5mm	200
ZZV35138	5 x 50mm - T25	7mm	5mm	25mm	100
ZZV35139	5 x 75mm - T25	7mm	5mm	50mm	100
ZZV35140	5 x 100mm - T25	7mm	5mm	75mm	100
ZZV35141	6 x 50mm - T30	10mm	6mm	20mm	100
ZZV35142	6 x 75mm - T30	10mm	6mm	45mm	100
ZZV35143	6 x 100mm - T30	10mm	6mm	70mm	100
ZZV35144	6 x 130mm - T30	10mm	6mm	100mm	100
ZZV35145	6 x 150mm - T30	10mm	6mm	120mm	100

Thunderbolt™ Zinc and Yellow Hook and Eye Masonry Anchor



Code	Description	Clearance Hole (fixture)	Drill Bit Diameter	Box Qty
ZZV70872	6 x 50mm - Hook	10mm	6mm	50
ZZV70874	8 x 55mm - Hook	12mm	8mm	50
ZZV70873	6 x 50mm - Eye	10mm	6mm	50
ZZV70875	8 x 55mm - Eye	12mm	8mm	50



Thunderbolt™ Mechanical Galvanised Hex Head Masonry Anchor

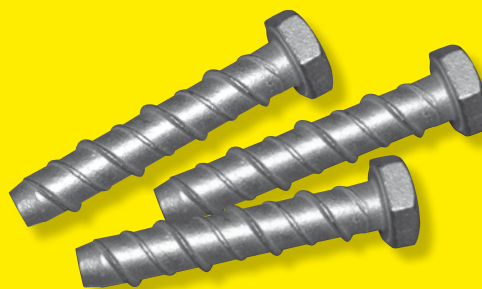

Code	Description	Clearance Hole (fixture)	Drill Bit Diameter	Max Fixture Thickness	Box Qty
ZZV71786	8 x 60mm	12mm	8mm	20mm	100
ZZV71787	8 x 100mm	12mm	8mm	60mm	100
ZZV71788	8 x 150mm	12mm	8mm	110mm	50
ZZV71789	10 x 60mm	14mm	10mm	10mm	50
ZZV71790	10 x 100mm	14mm	10mm	50mm	50
ZZV71791	10 x 150mm	14mm	10mm	100mm	25
ZZV71792	12 x 100mm	16mm	12mm	40mm	50
ZZV71793	12 x 150mm	16mm	12mm	90mm	20
ZZV71794	12 x 200mm	16mm	12mm	140mm	20
ZZV35170	16 x 100mm	20mm	16mm	20mm	10
ZZV35171	16 x 150mm	20mm	16mm	70mm	10
ZZV35172	16 x 200mm	20mm	16mm	120mm	10
ZZV35171CE	16 x 150mm	20mm	16mm	70mm	10
ZZV35172CE	16 x 200mm	20mm	16mm	120mm	10

Thunderbolt™ Mechanical Galvanised Hex Flange Head Masonry Anchor

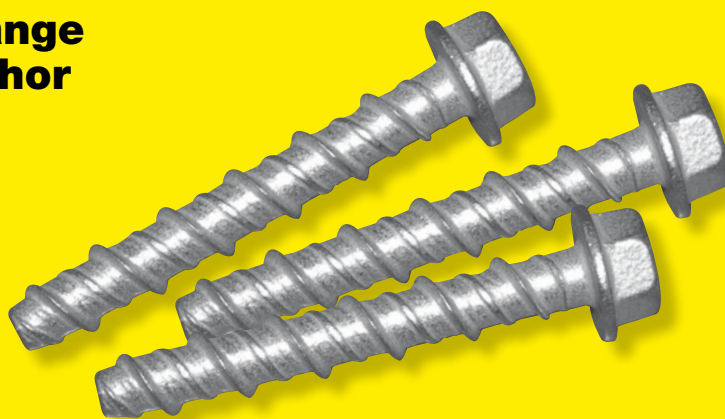

Code	Description	Clearance Hole (fixture)	Drill Bit Diameter	Max Fixture Thickness	Box Qty
ZZV71783	6 x 50mm	10mm	6mm	20mm	100
ZZV71784	6 x 75mm	10mm	6mm	45mm	100
ZZV71785	6 x 100mm	10mm	6mm	70mm	100

High Tensile Hexagon Bolts & Sets Metric Thread

Hexagon Bolts DIN 931 ISO 898-1 Grade 8.8

Thread Lengths – Metric Hexagon Bolts Only

Up to 125mm = 2× diameter plus 6mm.

125mm-200mm = 2× diameter plus 12mm. Over 200mm = 2× diameter plus 25mm.

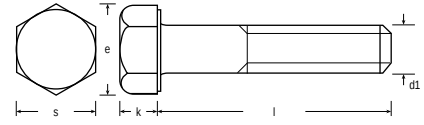

d1	M5	M6	M8	M10	M12	M14	M16	M20	M24	M27	M30	M33	M36	M42	M45
e	8.79	11.05	14.38	18.9	21.1	24.49	26.75	35.72	39.98	45.20	50.85	55.37	60.79	71.3	76.95
k	3.8	4	5.3	6.4	7.5	8.8	10	13	15	17	18.70	21	22.50	26	28
s	8	10	13	17	19	22	24	30	36	41	46	50	55	65	70

Product Codes Begin **&MHB** Product Group 3

Article No.	Size	Finish	Box Qty.												
OJ301273	M5 × 25	BZP	500	OJ136066	M10 × 200	BZP	50	OJ302935	M16 × 200	BZP	25				
OJ301280	M5 × 30	BZP	500	OJ242552	M12 × 40	BZP	100	OJ421896	M16 × 220	BZP	10				
OJ301297	M5 × 35	BZP	200	OJ242569	M12 × 45	BZP	100	OJ676548	M16 × 240	BZP	25				
OJ301303	M5 × 40	BZP	200	OJ242576	M12 × 50	BZP	100	OJ421902	M16 × 260	BZP	10				
OJ301310	M5 × 45	BZP	200	OJ302218	M12 × 55	BZP	100	OJ421919	M16 × 280	BZP	10				
OJ301327	M5 × 50	BZP	200	OJ024745	M12 × 60	BZP	100	OJ421926	M16 × 300	BZP	5				
OJ301358	M5 × 70	BZP	200	OJ302249	M12 × 65	BZP	50	OJ421933	M18 × 60	BZP	25				
OJ301365	M6 × 25	BZP	500	OJ242583	M12 × 70	BZP	50	OJ421940	M18 × 70	BZP	25				
OJ301389	M6 × 30	BZP	500	OJ302270	M12 × 75	BZP	50	OJ421957	M18 × 80	BZP	20				
OJ301402	M6 × 35	BZP	200	OJ242590	M12 × 80	BZP	50	OJ421964	M18 × 100	BZP	20				
OJ301426	M6 × 40	BZP	200	OJ024776	M12 × 90	BZP	50	OJ303000	M20 × 55	BZP	25				
OJ301440	M6 × 45	BZP	200	OJ242606	M12 × 100	BZP	50	OJ024578	M20 × 60	BZP	25				
OJ301464	M6 × 50	BZP	200	OJ302324	M12 × 110	BZP	50	OJ024585	M20 × 65	BZP	25				
OJ301488	M6 × 55	BZP	200	OJ242484	M12 × 120	BZP	50	OJ024592	M20 × 70	BZP	25				
OJ301501	M6 × 60	BZP	200	OJ302355	M12 × 130	BZP	50	OJ144443	M20 × 75	BZP	25				
OJ301518	M6 × 65	BZP	200	OJ302379	M12 × 140	BZP	50	OJ024608	M20 × 80	BZP	25				
OJ301532	M6 × 70	BZP	200	OJ302393	M12 × 150	BZP	50	OJ024615	M20 × 90	BZP	25				
OJ301556	M6 × 75	BZP	200	OJ136073	M12 × 160	BZP	25	OJ144467	M20 × 100	BZP	25				
OJ301570	M6 × 80	BZP	200	OJ213392	M12 × 170	BZP	25	OJ303093	M20 × 110	BZP	25				
OJ301594	M6 × 90	BZP	100	OJ302430	M12 × 180	BZP	25	OJ303116	M20 × 120	BZP	25				
OJ301617	M6 × 100	BZP	100	OJ136080	M12 × 200	BZP	25	OJ144474	M20 × 130	BZP	25				
OJ135984	M6 × 110	BZP	100	OJ421827	M12 × 220	BZP	20	OJ303147	M20 × 140	BZP	25				
OJ301624	M8 × 30	BZP	200	OJ421834	M12 × 230	BZP	20	OJ144481	M20 × 150	BZP	25				
OJ301631	M8 × 35	BZP	200	OJ421841	M12 × 240	BZP	20	OJ303178	M20 × 160	BZP	10				
OJ301655	M8 × 40	BZP	200	OJ421858	M12 × 250	BZP	20	OJ303192	M20 × 170	BZP	10				
OJ301679	M8 × 45	BZP	200	OJ302461	M14 × 50	BZP	50	OJ303215	M20 × 180	BZP	10				
OJ024684	M8 × 50	BZP	200	OJ302485	M14 × 55	BZP	50	OJ421971	M20 × 190	BZP	5				
OJ024431	M8 × 55	BZP	200	OJ302508	M14 × 60	BZP	50	OJ303239	M20 × 200	BZP	10				
OJ024448	M8 × 60	BZP	200	OJ302522	M14 × 65	BZP	50	OJ283616	M20 × 220	BZP	25				
OJ301716	M8 × 65	BZP	200	OJ302546	M14 × 70	BZP	50	OJ421988	M20 × 240	BZP	5				
OJ024455	M8 × 70	BZP	200	OJ302560	M14 × 75	BZP	50	OJ421995	M20 × 250	BZP	5				
OJ301747	M8 × 75	BZP	200	OJ302584	M14 × 80	BZP	50	OJ422008	M20 × 260	BZP	5				
OJ301761	M8 × 80	BZP	200	OJ136097	M14 × 90	BZP	50	OJ422015	M20 × 280	BZP	5				
OJ301785	M8 × 90	BZP	100	OJ302614	M14 × 100	BZP	50	OJ422022	M20 × 300	BZP	5				
OJ301808	M8 × 100	BZP	100	OJ136103	M14 × 110	BZP	50	OJ422039	M22 × 70	BZP	10				
OJ135991	M8 × 110	BZP	100	OJ136110	M14 × 120	BZP	50	OJ422046	M22 × 80	BZP	10				
OJ136004	M8 × 120	BZP	100	OJ136127	M14 × 130	BZP	50	OJ213408	M22 × 90	BZP	10				
OJ136011	M8 × 130	BZP	100	OJ136134	M14 × 140	BZP	25	OJ213415	M22 × 100	BZP	10				
OJ136028	M8 × 140	BZP	100	OJ136141	M14 × 150	BZP	25	OJ422053	M22 × 120	BZP	10				
OJ136035	M8 × 150	BZP	100	OJ421865	M14 × 160	BZP	10	OJ422060	M22 × 130	BZP	10				
OJ301884	M10 × 35	BZP	100	OJ302690	M16 × 45	BZP	50	OJ422077	M22 × 140	BZP	10				
OJ024462	M10 × 40	BZP	100	OJ242491	M16 × 50	BZP	50	OJ422084	M22 × 150	BZP	5				
OJ301914	M10 × 45	BZP	100	OJ302720	M16 × 55	BZP	50	OJ303352	M24 × 65	BZP	25				
OJ024479	M10 × 50	BZP	100	OJ242507	M16 × 60	BZP	50	OJ024622	M24 × 70	BZP	25				
OJ301938	M10 × 55	BZP	100	OJ242514	M16 × 65	BZP	50	OJ024639	M24 × 75	BZP	25				
OJ024486	M10 × 60	BZP	100	OJ242521	M16 × 70	BZP	50	OJ024646	M24 × 80	BZP	25				
OJ024493	M10 × 65	BZP	100	OJ024554	M16 × 75	BZP	50	OJ024653	M24 × 90	BZP	10				
OJ242538	M10 × 70	BZP	100	OJ024561	M16 × 80	BZP	25	OJ024660	M24 × 100	BZP	10				
OJ301983	M10 × 75	BZP	100	OJ144399	M16 × 90	BZP	25	OJ024677	M24 × 110	BZP	10				
OJ242545	M10 × 80	BZP	100	OJ144405	M16 × 100	BZP	25	OJ303437	M24 × 120	BZP	10				
OJ302010	M10 × 90	BZP	100	OJ302812	M16 × 110	BZP	25	OJ303451	M24 × 130	BZP	10				
OJ302034	M10 × 100	BZP	100	OJ302836	M16 × 120	BZP	25	OJ303475	M24 × 140	BZP	10				
OJ302058	M10 × 110	BZP	50	OJ144412	M16 × 130	BZP	25	OJ303499	M24 × 150	BZP	10				
OJ302072	M10 × 120	BZP	50	OJ302867	M16 × 140	BZP	25	OJ136165	M24 × 160	BZP	10				
OJ302096	M10 × 130	BZP	50	OJ144429	M16 × 150	BZP	25	OJ213422	M24 × 170	BZP	10				
OJ302119	M10 × 140	BZP	50	OJ136158	M16 × 160	BZP	25	OJ136172	M24 × 180	BZP	10				
OJ302133	M10 × 150	BZP	50	OJ421872	M16 × 170	BZP	10	OJ136189	M24 × 200	BZP	10				
OJ136042	M10 × 160	BZP	50	OJ302911	M16 × 180	BZP	25	OJ213439	M24 × 220	BZP	10				
OJ136059	M10 × 180	BZP	50	OJ421889	M16 × 190	BZP	10	OJ213446	M24 × 240	BZP	10				



Article No.	Size	Finish	Box Qty.										
OJ422091	M24 x 250	BZP	5	OJ301686	M8 x 50	SC	200	OJ302928	M16 x 200	SC	25		
OJ422107	M24 x 260	BZP	25	OJ301693	M8 x 60	SC	200	OJ302942	M16 x 220	SC	25		
OJ422121	M24 x 280	BZP	10	OJ301709	M8 x 65	SC	200	OJ302959	M16 x 240	SC	25		
OJ422107	M24 x 300	BZP	5	OJ301723	M8 x 70	SC	200	OJ302966	M16 x 260	SC	25		
OJ213453	M27 x 100	BZP	10	OJ301730	M8 x 75	SC	200	OJ302973	M16 x 280	SC	25		
OJ526249	M27 x 110	BZP	5	OJ301754	M8 x 80	SC	200	OJ302980	M16 x 300	SC	25		
OJ213460	M27 x 120	BZP	10	OJ301778	M8 x 90	SC	100	OJ213224	M18 x 100	SC	25		
OJ280691	M12 x 45	HDG	100	OJ301792	M8 x 100	SC	100	OJ302997	M20 x 55	SC	25		
OJ676357	M12 x 50	HDG	100	OJ301815	M8 x 110	SC	100	OJ303017	M20 x 60	SC	25		
OJ280707	M12 x 55	HDG	100	OJ301853	M8 x 150	SC	100	OJ303024	M20 x 65	SC	25		
OJ676364	M12 x 60	HDG	100	OJ301877	M10 x 35	SC	100	OJ303031	M20 x 70	SC	25		
OJ676371	M12 x 65	HDG	50	OJ301891	M10 x 40	SC	100	OJ303048	M20 x 75	SC	25		
OJ676388	M12 x 70	HDG	50	OJ301907	M10 x 45	SC	100	OJ303055	M20 x 80	SC	25		
OJ280714	M12 x 75	HDG	50	OJ301921	M10 x 50	SC	100	OJ303062	M20 x 90	SC	25		
OJ676395	M12 x 80	HDG	50	OJ213118	M10 x 55	SC	100	OJ303079	M20 x 100	SC	25		
OJ676401	M12 x 90	HDG	50	OJ301945	M10 x 60	SC	100	OJ303086	M20 x 110	SC	25		
OJ676418	M12 x 100	HDG	50	OJ301952	M10 x 65	SC	100	OJ303109	M20 x 120	SC	25		
OJ246628	M12 x 110	HDG	50	OJ301969	M10 x 70	SC	100	OJ303123	M20 x 130	SC	25		
OJ246635	M12 x 130	HDG	50	OJ301976	M10 x 75	SC	100	OJ303130	M20 x 140	SC	25		
OJ280721	M12 x 150	HDG	50	OJ301990	M10 x 80	SC	100	OJ303154	M20 x 150	SC	25		
OJ280738	M16 x 50	HDG	50	OJ302003	M10 x 90	SC	100	OJ303161	M20 x 160	SC	10		
OJ280745	M16 x 55	HDG	50	OJ302027	M10 x 100	SC	100	OJ303185	M20 x 170	SC	10		
OJ676425	M16 x 60	HDG	50	OJ302041	M10 x 110	SC	50	OJ303208	M20 x 180	SC	10		
OJ676432	M16 x 65	HDG	50	OJ302065	M10 x 120	SC	50	OJ213231	M20 x 190	SC	10		
OJ676449	M16 x 70	HDG	50	OJ302089	M10 x 130	SC	50	OJ303222	M20 x 200	SC	10		
OJ676456	M16 x 75	HDG	50	OJ302126	M10 x 150	SC	50	OJ303246	M20 x 220	SC	10		
OJ676463	M16 x 80	HDG	25	OJ302157	M10 x 180	SC	50	OJ303253	M20 x 240	SC	10		
OJ676470	M16 x 90	HDG	25	OJ302171	M12 x 40	SC	100	OJ213248	M20 x 250	SC	5		
OJ676487	M16 x 100	HDG	25	OJ302188	M12 x 45	SC	100	OJ303260	M20 x 260	SC	5		
OJ676494	M16 x 110	HDG	25	OJ302195	M12 x 50	SC	100	OJ135953	M20 x 280	SC	5		
OJ676500	M16 x 120	HDG	25	OJ302201	M12 x 55	SC	100	OJ303277	M20 x 300	SC	5		
OJ676517	M16 x 130	HDG	25	OJ302225	M12 x 60	SC	100	OJ303307	M22 x 90	SC	25		
OJ676524	M16 x 140	HDG	25	OJ302232	M12 x 65	SC	50	OJ135960	M22 x 130	SC	10		
OJ676531	M16 x 150	HDG	25	OJ302256	M12 x 70	SC	50	OJ303345	M24 x 65	SC	25		
OJ280752	M16 x 160	HDG	25	OJ302263	M12 x 75	SC	50	OJ303369	M24 x 70	SC	25		
OJ265636	M16 x 200	HDG	25	OJ302287	M12 x 80	SC	50	OJ303376	M24 x 75	SC	25		
OJ526232	M20 x 60	HDG	20	OJ302294	M12 x 90	SC	50	OJ303383	M24 x 80	SC	25		
OJ280769	M20 x 65	HDG	25	OJ302300	M12 x 100	SC	50	OJ303390	M24 x 90	SC	10		
OJ676555	M20 x 70	HDG	25	OJ302317	M12 x 110	SC	50	OJ303406	M24 x 100	SC	10		
OJ676562	M20 x 75	HDG	25	OJ302331	M12 x 120	SC	50	OJ303413	M24 x 110	SC	10		
OJ676579	M20 x 80	HDG	25	OJ302348	M12 x 130	SC	50	OJ303420	M24 x 120	SC	10		
OJ676586	M20 x 90	HDG	25	OJ302362	M12 x 140	SC	50	OJ303444	M24 x 130	SC	10		
OJ676593	M20 x 100	HDG	25	OJ302386	M12 x 150	SC	50	OJ303468	M24 x 140	SC	10		
OJ676609	M20 x 110	HDG	25	OJ302409	M12 x 160	SC	25	OJ303482	M24 x 150	SC	10		
OJ676616	M20 x 120	HDG	25	OJ302423	M12 x 180	SC	25	OJ303505	M24 x 160	SC	10		
OJ676623	M20 x 130	HDG	25	OJ302447	M12 x 200	SC	25	OJ303529	M24 x 180	SC	10		
OJ676630	M20 x 140	HDG	25	OJ213125	M12 x 210	SC	25	OJ303536	M24 x 200	SC	10		
OJ676647	M20 x 150	HDG	25	OJ213149	M12 x 230	SC	25	OJ303543	M24 x 220	SC	10		
OJ246642	M20 x 160	HDG	10	OJ213156	M12 x 240	SC	25	OJ303550	M24 x 240	SC	10		
OJ246659	M20 x 180	HDG	10	OJ213163	M12 x 250	SC	25	OJ303567	M24 x 260	SC	10		
OJ246666	M20 x 200	HDG	10	OJ213170	M14 x 45	SC	50	OJ303581	M24 x 300	SC	10		
OJ676654	M24 x 75	HDG	25	OJ302454	M14 x 50	SC	50	OJ213279	M27 x 100	SC	10		
OJ676661	M24 x 80	HDG	25	OJ302492	M14 x 60	SC	50	OJ213309	M30 x 80	SC	10		
OJ676678	M24 x 90	HDG	10	OJ302553	M14 x 75	SC	50	OJ213316	M30 x 90	SC	10		
OJ676685	M24 x 100	HDG	10	OJ302591	M14 x 90	SC	50	OJ303598	M30 x 100	SC	10		
OJ676692	M24 x 110	HDG	10	OJ302607	M14 x 100	SC	50	OJ303604	M30 x 110	SC	10		
OJ676708	M24 x 120	HDG	10	OJ302676	M14 x 160	SC	25	OJ303611	M30 x 120	SC	10		
OJ676715	M24 x 130	HDG	10	OJ302683	M16 x 45	SC	50	OJ303628	M30 x 130	SC	5		
OJ676722	M24 x 140	HDG	10	OJ302706	M16 x 50	SC	50	OJ303635	M30 x 140	SC	10		
OJ676739	M24 x 150	HDG	10	OJ302713	M16 x 55	SC	50	OJ303642	M30 x 150	SC	10		
OJ280776	M24 x 160	HDG	10	OJ302737	M16 x 60	SC	50	OJ303659	M30 x 160	SC	10		
OJ280783	M24 x 180	HDG	10	OJ302744	M16 x 65	SC	50	OJ213323	M30 x 170	SC	10		
OJ280790	M24 x 200	HDG	10	OJ302751	M16 x 70	SC	50	OJ303666	M30 x 180	SC	10		
OJ676746	M30 x 110	HDG	10	OJ302768	M16 x 75	SC	50	OJ303673	M30 x 200	SC	10		
OJ676753	M30 x 120	HDG	10	OJ302775	M16 x 80	SC	25	OJ283647	M30 x 220	SC	10		
OJ676760	M30 x 130	HDG	10	OJ302782	M16 x 90	SC	50	OJ283654	M30 x 300	SC	10		
OJ676777	M30 x 140	HDG	10	OJ302799	M16 x 100	SC	25	OJ213330	M36 x 110	SC	10		
OJ676784	M30 x 160	HDG	5	OJ302805	M16 x 110	SC	25	OJ213347	M36 x 120	SC	10		
OJ676791	M30 x 180	HDG	10	OJ302829	M16 x 120	SC	25	OJ213354	M36 x 140	SC	5		
OJ676807	M30 x 200	HDG	10	OJ302843	M16 x 130	SC	25	OJ213361	M36 x 150	SC	5		
OJ301419	M6 x 40	SC	200	OJ302850	M16 x 140	SC	25	OJ213378	M36 x 180	SC	5		
OJ301563	M6 x 80	SC	200	OJ302874	M16 x 150	SC	25						
OJ301600	M6 x 100	SC	100	OJ302881	M16 x 160	SC	25						
OJ213095	M8 x 30	SC	200	OJ302898	M16 x 170	SC	25						
OJ135946	M8 x 35	SC	200	OJ302904	M16 x 180	SC	25						
OJ301648	M8 x 40	SC	200	OJ213187	M16 x 190	SC	25						

> High Tensile Hexagon Bolts & Sets Metric Thread

Hexagon Bolts DIN 931 ISO 898-1 Grade 10.9

A higher tensile strength than grade 8.8

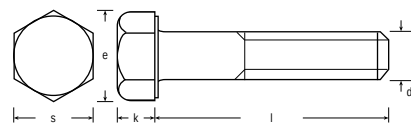

d1	M8	M10	M12	M14	M16	M18	M20	M22	M24	M27	M30	M36
e	14.38	18.9	21.1	24.49	26.75	30.14	33.35	35.72	39.98	45.20	50.85	60.79
k	5.3	6.4	7.5	8.8	10	11.5	12.5	14	15	17	18.7	22.5
s	13	17	19	22	24	27	30	32	36	41	46	55

Product Codes Begin **Q10931** Product Group **10**

Article No.	Size	Finish	Box Qty.	Article No.	Size	Finish	Box Qty.	Article No.	Size	Finish	Box Qty.
HX372952	M8×50	BZP/C	200	HX374185	M24×70	BZP/C	25	HX373232	M10×200	SC	25
HX373102	M10×50	BZP/C	100	HX374215	M24×80	BZP/C	25	HX189710	M12×40	SC	100
HX373119	M10×60	BZP/C	100	HX374222	M24×90	BZP/C	25	HX189727	M12×45	SC	100
HX373126	M10×70	BZP/C	100	HX374239	M24×100	BZP/C	25	HX189734	M12×50	SC	100
HX373140	M10×75	BZP/C	100	IC352510	M27×120	BZP/C	25	HX189741	M12×55	SC	100
HX373171	M10×90	BZP/C	50	HX372815	M6×35	SC	200	HX189758	M12×60	SC	100
HX373249	M12×40	BZP/C	100	HX372839	M6×40	SC	200	HX189765	M12×65	SC	50
HX373256	M12×45	BZP/C	100	HX372846	M6×45	SC	200	HX189772	M12×70	SC	50
HX373263	M12×50	BZP/C	100	HX372853	M6×50	SC	200	HX189789	M12×75	SC	50
HX373287	M12×60	BZP/C	100	HX372921	M8×30	SC	200	HX189796	M12×80	SC	50
HX373294	M12×70	BZP/C	50	HX189437	M8×35	SC	200	HX189802	M12×90	SC	50
HX373300	M12×80	BZP/C	50	HX372938	M8×40	SC	200	HX189819	M12×100	SC	50
HX373317	M12×90	BZP/C	50	HX372945	M8×45	SC	200	HX189826	M12×110	SC	50
HX373324	M12×100	BZP/C	50	HX189468	M8×50	SC	200	HX189833	M12×120	SC	50
IC346243	M12×110	BZP/C	100	HX189475	M8×55	SC	200	HX189840	M12×130	SC	50
HX373393	M14×45	BZP/C	100	HX189482	M8×60	SC	200	HX189857	M12×140	SC	50
HX373409	M14×50	BZP/C	100	HX372976	M8×65	SC	200	HX189864	M12×150	SC	50
IC339603	M14×60	BZP/C	50	HX189499	M8×70	SC	200	HX373331	M12×160	SC	50
HX373416	M14×70	BZP/C	50	HX189505	M8×80	SC	200	HX373355	M12×180	SC	50
HX373430	M14×80	BZP/C	50	HX189512	M8×90	SC	100	HX189871	M14×45	SC	100
HX373447	M14×90	BZP/C	50	HX373010	M8×100	SC	100	HX189888	M14×50	SC	100
HX373454	M14×100	BZP/C	25	HX373027	M8×110	SC	100	HX189895	M14×55	SC	50
HX523590	M14×130	BZP/C	25	HX373034	M8×120	SC	100	HX189901	M14×60	SC	50
IC353456	M16×45	BZP/C	50	HX373041	M8×130	SC	100	HX189918	M14×65	SC	50
HX373508	M16×50	BZP/C	50	HX373058	M8×140	SC	100	HX189925	M14×70	SC	50
HX373515	M16×55	BZP/C	50	HX373065	M8×160	SC	100	HX189932	M14×75	SC	50
HX373522	M16×60	BZP/C	50	HX373072	M8×180	SC	100	HX373423	M14×80	SC	50
HX373539	M16×70	BZP/C	50	HX373089	M10×35	SC	100	HX189956	M14×90	SC	50
HX373553	M16×80	BZP/C	25	HX189550	M10×40	SC	100	HX189963	M14×100	SC	25
HX373577	M16×90	BZP/C	25	HX189567	M10×45	SC	100	HX189970	M14×110	SC	25
HX373584	M16×100	BZP/C	25	HX189574	M10×50	SC	100	HX373461	M14×120	SC	25
IC314921	M16×110	BZP/C	25	HX189581	M10×55	SC	100	HX189994	M14×130	SC	25
IC316451	M16×120	BZP/C	100	HX189628	M10×60	SC	100	HX373478	M14×140	SC	25
IC355528	M18×60	BZP/C	25	HX189635	M10×65	SC	100	HX190006	M16×45	SC	50
HX373850	M20×60	BZP/C	25	HX189642	M10×70	SC	100	HX190013	M16×50	SC	50
HX373874	M20×70	BZP/C	25	HX373133	M10×75	SC	100	HX190020	M16×55	SC	50
HX373904	M20×80	BZP/C	25	HX189659	M10×80	SC	100	HX190037	M16×60	SC	50
HX373911	M20×90	BZP/C	25	HX373164	M10×90	SC	50	HX190044	M16×65	SC	50
HX373928	M20×100	BZP/C	25	HX189666	M10×100	SC	50	HX190051	M16×70	SC	50
HX373942	M20×120	BZP/C	25	HX373188	M10×110	SC	50	HX190068	M16×75	SC	50
HX373966	M20×130	BZP/C	25	HX189680	M10×130	SC	50	HX190075	M16×80	SC	25
HX374161	M24×60	BZP/C	25	HX373195	M10×140	SC	50	HX373560	M16×85	SC	25
				HX189703	M10×150	SC	50	HX190082	M16×90	SC	25



Article No.	Size	Finish	Box Qty.
HX190099	M16×100	SC	25
HX190105	M16×110	SC	25
HX190112	M16×120	SC	25
HX190129	M16×130	SC	25
HX190136	M16×140	SC	25
HX190143	M16×150	SC	25
HX373591	M16×160	SC	25
HX373607	M16×170	SC	25
HX373614	M16×180	SC	25
HX373621	M16×190	SC	25
HX373638	M16×200	SC	25
HX373652	M16×220	SC	25
HX373706	M18×60	SC	25
HX373713	M18×65	SC	25
HX373720	M18×70	SC	25
HX373737	M18×75	SC	25
HX373744	M18×80	SC	25
HX373751	M18×90	SC	25
HX373782	M18×120	SC	25
HX373805	M18×140	SC	25
HX373812	M18×150	SC	25
HX190150	M20×60	SC	25
HX373867	M20×65	SC	25
HX190174	M20×70	SC	25
HX373881	M20×75	SC	25
HX190198	M20×80	SC	25
HX190204	M20×90	SC	25
HX190211	M20×100	SC	25
HX190228	M20×110	SC	25
HX190235	M20×120	SC	25
HX373959	M20×130	SC	25
HX190259	M20×140	SC	25
HX190266	M20×150	SC	25
HX190273	M20×160	SC	25
HX373973	M20×170	SC	25
HX190280	M20×180	SC	25
HX373980	M20×190	SC	25
HX190297	M20×200	SC	25
HX373997	M20×210	SC	25
HX374000	M20×220	SC	25
HX374017	M20×240	SC	25
HX374055	M22×65	SC	25
HX374062	M22×70	SC	25

HX374079	M22×75	SC	25
HX374086	M22×80	SC	25
HX374093	M22×90	SC	25
HX374109	M22×100	SC	25
HX374116	M22×110	SC	25
HX374130	M22×130	SC	25
HX374147	M22×140	SC	25
HX374154	M22×150	SC	25
HX190303	M24×60	SC	25
HX190310	M24×70	SC	25
HX374192	M24×75	SC	25
HX190327	M24×80	SC	25
HX190334	M24×90	SC	25
HX190341	M24×100	SC	25
HX374246	M24×110	SC	25
HX374253	M24×120	SC	25
HX190372	M24×130	SC	25
HX190389	M24×140	SC	25
HX190396	M24×150	SC	25
HX190402	M24×160	SC	25
HX190419	M24×170	SC	15
HX190426	M24×180	SC	25
HX374260	M24×190	SC	25
HX190433	M24×200	SC	25
HX374291	M24×240	SC	25
HX374307	M24×250	SC	25
HX374314	M24×260	SC	25
HX374321	M24×280	SC	25
HX374352	M27×90	SC	10
HX374369	M27×100	SC	10
HX374383	M27×120	SC	10
HX374420	M27×160	SC	10
HX374444	M27×200	SC	10
HX190440	M30×100	SC	10
HX190457	M30×110	SC	10
HX374468	M30×120	SC	10
HX374475	M30×130	SC	10
HX190488	M30×140	SC	10
HX190495	M30×150	SC	10
HX190501	M30×160	SC	10
HX374482	M30×180	SC	10
HX374505	M30×200	SC	10

HX374512	M30×220	SC	10
HX374529	M30×240	SC	10
HX374604	M36×150	SC	5

> High Tensile Hexagon Bolts & Sets Metric Thread

Hexagon Bolts Fine Pitch DIN 960 ISO 898-1 Self Colour Grade 10.9

A higher tensile strength than grade 8.8

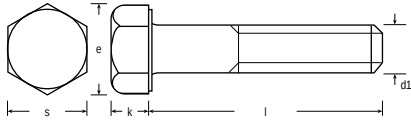

d1	M10 1.25 PITCH	M12 1.25 PITCH	M12 1.50 PITCH	M14 1.50 PITCH	M16 1.50 PITCH	M18 1.50 PITCH	M20 1.50 PITCH	M24 2.00 PITCH
e	18.9	21.1	21.1	24.49	26.75	30.14	33.53	39.98
k	6.4	7.5	7.5	8.8	10	11.5	12.5	15
s	17	19	19	22	24	27	30	36

Product Codes Begin **Q10960F** Product Group **10**

Article No.	Size	Pitch	Box Qty.
HX377896	M12 × 40	(1.25P)	100
HX377346	M12 × 45	(1.50P)	100
HX377919	M12 × 50	(1.25P)	100
HX377353	M12 × 50	(1.50P)	100
HX377933	M12 × 70	(1.25P)	50
HX377940	M12 × 80	(1.25P)	50
HX377988	M12 × 120	(1.25P)	50
HX377414	M14 × 50	(1.50P)	50
HX377421	M14 × 55	(1.50P)	50
HX377476	M14 × 100	(1.50P)	50
HX377483	M16 × 50	(1.50P)	50
HX377490	M16 × 55	(1.50P)	50
HX377506	M16 × 60	(1.50P)	50
HX377513	M16 × 65	(1.50P)	25
HX377520	M16 × 70	(1.50P)	25

HX377537	M16 × 75	(1.50P)	25
HX377544	M16 × 80	(1.50P)	25
HX377551	M16 × 90	(1.50P)	25
HX377568	M16 × 100	(1.50P)	25
HX377599	M16 × 120	(1.50P)	25
HX377674	M18 × 90	(1.50P)	25
HX377704	M20 × 60	(1.50P)	25
HX377728	M20 × 70	(1.50P)	25
HX377735	M20 × 80	(1.50P)	25
HX377742	M20 × 90	(1.50P)	25
HX377759	M20 × 100	(1.50P)	25
HX377766	M20 × 110	(1.50P)	25
HX377827	M24 × 90	(2.00P)	10
HX377872	M24 × 140	(2.00P)	10

Hexagon Bolts DIN 931 ISO 898-1 Self Colour Grade 12.9

A higher tensile strength than grade 10.9

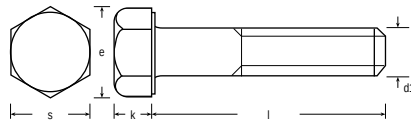

d1	M8	M10	M12	M16	M20	M24
e	14.38	18.9	21.1	26.75	33.53	39.98
k	5.3	6.4	7.5	10	12.5	15
s	13	17	19	24	30	36

Product Codes Begin **Q12931** Product Group **10**

Article No.	Size	Box Qty.
HX376165	M8 × 40	100
HX376202	M10 × 40	100
HX376219	M10 × 50	100
HX376226	M10 × 60	100
HX376240	M10 × 80	100
HX376257	M10 × 90	100
HX376271	M12 × 50	100
HX376288	M12 × 60	100
HX376295	M12 × 65	50
HX376301	M12 × 70	50
HX376318	M12 × 75	50
HX376325	M12 × 80	50
HX376332	M12 × 90	50

HX376349	M12 × 100	50
HX376356	M12 × 110	50
HX376363	M12 × 120	50
IC359250	M12 × 130	50
HX376387	M14 × 80	50
HX376394	M16 × 55	50
HX376400	M16 × 60	50
HX376417	M16 × 65	25
HX376424	M16 × 70	25
HX376431	M16 × 75	25
HX376448	M16 × 80	25
HX376455	M16 × 90	25
HX376462	M16 × 100	25

HX376479	M16 × 110	25
HX376486	M16 × 120	25
HX376493	M16 × 130	25
HX376509	M16 × 140	25
HX376516	M16 × 150	25
HX376523	M16 × 160	25
HX376530	M20 × 60	25
HX376547	M20 × 65	25
HX376554	M20 × 70	25
IC357836	M20 × 80	50
HX376585	M20 × 90	25
HX376592	M20 × 100	25
HX376608	M20 × 110	25

HX376615	M20 × 120	25
HX376622	M20 × 130	25
HX376639	M20 × 140	25
HX376646	M20 × 150	25
HX376653	M20 × 160	25
HX376660	M24 × 75	25
HX376677	M24 × 80	25
HX376684	M24 × 90	10
HX376691	M24 × 100	10
HX376707	M24 × 110	10
HX376714	M24 × 120	10
HX376738	M24 × 140	10
HX376745	M24 × 150	10



Developed by our Technical Department, the JCP Anchor Specification Programme has recently been improved to include 3D graphics, along with hole depth optimisation for chemical anchors.

It has the facility to calculate numerous configurations of fixings in different base plate geometry. Calculations are carried out in accordance with the current European Guide EOTA TR 029 for bonded anchors and EOTA ETAG-001 ANNEX C for mechanical anchors.

The software and data base are updated regularly to ensure the programme is compliant with any changes in legislation, or industry standards.

The JCP Anchor Calculation Programme is free to download via www.jcpfixings.co.uk

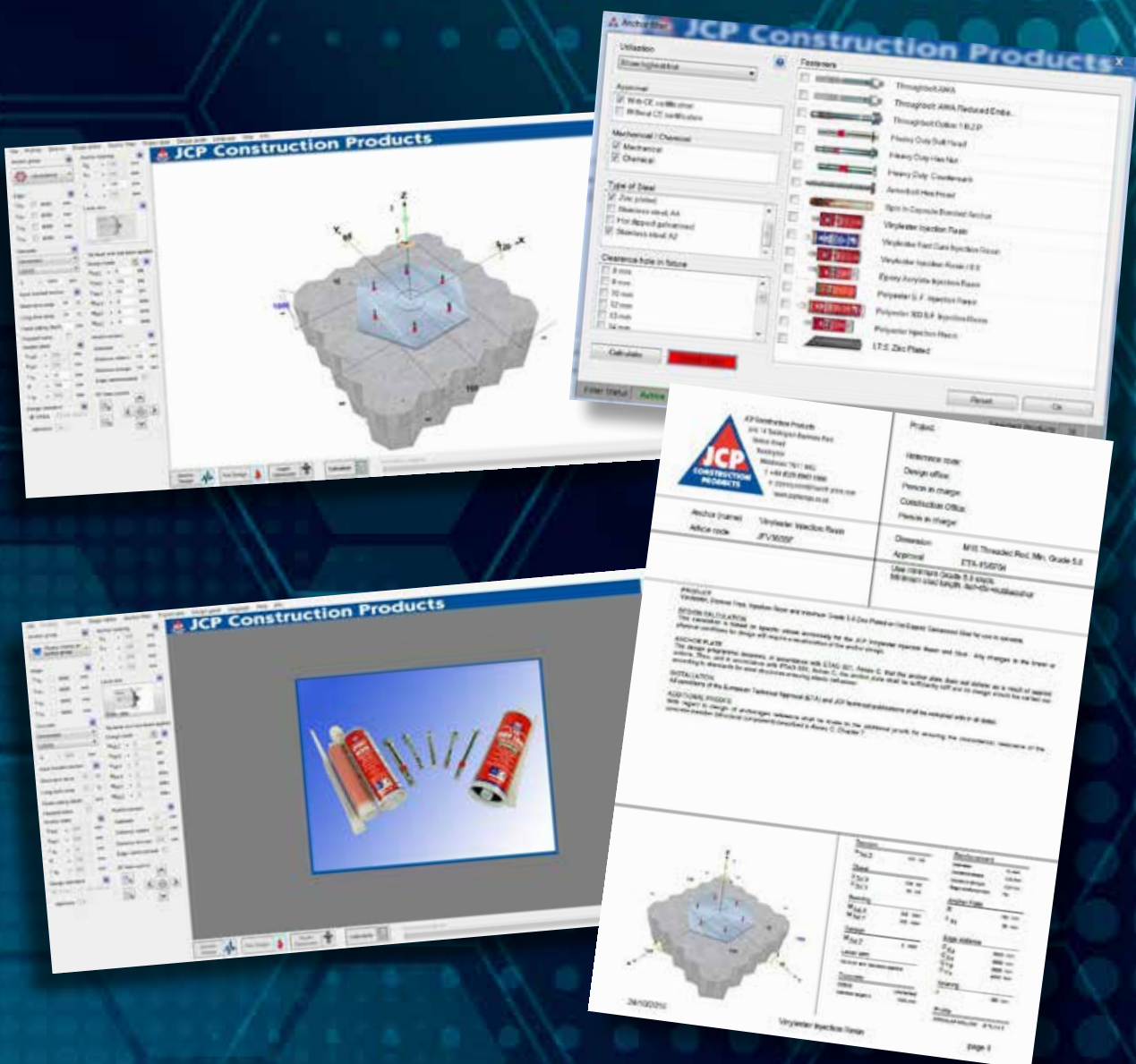

High Tensile Hexagon Bolts & Sets Metric Thread

Hexagon Set Screws DIN 933 ISO 898-1 Grade 8.8

All fully threaded

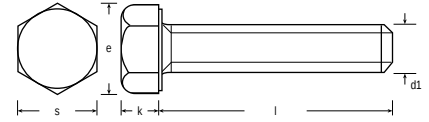

d1	M4	M5	M6	M8	M10	M12	M14	M16	M18	M20	M22	M24	M30	M33
e	7.66	8.79	11.05	14.38	18.9	21.1	24.49	26.75	30.14	35.72	35.72	39.98	50.85	55.37
k	2.8	3.5	4.0	5.3	6.4	7.5	8.8	10	11.5	13	14	15	18.7	21
s	7	8	10	13	17	19	22	24	27	30	34	36	46	50

Product Codes Begin &MHS Product Group 3

Article No.	Size	Finish	Box Qty.											
OJ303697	M4 × 10	BZP	500	OJ526324	M8 × 140	BZP	50	OJ242408	M16 × 40	BZP	50			
OJ303710	M4 × 12	BZP	500	OJ422169	M8 × 150	BZP	50	OJ242415	M16 × 45	BZP	50			
OJ303727	M4 × 16	BZP	500	OJ213903	M10 × 12	BZP	200	OJ242422	M16 × 50	BZP	50			
OJ303734	M4 × 20	BZP	500	OJ304847	M10 × 16	BZP	200	OJ242439	M16 × 55	BZP	50			
OJ303741	M4 × 25	BZP	500	OJ304878	M10 × 20	BZP	200	OJ242446	M16 × 60	BZP	50			
OJ303758	M4 × 30	BZP	500	OJ024219	M10 × 25	BZP	200	OJ144894	M16 × 65	BZP	25			
OJ303765	M4 × 35	BZP	500	OJ508313	M10 × 30	BZP	200	OJ242453	M16 × 70	BZP	25			
OJ303772	M4 × 40	BZP	500	OJ024226	M10 × 35	BZP	100	OJ144313	M16 × 75	BZP	25			
OJ303789	M4 × 50	BZP	500	OJ508320	M10 × 40	BZP	100	OJ305899	M16 × 80	BZP	25			
OJ303796	M5 × 8	BZP	500	OJ304984	M10 × 45	BZP	100	OJ305912	M16 × 90	BZP	25			
OJ303802	M5 × 10	BZP	500	OJ508337	M10 × 50	BZP	100	OJ144320	M16 × 100	BZP	25			
OJ303826	M5 × 12	BZP	500	OJ305028	M10 × 55	BZP	100	OJ422220	M16 × 110	BZP	25			
OJ303840	M5 × 16	BZP	500	OJ508344	M10 × 60	BZP	100	OJ422237	M16 × 120	BZP	25			
OJ303871	M5 × 20	BZP	500	OJ213910	M10 × 65	BZP	100	OJ422244	M16 × 130	BZP	20			
OJ303895	M5 × 25	BZP	500	OJ305073	M10 × 70	BZP	100	OJ422251	M16 × 140	BZP	20			
OJ303918	M5 × 30	BZP	500	OJ305103	M10 × 75	BZP	100	OJ422268	M16 × 150	BZP	20			
OJ303949	M5 × 35	BZP	200	OJ305134	M10 × 80	BZP	100	OJ422275	M16 × 160	BZP	10			
OJ303956	M5 × 40	BZP	200	OJ305165	M10 × 90	BZP	100	OJ422282	M16 × 200	BZP	10			
OJ303970	M5 × 50	BZP	200	OJ305189	M10 × 100	BZP	100	OJ422299	M18 × 50	BZP	25			
OJ303994	M5 × 60	BZP	200	OJ213927	M10 × 120	BZP	50	OJ422305	M18 × 100	BZP	20			
OJ304014	M6 × 10	BZP	500	OJ422176	M10 × 130	BZP	50	OJ213958	M20 × 30	BZP	25			
OJ304045	M6 × 12	BZP	500	OJ526256	M10 × 140	BZP	50	OJ422312	M20 × 35	BZP	25			
OJ304076	M6 × 16	BZP	500	OJ422183	M10 × 150	BZP	50	OJ024370	M20 × 40	BZP	25			
OJ304106	M6 × 20	BZP	500	OJ213934	M12 × 16	BZP	100	OJ024387	M20 × 45	BZP	25			
OJ304137	M6 × 25	BZP	500	OJ305202	M12 × 20	BZP	100	OJ242460	M20 × 50	BZP	25			
OJ304168	M6 × 30	BZP	500	OJ024233	M12 × 25	BZP	100	OJ024400	M20 × 55	BZP	25			
OJ304199	M6 × 35	BZP	200	OJ024240	M12 × 30	BZP	100	OJ242477	M20 × 60	BZP	25			
OJ304229	M6 × 40	BZP	200	OJ024257	M12 × 35	BZP	100	OJ306032	M20 × 65	BZP	25			
OJ304243	M6 × 45	BZP	200	OJ024264	M12 × 40	BZP	100	OJ024424	M20 × 70	BZP	25			
OJ304267	M6 × 50	BZP	200	OJ024271	M12 × 45	BZP	100	OJ144344	M20 × 75	BZP	25			
OJ304281	M6 × 55	BZP	200	OJ508375	M12 × 50	BZP	100	OJ306087	M20 × 80	BZP	25			
OJ304304	M6 × 60	BZP	200	OJ305356	M12 × 55	BZP	100	OJ306117	M20 × 90	BZP	25			
OJ213873	M6 × 65	BZP	200	OJ242392	M12 × 60	BZP	100	OJ144351	M20 × 100	BZP	25			
OJ304335	M6 × 70	BZP	200	OJ144245	M12 × 65	BZP	50	OJ136240	M22 × 50	BZP	25			
OJ304359	M6 × 75	BZP	200	OJ305400	M12 × 70	BZP	50	OJ136257	M22 × 60	BZP	25			
OJ304373	M6 × 80	BZP	100	OJ144252	M12 × 75	BZP	50	OJ136264	M22 × 70	BZP	25			
OJ213880	M6 × 90	BZP	100	OJ305448	M12 × 80	BZP	50	OJ136271	M22 × 80	BZP	25			
OJ213897	M6 × 100	BZP	100	OJ305479	M12 × 90	BZP	50	OJ136288	M22 × 90	BZP	25			
OJ304403	M8 × 10	BZP	200	OJ144269	M12 × 100	BZP	50	OJ136295	M22 × 100	BZP	25			
OJ304410	M8 × 12	BZP	200	OJ305509	M12 × 120	BZP	50	OJ306193	M24 × 50	BZP	25			
OJ304441	M8 × 16	BZP	200	OJ422190	M12 × 130	BZP	25	OJ213965	M24 × 55	BZP	25			
OJ304472	M8 × 20	BZP	200	OJ526263	M12 × 140	BZP	25	OJ306223	M24 × 60	BZP	25			
OJ304502	M8 × 25	BZP	200	OJ422206	M12 × 150	BZP	25	OJ306247	M24 × 65	BZP	25			
OJ508269	M8 × 30	BZP	200	OJ359052	M12 × 160	BZP	25	OJ306261	M24 × 70	BZP	25			
OJ304557	M8 × 35	BZP	200	OJ422213	M12 × 200	BZP	25	OJ306285	M24 × 75	BZP	25			
OJ304588	M8 × 40	BZP	200	OJ305530	M14 × 30	BZP	100	OJ306308	M24 × 80	BZP	25			
OJ121222	M8 × 45	BZP	200	OJ305547	M14 × 35	BZP	100	OJ306322	M24 × 90	BZP	10			
OJ508283	M8 × 50	BZP	200	OJ305561	M14 × 40	BZP	100	OJ306346	M24 × 100	BZP	10			
OJ304625	M8 × 55	BZP	200	OJ305578	M14 × 45	BZP	50	OJ136301	M24 × 120	BZP	10			
OJ304649	M8 × 60	BZP	200	OJ305592	M14 × 50	BZP	50	OJ136318	M30 × 60	BZP	5			
OJ304670	M8 × 65	BZP	200	OJ305608	M14 × 55	BZP	50	OJ136332	M30 × 65	BZP	5			
OJ304694	M8 × 70	BZP	200	OJ305622	M14 × 60	BZP	50	OJ136349	M30 × 70	BZP	5			
OJ304724	M8 × 75	BZP	200	OJ305646	M14 × 70	BZP	50	OJ136356	M30 × 75	BZP	5			
OJ304755	M8 × 80	BZP	200	OJ305660	M14 × 80	BZP	50	OJ136363	M30 × 80	BZP	5			
OJ304786	M8 × 90	BZP	100	OJ213941	M14 × 100	BZP	50	OJ136370	M30 × 90	BZP	5			
OJ304809	M8 × 100	BZP	100	OJ305691	M16 × 25	BZP	50	OJ136387	M30 × 100	BZP	5			
OJ422152	M8 × 120	BZP	100	OJ024295	M16 × 30	BZP	50	OJ136394	M30 × 120	BZP	5			
OJ526300	M8 × 130	BZP	50	OJ024301	M16 × 35	BZP	50	OJ280806	M10 × 20	HDG	200			



Article No. Size Finish Box Qty

OJ263175	M10 x 25	HDG	200
OJ676845	M10 x 30	HDG	200
OJ263182	M10 x 35	HDG	100
OJ270739	M10 x 40	HDG	100
OJ270746	M10 x 50	HDG	100
OJ280813	M10 x 100	HDG	100
OJ156958	M12 x 20	HDG	100
OJ156965	M12 x 25	HDG	100
OJ148816	M12 x 30	HDG	100
OJ148823	M12 x 35	HDG	100
OJ148830	M12 x 40	HDG	100
OJ157009	M12 x 45	HDG	100
OJ157016	M12 x 50	HDG	100
OJ157023	M12 x 60	HDG	100
OJ280820	M12 x 65	HDG	50
OJ157030	M12 x 70	HDG	50
OJ157047	M12 x 80	HDG	100
OJ280837	M12 x 90	HDG	50
OJ157054	M12 x 100	HDG	50
OJ148847	M16 x 30	HDG	50
OJ148854	M16 x 35	HDG	50
OJ148861	M16 x 40	HDG	50
OJ148878	M16 x 45	HDG	50
OJ148885	M16 x 50	HDG	50
OJ157115	M16 x 55	HDG	50
OJ157122	M16 x 60	HDG	50
OJ157139	M16 x 65	HDG	25
OJ157146	M16 x 70	HDG	25
OJ157153	M16 x 75	HDG	25
OJ157160	M16 x 80	HDG	25
OJ157177	M16 x 90	HDG	25
OJ157184	M16 x 100	HDG	25
OJ280844	M16 x 110	HDG	25
OJ280851	M16 x 120	HDG	25
OJ280868	M20 x 30	HDG	25
OJ157207	M20 x 40	HDG	25
OJ148892	M20 x 45	HDG	25
OJ148908	M20 x 50	HDG	25
OJ148915	M20 x 55	HDG	25
OJ148922	M20 x 60	HDG	25
OJ148939	M20 x 65	HDG	25
OJ148946	M20 x 70	HDG	25
OJ157290	M20 x 75	HDG	25
OJ157306	M20 x 80	HDG	25
OJ157313	M20 x 90	HDG	25
OJ157320	M20 x 100	HDG	25
OJ280875	M20 x 120	HDG	25
OJ157337	M24 x 50	HDG	25
OJ280882	M24 x 55	HDG	25
OJ148953	M24 x 60	HDG	25
OJ157368	M24 x 65	HDG	25
OJ148960	M24 x 70	HDG	25
OJ148977	M24 x 80	HDG	25
OJ157399	M24 x 90	HDG	10
OJ157405	M24 x 100	HDG	10
OJ676852	M30 x 90	HDG	5
OJ676869	M30 x 100	HDG	5
OJ304007	M6 x 10	SC	500
OJ304038	M6 x 12	SC	500
OJ304069	M6 x 16	SC	500

OJ304090	M6 x 20	SC	500
OJ304120	M6 x 25	SC	500
OJ304151	M6 x 30	SC	500
OJ304182	M6 x 35	SC	200
OJ304212	M6 x 40	SC	200
OJ304250	M6 x 50	SC	200
OJ304298	M6 x 60	SC	200
OJ304342	M6 x 75	SC	200
OJ136226	M8 x 12	SC	200
OJ304434	M8 x 16	SC	200
OJ304465	M8 x 20	SC	200
OJ304496	M8 x 25	SC	200
OJ304526	M8 x 30	SC	200
OJ304540	M8 x 35	SC	200
OJ304571	M8 x 40	SC	200
OJ136233	M8 x 45	SC	200
OJ304601	M8 x 50	SC	200
OJ213484	M8 x 55	SC	200
OJ304632	M8 x 60	SC	200
OJ304663	M8 x 65	SC	200
OJ304687	M8 x 70	SC	200
OJ304717	M8 x 75	SC	200
OJ304748	M8 x 80	SC	200
OJ304793	M8 x 100	SC	100
OJ213491	M8 x 120	SC	100
OJ304823	M10 x 12	SC	200
OJ304830	M10 x 16	SC	200
OJ304861	M10 x 20	SC	200
OJ304892	M10 x 25	SC	200
OJ304915	M10 x 30	SC	200
OJ304939	M10 x 35	SC	100
OJ304953	M10 x 40	SC	100
OJ304977	M10 x 45	SC	100
OJ305004	M10 x 50	SC	100
OJ305035	M10 x 60	SC	100
OJ305059	M10 x 65	SC	100
OJ305066	M10 x 70	SC	100
OJ305097	M10 x 75	SC	100
OJ305127	M10 x 80	SC	100
OJ305158	M10 x 90	SC	100
OJ305172	M10 x 100	SC	100
OJ213521	M10 x 120	SC	50
OJ213545	M10 x 150	SC	50
OJ305196	M12 x 20	SC	100
OJ305226	M12 x 25	SC	100
OJ305240	M12 x 30	SC	100
OJ305264	M12 x 35	SC	100
OJ305288	M12 x 40	SC	100
OJ305301	M12 x 45	SC	100
OJ305325	M12 x 50	SC	100
OJ305349	M12 x 55	SC	100
OJ305363	M12 x 60	SC	100
OJ305387	M12 x 65	SC	50
OJ305394	M12 x 70	SC	50
OJ305424	M12 x 75	SC	50
OJ305431	M12 x 80	SC	50
OJ305462	M12 x 90	SC	50
OJ305486	M12 x 100	SC	50
OJ305493	M12 x 120	SC	50
OJ213552	M12 x 130	SC	50

OJ213576	M12 x 200	SC	25
OJ213590	M14 x 40	SC	100
OJ213606	M14 x 45	SC	50
OJ213613	M14 x 50	SC	50
OJ305684	M16 x 25	SC	50
OJ305714	M16 x 30	SC	50
OJ305721	M16 x 35	SC	50
OJ305745	M16 x 40	SC	50
OJ305769	M16 x 45	SC	50
OJ305783	M16 x 50	SC	50
OJ305806	M16 x 55	SC	50
OJ305820	M16 x 60	SC	50
OJ305844	M16 x 65	SC	25
OJ305851	M16 x 70	SC	25
OJ305875	M16 x 75	SC	25
OJ305882	M16 x 80	SC	25
OJ305905	M16 x 90	SC	25
OJ305929	M16 x 100	SC	25
OJ305936	M16 x 120	SC	25
OJ213682	M18 x 50	SC	25
OJ213705	M20 x 30	SC	25
OJ213712	M20 x 35	SC	25
OJ305943	M20 x 40	SC	25
OJ305950	M20 x 45	SC	25
OJ305974	M20 x 50	SC	25
OJ305998	M20 x 55	SC	25
OJ306001	M20 x 60	SC	25
OJ306025	M20 x 65	SC	25
OJ306049	M20 x 70	SC	25
OJ306063	M20 x 75	SC	25
OJ306070	M20 x 80	SC	25
OJ306100	M20 x 90	SC	25
OJ306124	M20 x 100	SC	25
OJ213729	M20 x 110	SC	25
OJ306131	M20 x 120	SC	25
OJ213736	M20 x 130	SC	10
OJ213767	M20 x 180	SC	10
OJ306179	M24 x 40	SC	25
OJ306186	M24 x 50	SC	25
OJ306216	M24 x 60	SC	25
OJ306230	M24 x 65	SC	25
OJ306254	M24 x 70	SC	25
OJ306278	M24 x 75	SC	25
OJ306292	M24 x 80	SC	25
OJ306315	M24 x 90	SC	10
OJ306339	M24 x 100	SC	10
OJ306360	M24 x 120	SC	10
OJ213781	M24 x 150	SC	10
OJ213798	M30 x 50	SC	10
OJ213804	M30 x 60	SC	5
OJ213828	M30 x 80	SC	5
OJ213835	M30 x 90	SC	5
OJ213842	M30 x 100	SC	5
OJ213859	M30 x 120	SC	5
OJ213866	M30 x 130	SC	5
OJ283722	M33 x 200	SC	5

> High Tensile Hexagon Bolts & Sets Metric Thread

Hexagon Sets DIN 933 ISO 898-1 Grade 10.9

All fully threaded. A higher tensile strength than grade 8.8.

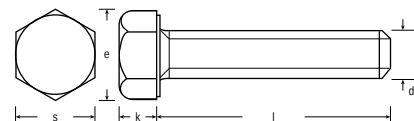

d1	M6	M8	M10	M12	M14	M16	M18	M20	M22	M24	M30
e	11.05	14.38	18.9	21.1	24.49	26.75	30.14	35.72	35.72	39.98	50.85
k	4	5.3	6.4	7.5	8.8	10	11.5	13	14	15	18.7
s	10	13	17	19	22	24	27	30	34	36	46

Product Codes Begin **Q10933** Product Group **10**

Article No.	Size	Finish	Box Qty.										
HX374796	M8 × 20	BZP/C	200	HX190600	M8 × 30	SC	200	HX190860	M16 × 60	SC	50		
HX374802	M8 × 25	BZP/C	200	HX374826	M8 × 35	SC	200	HX190877	M16 × 65	SC	50		
HX374833	M8 × 35	BZP/C	200	HX374864	M8 × 50	SC	100	HX190884	M16 × 70	SC	25		
HX374932	M10 × 25	BZP/C	200	HX374901	M8 × 70	SC	100	HX375458	M16 × 75	SC	25		
HX374949	M10 × 30	BZP/C	200	HX190631	M10 × 20	SC	200	HX240541	M16 × 80	SC	25		
HX374963	M10 × 35	BZP/C	100	HX190648	M10 × 25	SC	200	HX375472	M16 × 90	SC	25		
HX374970	M10 × 40	BZP/C	100	HX190655	M10 × 30	SC	200	HX375496	M16 × 100	SC	25		
HX374987	M10 × 45	BZP/C	100	HX374956	M10 × 35	SC	100	HX375526	M16 × 130	SC	25		
HX374994	M10 × 50	BZP/C	100	HX190679	M10 × 40	SC	100	HX375533	M16 × 140	SC	25		
HX375076	M12 × 20	BZP/C	200	HX190686	M10 × 45	SC	100	HX375540	M16 × 150	SC	25		
HX375090	M12 × 30	BZP/C	200	HX190693	M10 × 50	SC	100	HX375564	M18 × 40	SC	50		
HX375106	M12 × 35	BZP/C	100	HX375014	M10 × 60	SC	100	HX375588	M18 × 50	SC	50		
HX375113	M12 × 40	BZP/C	100	HX375045	M10 × 90	SC	100	HX375618	M18 × 60	SC	25		
HX375144	M12 × 50	BZP/C	100	HX375069	M12 × 20	SC	200	HX375649	M18 × 80	SC	25		
HX375274	M14 × 40	BZP/C	100	HX190709	M12 × 25	SC	200	HX375670	M20 × 40	SC	50		
HX375281	M14 × 45	BZP/C	100	HX190716	M12 × 30	SC	200	HX375687	M20 × 45	SC	25		
HX375298	M14 × 50	BZP/C	100	HX190723	M12 × 35	SC	100	HX190914	M20 × 50	SC	25		
HX375380	M16 × 40	BZP/C	50	HX190730	M12 × 40	SC	100	HX190921	M20 × 55	SC	25		
HX375397	M16 × 45	BZP/C	50	HX375120	M12 × 45	SC	100	HX190938	M20 × 60	SC	25		
HX375403	M16 × 50	BZP/C	50	HX190754	M12 × 50	SC	100	HX190945	M20 × 65	SC	25		
HX375410	M16 × 55	BZP/C	50	HX375151	M12 × 55	SC	100	HX375731	M20 × 70	SC	25		
HX375465	M16 × 80	BZP/C	25	HX190761	M14 × 30	SC	100	HX190969	M20 × 75	SC	25		
HX375595	M18 × 50	BZP/C	50	HX375250	M14 × 35	SC	100	HX190976	M20 × 80	SC	25		
HX375700	M20 × 55	BZP/C	25	HX190778	M14 × 40	SC	100	HX190983	M20 × 90	SC	25		
HX375939	M24 × 60	BZP/C	25	HX190785	M14 × 45	SC	100	HX375779	M20 × 100	SC	25		
HX374727	M6 × 12	SC	200	HX190792	M14 × 50	SC	100	HX375786	M20 × 110	SC	25		
HX190532	M6 × 16	SC	200	HX375311	M14 × 60	SC	50	HX375793	M20 × 120	SC	25		
HX190549	M6 × 20	SC	200	HX375342	M14 × 90	SC	50	HX375816	M20 × 140	SC	25		
HX190556	M6 × 25	SC	200	HX375359	M14 × 100	SC	25	HX191010	M24 × 50	SC	25		
HX190563	M6 × 30	SC	200	HX375373	M16 × 30	SC	100	HX191034	M24 × 60	SC	25		
HX374741	M6 × 35	SC	200	HX190815	M16 × 35	SC	50	HX191058	M24 × 70	SC	25		
HX374765	M8 × 12	SC	200	HX190822	M16 × 40	SC	50	HX191065	M24 × 75	SC	25		
HX190570	M8 × 16	SC	200	HX190839	M16 × 45	SC	50	HX375977	M24 × 80	SC	25		
HX190587	M8 × 20	SC	200	HX190846	M16 × 50	SC	50	HX376004	M24 × 100	SC	25		
HX190594	M8 × 25	SC	200	HX190853	M16 × 55	SC	50	HX376073	M30 × 70	SC	10		



Hexagon Sets Fine Pitch DIN 961 ISO 898-1 Grade 10.9

A higher tensile strength than grade 8.8

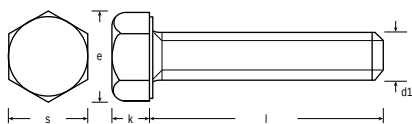

d1	M10	M10	M12	M12	M14	M16	M18	M20	M24
	1.00 PITCH	1.25 PITCH	1.50 PITCH	1.50 PITCH	1.50 PITCH	1.50 PITCH	1.50 PITCH	1.50 PITCH	2.00 PITCH
e	18.9	18.9	21.1	21.1	24.49	26.75	30.14	33.53	39.98
k	6.4	6.4	7.5	7.5	8.8	10	11.5	12.5	15
s	17	17	19	19	22	24	27	30	36

Product Codes Begin **Q10961** Product Group **10**

Article No.	Size	Pitch	Finish	Box Qty.
HX378008	M10×25	(1.25P)	SC	200
HX378015	M10×30	(1.25P)	SC	200
HX378466	M12×30	(1.25P)	SC	100
HX378473	M12×35	(1.25P)	SC	100
HX378480	M12×40	(1.25P)	SC	100
HX378077	M12×40	(1.50P)	SC	100
HX378084	M14×30	(1.50P)	SC	100
HX378114	M14×45	(1.50P)	SC	50

HX378121	M14×50	(1.50P)	SC	50
HX378176	M16×45	(1.50P)	SC	50
HX378190	M16×60	(1.50P)	SC	50
HX378275	M18×50	(1.50P)	SC	50
HX378329	M20×50	(1.50P)	SC	25
HX378336	M20×55	(1.50P)	SC	25
HX378398	M24×60	(2.00P)	SC	25

Hexagon Sets DIN 933 ISO 898-1 Grade 12.9

A higher tensile strength than grade 10.9

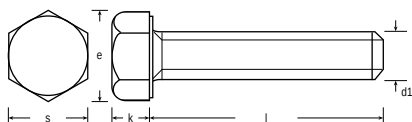

d1	M8	M10	M12	M14	M16	M20	M24
e	14.38	18.9	21.1	24.49	26.75	33.53	39.98
k	5.3	6.4	7.5	8.8	10	12.5	15
s	13	17	19	22	24	30	36

Product Codes Begin **Q12933** Product Group **10**

Article No.	Size	Finish	Box Qty.
HX376776	M8×20	SC	200
HX376783	M8×25	SC	200
HX376790	M8×30	SC	200
HX376813	M8×40	SC	200
HX376820	M8×50	SC	200
HX376837	M10×25	SC	200
HX376844	M10×30	SC	200
HX376851	M10×35	SC	100

HX376868	M10×40	SC	100
HX376882	M12×30	SC	100
HX376899	M12×35	SC	100
HX376905	M12×40	SC	100
HX376929	M12×50	SC	100
HX376974	M14×35	SC	100
HX376981	M14×40	SC	100
HX376998	M14×50	SC	50

HX377025	M16×45	SC	50
HX377032	M16×50	SC	50
HX377063	M20×50	SC	25
HX377070	M20×55	SC	25
HX377087	M20×60	SC	25
HX377094	M20×70	SC	25
HX377117	M20×90	SC	25
HX377124	M20×100	SC	25

> Hexagon Bolts & Sets Metric Thread

Brass Hexagon Set Screws DIN 933

All fully threaded

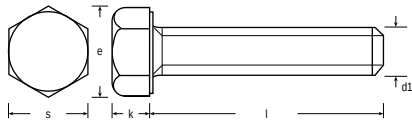

d1	M4	M5	M6	M8	M10	M12	M16
e	7.66	8.79	11.05	14.38	18.9	21.1	26.7
k	2.8	3.5	4.0	5.3	6.4	7.5	10.0
s	7.0	8.0	10.0	13.0	17.0	19.0	24.0

Product Codes Begin **Q60933** Product Group **3506**

Article No.	Size	Box Qty.	Article No.	Size	Box Qty.	Article No.	Size	Box Qty.
HX288635	M4 × 8	100	HX288819	M6 × 25	100	HX289007	M10 × 35	50
HX288642	M4 × 10	100	HX288826	M6 × 30	100	HX289014	M10 × 40	50
HX288659	M4 × 12	100	HX288833	M6 × 35	100	HX289021	M10 × 45	50
HX288666	M4 × 16	100	HX288840	M6 × 40	100	HX289038	M10 × 50	50
HX288673	M4 × 20	100	HX288857	M6 × 50	50	HX289052	M12 × 20	50
HX434223	M4 × 25	100	HX288864	M6 × 60	50	HX289069	M12 × 25	50
HX288697	M5 × 10	100	HX288888	M8 × 16	100	HX289076	M12 × 30	50
HX288703	M5 × 12	100	HX288895	M8 × 20	100	HX289083	M12 × 35	50
HX288710	M5 × 16	100	HX288901	M8 × 25	100	HX289090	M12 × 40	25
HX288727	M5 × 20	100	HX288918	M8 × 30	100	HX289106	M12 × 45	25
HX288734	M5 × 25	100	HX288925	M8 × 35	100	HX289113	M12 × 50	25
HX288741	M5 × 30	100	HX288932	M8 × 40	100	HX289120	M12 × 60	25
HX288758	M5 × 35	100	HX288949	M8 × 50	50	HX289137	M12 × 70	25
HX288765	M5 × 50	100	HX288956	M8 × 60	50	HX472775	M12 × 90	100
HX288772	M6 × 10	100	HX288963	M10 × 16	50	HX289144	M16 × 40	25
HX288789	M6 × 12	100	HX288970	M10 × 20	50	HX289151	M16 × 50	10
HX288796	M6 × 16	100	HX288987	M10 × 25	50	HX289168	M16 × 60	10
HX288802	M6 × 20	100	HX288994	M10 × 30	50	HX289182	M16 × 70	10



High Tensile Hexagon Bolts & Sets UNC Thread

Hexagon Bolts ANSI Grade 5

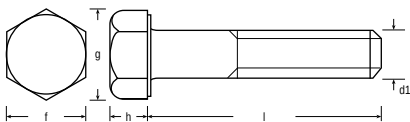

	d1	5/16" UNC	3/8" UNC	7/16" UNC	1/2" UNC	5/8" UNC	3/4" UNC	7/8" UNC	1" UNC
f max.		0.500	0.562	0.625	0.750	0.938	1.125	1.312	1.500
g max.		0.577	0.650	0.722	0.866	1.083	1.299	1.516	1.732
h max.		0.235	0.268	0.316	0.364	0.444	0.524	0.604	0.700

Product Codes Begin **&NCB** Product Group **3**

Article No.	Size	Finish	Box Qty.
OJ306377	5/16 - 18 UNC x 2	SC	200
OJ306391	5/16 - 18 UNC x 3	SC	200
OJ306407	5/16 - 18 UNC x 3.1/2	SC	100
OJ306414	5/16 - 18 UNC x 4	SC	100
OJ306421	3/8 - 16 UNC x 1.1/2	SC	100
OJ306438	3/8 - 16 UNC x 2	SC	100
OJ306452	3/8 - 16 UNC x 2.1/2	SC	100
OJ306469	3/8 - 16 UNC x 3	SC	100
OJ306476	3/8 - 16 UNC x 3.1/2	SC	100
OJ306483	3/8 - 16 UNC x 4	SC	100
OJ306490	3/8 - 16 UNC x 4.1/2	SC	50
OJ306506	3/8 - 16 UNC x 5	SC	50
OJ306513	7/16 - 14 UNC x 1.1/2	SC	100
OJ306520	7/16 - 14 UNC x 2	SC	100
OJ306537	7/16 - 14 UNC x 2.1/2	SC	100
OJ306544	7/16 - 14 UNC x 3	SC	100
OJ306551	7/16 - 14 UNC x 4	SC	50
OJ306568	7/16 - 14 UNC x 5	SC	50
OJ306575	1/2 - 13 UNC x 1.1/2	SC	100
OJ306582	1/2 - 13 UNC x 1.3/4	SC	100
OJ306599	1/2 - 13 UNC x 2	SC	100
OJ306612	1/2 - 13 UNC x 2.1/2	SC	50
OJ306629	1/2 - 13 UNC x 3	SC	50
OJ306636	1/2 - 13 UNC x 4	SC	50
OJ306643	1/2 - 13 UNC x 5	SC	25
OJ306681	5/8 - 11 UNC x 2	SC	50
OJ306698	5/8 - 11 UNC x 2.1/4	SC	50
OJ306704	5/8 - 11 UNC x 2.1/2	SC	25

OJ306711	5/8 - 11 UNC x 2.3/4	SC	25
OJ306728	5/8 - 11 UNC x 3	SC	50
OJ306742	5/8 - 11 UNC x 3.1/2	SC	25
OJ306759	5/8 - 11 UNC x 4	SC	25
OJ306766	5/8 - 11 UNC x 4.1/2	SC	25
OJ306773	5/8 - 11 UNC x 5	SC	25
OJ306797	5/8 - 11 UNC x 6	SC	25
OJ306803	5/8 - 11 UNC x 7	SC	25
OJ306834	3/4 - 10 UNC x 2.1/2	SC	25
OJ306858	3/4 - 10 UNC x 3	SC	50
OJ306865	3/4 - 10 UNC x 3.1/2	SC	25
OJ306872	3/4 - 10 UNC x 4	SC	20
OJ306889	3/4 - 10 UNC x 4.1/2	SC	25
OJ306896	3/4 - 10 UNC x 5	SC	25
OJ306902	3/4 - 10 UNC x 6	SC	25
OJ306926	3/4 - 10 UNC x 7	SC	10
OJ306971	7/8 - 9 UNC x 3	SC	25
OJ306988	7/8 - 9 UNC x 3.1/2	SC	25
OJ306995	7/8 - 9 UNC x 4	SC	40
OJ307022	7/8 - 9 UNC x 6	SC	10
OJ307046	1 - 8 UNC x 3.1/2	SC	5
OJ307053	1 - 8 UNC x 4	SC	15
OJ307060	1 - 8 UNC x 4.1/2	SC	10
OJ307077	1 - 8 UNC x 5	SC	10
OJ307084	1 - 8 UNC x 6	SC	5
OJ307091	1 - 8 UNC x 7	SC	5
OJ307107	1 - 8 UNC x 8	SC	10

High Tensile Hexagon Bolts & Sets UNC Thread

Hexagon Set Screws ANSI Grade 5

All fully threaded

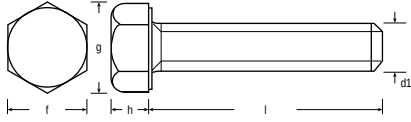

	d1	1/4 UNC	5/16 UNC	3/8 UNC	7/16 UNC	1/2 UNC	5/8 UNC	3/4 UNC	7/8 UNC	1 UNC
f	max.	0.438	0.500	0.562	0.625	0.750	0.938	1.125	1.312	1.500
g	max.	0.505	0.577	0.650	0.722	0.866	1.083	1.299	1.516	1.732
h	max.	0.188	0.235	0.268	0.316	0.364	0.444	0.524	0.604	0.700

Product Codes Begin **&NCS** Product Group **3**

Article No.	Size	Finish	Box Qty.				
OJ573625	1/4 - 20 UNC x 1/2	BZP	500	OJ307657	3/8 - 16 UNC x 2.1/2	SC	100
OJ307244	1/4 - 20 UNC x 3/4	BZP	500	OJ307664	3/8 - 16 UNC x 3	SC	100
OJ307275	1/4 - 20 UNC x 1	BZP	500	OJ307695	7/16 - 14 UNC x 1	SC	100
OJ307305	1/4 - 20 UNC x 1.1/2	BZP	200	OJ307701	7/16 - 14 UNC x 1.1/4	SC	100
OJ307336	1/4 - 20 UNC x 2	BZP	200	OJ307718	7/16 - 14 UNC x 1.1/2	SC	100
OJ573632	5/16 - 18 UNC x 3/4	BZP	200	OJ307732	7/16 - 14 UNC x 2	SC	100
OJ307411	5/16 - 18 UNC x 1	BZP	200	OJ307749	7/16 - 14 UNC x 2.1/2	SC	50
OJ307442	5/16 - 18 UNC x 1.1/2	BZP	200	OJ307770	1/2 - 13 UNC x 1	SC	100
OJ307473	5/16 - 18 UNC x 2	BZP	200	OJ307787	1/2 - 13 UNC x 1.1/4	SC	200
OJ307572	3/8 - 16 UNC x 1	BZP	200	OJ307794	1/2 - 13 UNC x 1.1/2	SC	100
OJ307602	3/8 - 16 UNC x 1.1/2	BZP	100	OJ307800	1/2 - 13 UNC x 1.3/4	SC	100
OJ307633	3/8 - 16 UNC x 2	BZP	100	OJ307817	1/2 - 13 UNC x 2	SC	100
OJ307213	1/4 - 20 UNC x 1/2	SC	500	OJ307831	1/2 - 13 UNC x 2.1/2	SC	50
OJ307237	1/4 - 20 UNC x 3/4	SC	500	OJ307848	1/2 - 13 UNC x 3	SC	50
OJ307268	1/4 - 20 UNC x 1	SC	500	OJ307886	5/8 - 11 UNC x 1	SC	50
OJ307282	1/4 - 20 UNC x 1.1/4	SC	500	OJ307893	5/8 - 11 UNC x 1.1/4	SC	100
OJ307299	1/4 - 20 UNC x 1.1/2	SC	200	OJ307909	5/8 - 11 UNC x 1.1/2	SC	50
OJ307329	1/4 - 20 UNC x 2	SC	200	OJ307923	5/8 - 11 UNC x 2	SC	50
OJ307374	5/16 - 18 UNC x 1/2	SC	200	OJ307947	5/8 - 11 UNC x 2.1/2	SC	25
OJ307381	5/16 - 18 UNC x 5/8	SC	200	OJ307954	5/8 - 11 UNC x 3	SC	25
OJ307398	5/16 - 18 UNC x 3/4	SC	200	OJ307978	5/8 - 11 UNC x 4	SC	25
OJ307404	5/16 - 18 UNC x 1	SC	200	OJ307992	3/4 - 10 UNC x 1.1/2	SC	25
OJ307428	5/16 - 18 UNC x 1.1/4	SC	200	OJ308005	3/4 - 10 UNC x 1.3/4	SC	25
OJ307435	5/16 - 18 UNC x 1.1/2	SC	200	OJ308012	3/4 - 10 UNC x 2	SC	25
OJ307466	5/16 - 18 UNC x 2	SC	200	OJ308029	3/4 - 10 UNC x 2.1/4	SC	25
OJ307534	3/8 - 16 UNC x 5/8	SC	200	OJ308036	3/4 - 10 UNC x 2.1/2	SC	25
OJ307541	3/8 - 16 UNC x 3/4	SC	200	OJ308043	3/4 - 10 UNC x 3	SC	25
OJ307565	3/8 - 16 UNC x 1	SC	200	OJ308067	3/4 - 10 UNC x 4	SC	25
OJ307589	3/8 - 16 UNC x 1.1/4	SC	200	OJ308081	7/8 - 9 UNC x 2	SC	10
OJ307596	3/8 - 16 UNC x 1.1/2	SC	100	OJ308098	7/8 - 9 UNC x 2.1/2	SC	10
OJ307619	3/8 - 16 UNC x 1.3/4	SC	100	OJ308128	1 - 8 UNC x 2.1/2	SC	5
OJ307626	3/8 - 16 UNC x 2	SC	100	OJ308135	1 - 8 UNC x 3	SC	5



High Tensile Hexagon Bolts & Sets UNF Thread

Hexagon Bolts ANSI Grade 5

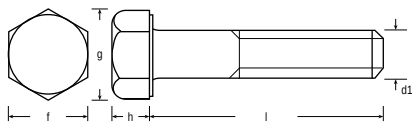

	d1	5/16" UNF	3/8" UNF	7/16" UNF	1/2" UNF	5/8" UNF	3/4" UNF	7/8" UNF	1" UNF
f	max.	0.500	0.562	0.625	0.750	0.938	1.125	1.312	1.500
g	max.	0.577	0.650	0.722	0.866	1.083	1.299	1.516	1.732
h	max.	0.235	0.268	0.313	0.364	0.444	0.524	0.604	0.700

Product Codes Begin **&NFB** Product Group **3**

Article No.	Size	Finish	Box Qty.
OJ308142	5/16 - 24 UNF x 1.1/2	SC	200
OJ308159	5/16 - 24 UNF x 2	SC	200
OJ308166	5/16 - 24 UNF x 2.1/2	SC	100
OJ308180	3/8 - 24 UNF x 1.1/2	SC	100
OJ308197	3/8 - 24 UNF x 2	SC	200
OJ308203	3/8 - 24 UNF x 2.1/2	SC	100
OJ308210	3/8 - 24 UNF x 3	SC	100
OJ308227	3/8 - 24 UNF x 3.1/2	SC	50
OJ308241	3/8 - 24 UNF x 4.1/2	SC	50
OJ308258	7/16 - 20 UNF x 1.1/2	SC	100
OJ308265	7/16 - 20 UNF x 1.3/4	SC	100
OJ308272	7/16 - 20 UNF x 2	SC	100
OJ308289	7/16 - 20 UNF x 2.1/2	SC	100
OJ308302	7/16 - 20 UNF x 3	SC	50
OJ308326	7/16 - 20 UNF x 3.1/2	SC	50
OJ308333	7/16 - 20 UNF x 4	SC	50
OJ308364	1/2 - 20 UNF x 1.1/2	SC	100
OJ308371	1/2 - 20 UNF x 2	SC	100
OJ308388	1/2 - 20 UNF x 2.1/2	SC	50
OJ308395	1/2 - 20 UNF x 3	SC	50
OJ308401	1/2 - 20 UNF x 3.1/2	SC	50
OJ308418	1/2 - 20 UNF x 4	SC	100
OJ308432	1/2 - 20 UNF x 5	SC	50

OJ308449	1/2 - 20 UNF x 6	SC	50
OJ308470	5/8 - 18 UNF x 2	SC	50
OJ308487	5/8 - 18 UNF x 2.1/4	SC	50
OJ308494	5/8 - 18 UNF x 2.1/2	SC	25
OJ308500	5/8 - 18 UNF x 3	SC	50
OJ308517	5/8 - 18 UNF x 3.1/2	SC	25
OJ308524	5/8 - 18 UNF x 4	SC	45
OJ308531	5/8 - 18 UNF x 4.1/2	SC	25
OJ308548	5/8 - 18 UNF x 5	SC	25
OJ308555	5/8 - 18 UNF x 6	SC	20
OJ308586	5/8 - 18 UNF x 8	SC	15
OJ308616	3/4 - 16 UNF x 2.1/2	SC	50
OJ308623	3/4 - 16 UNF x 3	SC	25
OJ308630	3/4 - 16 UNF x 3.1/2	SC	25
OJ308647	3/4 - 16 UNF x 4	SC	50
OJ308654	3/4 - 16 UNF x 4.1/2	SC	50
OJ308661	3/4 - 16 UNF x 5	SC	25
OJ308708	3/4 - 16 UNF x 7	SC	10
OJ308753	7/8 - 14 UNF x 4	SC	10
OJ308821	1 - 12 UNF x 4	SC	10
OJ308845	1 - 12 UNF x 5	SC	5
OJ308852	1 - 12 UNF x 6	SC	10

> High Tensile Hexagon Bolts & Sets UNF Thread

UNF Hexagon Set Screws ANSI Grade 5

All fully threaded

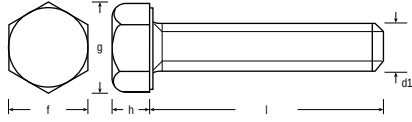

	d1	1/4" UNF	5/16" UNF	3/8" UNF	7/16" UNF	1/2" UNF	5/8" UNF	3/4" UNF
f	max.	0.438	0.500	0.562	0.625	0.750	0.938	1.125
g	max.	0.505	0.577	0.650	0.722	0.866	1.083	1.299
h	max.	0.188	0.235	0.268	0.316	0.364	0.444	0.524

Product Codes Begin **&NFS** Product Group **3**

Article No.	Size	Finish	Box Qty.
OJ573656	1/4 - 28 UNF x 1/2	BZP	500
OJ308937	1/4 - 28 UNF x 3/4	BZP	500
OJ308968	1/4 - 28 UNF x 1	BZP	500
OJ308999	5/16 - 24 UNF x 3/4	BZP	200
OJ309026	5/16 - 24 UNF x 1	BZP	200
OJ569116	5/16 - 24 UNF x 1.1/2	BZP	200
OJ136417	5/16 - 24 UNF x 2	BZP	200
OJ309101	3/8 - 24 UNF x 1	BZP	200
OJ309132	3/8 - 24 UNF x 1.1/2	BZP	100
OJ309156	3/8 - 24 UNF x 2	BZP	100
OJ308913	1/4 - 28 UNF x 5/8	SC	500
OJ308920	1/4 - 28 UNF x 3/4	SC	500
OJ308944	1/4 - 28 UNF x 7/8	SC	200
OJ308951	1/4 - 28 UNF x 1	SC	500
OJ308982	5/16 - 24 UNF x 3/4	SC	200
OJ309019	5/16 - 24 UNF x 1	SC	200
OJ309033	5/16 - 24 UNF x 1.1/4	SC	200
OJ569109	5/16 - 24 UNF x 1.1/2	SC	200
OJ309057	5/16 - 24 UNF x 2	SC	200
OJ309088	3/8 - 24 UNF x 3/4	SC	500
OJ309095	3/8 - 24 UNF x 1	SC	200
OJ309118	3/8 - 24 UNF x 1.1/4	SC	200
OJ309125	3/8 - 24 UNF x 1.1/2	SC	100
OJ309149	3/8 - 24 UNF x 2	SC	100
OJ309163	3/8 - 24 UNF x 3	SC	100
OJ309187	7/16 - 20 UNF x 3/4	SC	100
OJ309194	7/16 - 20 UNF x 1	SC	100
OJ309200	7/16 - 20 UNF x 1.1/4	SC	200
OJ309217	7/16 - 20 UNF x 1.1/2	SC	100
OJ309224	7/16 - 20 UNF x 2	SC	100
OJ309248	7/16 - 20 UNF x 3	SC	50
OJ309262	1/2 - 20 UNF x 1	SC	100
OJ309286	1/2 - 20 UNF x 1.1/2	SC	100
OJ309309	1/2 - 20 UNF x 2	SC	50
OJ309323	1/2 - 20 UNF x 3	SC	50
OJ309361	5/8 - 18 UNF x 1.1/2	SC	50
OJ309385	5/8 - 18 UNF x 2	SC	100
OJ309408	5/8 - 18 UNF x 3	SC	25
OJ309446	3/4 - 16 UNF x 2	SC	25
OJ309460	3/4 - 16 UNF x 2.1/2	SC	25



High Tensile Hexagon Bolts & Sets Whitworth Thread

Hexagon Bolts BS1083 Grade R

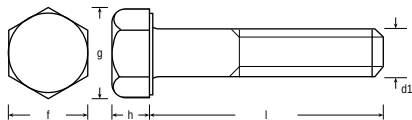

d1		1/2"	5/8"	3/4"
		BSW	BSW	BSW
f	max.	0.820	1.010	1.200
g	max.	0.950	1.170	1.390
h	max.	0.343	0.417	0.500

Product Codes Begin **&WHB** Product Group 3

Article No.	Size	Finish	Box Qty.				
OJ309552	1/2 x 1.1/2	SC	50	OJ309651	5/8 x 2.1/2	SC	25
OJ309576	1/2 x 2	SC	50	OJ309668	5/8 x 3	SC	25
OJ309606	1/2 x 3	SC	50	OJ309682	5/8 x 4	SC	25
OJ309620	1/2 x 4	SC	25	OJ309705	3/4 x 3	SC	25
OJ309644	5/8 x 2	SC	50	OJ309712	3/4 x 3.1/2	SC	20

Hexagon Set Screws BS1083 Grade R

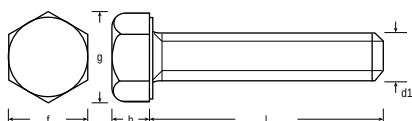

d1		1/4"	5/16"	3/8"	1/2"	5/8"	3/4"
		BSW	BSW	BSW	BSW	BSW	BSW
f	max.	0.445	0.525	0.600	0.820	1.010	1.200
g	max.	0.510	0.610	0.690	0.950	1.170	1.390
h	max.	0.176	0.218	0.260	0.343	0.417	0.500

Product Codes Begin **&WHS** Product Group 3

OJ309798	1/4 x 1/2	SC	200	OJ310077	1/2 x 1.1/4	SC	75
OJ309811	1/4 x 3/4	SC	200	OJ310084	1/2 x 1.1/2	SC	50
OJ309828	1/4 x 1	SC	200	OJ310091	1/2 x 1.3/4	SC	50
OJ309835	1/4 x 1.1/4	SC	200	OJ310107	1/2 x 2	SC	50
OJ309842	1/4 x 1.1/2	SC	200	OJ310121	1/2 x 2.1/2	SC	50
OJ309859	1/4 x 2	SC	200	OJ310138	1/2 x 3	SC	50
OJ309873	1/4 x 3	SC	100	OJ310176	5/8 x 1.1/4	SC	50
OJ309903	5/16 x 5/8	SC	200	OJ310183	5/8 x 1.1/2	SC	50
OJ309910	5/16 x 3/4	SC	200	OJ310190	5/8 x 1.3/4	SC	50
OJ309927	5/16 x 1	SC	200	OJ310206	5/8 x 2	SC	50
OJ309934	5/16 x 1.1/4	SC	200	OJ310220	5/8 x 2.1/2	SC	25
OJ309941	5/16 x 1.1/2	SC	200	OJ310237	5/8 x 3	SC	25
OJ309958	5/16 x 2	SC	100	OJ310244	5/8 x 3.1/2	SC	25
OJ309989	3/8 x 3/4	SC	100	OJ310251	5/8 x 4	SC	25
OJ309996	3/8 x 1	SC	100	OJ310268	3/4 x 1.1/2	SC	25
OJ310008	3/8 x 1.1/4	SC	100	OJ310275	3/4 x 2	SC	25
OJ310015	3/8 x 1.1/2	SC	100	OJ310299	3/4 x 2.1/2	SC	25
OJ310022	3/8 x 2	SC	100	OJ310305	3/4 x 3	SC	25
OJ310046	3/8 x 3	SC	100	OJ310312	3/4 x 4	SC	20
OJ310060	1/2 x 1	SC	100				

CE Approved BS EN 15048 Assembled HT Set, Nut & Washer



DIN 933 Grade 8.8 DIN 934 Class 8 & DIN 125A 100HV

Product Codes Begin **HTSETCE** Product Group 2

Article No.	Size	Finish	Box Qty.						
OJ351353	M12 × 30	CE	BZP	300	OJ395036	M12 × 45	CE	BZP	200
OJ395012	M12 × 35	CE	BZP	200	OJ395043	M12 × 50	CE	BZP	200
OJ395029	M12 × 40	CE	BZP	280					

ISO 4017 Grade 8.8 ISO 4032 Class 8 & ISO 7091 100HV

OJ257945	M16 × 30	CE	BZP	100	OJ258096	M20 × 60	CE	BZP	50
OJ257952	M16 × 35	CE	BZP	100	OJ258102	M20 × 65	CE	BZP	50
OJ257969	M16 × 40	CE	BZP	100	OJ258119	M20 × 70	CE	BZP	50
OJ257976	M16 × 45	CE	BZP	100	OJ258126	M20 × 75	CE	BZP	50
OJ257983	M16 × 50	CE	BZP	100	OJ258133	M20 × 80	CE	BZP	50
OJ257990	M16 × 55	CE	BZP	100	OJ258140	M20 × 90	CE	BZP	50
OJ258003	M16 × 60	CE	BZP	100	OJ258157	M20 × 100	CE	BZP	50
OJ258010	M16 × 65	CE	BZP	100	OJ258164	M24 × 60	CE	BZP	50
OJ258027	M16 × 70	CE	BZP	100	OJ258171	M24 × 65	CE	BZP	50
OJ258034	M16 × 80	CE	BZP	100	OJ258188	M24 × 70	CE	BZP	50
OJ258041	M16 × 100	CE	BZP	50	OJ259222	M24 × 75	CE	BZP	50
OJ258058	M20 × 40	CE	BZP	50	OJ259239	M24 × 80	CE	BZP	40
OJ258065	M20 × 45	CE	BZP	50	OJ259246	M24 × 90	CE	BZP	40
OJ258072	M20 × 50	CE	BZP	50	OJ259253	M24 × 100	CE	BZP	40
OJ258089	M20 × 55	CE	BZP	50					

ISO 4017 Grade 8.8 ISO 4032 Class 10 & ISO 7091 100HV

OJ337814	M12 × 30	CE	HDG	300	OJ252155	M20 × 50	CE	HDG	50
OJ284910	M12 × 35	CE	HDG	280	OJ252162	M20 × 55	CE	HDG	50
OJ312118	M12 × 40	CE	HDG	280	OJ252179	M20 × 60	CE	HDG	50
OJ337821	M12 × 45	CE	HDG	200	OJ252186	M20 × 65	CE	HDG	50
OJ337845	M12 × 50	CE	HDG	200	OJ252193	M20 × 70	CE	HDG	50
OJ312125	M12 × 60	CE	HDG	200	OJ252452	M20 × 75	CE	HDG	50
OJ251998	M16 × 30	CE	HDG	100	OJ253978	M20 × 80	CE	HDG	50
OJ252001	M16 × 35	CE	HDG	100	OJ255217	M20 × 90	CE	HDG	50
OJ252018	M16 × 40	CE	HDG	100	OJ255231	M20 × 100	CE	HDG	50
OJ252025	M16 × 45	CE	HDG	100	OJ255255	M24 × 60	CE	HDG	50
OJ252049	M16 × 50	CE	HDG	100	OJ255279	M24 × 65	CE	HDG	50
OJ252056	M16 × 55	CE	HDG	100	OJ255293	M24 × 70	CE	HDG	50
OJ252063	M16 × 60	CE	HDG	100	OJ255316	M24 × 80	CE	HDG	40
OJ252070	M16 × 65	CE	HDG	100	OJ256474	M24 × 90	CE	HDG	40
OJ252087	M16 × 70	CE	HDG	100	OJ256566	M24 × 100	CE	HDG	40
OJ252094	M16 × 75	CE	HDG	100	OJ269511	M30 × 90	CE	HDG	20
OJ252100	M16 × 80	CE	HDG	100	OJ269528	M30 × 100	CE	HDG	20
OJ252117	M16 × 90	CE	HDG	100	OJ269535	M30 × 110	CE	HDG	20
OJ252124	M16 × 100	CE	HDG	50	OJ269559	M30 × 130	CE	HDG	20
OJ252131	M20 × 40	CE	HDG	50	OJ269566	M30 × 140	CE	HDG	20
OJ252148	M20 × 45	CE	HDG	50					



Square Square Holding Down Bolts & Nuts

BS7419 Grade 4.6



Product Codes Begin **SQSQ** Product Group **1**

Article No.	Size	Finish	Box Qty.				
OJ189086	M20 × 300	SC	25	OJ189109	M20 × 400	SC	20
OJ189093	M20 × 375	SC	20	OJ189116	M20 × 450	SC	20

BS7419 Grade 8.8

OJ189192	M16 × 300	BZP	40	OJ189277	M24 × 300	BZP	15
OJ189208	M16 × 375	BZP	30	OJ189284	M24 × 375	BZP	15
OJ189215	M16 × 450	BZP	30	OJ676333	M24 × 400	BZP	15
OJ189222	M20 × 300	BZP	25	OJ189291	M24 × 450	BZP	10
OJ189239	M20 × 375	BZP	20	OJ189307	M24 × 600	BZP	10
OJ189246	M20 × 400	BZP	20	OJ189314	M30 × 450	BZP	5
OJ189253	M20 × 450	BZP	20	OJ189321	M30 × 600	BZP	5
OJ189260	M20 × 600	BZP	15				

Square Plate Washers

Square Plate, Square Hole



Product Codes Begin **VP 100** Product Group **19**

Article No.	Thickness mm Plate Size ID	Finish	Box Qty.
OJ189352	M16 × 100 × 100 × 10	SC	30
OJ366272	M20 × 100 × 100 × 6	SC	50
OJ189345	M20 × 100 × 100 × 10	SC	30
OJ366289	M24 × 100 × 100 × 6	SC	50
OJ189369	M24 × 100 × 100 × 10	SC	30
OJ189376	M30 × 100 × 100 × 10	SC	30

Waxed Cones



Product Codes Begin **SQSQCONE** Product Group **2001**

Article No.	Size	Box Qty.
OJ678160	229mm to Suit 300mm Bolt	1
OJ678177	305mm to Suit 375-400mm Bolt	1
OJ678184	380mm to Suit 450mm Bolt	1
OJ678191	535mm to Suit 600mm Bolt	1

BZP Cup Square Hex Bolts & Nuts

DIN 603/555 ISO 898-1 Grade 4.8

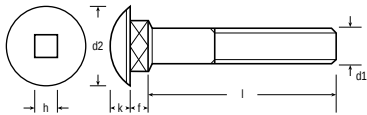

	d1	M6	M8	M10	M12	M16
d2 max.		16.55	20.65	24.65	30.65	38.8
k max.		3.88	4.88	5.38	6.95	8.95
f max.		4.6	5.6	6.6	8.75	12.9
h min.		6.48	8.58	10.58	12.7	16.7

Product Codes Begin **CSXD** Product Group 16

Article No.	Size	Box Qty.	Article No.	Size	Box Qty.	Article No.	Size	Box Qty.
OJ472010	M6 × 20	200	OJ472386	M8 × 130	50	OJ515724	M12 × 35	50
OJ472027	M6 × 25	200	OJ515656	M8 × 140	25	OJ472768	M12 × 40	50
OJ472034	M6 × 30	200	OJ472409	M8 × 150	25	OJ515731	M12 × 45	25
OJ472041	M6 × 35	200	OJ003412	M8 × 160	25	OJ472782	M12 × 50	25
OJ472058	M6 × 40	200	OJ511498	M8 × 180	25	OJ515748	M12 × 60	25
OJ472065	M6 × 45	200	OJ003429	M8 × 200	25	OJ472805	M12 × 65	25
OJ472072	M6 × 50	100	OJ515663	M10 × 20	100	OJ515755	M12 × 70	25
OJ472089	M6 × 55	100	OJ472454	M10 × 25	100	OJ472829	M12 × 75	25
OJ003405	M6 × 60	100	OJ472461	M10 × 30	100	OJ515762	M12 × 80	25
OJ472102	M6 × 65	100	OJ515670	M10 × 35	50	OJ472843	M12 × 90	25
OJ472119	M6 × 70	100	OJ472485	M10 × 40	50	OJ472850	M12 × 100	25
OJ472126	M6 × 75	100	OJ472492	M10 × 45	50	OJ472867	M12 × 110	25
OJ472133	M6 × 80	100	OJ472508	M10 × 50	50	OJ003450	M12 × 120	10
OJ472140	M6 × 90	100	OJ472515	M10 × 55	50	OJ472881	M12 × 130	10
OJ472157	M6 × 100	100	OJ515687	M10 × 60	50	OJ472898	M12 × 140	10
OJ472164	M6 × 110	100	OJ472539	M10 × 65	50	OJ472904	M12 × 150	10
OJ515595	M6 × 120	100	OJ472546	M10 × 70	50	OJ472911	M12 × 160	10
OJ472188	M6 × 130	50	OJ472553	M10 × 75	50	OJ472928	M12 × 180	10
OJ515601	M6 × 140	50	OJ003436	M10 × 80	50	OJ472935	M12 × 200	10
OJ472201	M6 × 150	50	OJ472577	M10 × 90	25	OJ003467	M12 × 220	10
OJ515618	M8 × 20	200	OJ472584	M10 × 100	25	OJ472959	M12 × 230	10
OJ472225	M8 × 25	100	OJ472591	M10 × 110	25	OJ472966	M12 × 240	10
OJ472232	M8 × 30	100	OJ003443	M10 × 120	25	OJ472973	M12 × 260	10
OJ472249	M8 × 35	100	OJ472614	M10 × 130	25	OJ472980	M12 × 280	10
OJ472256	M8 × 40	100	OJ472621	M10 × 140	25	OJ472997	M12 × 300	10
OJ472263	M8 × 45	100	OJ472638	M10 × 150	25	OJ003511	M16 × 50	10
OJ472270	M8 × 50	100	OJ472645	M10 × 160	25	OJ003535	M16 × 60	10
OJ472287	M8 × 55	100	OJ472652	M10 × 180	15	OJ003542	M16 × 65	10
OJ515625	M8 × 60	100	OJ472669	M10 × 200	15	OJ003559	M16 × 70	10
OJ472300	M8 × 65	50	OJ515694	M10 × 220	15	OJ003566	M16 × 80	10
OJ472317	M8 × 70	50	OJ472683	M10 × 230	15	OJ003573	M16 × 90	10
OJ472324	M8 × 75	50	OJ472690	M10 × 240	10	OJ003597	M16 × 100	10
OJ515632	M8 × 80	50	OJ472706	M10 × 260	15	OJ003603	M16 × 110	10
OJ472348	M8 × 90	50	OJ472713	M10 × 280	10	OJ003610	M16 × 120	10
OJ472355	M8 × 100	50	OJ472720	M10 × 300	15	OJ121215	M16 × 130	10
OJ472362	M8 × 110	50	OJ515700	M12 × 25	50			
OJ515649	M8 × 120	50	OJ515717	M12 × 30	50			



HDG Cup Square Bolts Only

DIN 603

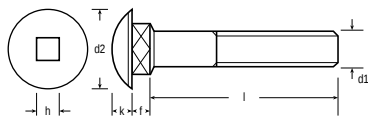

	d1	M8	M10	M12
d2 max.		20.65	24.65	30.65
k max.		4.88	5.38	6.95
f max.		5.6	6.6	8.75
h min.		8.58	10.58	12.7

Product Codes Begin **CSB** Product Group **26**

Article No.	Size	Box Qty.	Article No.	Size	Box Qty.
OJ279596	M8 × 25	100	OJ279732	M10 × 50	50
OJ279602	M8 × 30	100	OJ279749	M10 × 60	50
OJ279619	M8 × 40	100	OJ279756	M10 × 70	50
OJ279626	M8 × 50	100	OJ279763	M10 × 75	50
OJ279633	M8 × 55	100	OJ279770	M10 × 80	50
OJ279640	M8 × 60	100	OJ279787	M10 × 90	50
OJ279657	M8 × 70	100	OJ279794	M10 × 100	50
OJ279664	M8 × 75	100	OJ279800	M12 × 30	50
OJ279671	M8 × 80	100	OJ279817	M12 × 40	50
OJ279688	M8 × 90	100	OJ279824	M12 × 75	50
OJ279695	M8 × 100	100	OJ279831	M12 × 90	50
OJ279701	M10 × 25	100	OJ279848	M12 × 100	50
OJ279718	M10 × 30	50	OJ279855	M12 × 110	50
OJ279725	M10 × 40	50			



HDG Shear Nuts

Product Codes Begin **CSSN** Product Group **26**

Article No.	Size	Box Qty.
OJ279862	M8 × 17mm A/F	100
OJ279879	M10 × 19mm A/F	100
OJ279886	M12 × 22mm A/F	100



HDG Saddle Bolts

Product Codes Begin **CSSB** Product Group **26**

OJ279893	M8 × 40	100
----------	---------	-----



HDG Tee Head Bolts

Product Codes Begin **CSTB** Product Group **26**

OJ279909	M8 × 25	100
----------	---------	-----

Studding

Mild Steel DIN 975 ISO 898-1 Metric Thread Grade 4.6

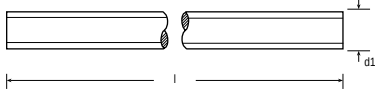

1 Metre Lengths

Product Codes Begin **IISM** Product Group **12**

Article No.	Size	Finish									
OJ166018	M3	BZP	OJ225326	M16	BZP	OJ347936	M8	SC	OJ348223	M24	SC
OJ347844	M4	BZP	OJ225333	M20	BZP	OJ347981	M10	SC	OJ348278	M27	SC
OJ347868	M5	BZP	OJ348230	M24	BZP	OJ348049	M12	SC	OJ348285	M30	SC
OJ347899	M6	BZP	OJ348292	M30	BZP	OJ348094	M14	SC	OJ348322	M36	SC
OJ347943	M8	BZP	OJ347820	M3	SC	OJ348124	M16	SC	OJ348346	M39	SC
OJ347998	M10	BZP	OJ347837	M4	SC	OJ348162	M18	SC	OJ348353	M42	SC
OJ348056	M12	BZP	OJ347851	M5	SC	OJ348179	M20	SC			
OJ348100	M14	BZP	OJ347882	M6	SC	OJ348216	M22	SC			

2 Metre Lengths

OJ347905	M6	BZP	OJ348001	M10	BZP	OJ348131	M16	BZP	OJ348247	M24	BZP
OJ347950	M8	BZP	OJ348063	M12	BZP	OJ348186	M20	BZP	OJ348308	M30	BZP

3 Metre Lengths

OJ347875	M5	BZP	OJ348155	M16	BZP	OJ347912	M6	SC	OJ348148	M16	SC
OJ347929	M6	BZP	OJ348209	M20	BZP	OJ347967	M8	SC	OJ348193	M20	SC
OJ347974	M8	BZP	OJ348261	M24	BZP	OJ348018	M10	SC	OJ348254	M24	SC
OJ348025	M10	BZP	OJ126456	M30	BZP	OJ348070	M12	SC	OJ348315	M30	SC
OJ348087	M12	BZP	OJ126432	M5	SC	OJ348117	M14	SC			

High Tensile ISO 898-1 Metric Thread Grade 8.8

Note: BZP CR3

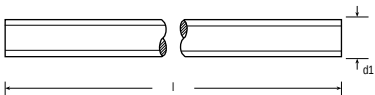

1 Metre Lengths

Product Codes Begin **IISMH** Product Group **12**

OJ393933	M6	BZP	OJ676982	M24	BZP	OJ676975	M20	HDG	OJ348384	M10	SC
OJ393940	M8	BZP	OJ677002	M30	BZP	OJ676999	M24	HDG	OJ348391	M12	SC
OJ372747	M10	BZP	OJ677026	M36	BZP	OJ677019	M30	HDG	OJ348407	M16	SC
OJ676920	M12	BZP	OJ283746	M10	HDG	OJ677033	M36	HDG	OJ348414	M18	SC
OJ676944	M16	BZP	OJ676937	M12	HDG	OJ348360	M6	SC	OJ348421	M20	SC
OJ676968	M20	BZP	OJ676951	M16	HDG	OJ348377	M8	SC	OJ348438	M24	SC

3 Metre Lengths

OJ564470	M10	BZP	OJ422541	M6	BZP	OJ422589	M24	BZP
OJ422534	M12	BZP	OJ422565	M20	BZP			



High Tensile ISO 898-1 Metric Thread **Grade 10**

A higher tensile strength than grade 8.8

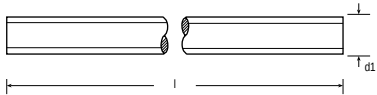

1 Metre Lengths

Product Codes Begin **IISMT** Product Group **12**

Article No.	Size	Finish						
OJ284231	M8	SC	OJ284262	M16	SC	OJ284293	M24	SC
OJ284248	M10	SC	OJ284279	M18	SC	OJ284309	M27	SC
OJ284255	M12	SC	OJ284286	M20	SC	OJ284316	M30	SC

Brass Studding DIN 975 Metric Thread

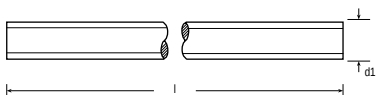

1 Metre Lengths

Product Codes Begin **Q60975** Product Group **3510**

HX289878	M3	HX289908	M6	HX289939	M12
HX289885	M4	HX289915	M8		
HX289892	M5	HX289922	M10		

Mild Steel Whitworth Thread

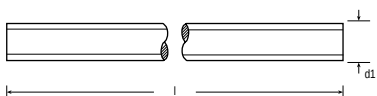

3ft Lengths

Product Codes Begin **IISWH** Product Group **12**

OJ348605	3/8"	BZP	OJ348568	1/4"	SC	OJ348650	5/8"	SC	OJ348759	1.1/4"	SC
OJ348636	1/2"	BZP	OJ348582	5/16"	SC	OJ348681	3/4"	SC	OJ348773	1.1/2"	SC
OJ348667	5/8"	BZP	OJ348599	3/8"	SC	OJ348711	7/8"	SC			
OJ348698	3/4"	BZP	OJ348629	1/2"	SC	OJ348735	1"	SC			

10ft Lengths

OJ348612	3/8"	SC	OJ348674	5/8"	SC
OJ348643	1/2"	SC	OJ348704	3/4"	SC

> Studding

Mild Steel BSF Thread

3ft Lengths

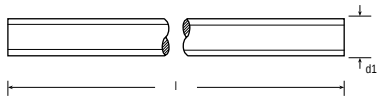

Product Codes Begin **IISBF** Product Group **12**

Article No.	Size	Finish
OJ347783	1/2"	SC
OJ347790	5/8"	SC
OJ347806	3/4"	SC
OJ347813	1"	SC

Mild Steel UNC Thread

3ft Lengths

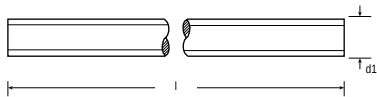

Product Codes Begin **IISNC** Product Group **12**

OJ348445	3/8"	SC
OJ348452	1/2"	SC
OJ348469	5/8"	SC
OJ348476	3/4"	SC
OJ348483	7/8"	SC
OJ348490	1"	SC

Mild Steel UNF Thread

3ft Lengths

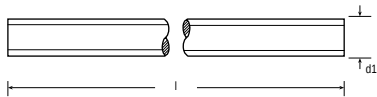

Product Codes Begin **IISNF** Product Group **12**

OJ348506	3/8"	SC
OJ348513	1/2"	SC
OJ348520	5/8"	SC
OJ348537	3/4"	SC
OJ348551	1"	SC

BZP Studding Connectors DIN 6334

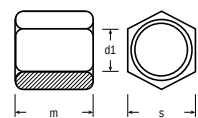

d1	M6	M8	M10	M12	M16	M20	M24
m	18	24	30	36	48	60	72
s	10	13	17	19	24	30	36

Carton

Product Codes Begin **IISXS** Product Group **12**

Article No.	Size	Box Qty.
OJ348797	M6/18	3000
OJ348803	M8/24	1300
OJ348810	M10/30	500
OJ348827	M12/36	400
OJ348834	M16/48	200
OJ348841	M20/60	100
OJ348858	M24/72	80

Small Box

OJ125152	M6/18	100	OJ125183	M12/36	25
OJ125169	M8/24	75	OJ125190	M16/48	20
OJ125176	M10/30	100	OJ125206	M20/60	10



Mild Steel All Thread Zinc Studs

Product Codes Begin **MSAZ** Product Group **45**

Article No.	Size	Box Qty.
OJ041728	M4 x 20	200
OJ041735	M4 x 25	200
OJ041742	M4 x 30	200
OJ041759	M4 x 35	200
OJ041766	M4 x 40	200
OJ041773	M4 x 45	200
OJ041780	M4 x 50	200
OJ041797	M4 x 55	100
OJ041803	M4 x 60	100
OJ041810	M4 x 65	100
OJ041827	M4 x 70	100
OJ041834	M4 x 75	100
OJ041841	M4 x 80	100
OJ041858	M4 x 90	100
OJ041865	M4 x 100	100
OJ041872	M5 x 20	200
OJ041889	M5 x 25	200
OJ041896	M5 x 30	200
OJ041902	M5 x 35	200
OJ041919	M5 x 40	200
OJ041926	M5 x 45	200
OJ041933	M5 x 50	200
OJ041940	M5 x 55	100
OJ041957	M5 x 60	100
OJ041964	M5 x 70	100
OJ041971	M5 x 75	100
OJ041988	M5 x 80	100
OJ041995	M5 x 90	100
OJ042008	M5 x 100	100
OJ042015	M5 x 110	100
OJ042022	M5 x 120	50
OJ042039	M6 x 20	200
OJ042046	M6 x 25	200
OJ042053	M6 x 30	200

OJ042060	M6 x 35	200
OJ042077	M6 x 40	200
OJ042084	M6 x 45	100
OJ042091	M6 x 50	100
OJ042107	M6 x 55	100
OJ042114	M6 x 60	100
OJ042121	M6 x 70	100
OJ042138	M6 x 75	100
OJ042145	M6 x 80	50
OJ042152	M6 x 90	50
OJ042169	M6 x 100	50
OJ042176	M6 x 110	50
OJ042183	M6 x 120	50
OJ042190	M6 x 130	50
OJ042206	M6 x 140	50
OJ042213	M6 x 150	50
OJ042220	M6 x 175	50
OJ042237	M8 x 25	50
OJ042244	M8 x 30	50
OJ042251	M8 x 40	50
OJ042268	M8 x 50	50
OJ042275	M8 x 60	50
OJ042282	M8 x 70	50
OJ042299	M8 x 75	50
OJ042305	M8 x 80	25
OJ042312	M8 x 90	25
OJ042329	M8 x 100	25
OJ042336	M8 x 110	25
OJ042343	M8 x 120	25
OJ042350	M8 x 130	25
OJ042367	M8 x 140	25
OJ042374	M8 x 150	25
OJ042381	M8 x 160	25
OJ042398	M8 x 170	25
OJ042404	M8 x 180	25

OJ042411	M8 x 200	25
OJ042428	M10 x 25	50
OJ042435	M10 x 30	50
OJ042442	M10 x 40	50
OJ042459	M10 x 50	50
OJ042466	M10 x 60	25
OJ042473	M10 x 70	25
OJ042480	M10 x 75	25
OJ042497	M10 x 80	25
OJ042503	M10 x 90	25
OJ042510	M10 x 100	20
OJ042527	M10 x 110	20
OJ042534	M10 x 120	20
OJ042541	M10 x 125	20
OJ042558	M10 x 140	20
OJ042565	M10 x 150	20
OJ042572	M10 x 170	10
OJ042589	M10 x 200	10
OJ042596	M12 x 25	40
OJ042602	M12 x 35	40
OJ042619	M12 x 40	40
OJ042626	M12 x 50	20
OJ042633	M12 x 60	20
OJ042640	M12 x 70	20
OJ042657	M12 x 75	20
OJ042664	M12 x 80	10
OJ042671	M12 x 90	10
OJ042688	M12 x 100	10
OJ042695	M12 x 110	10
OJ042701	M12 x 120	10
OJ042718	M12 x 125	10
OJ042725	M12 x 130	10
OJ042732	M12 x 140	10
OJ042749	M12 x 150	10
OJ042756	M12 x 175	10

Channel Accessories

Plain Cantilever Arms HDG



Product Codes Begin **CHPCA** Product Group **14**

Article No.	Size	Box Qty.			
OJ032115	150mm	8	OJ032146	600mm	8
OJ032122	300mm	8	OJ032153	750mm	8
OJ032139	450mm	8			

Flat Plate Hole Brackets HDG

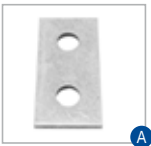

Product Codes Begin **CHF** Product Group **14**



Article No.	Size	Box Qty.			
OJ032160	40 x 84	50	OJ032191	86 x 86	25
OJ032177	40 x 126	50	OJ032207	89 x 138	25
OJ032184	40 x 168	50			



Right Angle Hole Brackets HDG



Product Codes Begin **CHRA B** Product Group **14**



OJ032214	48 x 50	8	OJ032245	41 x 102	8
OJ032221	50 x 96	8	OJ032252	55 x 132	8
OJ032238	57 x 90	8	OJ032269	86 x 102	8



Angle Brackets



Product Codes Begin **CHOAB/CHAAB** Product Group **14**



Article No.	Size	Box Qty.	
OJ032276	Obtuse 58 x 75mm	25	A
OJ032283	Acute 72 x 108mm	25	B



Gusset Base Plate HDG

Product Codes Begin **CHGBP** Product Group **14**

Article No.	Size	Box Qty.
OJ032290	41mm	12



Window Beam Clamps HDG

Product Codes Begin **CHWBC** Product Group **14**

OJ032306	41mm	25
OJ032313	21mm	25



Base Plates HDG

Product Codes Begin **CHBP** Product Group **14**

OJ032320	40mm	25
----------	------	----



Joint Plates HDG

Product Codes Begin **CHJP** Product Group **14**

OJ032337	Internal 41 x 41mm	25	A
OJ032344	External 41 x 41mm	10	B



Purlin Clips HDG

Product Codes Begin **CHPC** Product Group **14**

OJ032351	Z10	100
----------	-----	-----



HT Hex Sets - Cone Point

Product Codes Begin **CHCPS** Product Group **14**

Article No.	Size	Box Qty.
OJ032498	M10 x 40	100



PVC End Caps

Product Codes Begin **CHEC** Product Group **14**

Article No.	Size	Colour	Box Qty.
OJ032504	41 x 41	Black	100
OJ032511	41 x 21	Black	100
OJ032528	41 x 41	White	100
OJ032535	41 x 21	White	100



Wedge Nuts

Product Codes Begin **CHWN** Product Group **14**

Article No.	Size	Box Qty.
OJ032542	M6	100
OJ032559	M8	100
OJ032566	M10	100
OJ032573	M12	100



BZP Channel Nuts

Product Codes Begin **ZZJ100** Product Group **14**



Article No.	Size	Type	Box Qty.
J10047	M6	Plain	100
J10048	M6	Short	100
J10049	M6	Long	100
J10050	M8	Plain	100
J10051	M8	Short	100
J10052	M8	Long	100
J10053	M10	Plain	100
J10054	M10	Short	100
J10055	M10	Long	100
J10056	M12	Plain	100
J10057	M12	Short	100
J10058	M12	Long	100

NEW & EXTENDED RANGES OF A2 AND A4 STAINLESS STEEL NOW AVAILABLE



- Hexagon Bolts / Sets • Self-Tappers • Machine Screws (inc: Torx)
- Security Screws • Studding • Woodscrews / Chipboard Screws
- Socket Screws (inc: Torx, Flange, ISO spec & Fully Threaded)
- Nuts (inc: Fine Pitch, Round Coupling Nuts & Knurled Thumb Nuts)
- Washers (inc: Curved Spring, Turned/Stamped Cup, Ext Tab, Cheese, 1&2 Tab)

Ask your local sales office for more information

or see pages 161-194 for our core range

Nuts

Metric Hexagon Full Nuts DIN 934

Note: HDG are Tapped and O/Size. BZP CR3.

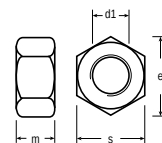

d1	M2	M2.5	M3	M3.5	M4	M5	M6	M7	M8	M10	M12	M14	M16	M18	M20
m max.	1.48	1.88	2.4	2.68	3.2	4.0	5.0	5.5	6.5	8.0	10.0	11.0	13.0	14.65	16.0
e					7.66	8.79	11.05	12.12	14.38	18.90	21.10	24.49	26.79		32.95
s	4.00	5.00	5.5	6.00	7.0	8.0	10.0	11.0	13.0	17.0	19.0	22.0	24.0	27.00	30.0

Carton

Product Codes Begin **NFFMC** Product Group 4

Article No.	Size	Finish	Grade	Box Qty.											
OJ676883	M4	BZP	8	32000	OJ359083	M8	HDG	6	5000	OJ677071	M36	HDG	10	50	
OJ359182	M5	BZP	8	22000	OJ359090	M10	HDG	6	2300	OJ358826	M6	SC	8	11000	
OJ359199	M6	BZP	8	11000	OJ359106	M12	HDG	6	1500	OJ358833	M8	SC	8	5000	
OJ359205	M8	BZP	8	5000	OJ677057	M12	HDG	10	1500	OJ358840	M10	SC	8	2300	
OJ359212	M10	BZP	8	2300	OJ359113	M16	HDG	6	800	OJ358857	M12	SC	8	1500	
OJ359229	M12	BZP	8	1500	OJ170947	M16	HDG	10	800	OJ358864	M14	SC	8	1000	
OJ359236	M14	BZP	8	1000	OJ359120	M20	HDG	6	400	OJ358871	M16	SC	8	850	
OJ359243	M16	BZP	8	800	OJ170954	M20	HDG	10	400	OJ358895	M20	SC	8	400	
OJ359267	M20	BZP	8	400	OJ676890	M24	HDG	6	240	OJ358918	M24	SC	8	200	
OJ359281	M24	BZP	8	220	OJ170978	M24	HDG	10	240	OJ358932	M30	SC	6	120	
OJ359298	M30	BZP	6	120	OJ676906	M30	HDG	6	100						
OJ676913	M36	BZP	6	50	OJ677064	M30	HDG	10	100						

Small Box

Product Codes Begin **NFFMS** Product Group 4

OJ220727	M2	BZP	8	2000	OJ006178	M10	BZP	8	200	OJ284101	M20	BZP	10	100
OJ220666	M2.5	BZP	8	1000	OJ284057	M10	BZP	10	500	OJ220710	M22	BZP	8	25
OJ220673	M3	BZP	8	1000	OJ006185	M12	BZP	8	100	OJ359663	M24	BZP	8	25
OJ220680	M3.5	BZP	8	1000	OJ284064	M12	BZP	10	250	OJ284132	M24	BZP	10	100
OJ359649	M4	BZP	8	2000	OJ359656	M14	BZP	8	100	OJ443522	M27	BZP	8	25
OJ509501	M5	BZP	8	1000	OJ144566	M16	BZP	8	100	OJ284156	M27	BZP	10	50
OJ242309	M6	BZP	8	200	OJ284088	M16	BZP	10	200	OJ359670	M30	BZP	6	10
OJ220697	M7	BZP	8	500	OJ220703	M18	BZP	8	50	OJ284187	M30	BZP	10	25
OJ242316	M8	BZP	8	200	OJ144573	M20	BZP	8	50					



M22	M24	M27	M30	M33	M36	M42	M48
17.45	19.0	21.35	24.0	26.0	29.0	33.20	37.20
	39.55		50.85	55.37	60.79		
32.00	36.0	41.00	46.0	50.0	55.0	65.00	75.00

Product Codes Begin **NFFMS** Product Group 4

Article No.	Size	Finish	Grade	Box Qty.
OJ279916	M8	HDG	6	200
OJ279923	M10	HDG	6	200
OJ279930	M12	HDG	6	100
OJ547527	M16	HDG	6	100
OJ547534	M20	HDG	6	50
OJ547541	M24	HDG	6	25
OJ263168	M10	HDG	10	200
OJ272757	M12	HDG	10	100
OJ272764	M16	HDG	10	100
OJ272771	M20	HDG	10	50
OJ272788	M24	HDG	10	25
OJ284163	M27	HDG	10	50
OJ284194	M30	HDG	10	25
OJ284972	M33	HDG	6	20
OJ222639	M6	ZYP	8	200
OJ222646	M8	ZYP	8	200
OJ222653	M10	ZYP	8	200
OJ222677	M12	ZYP	8	100
OJ222684	M16	ZYP	8	100
OJ222691	M20	ZYP	8	50
OJ222707	M24	ZYP	8	25
OJ220659	M4	SC	8	1000

OJ030173	M5	SC	8	1000
OJ030180	M6	SC	8	200
OJ284033	M6	SC	10	1000
OJ284583	M6	SC	12	500
OJ030197	M8	SC	8	200
OJ284040	M8	SC	10	500
OJ284590	M8	SC	12	500
OJ030203	M10	SC	8	200
OJ222943	M10	SC	10	200
OJ284606	M10	SC	12	500
OJ030210	M12	SC	8	100
OJ222950	M12	SC	10	100
OJ284613	M12	SC	12	500
OJ359397	M14	SC	8	100
OJ284071	M14	SC	10	200
OJ359403	M16	SC	8	100
OJ222967	M16	SC	10	100
OJ284620	M16	SC	12	200
OJ222233	M18	SC	8	50
OJ284095	M18	SC	10	100
OJ284637	M18	SC	12	100
OJ359427	M20	SC	8	50

OJ222974	M20	SC	10	50
OJ284644	M20	SC	12	100
OJ222363	M22	SC	8	50
OJ284118	M22	SC	10	100
OJ359441	M24	SC	8	25
OJ284125	M24	SC	10	100
OJ284668	M24	SC	12	50
OJ222240	M27	SC	6	25
OJ284149	M27	SC	10	50
OJ284675	M27	SC	12	25
OJ359458	M30	SC	6	10
OJ284170	M30	SC	10	25
OJ284682	M30	SC	12	25
OJ222387	M33	SC	6	10
OJ284200	M33	SC	10	10
OJ359465	M36	SC	6	10
OJ284217	M36	SC	10	10
OJ284224	M39	SC	10	10
OJ222615	M42	SC	6	5
OJ222257	M48	SC	6	5

> Nuts

Brass Metric Hexagon Full Nuts DIN 934

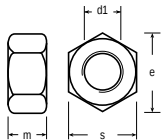

d1	M2	M2.5	M3	M3.5	M4	M5	M6	M8	M10	M12	M16	M20
m	1.6	2.0	2.4	2.8	3.2	4.0	5.0	6.5	8.0	10.0	13.0	16.0
e	4.32	5.45	6.01	6.58	7.66	8.79	11.05	14.38	18.90	21.10	26.75	32.95
s	4.0	5.0	5.5	6.0	7.0	8.0	10.0	13.0	17.0	19.0	24.0	30.0

Product Codes Begin **Q60934** Product Group **3506**

Article No.	Size	Box Qty.	Article No.	Size	Box Qty.	Article No.	Size	Box Qty.
HX289199	M2	5000	HX289236	M4	200	HX289274	M10	200
HX289205	M2.5	5000	HX289243	M5	100	HX289281	M12	100
HX289212	M3	200	HX289250	M6	500	HX289298	M16	100
HX289229	M3.5	2000	HX289267	M8	200	HX289304	M20	50

Metric Hexagon Full Nuts Fine Pitch

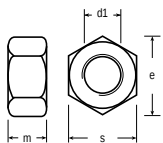

d1	M10	M12	M16	M20
m max.	8.0	10.0	13.0	16.0
e min.	18.90	21.10	26.79	32.95
s	17.0	19.0	24.0	30.0

Product Codes Begin **NFFMSF** Product Group **4**

Article No.	Size	Finish	Grade/Spec	Box Qty.	Article No.	Size	Finish	Grade/Spec	Box Qty.
OJ222882	M10×1.00	SC	Grade 8	200	OJ222912	M12×1.50	SC	Grade 8	100
OJ222899	M10×1.25	SC	Grade 8	200	OJ222929	M16×1.50	SC	Grade 8	100
OJ222905	M12×1.25	SC	Grade 8	100	OJ222936	M20×1.50	SC	Grade 8	50

UNC Hexagon Full Nuts

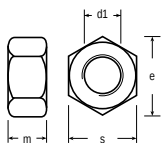

d1	10-24	1/4"	5/16"	3/8"	7/16"	1/2"	5/8"	3/4"	7/8"	1
m max.	0.130	0.226	0.273	0.337	0.385	0.448	0.559	0.665	0.776	0.887
e max.	0.433	0.505	0.577	0.650	0.794	0.866	1.083	1.299	1.5165	1.732
s max.	0.312	0.438	0.500	0.562	0.688	0.750	0.938	1.125	1.312	1.500

Product Codes Begin **NFFCS** Product Group **4**

Article No.	Size	Finish	Grade/Spec	Box Qty.	Article No.	Size	Finish	Grade/Spec	Box Qty.
OJ358338	1/4-20UNC	BZP	Grade 1 / BS1768	200	OJ358253	3/8-16UNC	SC	Grade 1 / BS1768	200
OJ358345	5/16-18UNC	BZP	Grade 1 / BS1768	200	OJ358277	1/2-13UNC	SC	Grade 1 / BS1768	100
OJ358352	3/8-16UNC	BZP	Grade 1 / BS1768	200	OJ358291	5/8-11UNC	SC	Grade 1 / BS1768	100
OJ358369	7/16-14UNC	BZP	Grade 1 / BS1768	100	OJ358307	3/4-10UNC	SC	Grade 1 / BS1768	50
OJ358376	1/2-13UNC	BZP	Grade 1 / BS1768	100	OJ358314	7/8-9UNC	SC	Grade 2 / ANSI B18.2.2	10
OJ358383	5/8-11UNC	BZP	Grade 1 / BS1768	100	OJ358321	1 UNC	SC	Grade 2 / 8TPI ANSI B18.2.2	10
OJ358390	3/4-10UNC	BZP	Grade 1 / BS1768	50					
OJ358239	1/4-20UNC	SC	Grade 1 / BS1768	200					
OJ358246	5/16-18UNC	SC	Grade 1 / BS1768	200					



UNF Hexagon Full Nuts

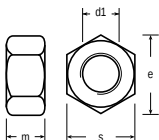

d1	10-32	1/4"	5/16"	3/8"	7/16"	1/2"	9/16"	5/8"	3/4"	7/8"	1
m max.	0.130	0.226	0.273	0.337	0.385	0.448	0.469	0.559	0.665	0.776	0.887
e max.	0.433	0.505	0.577	0.650	0.794	0.866	1.101	1.083	1.299	1.516	1.732
s max.		0.438	0.500	0.562	0.688	0.750	0.875	0.938	1.125	1.312	1.500

Product Codes Begin **NFFFS** Product Group 4

Article No.	Size	Finish	Grade/Spec	Box Qty.					
OJ358703	1/4 - 28UNF	BZP	Grade 1 / BS1768	200	OJ358628	5/16 - 24UNF	SC	Grade 1 / BS1768	200
OJ358710	5/16 - 24UNF	BZP	Grade 1 / BS1768	200	OJ358635	3/8 - 24UNF	SC	Grade 1 / BS1768	200
OJ358727	3/8 - 24UNF	BZP	Grade 1 / BS1768	200	OJ358659	1/2 - 20UNF	SC	Grade 1 / BS1768	100
OJ358734	7/16 - 20UNF	BZP	Grade 1 / BS1768	100	OJ220611	9/16 - 18UNF	SC	Grade 1 / BS1768	100
OJ358741	1/2 - 20UNF	BZP	Grade 1 / BS1768	100	OJ358666	5/8 - 18UNF	SC	Grade 1 / BS1768	100
OJ358758	5/8 - 18UNF	BZP	Grade 1 / BS1768	100	OJ358673	3/4 - 16UNF	SC	Grade 1 / BS1768	50
OJ358765	3/4 - 16UNF	BZP	Grade 1 / BS1768	50	OJ358680	7/8 - 14UNF	SC	Grade 2 / ANSI B18.2.2	10
OJ220598	10 - 32UNF.312AF	SC	BS1981	1000	OJ358697	1 - UNF12TPI	SC	Grade 2 / ANSI B18.2.2	10
OJ220604	10 - 32UNF.375AF	SC	BS1981	1000					
OJ358611	1/4 - 28UNF	SC	Grade 1 / BS1768	200					

BSW Hexagon Full Nuts

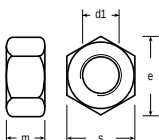

d1	3/16"	1/4"	5/16"	3/8"	1/2"	5/8"	3/4"	7/8"	1	1.1/8"	1.1/4"	1.1/2"	1.3/4"	2"
m	0.162	0.200	0.250	0.312	0.437	0.562	0.687	.750	0.875	1.000	1.125	1.375	1.625	1.750
e	0.374	0.510	0.610	0.690	0.950	1.170	1.390	1.500	1.710	1.930	2.150	2.560	2.98	3.19
s	0.324	0.445	0.525	0.600	0.820	1.010	1.200	1.300	1.480	1.670	1.860	2.220	2.580	2.760

Product Codes Begin **NFFWS** Product Group 4

Article No.	Size	Finish	Grade/Spec	Box Qty.					
OJ220833	3/16 BSW	BZP	BS1083	1000	OJ359915	1/2 BSW	SC	BS1083	100
OJ220840	1/4 BSW	BZP	BS1083	1000	OJ359922	5/8 BSW	SC	BS1083	100
OJ220857	5/16 BSW	BZP	BS1083	1000	OJ359939	3/4 BSW	SC	BS1083	50
OJ220864	3/8 BSW	BZP	BS1083	500	OJ220765	7/8 BSW	SC	BS916	10
OJ222301	1/2 BSW	BZP	BS1083	100	OJ220772	1 BSW	SC	BS916	10
OJ222714	5/8 BSW	BZP	BS1083	100	OJ220789	1.1/8 BSW	SC	BS916	5
OJ222721	3/4 BSW	BZP	BS1083	50	OJ220796	1.1/4 BSW	SC	BS916	5
OJ030265	1/4 BSW	SC	BS1083	200	OJ220802	1.1/2 BSW	SC	BS916	5
OJ030272	5/16 BSW	SC	BS1083	200	OJ220819	1.3/4 BSW	SC	BS916	5
OJ359908	3/8 BSW	SC	BS1083	200	OJ220826	2 BSW	SC	BS916	5

> Nuts

BSF Hexagon Full Nuts BS1083

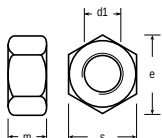

d1	1/4"	5/16"	3/8"	1/2"	5/8"	3/4"
m	0.200	0.250	0.312	0.437	0.562	0.687
e	0.510	0.610	0.690	0.950	1.170	1.390
s	0.445	0.525	0.600	0.820	1.010	1.200

Product Codes Begin **UFFBS** Product Group **4**

Article No.	Size	Finish	Qty.				
OJ220529	1/4 BSF	SC	200	OJ220550	1/2 BSF	SC	100
OJ220536	5/16 BSF	SC	200	OJ220567	5/8 BSF	SC	100
OJ220543	3/8 BSF	SC	200	OJ220574	3/4 BSF	SC	50

BA Hexagon Full Nuts BS57

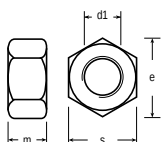

d1	2BA	4BA
m	0.167	0.135
e	0.370	0.290
s	0.324	0.248

Product Codes Begin **UFFAS** Product Group **4**

OJ220512	2 BA	BZP	1000
OJ357744	4 BA	BZP	1000
OJ220499	2 BA	SC	1000

Brass BA Hexagon Full Nuts

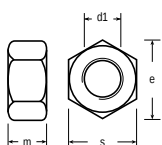

d1	2BA
m	0.167
e	0.370
s	0.324

Product Codes Begin **Q60573** Product Group **3510**

HX281049	2 BA	500
----------	------	-----



Metric Type P Nylon Insert Nuts DIN 982 Grade [8]

Note: BZP CR3.

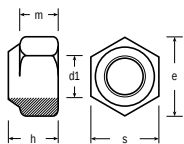

d1	M5	M6	M8	M10	M12	M14	M16	M20	M24
h	6.3	8	9.5	11.5	14	16	18	22	28
m	4.4	4.9	6.44	8.04	10.37	12.1	14.1	16.9	20.2
s	8	10	13	17	19	22	24	30	36
e min.	8.79	11.05	14.38	18.9	21.1	24.49	30	32.95	39.55

Carton

Product Codes Begin **NIPMC** Product Group 4

Article No.	Size	Finish	Box Qty.
OJ361406	M5	BZP	15000
OJ361413	M6	BZP	8000
OJ361420	M8	BZP	4000

OJ361437	M10	BZP	1800
OJ361444	M12	BZP	1200
OJ361451	M14	BZP	800

OJ361468	M16	BZP	600
OJ361475	M20	BZP	300
OJ282954	M24	BZP	150

Small Box

Product Codes Begin **NIPMS** Product Group 4

OJ361536	M5	BZP	1000
OJ361543	M6	BZP	200
OJ361550	M8	BZP	200
OJ361567	M10	BZP	200
OJ361574	M12	BZP	100

OJ361581	M14	BZP	100
OJ361598	M16	BZP	50
OJ361604	M20	BZP	25
OJ221342	M6	ZYP	500
OJ221359	M8	ZYP	250

OJ221366	M10	ZYP	250
OJ221373	M12	ZYP	200
OJ221380	M16	ZYP	100

Metric Type P Nylon Insert Nuts DIN 982 Grade [10]

Note: BZP CR3.

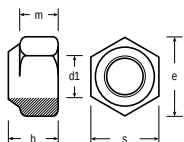

d1	M8	M10	M12	M16	M20
h	9.5	11.5	14	18	22
m	6.44	8.04	10.37	14.1	16.9
s	13	17	19	24	30
e min.	14.38	18.9	21.1	30	32.95

Product Codes Begin **NIPMSG** Product Group 4

OJ284347	M8	BZP	500
OJ284354	M10	BZP	500
OJ284361	M12	BZP	500

OJ284378	M16	BZP	200
OJ284385	M20	BZP	100

> Nuts

Metric Type T Nylon Insert Nuts DIN 985 Grade [8]*

Note: BZP CR3.

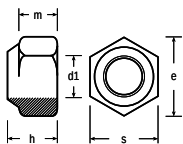

	d1	M3	M4	M5	M6	M8	M10	M12	M14	M16	M18
h	max.	4	5	5	6	8	10	12	14	16	18.5
m		2.4	2.9	3.2	4.0	5.5	6.5	8.0	9.5	10.5	13
s		5.5	7	8	10	13	17	19	22	24	27
e	max.	6.01	7.66	8.79	11.05	14.38	18.9	21.1	24.49	26.75	29.56

	M20	M22	M24	M27	M30	M33	M36	M42	M48
20	22	24	27	30	33	36	42	48	
14	15	15	17	19	22	25	29	36	
30	34	36	41	46	50	55	60	69	
32.95	35.03	39.55	45.2	50.85	55.37	60.79	72.09	82.6	

Carton

Product Codes Begin **NITMC** Product Group 4

Article No.	Size	Finish	Box Qty.
OJ677040	M4	BZP	24000
OJ362052	M5	BZP	20000
OJ362069	M6	BZP	11000
OJ362076	M8	BZP	5000

OJ362083	M10	BZP	2000
OJ362090	M12	BZP	1500
OJ362106	M14	BZP	850
OJ362113	M16	BZP	700

OJ362137	M20	BZP	320
OJ362151	M24	BZP	200
OJ362175	M30	BZP	100

Small Box

Product Codes Begin **NITMS** Product Group 4

OJ362366	M3	BZP	1000
OJ041025	M4	BZP	1000
OJ508047	M5	BZP	1000
OJ243061	M6	BZP	200
OJ243078	M8	BZP	200
OJ243085	M10	BZP	200
OJ243092	M12	BZP	100

OJ362373	M14	BZP	100
OJ144580	M16	BZP	50
OJ222264	M18	BZP	50
OJ144597	M20	BZP	25
OJ222745	M22	BZP	25
OJ362403	M24	BZP	25
OJ222271	M27	BZP	10

OJ362410	M30	BZP	10
OJ222752	M33	BZP	10
OJ222288	M36	BZP	5
OJ222295	M42	BZP	5
OJ222769	M48	BZP	5

* Sizes M20 and above are Class 6

Metric Type T Nylon Insert Nuts DIN 985 Grade [10]

Note: BZP CR3.

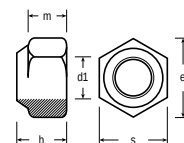

	d1	M6	M8	M10	M12	M16	M18	M20	M22	M24	M27	M30	M36
h	max.	6	8	10	12	16	18.5	20	22	24	27	30	36
m		4.0	5.5	6.5	8.0	10.5	13	14	15	15	17	19	25
s		10	13	17	19	24	27	30	34	36	41	46	55
e	max.	11.05	14.38	18.9	21.1	26.75	29.56	32.95	35.03	39.55	45.2	50.85	60.79

Product Codes Begin **NITMSG** Product Group 4

OJ284392	M6	BZP	500
OJ284408	M8	BZP	500
OJ222837	M10	BZP	200
OJ222844	M12	BZP	100
OJ465999	M14	BZP	200
OJ222851	M16	BZP	50
OJ284453	M18	BZP	200

OJ222875	M20	BZP	25
OJ284477	M22	BZP	100
OJ284484	M24	BZP	50
OJ284507	M27	BZP	25
OJ284514	M30	BZP	25
OJ284521	M36	BZP	25
OJ284415	M8	HDG	500

OJ284422	M10	HDG	500
OJ284439	M12	HDG	500
OJ284446	M16	HDG	200
OJ284460	M20	HDG	200
OJ284491	M24	HDG	50



Metric Type T Fine Pitch Nylon Insert Nuts DIN 985 **Grade [8]**

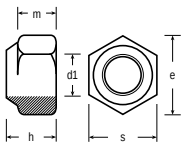

d1	M10	M12	M16	M20	M24
m	10	12	16	20	24
h	6.5	8	10.5	14.0	15.0
s	17	19	24	30	36
e	18.90	21.10	26.75	32.95	39.55

Product Codes Begin **NITMSF** Product Group 4

Article No.	Size	Finish	Box Qty.
OJ222776	M10×1.00	BZP	200
OJ222783	M10×1.25	BZP	200
OJ222790	M12×1.25	BZP	100
OJ362458	M12×1.50	BZP	100

OJ222806	M16×1.50	BZP	50
OJ222813	M20×1.50	BZP	25
OJ222820	M24×2.00	BZP	25

Metric Type T Fine Pitch Nylon Insert Nuts DIN 985 **Grade [10]**

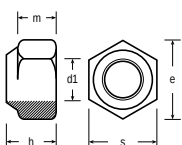

d1	M12	M16	M20	M24
m	12	16	20	24
h	8	10.5	14.0	15.0
s	19	24	30	36
e	21.10	26.75	32.95	39.55

Product Codes Begin **NITMSFGT** Product Group 4

OJ284538	M12×1.50	BZP	200
OJ284545	M16×1.50	BZP	200
OJ284552	M20×1.50	BZP	100

OJ284569	M22×1.50	BZP	100
OJ284576	M24×2.00	BZP	50

UNC Type P Nylon Insert Nuts

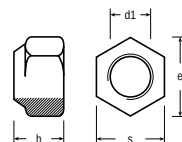

d1	1/4"	5/16"	3/8"	1/2"	5/8"	3/4"	7/8"	1"	1.1/4"	1.1/2"
e	0.505	0.577	0.650	0.866	1.083	1.299	1.516	1.732	2.165	1.598
s	0.439	0.502	0.564	0.752	0.939	1.125	1.312	1.500	1.875	2.250
h	0.327	0.359	0.468	0.609	0.765	0.880	1.015	1.015	1.365	1.624

Product Codes Begin **NIPCS** Product Group 4

Article No.	Size	Finish	Grade/Spec	Box Qty.
OJ360980	1/4 - 20UNC	BZP	NEP	200
OJ360997	5/16 - 18UNC	BZP	NEP	200
OJ361000	3/8 - 16UNC	BZP	NEP	200
OJ361024	1/2 - 13UNC	BZP	NEP	100
OJ361031	5/8 - 11UNC	BZP	NEP	50

OJ361048	3/4 - 10UNC	BZP	NEP	25
OJ221250	7/8 - 9UNC	BZP	BS4929	5
OJ221267	1 - 8UNC	BZP	BS4929	5
OJ221281	1.1/4 - 7UNC	BZP	BS4929	5
OJ221298	1.1/2 - 6UNC	BZP	BS4929	5

> Nuts

UNF Type P Nylon Insert Nuts

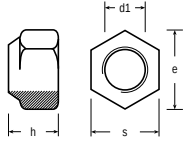

d1	1/4"	5/16"	3/8"	7/16"	1/2"	9/16"	5/8"	3/4"	7/8"	1"	1.1/4"	1.1/2"
e	0.505	0.577	0.650	0.716	0.866	1.016	1.083	1.299	1.516	1.732	2.165	1.598
s	0.439	0.502	0.564	0.620	0.752	0.870	0.939	1.125	1.312	1.500	1.875	2.250
h	0.327	0.359	0.468	0.450	0.609	0.640	0.765	0.880	1.015	1.015	1.365	1.624

Product Codes Begin **NIPFS** Product Group 4

Article No.	Size	Finish	Grade/Spec	Box Qty.					
OJ361260	1/4 - 28UNF	BZP	NEP	200	OJ361338	5/8 - 18UNF	BZP	NEP	50
OJ361277	5/16 - 24UNF	BZP	NEP	200	OJ361345	3/4 - 16UNF	BZP	NEP	25
OJ361284	3/8 - 24UNF	BZP	NEP	200	OJ221304	7/8 - 14UNF	BZP	BS4929	5
OJ361291	7/16 - 20UNF	BZP	NEP	100	OJ361376	1 - 12TPI	BZP	BS4929	5
OJ361314	1/2 - 20UNF	BZP	NEP	100	OJ221328	1.1/4 UNF - 12TPI	BZP	BS4929	5
OJ222738	9/16 - 18UNF	BZP	NEP	100	OJ221335	1.1/2 UNF - 12TPI	BZP	BS4929	5



Metric Locknuts (Half Nuts)

Note: BZP CR3.

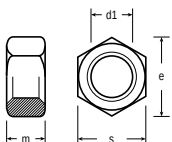

	d1	M4	M5	M6	M8	M10	M12	M14	M16	M20	M24	M30
e	min.		8.79	11.05	14.38	18.90	21.10	24.49	26.75	32.95	39.55	50.85
m	max.	2.10	2.7	3.2	4.0	5.0	6.0	7.0	8.0	10.0	12.0	15.0
s		7	8	10	13	17	19	22	24	30	36	46

Carton

Product Codes Begin **NFLMC** Product Group 4

Article No.	Size	Finish	Grade/Spec	Box Qty.					
OJ360331	M5	BZP	DIN 439B CL 4	25000	OJ360393	M20	BZP	DIN 936 CL17H	700
OJ360348	M6	BZP	DIN 439B CL 4	15000	OJ360232	M8	SC	DIN 936 CL 4	6500
OJ360355	M8	BZP	DIN 936 CL 4	6500	OJ360249	M10	SC	DIN 936 CL 4	3000
OJ360362	M10	BZP	DIN 936 CL 4	3000	OJ360256	M12	SC	DIN 936 CL 4	2000
OJ360379	M12	BZP	DIN 936 CL 4	2000	OJ360270	M16	SC	DIN 439B CL 4	1300
OJ360386	M16	BZP	DIN 439B CL 4	1300	OJ360287	M20	SC	DIN 936 CL17H	700

Small Box

Product Codes Begin **NFLMS** Product Group 4

OJ221090	M4	BZP	DIN 439B CL 4	1000	OJ360423	M5	SC	DIN 439B CL 4	1000
OJ360515	M5	BZP	DIN 439B CL 4	1000	OJ360430	M6	SC	DIN 439B CL 4	1000
OJ360522	M6	BZP	DIN 439B CL 4	1000	OJ360447	M8	SC	DIN 936 CL 4	500
OJ360539	M8	BZP	DIN 936 CL 4	500	OJ360454	M10	SC	DIN 936 CL 4	500
OJ360546	M10	BZP	DIN 936 CL 4	500	OJ360461	M12	SC	DIN 936 CL 4	250
OJ360553	M12	BZP	DIN 936 CL 4	250	OJ221052	M14	SC	DIN 936 CL 4	200
OJ221106	M14	BZP	DIN 936 CL 4	200	OJ360478	M16	SC	DIN 439B CL 4	100
OJ360560	M16	BZP	DIN 439B CL 4	100	OJ360485	M20	SC	DIN 936 CL17H	100
OJ360577	M20	BZP	DIN 936 CL17H	100	OJ221069	M24	SC	DIN 936 CL17H	50
OJ221113	M24	BZP	DIN 936 CL17H	50	OJ221076	M30	SC	DIN 936 CL17H	25
OJ221120	M30	BZP	DIN 936 CL17H	25					

Brass Metric Locknuts (Half Nuts) DIN 439B

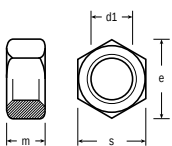

	d1	M4	M5	M6	M8	M10	M12
m		2.20	2.70	3.20	4.0	5.0	6.0
e		7.66	8.79	11.05	14.38	18.9	21.21
s		7	8	10	13	17	19

Product Codes Begin **Q60439** Product Group 3506

Article No.	Size	Box Qty.			
HX287546	M3	2000	HX287584	M8	500
HX287553	M4	2000	HX287591	M10	200
HX287560	M5	1000	HX287607	M12	200
HX287577	M6	1000			

> Nuts

UNC Locknuts BS1768

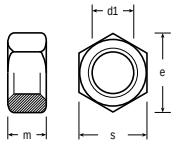

	d1	1/4"	5/16"	1/2"	9/16"	5/8"	3/4"
m max.		0.163	0.195	0.323	0.340	0.387	0.446
e max.		0.505	0.577	0.866		1.083	1.299
s max.		0.438	0.500	0.750	0.870	0.938	1.125

Product Codes Begin **NFLCS** Product Group **4**

Article No.	Size	Finish	Box Qty.
OJ220888	1/4 - 20UNC	SC	500
OJ220895	5/16 - 18UNC	SC	500
OJ220925	1/2 - 13UNC	SC	100
OJ220932	5/8 - 11UNC	SC	75
OJ220949	3/4 - 10UNC	SC	50

UNF Locknuts BS1768

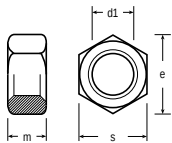

	d1	1/4"	5/16"	3/8"	7/16"	1/2"	9/16"	5/8"	3/4"
m max.		0.163	0.195	0.227	0.255	0.323	0.340	0.387	0.446
e max.		0.505	0.577	0.650	0.794	0.866		1.083	1.299
s max.		0.438	0.500	0.562	0.687	0.750	0.870	0.938	1.125

Product Codes Begin **NFLFS** Product Group **4**

OJ220956	1/4 - 28UNF	SC	500	OJ220994	1/2 - 20UNF	SC	100
OJ220963	5/16 - 24UNF	SC	500	OJ221007	9/16 - 18UNF	SC	75
OJ220970	3/8 - 24UNF	SC	250	OJ221014	5/8 - 18UNF	SC	75
OJ220987	7/16 - 20UNF	SC	100	OJ221021	3/4 - 16UNF	SC	50

BZP Binx Nuts

All Metal Locking Nuts

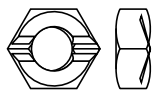

Product Codes Begin **NBM** Product Group **18**

Article No.	Size	Box Qty.
OJ246758	M3	1000
OJ246772	M5	1000
OJ246789	M6	1000
OJ246796	M8	1000
OJ246802	M10	200
OJ246819	M12	100
OJ246833	M16	100
OJ246840	M20	100
OJ246857	M24	100
OJ246864	M30	50



BZP Unserrated Flange Nuts DIN 6923

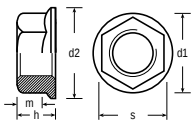

	d1	M5	M6	M8
d2 max.		11.8	14.2	17.9
h max.		6.2	7.3	9.4
m		4.7	5.7	7.6
s		8	10	13

Product Codes Begin **NXFNR** Product Group 4

Article No.	Size	Box Qty.
OJ139661	M5	4000
OJ139678	M6	3000
OJ139685	M8	1500

BZP Serrated Flange Nuts DIN 6923

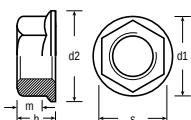

	d1	M5	M6	M8	M10	M12
d2 max.		11.8	14.2	17.9	21.8	26.0
h max.		6.2	7.3	9.4	11.4	13.8
m		4.7	5.7	7.6	9.6	11.6
s		8	10	13	15	18

Product Codes Begin **NXFSR** Product Group 4

OJ572949	M4	5000	OJ139630	M8	1500
OJ139616	M5	4000	OJ139647	M10	1000
OJ139623	M6	3000	OJ139654	M12	500



BZP Square Roofing Nuts

Product Codes Begin **NXRNM** Product Group 4

OJ139692	M5 10×3	5000	OJ139739	M8 13×5	2000
OJ139708	M6 11×4	3000	OJ139746	M10 17×5	1000

SC Hexagon Weld Nut DIN 929

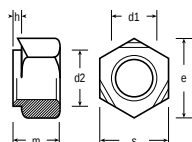

	d1	M5	M6	M8	M10
d2 max.		7	8	10.5	12.5
e max.		10.95	12.02	15.38	18.74
m		4	5	6.5	8
s		10	11	14	17
h		0.7	0.75	0.9	1.15

Product Codes Begin **NXWRDM** Product Group 4

OJ139753	M5	4000	OJ139777	M8	2000
OJ139760	M6	3000	OJ139784	M10	1000

> Nuts

SC Square Weld Nut DIN 928

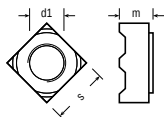

	d1	M5	M6	M8	M10
m max.		4.20	5.00	6.50	8.00
s max.		9.00	10.00	14.00	17.00

Product Codes Begin **NXWSRDM** Product Group 4

Article No.	Size	Box Qty.			
OJ139791	M5	4000	OJ139814	M8	2000
OJ139807	M6	3000	OJ139821	M10	1000

BZP Metric Dome Nuts

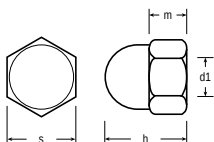

	d1	M3	M4	M5	M6	M8	M10	M12	M16	M20
s max.		5.50	7.00	8.00	10.00	13.00	17.00	19.00	24.00	30.00
h max.		5.00	7.00	8.00	10.00	12.00	16.00	19.00	24.00	27.00

Product Codes Begin **ESDNSZM** Product Group 47

OJ346366	M3	500	OJ346403	M6	200	OJ346465	M12	50
OJ346373	M4	500	OJ346427	M8	100	OJ346489	M16	50
OJ346380	M5	200	OJ346441	M10	100	OJ346502	M20	25



BZP Metric Steel Dome Nuts DIN 1587

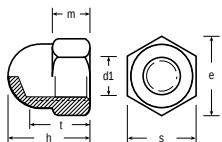

	d1	M5	M6	M8	M10	M12	M16
h		10	12	15	18	22	28
t min.		7.21	7.71	10.65	12.65	15.65	20.58
m max.		4.0	5.0	6.5	8.0	10.0	13.0
s		8.0	10.0	13.0	17.0	19.0	24.0
e min.		8.79	11.05	14.38	18.9	21.1	26.75

Carton

Product Codes Begin **ESDNCZM** Product Group **47**

Article No.	Size	Box Qty.			
OJ346151	M5	12000	OJ346212	M10	1500
OJ346175	M6	5000	OJ346236	M12	1000
OJ346199	M8	2500	OJ346250	M16	500

Small Box

Product Codes Begin **ESDNSZM** Product Group **47**

OJ346397	M5	200	OJ346458	M10	100
OJ346410	M6	200	OJ346472	M12	50
OJ346434	M8	100	OJ346496	M16	50

Brass Metric Dome Nuts DIN 1587

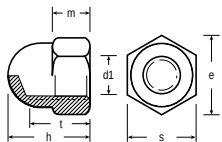

	d1	M3	M4	M5	M8	M10	M12
h		6	8	10	15	18	22
t min.		3.6	5.26	7.21	10.65	12.65	15.65
m max.		2.4	3.2	4.0	6.5	8.0	10.0
s		5.5	7.0	8.0	13.0	17.0	19.0
e min.		6.08	7.66	8.79	14.38	18.9	21.1

Product Codes Begin **Q601587** Product Group **3506**

HX287386	M3	2000	HX287423	M8	200
HX287393	M4	2000	HX287430	M10	200
HX287409	M5	1000	HX287447	M12	100
HX725048	M6	500			



Nylon Insert Flange Nuts DIN 6926

Product Codes Begin **NIFMS** Product Group **4**

OJ475844	M5	2000	OJ475875	M10	200
OJ475851	M6	1000	OJ475882	M12	200
OJ475868	M8	1000			



BZP Stover Locking Nuts DIN 980V

Product Codes Begin **NLS** Product Group **4**

OJ578507	M6	1000	OJ578538	M12	200
OJ578514	M8	1000	OJ578545	M16	100
OJ578521	M10	200	OJ578552	M20	50

Nuts

BZP 4 Pronged Tee Nuts



Carton

Product Codes Begin **EPTNCM** Product Group **47**

Article No.	Size	Box Qty.						
OJ345376	M4 × 8mm	10000	OJ345406	M6 × 9mm	5000	OJ345437	M8 × 11mm	3000
OJ345383	M5 × 9mm	7000	OJ345413	M6 × 12.3mm	4000	OJ345444	M8 × 17.5mm	2000
OJ345390	M5 × 11mm	7000	OJ345420	M6 × 15.5mm	4000	OJ345451	M10 × 13mm	2000

Small Box

OJ345536	M4 × 8mm	200	OJ345567	M6 × 12.3mm	200	OJ345598	M8 × 17.5mm	100
OJ345543	M5 × 9mm	200	OJ345574	M6 × 15.5mm	200	OJ345604	M10 × 13mm	100
OJ345550	M6 × 9mm	200	OJ345581	M8 × 11mm	100			

BZP Wing Nuts

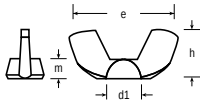

d1	M3	M4	M5	M6	M8	M10	M12	M16
m	3.00	3.00	4.00	4.30	5.40	6.30	7.90	10.60
e	18.50	18.50	22.00	25.00	30.30	35.30	47.50	65.00
h	8.80	8.80	10.50	12.20	14.80	17.30	22.50	30.80

Product Codes Begin **ESWNSZ** Product Group **47**

Article No.	Size	Box Qty.			
OJ347042	M3	200	OJ508719	M8	100
OJ347059	M4	200	OJ508726	M10	250
OJ508696	M5	200	OJ347066	M12	100
OJ508702	M6	200	OJ220451	M16	50

Brass Wing Nuts DIN 315

Product Codes Begin **Q603150** Product Group **3506**

HX287454	M5	100	HX287478	M8	50
HX287461	M6	100	HX725055	M10	100



Self Colour Hank Rivet Bushes

Hexagon

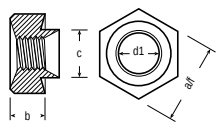

d1	M3	M4	M5	M6	M8	M10	M12
a/f	7.92	7.92	9.52	11.10	14.28	19.05	22.22
b	3.18	3.18	3.81	5.08	6.35	7.62	10.16
c	5.54	6.73	7.92	9.52	12.70	15.88	19.05

Product Codes Begin **HSMH** Product Group **33**

Article No.	Size	Box Qty.
OJ347127	M4 × 10g	500
OJ347134	M4 × 14g	500
OJ347141	M4 × 16g	500
OJ347172	M5 × 10g	500
OJ347196	M5 × 14g	500
OJ347202	M5 × 16g	500
OJ347219	M5 × 18g	500

OJ347233	M6 × 10g	500
OJ347257	M6 × 14g	500
OJ347264	M6 × 16g	500
OJ347271	M6 × 18g	500
OJ347288	M6 × 20g	500
OJ347295	M8 × 10g	100
OJ347301	M8 × 12g	100

OJ347318	M8 × 14g	100
OJ347325	M8 × 16g	100
OJ347349	M10 × 10g	100
OJ347363	M10 × 14g	100
OJ347370	M10 × 16g	100
OJ347387	M10 × 18g	100
OJ347400	M12 × 14g	100

Round

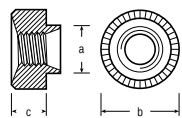

d1	M3	M4	M5	M6	M8	M10
a	.218	.265	.312	.375	.500	.625
b	.312	.375	.437	.500	.625	.750
c	.125	.125	.150	.200	.250	.300

Product Codes Begin **HSMR** Product Group **33**

OJ347417	M3 × 16g	500
OJ347455	M4 × 16g	500
OJ347462	M4 × 18g	500
OJ347479	M4 × 20g	500
OJ347509	M5 × 16g	500

OJ347530	M6 × 10g	500
OJ347554	M6 × 14g	500
OJ347561	M6 × 16g	500
OJ347578	M6 × 18g	500
OJ347592	M8 × 10g	100

OJ347615	M8 × 14g	100
OJ347622	M8 × 16g	100
OJ347639	M10 × 10g	100
OJ126388	M10 × 14g	100



Self Clinching Fasteners

Self Clinching Nuts - Hardened Carbon Steel



Product Codes Begin **PESSMS** Product Group **27**

Article No.	Size	Box Qty.
SS-M5-0ZI	SS-M5-0ZI	200
SS-M5-1ZI	SS-M5-1ZI	200
SS-M5-2ZI	SS-M5-2ZI	200

Self Clinching Nuts - Carbon Steel Zinc Plated



Product Codes Begin **PEMSM** Product Group **27**

S-M2.5-0ZI	S-M2.5-0ZI	500	S-M4-1ZI	S-M4-1ZI	500
S-M2.5-1ZI	S-M2.5-1ZI	500	S-M4-2ZI	S-M4-2ZI	500
S-M2.5-2ZI	S-M2.5-2ZI	500	S-M6-0ZI	S-M6-0ZI	200
S-M3.5-0ZI	S-M3.5-0ZI	500	S-M6-1ZI	S-M6-1ZI	200
S-M3.5-1ZI	S-M3.5-1ZI	500	S-M6-2ZI	S-M6-2ZI	200
S-M3.5-2ZI	S-M3.5-2ZI	500	S-M8-1ZI	S-M8-1ZI	200
S-M3-0ZI	S-M3-0ZI	500	S-M8-2ZI	S-M8-2ZI	200
S-M3-1ZI	S-M3-1ZI	500	S-M10-1ZI	S-M10-1ZI	100
S-M3-2ZI	S-M3-2ZI	500	S-M10-2ZI	S-M10-2ZI	100
S-M4-0ZI	S-M4-0ZI	500			

Self Clinching Nuts - Hardened Stainless Steel



Product Codes Begin **PEMSPM** Product Group **27**

SP-M3-0	SP-M3-0	500	SP-M4-2	SP-M4-2	500
SP-M3-1	SP-M3-1	500	SP-M5-1	SP-M5-1	200
SP-M3-2	SP-M3-2	500	SP-M5-2	SP-M5-2	200
SP-M4-0	SP-M4-0	500	SP-M6-1	SP-M6-1	200
SP-M4-1	SP-M4-1	500			

Self Clinching Nuts - 300 Series Stainless Steel



Product Codes Begin **PEMCLSM** Product Group **27**

CLS-M2.5-0	CLS-M2.5-0	500	CLS-M6-1	CLS-M6-1	200
CLS-M3-0	CLS-M3-0	500	CLS-M6-2	CLS-M6-2	200
CLS-M3-1	CLS-M3-1	500	CLS-M8-1	CLS-M8-1	200
CLS-M3-2	CLS-M3-2	500	CLS-M8-2	CLS-M8-2	200
CLS-M4-0	CLS-M4-0	500	CLSS-M5-0	CLSS-M5-0	200
CLS-M4-1	CLS-M4-1	500	CLSS-M5-1	CLSS-M5-1	200
CLS-M4-2	CLS-M4-2	500	CLSS-M5-2	CLSS-M5-2	200



Self Clinching Flush Nuts - 300 Series Stainless Steel

Product Codes Begin **PEMFM** Product Group **27**

F-M2.5-1	F-M2.5-1	500
F-M2.5-2	F-M2.5-2	500
F-M3-1	F-M3-1	500
F-M3-2	F-M3-2	500
F-M4-1	F-M4-1	500
F-M4-2	F-M4-2	500
F-M5-1	F-M5-1	200
F-M6-3	F-M6-3	200



Self Clinching Flush Head Studs - Heat Treated Carbon Steel

Product Codes Begin **PEMFHM** Product Group **27**

FH-M2.5-10ZI	FH-M2.5-10ZI	500	FH-M4-35ZI	FH-M4-35ZI	500
FH-M2.5-12ZI	FH-M2.5-12ZI	500	FH-M4-6ZI	FH-M4-6ZI	500
FH-M2.5-15ZI	FH-M2.5-15ZI	500	FH-M4-8ZI	FH-M4-8ZI	500
FH-M2.5-18ZI	FH-M2.5-18ZI	500	FH-M5-10ZI	FH-M5-10ZI	200
FH-M2.5-6ZI	FH-M2.5-6ZI	500	FH-M5-12ZI	FH-M5-12ZI	200
FH-M2.5-8ZI	FH-M2.5-8ZI	500	FH-M5-15ZI	FH-M5-15ZI	200
FH-M3-10ZI	FH-M3-10ZI	500	FH-M5-16ZI	FH-M5-16ZI	200
FH-M3-12ZI	FH-M3-12ZI	500	FH-M5-18ZI	FH-M5-18ZI	200
FH-M3-15ZI	FH-M3-15ZI	500	FH-M5-20ZI	FH-M5-20ZI	200
FH-M3-16ZI	FH-M3-16ZI	500	FH-M5-25ZI	FH-M5-25ZI	200
FH-M3-18ZI	FH-M3-18ZI	500	FH-M5-30ZI	FH-M5-30ZI	200
FH-M3-20ZI	FH-M3-20ZI	500	FH-M5-8ZI	FH-M5-8ZI	200
FH-M3-22ZI	FH-M3-22ZI	500	FH-M6-10ZI	FH-M6-10ZI	200
FH-M3-25ZI	FH-M3-25ZI	500	FH-M6-12ZI	FH-M6-12ZI	200
FH-M3-30ZI	FH-M3-30ZI	500	FH-M6-15ZI	FH-M6-15ZI	200
FH-M3-35ZI	FH-M3-35ZI	500	FH-M6-16ZI	FH-M6-16ZI	200
FH-M3-6ZI	FH-M3-6ZI	500	FH-M6-18ZI	FH-M6-18ZI	200
FH-M3-8ZI	FH-M3-8ZI	500	FH-M6-20ZI	FH-M6-20ZI	200
FH-M4-10ZI	FH-M4-10ZI	500	FH-M6-25ZI	FH-M6-25ZI	200
FH-M4-12ZI	FH-M4-12ZI	500	FH-M6-30ZI	FH-M6-30ZI	200
FH-M4-15ZI	FH-M4-15ZI	500	FH-M6-35ZI	FH-M6-35ZI	200
FH-M4-16ZI	FH-M4-16ZI	500	FH-M8-15ZI	FH-M8-15ZI	200
FH-M4-18ZI	FH-M4-18ZI	500	FH-M8-18ZI	FH-M8-18ZI	200
FH-M4-20ZI	FH-M4-20ZI	500	FH-M8-20ZI	FH-M8-20ZI	200
FH-M4-22ZI	FH-M4-22ZI	500	FH-M8-25ZI	FH-M8-25ZI	200
FH-M4-25ZI	FH-M4-25ZI	500	FH-M8-30ZI	FH-M8-30ZI	200
FH-M4-30ZI	FH-M4-30ZI	500	FH-M8-35ZI	FH-M8-35ZI	100



Self Clinching Flush Head Studs - 300 Series Stainless Steel

Product Codes Begin **PEMFHSM** Product Group **27**

FHS-M3-10	FHS-M3-10	500	FHS-M5-12	FHS-M5-12	200
FHS-M3-12	FHS-M3-12	500	FHS-M5-15	FHS-M5-15	200
FHS-M3-15	FHS-M3-15	500	FHS-M5-18	FHS-M5-18	200
FHS-M3-16	FHS-M3-16	500	FHS-M5-20	FHS-M5-20	200
FHS-M3-18	FHS-M3-18	500	FHS-M5-25	FHS-M5-25	200
FHS-M3-20	FHS-M3-20	500	FHS-M6-10	FHS-M6-10	200
FHS-M3-30	FHS-M3-30	500	FHS-M6-12	FHS-M6-12	200
FHS-M3-8	FHS-M3-8	500	FHS-M6-15	FHS-M6-15	200
FHS-M4-10	FHS-M4-10	500	FHS-M6-18	FHS-M6-18	200
FHS-M4-12	FHS-M4-12	500	FHS-M6-20	FHS-M6-20	200
FHS-M4-15	FHS-M4-15	500	FHS-M6-25	FHS-M6-25	200
FHS-M4-16	FHS-M4-16	500	FHS-M6-30	FHS-M6-30	200
FHS-M4-18	FHS-M4-18	500	FHS-M8-15	FHS-M8-15	200
FHS-M4-20	FHS-M4-20	500	FHS-M8-18	FHS-M8-18	200
FHS-M4-25	FHS-M4-25	500	FHS-M8-20	FHS-M8-20	200
FHS-M4-6	FHS-M4-6	500	FHS-M8-25	FHS-M8-25	200
FHS-M4-8	FHS-M4-8	500	FHS-M8-30	FHS-M8-30	200
FHS-M5-10	FHS-M5-10	200			



Self Clinching Flush Head Pilot Pins - 300 Series Stainless Steel

Product Codes Begin **PEMTPS** Product Group **27**

TPS-4MM-10	TPS-4MM-10	500	TPS-5MM-20	TPS-5MM-20	200
TPS-4MM-8	TPS-4MM-8	500	TPS-6MM-12	TPS-6MM-12	200
TPS-5MM-12	TPS-5MM-12	200	TPS-6MM-16	TPS-6MM-16	200
TPS-5MM-16	TPS-5MM-16	200			



Washers

DIN 125A

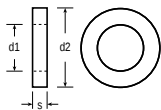

d1	M3	M4	M5	M6	M8	M10	M12	M14	M16
d2 max.	7	9	10	12	16	20	24	28	30
s nom.	0.5	0.8	1.0	1.6	1.6	2.0	2.5	2.5	3.0

M18	M20	M22	M24	M27	M30	M33	M36	M39
34	37	39	44	50	56	60	66	72
3.0	3.0	3.0	4.0	4.0	4.0	5.0	5.0	6.0

Carton

Product Codes Begin **WSA D** Product Group **40**

Article No.	Size	Finish	Box Qty.
OJ369822	M3	BZP	180000
OJ369839	M4	BZP	75000
OJ369846	M5	BZP	50000
OJ369853	M6	BZP	22000
OJ369860	M8	BZP	10000
OJ369877	M10	BZP	6000
OJ369884	M12	BZP	3500
OJ369891	M14	BZP	2500
OJ369907	M16	BZP	2000

OJ369914	M18	BZP	1500
OJ369921	M20	BZP	1200
OJ369938	M22	BZP	1200
OJ369945	M24	BZP	700
OJ369952	M27	BZP	500
OJ369969	M30	BZP	400
OJ369976	M36	BZP	200
OJ676234	M10	Galv	6000
OJ369983	M12	Galv	3500

OJ369990	M16	Galv	2000
OJ370002	M20	Galv	1200
OJ370019	M24	Galv	700
OJ676241	M30	Galv	400
OJ676258	M36	Galv	200
OJ677088	M16	SC	2000
OJ677095	M20	SC	1200
OJ677101	M24	SC	700

Small Box

OJ564302	M2	BZP	10000
OJ564319	M2.5	BZP	5000
OJ125305	M3	BZP	500
OJ504674	M3.5	BZP	500
OJ125312	M4	BZP	500
OJ125329	M5	BZP	200
OJ125336	M6	BZP	200
OJ125343	M8	BZP	200
OJ125350	M10	BZP	200
OJ125367	M12	BZP	200
OJ128610	M14	BZP	200
OJ125374	M16	BZP	100
OJ125381	M20	BZP	100
OJ128627	M24	BZP	50
OJ128634	M30	BZP	50

OJ411736	M8	Galv	500
OJ272689	M10	Galv	200
OJ272696	M12	Galv	200
OJ272702	M16	Galv	100
OJ272719	M20	Galv	100
OJ272726	M24	Galv	50
OJ272733	M30	Galv	50
OJ272740	M36	Galv	25
OJ125398	M3	ZYP	500
OJ125404	M4	ZYP	500
OJ125411	M5	ZYP	200
OJ125428	M6	ZYP	200
OJ125435	M8	ZYP	200
OJ125442	M10	ZYP	200
OJ125459	M12	ZYP	200

OJ125466	M16	ZYP	100
OJ125480	M20	ZYP	100
OJ125213	M3	SC	500
OJ125220	M4	SC	500
OJ125237	M5	SC	200
OJ125244	M6	SC	200
OJ125251	M8	SC	200
OJ125268	M10	SC	200
OJ125275	M12	SC	200
OJ125282	M16	SC	100
OJ125299	M20	SC	100
OJ564289	M24	SC	50
OJ564296	M30	SC	50
OJ282664	M33	SC	25
OJ282671	M36	SC	25

EN ISO 7089-200 HV

Note: BZP

OJ506265	M4	BZP	1000
OJ506272	M5	BZP	1000
OJ506289	M6	BZP	1000
OJ506296	M8	BZP	1000
OJ506302	M10	BZP	1000

OJ506319	M12	BZP	500
OJ506326	M14	BZP	500
OJ506333	M16	BZP	500
OJ506340	M18	BZP	500
OJ506357	M20	BZP	200

OJ506364	M20	BZP	200
OJ506371	M24	BZP	200
OJ506388	M27	BZP	100
OJ506395	M30	BZP	100
OJ506401	M36	BZP	50

Form B BS4320B

Note: BZP CR3.

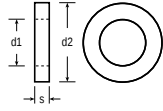

	d1	M5	M6	M8	M10	M12	M16	M20	M24	M30	M36
d2	max.	10	12.5	17	21	24	30	37	44	56	66
s	nom.	0.8	0.9	1.1	1.45	1.8	2.2	2.2	2.7	2.7	3.3

Carton

Product Codes Begin **WSB D** Product Group **40**

Article No.	Size	Finish	Box Qty.				
OJ236049	M5	BZP	70000	OJ235158	M12	BZP	5000
OJ236056	M6	BZP	40000	OJ235172	M16	BZP	3000
OJ236063	M8	BZP	18000	OJ235196	M20	BZP	1800
OJ235141	M10	BZP	8000	OJ236070	M24	BZP	1200

Small Box

OJ235462	M5	BZP	1000	OJ235493	M12	BZP	200	OJ282688	M30	BZP	50
OJ235479	M6	BZP	1000	OJ235165	M16	BZP	100	OJ282695	M36	BZP	25
OJ235486	M8	BZP	500	OJ235189	M20	BZP	100				
OJ235134	M10	BZP	500	OJ235509	M24	BZP	100				

Form C BS4320C

Note: BZP CR3.

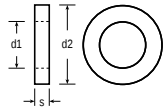

	d1	M5	M6	M8	M10	M12	M14	M16	M20	M24
d2	max.	12.5	14.0	21.0	24.0	28.0	30.0	34.0	39.0	50.0
s	nom.	1.0	1.5	1.6	2.0	2.5	2.5	3.0	3.0	4.0

Carton

Product Codes Begin **WSC D** Product Group **40**

OJ235202	M5	BZP	25000	OJ677118	M14	BZP	2000
OJ206295	M6	BZP	15000	OJ169774	M16	BZP	1600
OJ169743	M8	BZP	6000	OJ169781	M20	BZP	1300
OJ169750	M10	BZP	4000	OJ169804	M24	BZP	550
OJ169767	M12	BZP	2000				

Small Box

OJ236087	M5	BZP	1000	OJ235233	M12	BZP	200
OJ236094	M6	BZP	1000	OJ236100	M16	BZP	100
OJ235219	M8	BZP	500	OJ235240	M20	BZP	100
OJ235226	M10	BZP	200	OJ236117	M24	BZP	50



Form A Brass Flat Washer

DIN 125A

Product Codes Begin **Q60125** Product Group **3506**

Article No.	Size	Box Qty.
HX287287	M2.5	1000
HX287294	M3	1000
HX287300	M3.5	1000
HX287317	M4	1000

HX287324	M5	1000
HX287331	M6	500
HX287348	M8	500
HX287355	M10	500

HX287362	M12	200
HX287379	M16	100



Form B Brass Flat Washer

BS 4320B

Product Codes Begin **Q60432** Product Group **3506**

Article No.	Size	Box Qty.
HX287492	M6	1000
HX287508	M8	500

HX287515	M10	500
HX287522	M12	200

HX287539	M16	100
----------	-----	-----

Washers

Form G BS4320G

Note: BZP CR3.

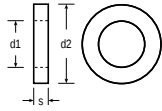

	d1	M8	M10	M12	M16	M20	M24	M30
d2 max.		24.0	30.0	36.0	48.0	60.0	72.0	90.0
s nom.		2.0	2.5	3.0	4.0	5.0	6.0	8.0

Carton

Product Codes Begin **WSG D** Product Group **40**

Article No.	Size	Finish	Box Qty.									
OJ236162	M8	BZP	4000	OJ235301	M20	BZP	200	OJ236278	M20	Galv	200	
OJ236179	M10	BZP	2100	OJ236186	M24	BZP	130	OJ236285	M24	Galv	140	
OJ235264	M12	BZP	1200	OJ236254	M12	Galv	1200	OJ236292	M30	Galv	50	
OJ235288	M16	BZP	400	OJ236261	M16	Galv	400					

Small Box

OJ236124	M8	BZP	100	OJ236148	M24	BZP	50	OJ236216	M16	Galv	50
OJ235257	M10	BZP	100	OJ236155	M30	BZP	20	OJ235332	M20	Galv	50
OJ236131	M12	BZP	100	OJ235318	M8	Galv	100	OJ236223	M24	Galv	50
OJ235271	M16	BZP	100	OJ236209	M10	Galv	100				
OJ235295	M20	BZP	50	OJ235325	M12	Galv	100				

Heavy Pattern Table 3

Note: BZP CR3.

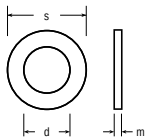

d1	1/4	5/16	3/8	7/16	1/2	5/8	3/4	7/8	1	1.1/8	1.1/4	1.1/2	2
m	17g	15g	15g	13g	13g	11g	10g	9g	8g	7g	7g	6g	5g
s	9/16	5/8	3/4	7/8	1	1.1/4	1.1/2	1.5/8	1.7/8	2.1/8	2.3/8	2.7/8	3.5/8

Product Codes Begin **WS3HS** Product Group **40**

OJ265025	1/4	BZP	500	OJ265070	5/8	BZP	100	OJ265124	1.1/4	BZP	25
OJ265032	5/16	BZP	500	OJ265087	3/4	BZP	100	OJ265131	1.1/2	BZP	25
OJ265049	3/8	BZP	500	OJ265094	7/8	BZP	50	OJ265148	2	BZP	25
OJ265056	7/16	BZP	200	OJ265100	1	BZP	50				
OJ265063	1/2	BZP	200	OJ265117	1.1/8	BZP	25				



Light Pattern Table 3

Note: BZP CR3.

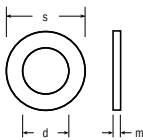

d1	1/4	5/16	3/8	1/2	5/8	3/4	1
m	20g	19g	18g	17g	15g	15g	15g
s	9/16	5/8	3/4	1	1.1/4	1.1/2	1.7/8

Product Codes Begin **WS3HS** Product Group **40**

Article No.	Size	Finish	Box Qty.				
OJ265155	1/4	BZP	500	OJ265193	5/8	BZP	200
OJ265162	5/16	BZP	500	OJ265209	3/4	BZP	100
OJ265179	3/8	BZP	500	OJ265216	1	BZP	100
OJ265186	1/2	BZP	200				

Heavy Pattern Table 4

Note: BZP CR3.

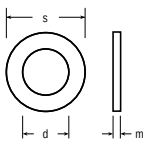

d1	1/4	5/16	3/8	7/16	1/2	5/8	3/4	7/8	1
m	17g	15g	15g	13g	13g	11g	10g	9g	8g
s	5/8	3/4	7/8	1	1.1/8	1.3/8	1.5/8	1.7/8	2.1/8

Product Codes Begin **WS4HS** Product Group **40**

OJ265223	1/4	BZP	500	OJ265278	7/16	BZP	200	OJ265322	3/4	BZP	100
OJ265230	5/16	BZP	500	OJ265292	1/2	BZP	200	OJ265339	7/8	BZP	50
OJ265254	3/8	BZP	500	OJ265315	5/8	BZP	100	OJ265346	1	BZP	50

Washers



Flat Washers Through Hardened Steel EN 14399-6 300HV

Product Codes Begin **WSH DS** Product Group **40**

Article No.	Size	Finish	Box Qty.								
OJ283760	M12	BZP	500	OJ283814	M16	Galv	200	OJ283869	M22	SC	200
OJ284880	M14	BZP	500	OJ283852	M20	Galv	200	OJ283876	M24	SC	200
OJ284897	M16	BZP	500	OJ283890	M24	Galv	200	OJ283906	M27	SC	50
OJ284903	M18	BZP	200	OJ283951	M30	Galv	50	OJ283937	M30	SC	50
OJ283845	M20	BZP	200	OJ283753	M12	SC	500	OJ283968	M33	SC	50
OJ283883	M24	BZP	200	OJ283791	M14	SC	500	OJ283975	M36	SC	50
OJ283913	M27	BZP	50	OJ283807	M16	SC	100	OJ283982	M39	SC	50
OJ283944	M30	BZP	50	OJ283821	M18	SC	200	OJ283999	M42	SC	50
OJ283784	M12	Galv	500	OJ283838	M20	SC	200	OJ284019	M48	SC	25



Steel Mudguard Washers

Carton

Product Codes Begin **WSMM** Product Group **40**

Article No.	Thickness ID OD	Finish	Box Qty.				
OJ125497	M5 × 20 × 1.5	BZP	7000	OJ125572	M8 × 30 × 1.5	BZP	3000
OJ125503	M5 × 25 × 1.5	BZP	4000	OJ125589	M8 × 40 × 1.5	BZP	1500
OJ276984	M5 × 30 × 1.5	BZP	3000	OJ125596	M8 × 50 × 1.5	BZP	1000
OJ125510	M6 × 20 × 1.5	BZP	7000	OJ125602	M10 × 25 × 1.5	BZP	5000
OJ125527	M6 × 25 × 1.5	BZP	4000	OJ125619	M10 × 30 × 1.5	BZP	3000
OJ125534	M6 × 30 × 1.5	BZP	3000	OJ125626	M10 × 40 × 1.5	BZP	1500
OJ125541	M6 × 40 × 1.5	BZP	1500	OJ125633	M10 × 50 × 1.5	BZP	1000
OJ125558	M6 × 50 × 1.5	BZP	1000	OJ125640	M12 × 38 × 1.5	BZP	1500
OJ125565	M8 × 25 × 1.5	BZP	4000	OJ125657	M12 × 50 × 1.5	BZP	1000

Small Box

OJ188041	M5 × 20 × 1.5	BZP	100	OJ188126	M8 × 30 × 1.5	BZP	100
OJ188058	M5 × 25 × 1.5	BZP	100	OJ188133	M8 × 40 × 1.5	BZP	100
OJ391403	M5 × 30 × 1.5	BZP	100	OJ188140	M8 × 50 × 1.5	BZP	100
OJ188065	M6 × 20 × 1.5	BZP	100	OJ188157	M10 × 25 × 1.5	BZP	100
OJ188072	M6 × 25 × 1.5	BZP	100	OJ188164	M10 × 30 × 1.5	BZP	100
OJ188089	M6 × 30 × 1.5	BZP	100	OJ188171	M10 × 40 × 1.5	BZP	100
OJ188096	M6 × 40 × 1.5	BZP	100	OJ188188	M10 × 50 × 1.5	BZP	100
OJ188102	M6 × 50 × 1.5	BZP	100	OJ188195	M12 × 38 × 1.5	BZP	50
OJ188119	M8 × 25 × 1.5	BZP	100	OJ188201	M12 × 50 × 1.5	BZP	50



Single Coil Spring Washers

Rectangular DIN 127B

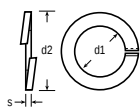

	d1	M3	M4	M5	M6	M8	M10	M12	M16	M20	M24	M30
d2 max.		5.50	7.55	8.15	11.7	14.85	18.0	21.0	27.3	33.5	39.8	43.9
s		1.00	0.9	1.2	1.6	2	2.2	2.5	3.5	4	5	6

Product Codes Begin **XSFRDS** Product Group **40**

Article No.	Size	Finish	Box Qty.									
OJ235424	M4	BZP	1000	OJ235431	M8	BZP	1000	OJ267883	M16	BZP	200	
OJ267845	M5	BZP	1000	OJ267869	M10	BZP	500	OJ267890	M20	BZP	100	
OJ267852	M6	BZP	1000	OJ267876	M12	BZP	500	OJ267906	M24	BZP	50	

Single Coil Spring Washers

Square DIN 7980

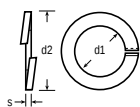

	d1	M4	M5	M6	M8	M10	M12	M16	M20	M24
d2 max.		7.0	8.8	9.9	12.7	16.0	18.0	24.4	30.6	35.9
s		1.2	1.6	1.6	2.0	2.5	2.5	3.5	4.5	5.0

Carton

Product Codes Begin **XSFSD** Product Group **40**

OJ194400	M5	BZP	60000	OJ236452	M12	BZP	8500	OJ676265	M12	HDG	10000
OJ194417	M6	BZP	55000	OJ236469	M16	BZP	3500	OJ676272	M16	HDG	4000
OJ194424	M8	BZP	20000	OJ236476	M20	BZP	1500	OJ676289	M20	HDG	2000
OJ236445	M10	BZP	10000	OJ676302	M24	BZP	1000	OJ676319	M24	HDG	1000

Small Box

OJ202600	M3	BZP	1000	OJ202679	M12	BZP	500	OJ267791	M12	HDG	500
OJ202617	M4	BZP	1000	OJ526270	M14	BZP	500	OJ267807	M16	HDG	250
OJ202624	M5	BZP	1000	OJ202686	M16	BZP	250	OJ267814	M20	HDG	100
OJ202631	M6	BZP	1000	OJ202693	M20	BZP	100	OJ267821	M24	HDG	100
OJ202648	M8	BZP	1000	OJ676296	M24	BZP	100	OJ267838	M30	HDG	100
OJ202655	M10	BZP	1000	OJ270357	M10	HDG	500				

Spring Washers

Phosphorous Bronze DIN 7980

Product Codes Begin **Q67798** Product Group **3506**

Article No.	Size	Box Qty.						
HX732770	M3	1000	HX732831	M6	1000	HX732824	M12	250
HX732787	M4	1000	HX732794	M8	500			
HX732800	M5	1000	HX732817	M10	500			

Washers

Serrated Lock Washers

External Serrated DIN 6798A (Fan Disc)

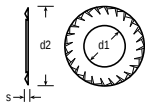

	d1	M3	M4	M5	M6	M8	M10	M12	M16	M20	M24
d2 max.		6	8	10	11	14	18	20.5	26	33	38
s		0.4	0.55	0.6	0.7	0.8	0.9	1.0	1.2	1.4	1.5

Carton

Product Codes Begin **YSFEDS** Product Group **40**

Article No.	Size	Finish	Box Qty.
OJ267241	M3	BZP	2000
OJ267258	M4	BZP	2000
OJ267265	M5	BZP	1000
OJ267272	M6	BZP	1000

OJ267289	M8	BZP	1000
OJ267296	M10	BZP	1000
OJ267302	M12	BZP	1000
OJ267319	M16	BZP	500

OJ267326	M20	BZP	250
OJ267333	M24	BZP	150

Serrated Lock Washers

Internal Serrated DIN 6798J (Fan Disc)

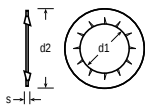

	d1	M3	M4	M5	M6	M8	M10	M12	M16	M20	M24
d2 max.		6	8	10	11	14	18	20.5	26	33	38
s		0.40	0.6	0.6	0.7	0.8	0.9	1	1.2	1.4	1.5

Product Codes Begin **YSFIDS** Product Group **40**

OJ267142	M3	BZP	2000
OJ267159	M4	BZP	2000
OJ267166	M5	BZP	1000
OJ267173	M6	BZP	1000

OJ267180	M8	BZP	1000
OJ267197	M10	BZP	1000
OJ267203	M12	BZP	1000
OJ267210	M16	BZP	500

OJ267227	M20	BZP	250
OJ267234	M24	BZP	150

Toothed Lock Washers

External Toothed DIN 6797A

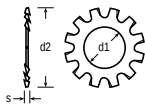

	d1	M3	M4	M5	M6	M8	M10	M12	M16	M20
d2 max.		6	8	10	11	15	18	20.5	26	33
s		0.4	0.5	0.6	0.7	0.8	0.9	1.0	1.2	1.4

Product Codes Begin **YTFEDS** Product Group **40**

OJ677149	M3	BZP	10000
OJ677156	M4	BZP	10000
OJ677163	M5	BZP	10000

OJ677170	M6	BZP	5000
OJ677187	M8	BZP	2500
OJ677194	M10	BZP	2500

OJ677200	M12	BZP	1000
OJ677217	M16	BZP	500
OJ677224	M20	BZP	500



Toothed Lock Washers

Internal Toothed DIN 6797J

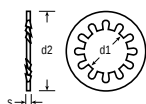

d1	M 3	M 4	M 5	M 6	M 8	M 10	M 12	M 16	M 20
d2 max.	6	8	10	11	15	18	20.5	26	33
s	0.4	0.5	0.6	0.7	0.8	0.9	1.0	1.2	1.4

Product Codes Begin **YTFIDS** Product Group **40**

OJ677231	M3	BZP	10000	OJ677279	M8	BZP	2500	OJ677316	M20	BZP	500
OJ677248	M4	BZP	10000	OJ677286	M10	BZP	2500	OJ677323	M24	BZP	250
OJ677255	M5	BZP	10000	OJ677293	M12	BZP	1000				
OJ677262	M6	BZP	5000	OJ677309	M16	BZP	500				

Square Plate Washers

Square Plate Round Hole



Carton

Product Codes Begin **VP** Product Group **14 & 19**

Article No.	Thickness mm Plate Size ID	Finish	Box Qty.				
OJ366302	M10 × 40 × 40 × 3	BZP	250	OJ366388	M16 × 50 × 50 × 3	BZP	500
OJ366326	M12 × 40 × 40 × 3	BZP	500	OJ235387	M20 × 50 × 50 × 3	BZP	400
OJ235370	M8 × 50 × 50 × 3	BZP	400	OJ235400	M12 × 40 × 40 × 5	Galv	400
OJ366340	M10 × 50 × 50 × 3	BZP	250	OJ235417	M16 × 50 × 50 × 3	Galv	400
OJ366364	M12 × 50 × 50 × 3	BZP	250				

Small Box

OJ032368	M6 × 40 × 40 × 3	BZP	100	OJ032405	M8 × 40 × 40 × 3	HDG	100
OJ032375	M6 × 40 × 40 × 5	BZP	100	OJ032443	M8 × 40 × 40 × 5	HDG	100
OJ235394	M8 × 40 × 40 × 3	BZP	100	OJ032412	M10 × 40 × 40 × 3	HDG	100
OJ032382	M8 × 40 × 40 × 5	BZP	100	OJ032450	M10 × 40 × 40 × 5	HDG	100
OJ235448	M10 × 40 × 40 × 3	BZP	100	OJ032474	M10 × 50 × 50 × 3	HDG	100
OJ235356	M10 × 40 × 40 × 5	BZP	100	OJ032429	M12 × 40 × 40 × 3	HDG	100
OJ060132	M12 × 40 × 40 × 3	BZP	100	OJ032467	M12 × 40 × 40 × 5	HDG	100
OJ235363	M12 × 40 × 40 × 5	BZP	100	OJ032481	M12 × 50 × 50 × 3	HDG	100
OJ426181	M10 × 50 × 50 × 3	BZP	100	OJ126470	M10 × 40 × 40 × 3	SC	100
OJ426204	M12 × 50 × 50 × 3	BZP	100	OJ060149	M10 × 50 × 50 × 3	SC	100
OJ493909	M16 × 50 × 50 × 3	BZP	100	OJ060156	M12 × 50 × 50 × 3	SC	100
OJ032399	M6 × 40 × 40 × 3	HDG	100	OJ060163	M16 × 50 × 50 × 3	SC	100
OJ032436	M6 × 40 × 40 × 5	HDG	100				



Heico Lock Washers

Broad O/D Wedge Lock Washer Delta Pro



Product Codes Begin **WLB** Product Group **42**

Article No.	Size	Box Qty.
OJ473277	M4	200
OJ473284	M5	200
OJ473291	M6	200

OJ473307	M8	200
OJ473314	M10	200
OJ473321	M12	100

OJ473338	M16	100
OJ473345	M20	100



Wedge Locking Washer Delta Pro

Product Codes Begin **WLS** Product Group **42**

OJ409498	M3	200
OJ409504	M4	200
OJ409511	M5	200
OJ409528	M6	200
OJ409535	M8	200

OJ409542	M10	200
OJ409559	M12	200
OJ572772	M14	100
OJ409566	M16	100
OJ409573	M20	100

OJ426396	M24	100
OJ573786	M27	50
OJ426402	M30	50
OJ573793	M36	25



Wedge Locking Washer Stainless Steel

Product Codes Begin **WLS** Product Group **42**

OJ409580	M5	200
OJ409597	M6	200
OJ409603	M8	200

OJ409610	M10	200
OJ409627	M12	200
OJ409634	M16	100

OJ409641	M20	100
HX463551	M24	100



Ring Lock Washer Delta Pro

Product Codes Begin **WLR** Product Group **42**

OJ473352	M5	200
OJ473369	M6	200
OJ473376	M8	200
OJ473383	M10	200

OJ473390	M12	200
OJ473406	M16	100
OJ473413	M20	100



Ring Lock Washer Stainless Steel

Product Codes Begin **WLR** Product Group **42**

OJ473420	M5	200
OJ473437	M6	200
OJ473444	M8	200
OJ473451	M10	200

OJ473468	M12	200
OJ473475	M16	100
OJ473482	M20	100



Wedge Lock Nut Delta Pro

Product Codes Begin **WLN** Product Group **42**

OJ473499	M6	100
OJ473505	M8	100
OJ473512	M10	50
OJ473529	M12	50
OJ473536	M16	25

Teco Timber Connectors

Galvanised Double Sided



Product Codes Begin **9GALVDS** Product Group **5063**

Article No.	Size	ODxID	Box Qty.
TC DS 50	50mm Double Sided M12	CE	100
TC DS 63	63mm Double Sided M12	CE	100
TC DS 76	76mm Double Sided M12	CE	75

Galvanised Single Sided



Product Codes Begin **9GALVSS** Product Group **5063**

TC SS 50	50mm Single Sided M12	CE	100
TC SS 63	63mm Single Sided M12	CE	100

Washers

Self Colour Imperial Table 7 Washers

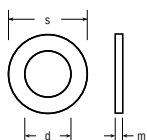

d1	7/8"	1"	1.1/8"	1.1/4"	1.1/2"	1.3/4"	2"
m	8g	7g	7g	6g	6g	5g	5g
s	1.7/8	2.1/8	2.3/8	2.5/8	3.1/8	3.5/8	4.1/8

Product Codes Begin **VS7** Product Group **19**

Article No.	Size
OJ366456	7/8"
OJ366463	1"
OJ366470	1.1/8"
OJ366487	1.1/4"
OJ366494	1.1/2"
OJ366500	1.3/4"
OJ366517	2"

BZP Imperial Table 8 Washers

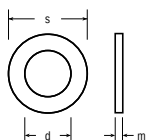

d1	1/4"	3/8"	1/2"	5/8"	3/4"
m	12g	12g	12g	10g	9g
s	3/4	1	1.1/4	1.1/2	1.3/4

Product Codes Begin **VS8** Product Group **19**

OJ366555	1/4"	OJ366647	5/8"
OJ366593	3/8"	OJ366661	3/4"
OJ366623	1/2"		



Self Colour Metric Form E Washers

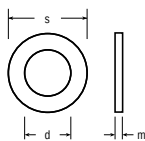

	d1	M12	M16	M20	M24	M30	M36	M42
m		2.50	3.00	3.00	4.00	4.00	5.00	6.00
s		24.00	30.00	37.00	44.00	56.00	66.00	78.00

Product Codes Begin **VSE** Product Group **19**

Article No.	Size	Article No.	Size
OJ366708	M12	OJ366753	M30
OJ366715	M16	OJ366777	M36
OJ366722	M20	OJ366791	M42
OJ366739	M24		

Self Colour Metric Taper Washers



5 Degree

Product Codes Begin **VT5** Product Group **19**

Article No.	Size	Article No.	Size
OJ366814	M12		
OJ366821	M16		
OJ366838	M20		

Self Colour Metric Taper Washers



6.5 Degree

Product Codes Begin **VT6** Product Group **19**

OJ366845	M8	OJ366876	M16
OJ366852	M10	OJ366883	M20
OJ366869	M12	OJ366906	M24

Metric Red Fibre Washers



Product Codes Begin **WFM** Product Group **19**

Article No.	Size	Box Qty.	Article No.	Size	Box Qty.
OJ477145	M2.5	1000	OJ367491	M6	1000
OJ477152	M3	1000	OJ367507	M8	200
OJ367477	M4	1000	OJ367514	M10	200
OJ367484	M5	1000	OJ367521	M12	200



Nylon Washers

Flat Natural DIN 125A

Product Codes Begin **WNA** Product Group **140**

Article No.	Size	Box Qty.
OJ531090	M3	1000
OJ531106	M4	1000
OJ531113	M5	1000
OJ531120	M6	500
OJ531137	M8	500
OJ531144	M10	500
OJ531151	M12	200
OJ531168	M16	100
OJ531175	M20	100
OJ531182	M24	50



Bolt & Nut Cover Caps

Product Codes Begin **NNCB** Product Group **140**

Article No.	Size	Finish	Box Qty.
OJ531205	M5	Blk	100
OJ531229	M6	Blk	100
OJ531243	M8	Blk	100
OJ531267	M10	Blk	100
OJ531281	M12	Blk	50
OJ531304	M16	Blk	50
OJ531199	M5	Wht	100
OJ531212	M6	Wht	100
OJ531236	M8	Wht	100
OJ531250	M10	Wht	100
OJ531274	M12	Wht	50
OJ531298	M16	Wht	50

LEADING BRANDS FROM YOUR NUMBER 1 SUPPLIER

Owlett-Jaton

UNIFIX®



THUNDERBOLT™

VORTEX®

lindapter®



ABRACS
abrasives and accessories



bond it

BLINDBOLT



Scell-it®

MAP
HARDWARE



Ulti-Mate® II

sapphire™
WALL TO WALL QUALITY

TECO
BUILDING PRODUCTS®



ASTROFLAME
MANUFACTURERS OF PASSIVE FIRE STOP PRODUCTS

TIMBERDRIVE

UNION
ASSA ABLOY

Stormguard™

Philidas®

Metolux



DUG
FOOT

Kliplok™

Socket Screws & Wrenches

DIN 912 Socket Capscrews

Grade 12.9 ISO 898-1

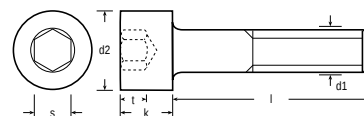

d1	M1.6 PITCH 0.35	M2 PITCH 0.40	M2.5 PITCH 0.45	M3 PITCH 0.50	M4 PITCH 0.70	M5 PITCH 0.80	M6 PITCH 1.00	M8 PITCH 1.25	M10 PITCH 1.50	M12 PITCH 1.75
d2	3	3.8	4.5	5.5	7	8.5	10	13	16	18
k	1.6	2	2.5	3	4	5	6	8	10	12
s	1.5	1.5	2	2.5	3	4	5	6	8	10
t	min.	0.7	1	1.1	1.3	2	2.5	3	5	6

Product Codes Begin **Q12912** Product Group **41**

Article No.	Size	Finish	Article No.	Size	Finish	Article No.	Size	Finish	Article No.	Size	Finish
HX270883	M2.5 × 6	Z&C	HX343235	M6 × 35	Z&C	HX192505	M10 × 45	Z&C	HX381763	M16 × 35	Z&C
HX270906	M2.5 × 12	Z&C	HX343242	M6 × 40	Z&C	HX343457	M10 × 50	Z&C	HX343556	M16 × 40	Z&C
HX342917	M3 × 6	Z&C	HX192376	M6 × 45	Z&C	HX192512	M10 × 55	Z&C	HX343563	M16 × 45	Z&C
HX342924	M3 × 8	Z&C	HX343259	M6 × 50	Z&C	HX343464	M10 × 60	Z&C	HX343570	M16 × 50	Z&C
HX342931	M3 × 10	Z&C	HX343266	M6 × 55	Z&C	HX192529	M10 × 65	Z&C	HX343594	M16 × 60	Z&C
HX342948	M3 × 12	Z&C	HX343273	M6 × 60	Z&C	HX192536	M10 × 70	Z&C	HX192710	M16 × 65	Z&C
HX342955	M3 × 16	Z&C	HX192383	M6 × 65	Z&C	HX192543	M10 × 75	Z&C	HX192727	M16 × 70	Z&C
HX342962	M3 × 20	Z&C	HX192390	M6 × 70	Z&C	HX192550	M10 × 80	Z&C	HX192734	M16 × 80	Z&C
HX342979	M3 × 25	Z&C	HX192406	M6 × 75	Z&C	HX192567	M10 × 90	Z&C	HX192741	M16 × 90	Z&C
HX192338	M4 × 6	Z&C	HX192413	M6 × 80	Z&C	HX192574	M10 × 100	Z&C	HX192758	M16 × 100	Z&C
HX342993	M4 × 8	Z&C	HX192420	M6 × 90	Z&C	HX381527	M10 × 120	Z&C	HX192765	M16 × 120	Z&C
HX343006	M4 × 10	Z&C	HX381381	M6 × 100	Z&C	HX381534	M10 × 130	Z&C	HX381800	M16 × 130	Z&C
HX343013	M4 × 12	Z&C	HX192437	M8 × 10	Z&C	HX381558	M10 × 150	Z&C	HX381817	M16 × 140	Z&C
HX343020	M4 × 16	Z&C	HX343280	M8 × 12	Z&C	IC356037	M10 × 230	Z&C	HX381824	M16 × 150	Z&C
HX381183	M4 × 18	Z&C	HX343297	M8 × 16	Z&C	HX192598	M12 × 20	Z&C	HX381930	M20 × 40	Z&C
HX343037	M4 × 20	Z&C	IC359168	M8 × 16	Z&C	HX343471	M12 × 25	Z&C	HX192796	M20 × 50	Z&C
HX343044	M4 × 25	Z&C	HX343303	M8 × 20	Z&C	HX343488	M12 × 30	Z&C	HX381954	M20 × 55	Z&C
HX343051	M4 × 30	Z&C	HX343310	M8 × 25	Z&C	HX343495	M12 × 35	Z&C	HX192802	M20 × 60	Z&C
HX343068	M4 × 40	Z&C	HX343327	M8 × 30	Z&C	HX343501	M12 × 40	Z&C	HX381961	M20 × 65	Z&C
HX192345	M4 × 50	Z&C	HX343334	M8 × 35	Z&C	HX192604	M12 × 45	Z&C	HX192819	M20 × 70	Z&C
HX381251	M5 × 6	Z&C	HX343341	M8 × 40	Z&C	HX343518	M12 × 50	Z&C	IC346656	M20 × 75	Z&C
HX192352	M5 × 8	Z&C	HX343358	M8 × 45	Z&C	HX192611	M12 × 55	Z&C	HX192826	M20 × 80	Z&C
HX343075	M5 × 10	Z&C	HX343365	M8 × 50	Z&C	HX343525	M12 × 60	Z&C	HX192833	M20 × 90	Z&C
HX343082	M5 × 12	Z&C	HX192444	M8 × 55	Z&C	HX192628	M12 × 65	Z&C	HX381985	M20 × 100	Z&C
HX343099	M5 × 16	Z&C	HX343372	M8 × 60	Z&C	HX192635	M12 × 70	Z&C	HX381992	M20 × 110	Z&C
HX343105	M5 × 20	Z&C	HX192451	M8 × 65	Z&C	HX192642	M12 × 75	Z&C	HX382005	M20 × 120	Z&C
HX343112	M5 × 25	Z&C	HX343389	M8 × 70	Z&C	HX343532	M12 × 80	Z&C	HX382012	M20 × 130	Z&C
HX343129	M5 × 30	Z&C	HX192468	M8 × 75	Z&C	HX192659	M12 × 90	Z&C	IC350097	M24 × 50	Z&C
HX192369	M5 × 35	Z&C	HX343396	M8 × 80	Z&C	HX343549	M12 × 100	Z&C	IC349862	M24 × 55	Z&C
HX343136	M5 × 40	Z&C	HX192475	M8 × 90	Z&C	HX192666	M12 × 110	Z&C	HX382258	M24 × 70	Z&C
HX343143	M5 × 45	Z&C	HX192482	M8 × 100	Z&C	HX381589	M12 × 120	Z&C	HX382265	M24 × 100	Z&C
HX343150	M5 × 50	Z&C	HX381459	M8 × 110	Z&C	HX192673	M12 × 130	Z&C	HX382272	M24 × 110	Z&C
HX381299	M5 × 60	Z&C	HX381466	M8 × 120	Z&C	IC314914	M12 × 140	Z&C	IC333366	M24 × 140	Z&C
HX343167	M6 × 8	Z&C	HX381497	M10 × 12	Z&C	IC354309	M12 × 150	Z&C	HX382289	M24 × 160	Z&C
HX343174	M6 × 10	Z&C	HX343402	M10 × 16	Z&C	IC336572	M12 × 200	Z&C	HX340371	M1.6 × 3	SC
HX343181	M6 × 12	Z&C	HX343419	M10 × 20	Z&C	IC336800	M12 × 220	Z&C	HX381060	M1.6 × 4	SC
HX343198	M6 × 16	Z&C	HX343426	M10 × 25	Z&C	IC314358	M14 × 30	Z&C	HX340388	M1.6 × 6	SC
HX343204	M6 × 20	Z&C	HX343433	M10 × 30	Z&C	IC349954	M14 × 50	Z&C	HX381091	M1.6 × 10	SC
HX343211	M6 × 25	Z&C	HX192499	M10 × 35	Z&C	IC355672	M14 × 100	Z&C	HX973401	M2 × 3	SC
HX343228	M6 × 30	Z&C	HX343440	M10 × 40	Z&C	HX192697	M16 × 30	Z&C	HX340395	M2 × 4	SC



M14	M16	M18	M20	M22	M24	M27	M30	M33	M36
PITCH 2.00	PITCH 2.00	PITCH 2.50	PITCH 2.50	PITCH 2.50	PITCH 3.00	PITCH 3.0	PITCH 3.50	PITCH 3.50	PITCH 4.00
21	24	27	30	33	36	40	45	50	58
14	16	18	20	22	24	27	30	33	36
12	14	14	17	17	19	19	22	24	27
7	8	9	10	11	12	13	15	18	19

Article No.	Size	Finish
HX340401	M2 x 5	SC
HX340418	M2 x 6	SC
HX340425	M2 x 8	SC
HX200309	M2 x 10	SC
HX340449	M2 x 12	SC
HX340463	M2.5 x 5	SC
HX340470	M2.5 x 6	SC
HX165998	M2.5 x 8	SC
HX381107	M2.5 x 10	SC
HX340500	M2.5 x 12	SC
HX381114	M2.5 x 16	SC
HX340524	M3 x 5	SC
HX340531	M3 x 6	SC
HX340548	M3 x 8	SC
HX340555	M3 x 10	SC
HX340562	M3 x 12	SC
HX340579	M3 x 14	SC
HX381138	M3 x 15	SC
HX340586	M3 x 16	SC
HX340593	M3 x 20	SC
HX340609	M3 x 25	SC
HX340616	M3 x 30	SC
HX340623	M3 x 35	SC
HX340630	M3 x 40	SC
HX340661	M4 x 6	SC
HX340678	M4 x 8	SC
HX340685	M4 x 10	SC
HX340708	M4 x 12	SC
HX721828	M4 x 14	SC
HX340722	M4 x 16	SC
HX381176	M4 x 18	SC
HX340739	M4 x 20	SC
HX340753	M4 x 25	SC
HX340760	M4 x 30	SC
HX340777	M4 x 35	SC
HX340784	M4 x 40	SC
HX191812	M4 x 45	SC
HX973425	M4 x 50	SC
HX381213	M4 x 55	SC
HX381237	M4 x 70	SC

HX340821	M5 x 6	SC
HX340838	M5 x 8	SC
HX340845	M5 x 10	SC
HX340852	M5 x 12	SC
HX381268	M5 x 14	SC
HX170688	M5 x 15	SC
HX340876	M5 x 16	SC
HX340883	M5 x 18	SC
HX340890	M5 x 20	SC
HX340906	M5 x 25	SC
HX340913	M5 x 30	SC
HX340920	M5 x 35	SC
HX340937	M5 x 40	SC
HX340944	M5 x 45	SC
HX340951	M5 x 50	SC
HX191829	M5 x 55	SC
HX340968	M5 x 60	SC
HX340975	M5 x 65	SC
HX340982	M5 x 70	SC
HX340999	M5 x 75	SC
HX341002	M5 x 80	SC
HX341019	M5 x 90	SC
HX341026	M5 x 100	SC
HX381312	M5 x 110	SC
HX381329	M5 x 120	SC
HX341033	M6 x 8	SC
HX341040	M6 x 10	SC
HX341057	M6 x 12	SC
HX341064	M6 x 14	SC
HX341071	M6 x 15	SC
HX341088	M6 x 16	SC
HX341095	M6 x 18	SC
HX341101	M6 x 20	SC
HX341118	M6 x 25	SC
HX341125	M6 x 30	SC
HX341132	M6 x 35	SC
HX341149	M6 x 40	SC
HX341156	M6 x 45	SC
HX341163	M6 x 50	SC
HX341170	M6 x 55	SC

HX341187	M6 x 60	SC
HX341194	M6 x 65	SC
HX341200	M6 x 70	SC
HX341217	M6 x 75	SC
HX341224	M6 x 80	SC
HX381374	M6 x 85	SC
HX341248	M6 x 90	SC
HX341255	M6 x 100	SC
HX341262	M6 x 110	SC
HX341279	M6 x 120	SC
HX341286	M6 x 130	SC
HX381404	M6 x 140	SC
HX341293	M6 x 150	SC
HX381411	M8 x 8	SC
HX341309	M8 x 10	SC
HX341316	M8 x 12	SC
HX341330	M8 x 15	SC
HX341347	M8 x 16	SC
HX381435	M8 x 18	SC
HX341354	M8 x 20	SC
HX381442	M8 x 22	SC
HX341361	M8 x 25	SC
HX341378	M8 x 30	SC
HX341385	M8 x 35	SC
HX341392	M8 x 40	SC
HX341408	M8 x 45	SC
HX341415	M8 x 50	SC
HX341422	M8 x 55	SC
HX341439	M8 x 60	SC
HX973432	M8 x 65	SC
HX341446	M8 x 70	SC
HX341453	M8 x 75	SC
HX341460	M8 x 80	SC
HX341477	M8 x 90	SC
HX341484	M8 x 100	SC
HX341491	M8 x 110	SC
HX341507	M8 x 120	SC
HX341514	M8 x 130	SC
HX341521	M8 x 140	SC
HX341538	M8 x 150	SC

HX341545	M8 x 160	SC
HX341552	M8 x 180	SC
HX381480	M8 x 200	SC
HX341576	M10 x 10	SC
HX341583	M10 x 12	SC
HX341590	M10 x 16	SC
HX341606	M10 x 20	SC
HX341613	M10 x 25	SC
HX341620	M10 x 30	SC
HX341637	M10 x 35	SC
HX341644	M10 x 40	SC
HX341651	M10 x 45	SC
HX341668	M10 x 50	SC
HX341675	M10 x 55	SC
HX341682	M10 x 60	SC
HX341699	M10 x 65	SC
HX341705	M10 x 70	SC
HX341712	M10 x 75	SC
HX341729	M10 x 80	SC
HX341736	M10 x 90	SC
HX341743	M10 x 100	SC
HX341750	M10 x 110	SC
HX341767	M10 x 120	SC
HX341774	M10 x 130	SC
HX341781	M10 x 140	SC
HX341798	M10 x 150	SC
HX341804	M10 x 160	SC
HX381565	M10 x 170	SC
HX341811	M10 x 180	SC
HX341828	M10 x 200	SC
IC316574	M10 x 240	SC
HX341835	M12 x 16	SC
HX341842	M12 x 20	SC
HX341859	M12 x 25	SC
HX341866	M12 x 30	SC
HX341873	M12 x 35	SC
HX341880	M12 x 40	SC
HX341897	M12 x 45	SC
HX341903	M12 x 50	SC
HX341910	M12 x 55	SC

Socket Screws & Wrenches

DIN 912 Socket Capscrews

Grade 12.9 ISO 898-1

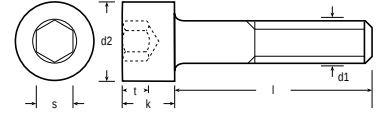

Product Codes Begin **Q12912** Product Group **41**

Article No.	Size	Finish									
HX341927	M12 × 60	SC	HX342221	M16 × 45	SC	HX342504	M20 × 70	SC	HX342771	M24 × 180	SC
HX341934	M12 × 65	SC	HX342238	M16 × 50	SC	HX191997	M20 × 75	SC	HX382302	M24 × 190	SC
HX341941	M12 × 70	SC	HX342245	M16 × 55	SC	HX342511	M20 × 80	SC	HX342788	M24 × 200	SC
HX341958	M12 × 75	SC	HX342252	M16 × 60	SC	HX342528	M20 × 90	SC	HX342795	M24 × 220	SC
HX341965	M12 × 80	SC	HX342269	M16 × 65	SC	HX342535	M20 × 100	SC	HX382319	M24 × 240	SC
HX341972	M12 × 90	SC	HX342276	M16 × 70	SC	HX342542	M20 × 110	SC	HX382333	M24 × 280	SC
HX341989	M12 × 100	SC	HX342283	M16 × 75	SC	HX342559	M20 × 120	SC	HX382340	M24 × 300	SC
HX341996	M12 × 110	SC	HX342290	M16 × 80	SC	HX342566	M20 × 130	SC	HX382456	M27 × 150	SC
HX342009	M12 × 120	SC	HX342306	M16 × 90	SC	HX342573	M20 × 140	SC	HX382500	M30 × 60	SC
HX342016	M12 × 130	SC	HX342313	M16 × 100	SC	HX342580	M20 × 150	SC	HX382531	M30 × 75	SC
HX342023	M12 × 140	SC	HX342320	M16 × 110	SC	HX342597	M20 × 160	SC	HX342801	M30 × 80	SC
HX342030	M12 × 150	SC	HX342337	M16 × 120	SC	HX192000	M20 × 170	SC	HX342818	M30 × 90	SC
HX342047	M12 × 160	SC	HX342344	M16 × 130	SC	HX342603	M20 × 180	SC	HX342825	M30 × 100	SC
HX191843	M12 × 170	SC	HX342351	M16 × 140	SC	HX382043	M20 × 190	SC	HX382548	M30 × 110	SC
HX342054	M12 × 180	SC	HX342368	M16 × 150	SC	HX342610	M20 × 200	SC	HX342832	M30 × 120	SC
HX381619	M12 × 190	SC	HX342375	M16 × 160	SC	HX342627	M20 × 220	SC	HX192161	M30 × 130	SC
HX342061	M12 × 200	SC	HX191881	M16 × 170	SC	HX382050	M20 × 240	SC	HX342849	M30 × 140	SC
HX381626	M12 × 220	SC	HX342382	M16 × 180	SC	HX382067	M20 × 260	SC	HX342856	M30 × 150	SC
HX381633	M12 × 240	SC	HX342399	M16 × 200	SC	IC355559	M20 × 300	SC	HX382555	M30 × 160	SC
HX381640	M12 × 250	SC	IC362939	M16 × 210	SC	HX382111	M22 × 70	SC	HX342870	M30 × 180	SC
HX381657	M12 × 260	SC	HX342405	M16 × 220	SC	HX382135	M22 × 80	SC	HX342887	M30 × 200	SC
HX381664	M12 × 280	SC	HX342412	M16 × 240	SC	HX382142	M22 × 90	SC	HX382586	M30 × 260	SC
HX381671	M12 × 300	SC	HX342429	M16 × 260	SC	HX382159	M22 × 100	SC	HX382715	M36 × 80	SC
IC357676	M14 × 20	SC	HX342436	M16 × 280	SC	HX382166	M22 × 110	SC	HX721835	M36 × 110	SC
HX381695	M14 × 25	SC	HX381831	M18 × 35	SC	HX382180	M22 × 130	SC	HX382753	M36 × 120	SC
HX342078	M14 × 30	SC	HX381848	M18 × 40	SC	HX382210	M22 × 180	SC	HX382777	M36 × 140	SC
HX342085	M14 × 35	SC	HX191898	M18 × 50	SC	HX382227	M22 × 200	SC	HX382791	M36 × 160	SC
HX342092	M14 × 40	SC	HX381855	M18 × 55	SC	HX342641	M24 × 40	SC	HX382838	M36 × 260	SC
HX342108	M14 × 45	SC	HX191911	M18 × 60	SC	HX382234	M24 × 45	SC	HX192321	M36 × 300	SC
HX342115	M14 × 50	SC	HX191935	M18 × 80	SC	HX342658	M24 × 50	SC			
HX342139	M14 × 60	SC	HX191942	M18 × 90	SC	HX342665	M24 × 55	SC			
HX381701	M14 × 65	SC	HX191959	M18 × 100	SC	HX342672	M24 × 60	SC			
HX381718	M14 × 70	SC	HX381886	M18 × 110	SC	HX382241	M24 × 65	SC			
HX342153	M14 × 80	SC	HX381893	M18 × 120	SC	HX342689	M24 × 70	SC			
HX342160	M14 × 90	SC	HX381909	M18 × 130	SC	HX192062	M24 × 75	SC			
HX342177	M14 × 100	SC	HX381916	M18 × 150	SC	HX342696	M24 × 80	SC			
HX191867	M14 × 110	SC	HX381923	M18 × 200	SC	HX342702	M24 × 90	SC			
HX381725	M14 × 120	SC	HX191966	M20 × 30	SC	HX342719	M24 × 100	SC			
HX191874	M14 × 130	SC	HX191973	M20 × 35	SC	HX342726	M24 × 110	SC			
HX381732	M14 × 200	SC	HX342450	M20 × 40	SC	HX342733	M24 × 120	SC			
HX381749	M16 × 20	SC	HX342467	M20 × 45	SC	HX192079	M24 × 130	SC			
HX342184	M16 × 25	SC	HX342474	M20 × 50	SC	HX342740	M24 × 140	SC			
HX342191	M16 × 30	SC	HX342481	M20 × 55	SC	HX342757	M24 × 150	SC			
HX342207	M16 × 35	SC	HX342498	M20 × 60	SC	HX342764	M24 × 160	SC			
HX342214	M16 × 40	SC	HX191980	M20 × 65	SC	HX382296	M24 × 170	SC			



DIN 912 Socket Capscrews

Grade 12.9 ISO 898-1 Fully Threaded

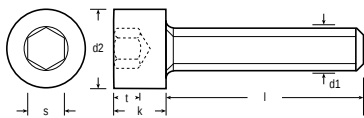

d1	M5 PITCH 0.80	M6 PITCH 1.00	M8 PITCH 1.25	M10 PITCH 1.50	M12 PITCH 1.75	M16 PITCH 2.00
d2	8.5	10	13	16	18	24
k	5	6	8	10	12	16
s	4	5	6	8	10	14
t min.	2.5	3	4	5	6	8

Product Codes Begin [Q12912T](#) Product Group [41](#)

Article No.	Size	Finish
HX383262	M6 × 45	SC
HX383491	M10 × 80	SC
HX383620	M16 × 100	SC

DIN 912 Socket Capscrews

Grade 12.9 ISO 898-1 Fine Pitch

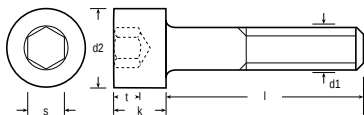

d1	M10 PITCH 1.50	M12 PITCH 1.75
d2	16	18
k	10	12
s	8	10
t min.	5	6

Product Codes Begin [Q12912F](#) Product Group [41](#)

Article No.	Size	Pitch	Finish
HX382890	M10 × 30	(1.25P)	SC
HX382937	M10 × 50	(1.25P)	SC
HX383002	M12 × 50	(1.50P)	SC
HX383064	M12 × 100	(1.50P)	SC

> Socket Screws & Wrenches

ANSI B18.3 UNC Socket Capscrews

1936 Series

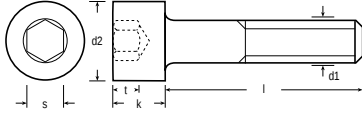

	No. 10 UNC	No. 10.24 UNC	1/4 UNC	5/16 UNC	3/8 UNC	1/2 UNC	5/8 UNC	3/4 UNC	7/8 UNC
d1									
d2	0.310	0.310	0.370	0.430	0.555	0.745	0.865	0.990	1.115
k	0.190	0.190	0.250	0.310	0.370	0.495	0.620	0.745	0.870
s nom.	5/32	5/32	3/16	5/32	3/16	3/8	1/2	9/16	9/16
t min.	0.090	0.090	0.120	0.151	0.182	0.240	0.307	0.370	0.432

Product Codes Begin **Q1219361C** Product Group **41**

Article No.	Size	Finish					
HX338583	10 UNC × 1/2	SC	HX338798	5/16 UNC × 2.1/2	SC	HX339016	1/2 UNC × 2
HX338606	10 UNC × 3/4	SC	HX455754	3/8 UNC × 3/4	SC	HX455808	1/2 UNC × 2.1/4
HX456072	10.24 UNC × 1.1/4	SC	HX272498	3/8 UNC × 1	SC	HX339023	1/2 UNC × 2.1/2
HX721569	1/4 UNC × 3/8	SC	HX338859	3/8 UNC × 1.1/4	SC	HX339030	1/2 UNC × 3
HX338613	1/4 UNC × 1/2	SC	HX338866	3/8 UNC × 1.1/2	SC	HX339047	1/2 UNC × 3.1/2
HX266183	1/4 UNC × 5/8	SC	HX338873	3/8 UNC × 1.3/4	SC	HX455839	1/2 UNC × 5
HX338637	1/4 UNC × 3/4	SC	HX267760	3/8 UNC × 2	SC	HX455846	1/2 UNC × 6
HX338644	1/4 UNC × 7/8	SC	HX338903	3/8 UNC × 2.1/2	SC	HX455853	5/8 UNC × 1
HX266190	1/4 UNC × 1	SC	HX455778	3/8 UNC × 2.3/4	SC	HX455860	5/8 UNC × 2.1/4
HX338668	1/4 UNC × 1.1/4	SC	HX338910	3/8 UNC × 3	SC	HX455884	5/8 UNC × 3
HX338675	1/4 UNC × 1.1/2	SC	HX338927	3/8 UNC × 3.1/2	SC	HX455891	5/8 UNC × 4
HX338682	1/4 UNC × 1.3/4	SC	HX338934	3/8 UNC × 4	SC	HX455938	3/4 UNC × 2.1/4
HX338699	1/4 UNC × 2	SC	HX338972	1/2 UNC × 1	SC	HX455945	3/4 UNC × 2.1/2
HX455730	1/4 UNC × 2.3/4	SC	HX338989	1/2 UNC × 1.1/4	SC	HX455952	3/4 UNC × 3
HX338705	5/16 UNC × 1/2	SC	HX455785	1/2 UNC × 1.1/2	SC	HX456010	7/8 UNC × 2.1/2
HX338767	5/16 UNC × 1.3/4	SC	HX339009	1/2 UNC × 1.3/4	SC		



ANSI B18.3 UNC Socket Capscrews

1960 Series

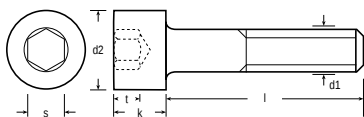

	No. 4.40 UNC	No. 6.32 UNC	No. 8.32 UNC	5/16 UNC	7/16 UNC	5/8 UNC	3/4 UNC	1 UNC
d1								
d2	0.183	0.226	0.270	0.469	0.656	0.930	1.115	1.490
k	0.051	0.138	0.164	0.312	0.438	0.620	0.745	0.995
s	nom. 3/32	7/64	9/64	1/4	3/8	1/2	5/8	3/4
t	min. 0.051	0.064	0.077	0.151	0.213	0.307	0.370	0.495

Product Codes Begin **Q1219601C** Product Group **41**

Article No.	Size	Finish						
HX456249	5/16 UNC × 3/4	SC	HX456348	5/8 UNC × 2	SC	HX721767	6.32 UNC × 3/8	SC
HX338736	5/16 UNC × 1	SC	HX721743	4.40 UNC × 1/8	SC	HX456461	6.32 UNC × 1/2	SC
HX456324	5/8 UNC × 1.1/2	SC	HX456454	4.40 UNC × 3/8	SC	HX456485	8.32 UNC × 3/4	SC

ANSI B18.3 UNF Socket Capscrews

1936 Series

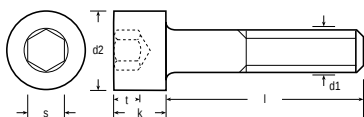

	No. 10 UNF	No. 10.32 UNF	1/4 UNF	3/8 UNF	1/2 UNF
d1					
d2	0.310	0.310	0.370	0.555	0.745
k	0.190	0.190	0.250	0.370	0.495
s	nom. 5/32	5/32	3/16	3/16	3/8
t	min. 0.090	0.090	0.120	0.120	0.240

Product Codes Begin **Q1219361N** Product Group **41**

HX339177	10 UNF × 1/2	SC	HX721620	1/4 UNF × 2	SC	HX339498	1/2 UNF × 1.1/4	SC
HX339184	10 UNF × 5/8	SC	HX339382	3/8 UNF × 3/4	SC	HX456119	1/2 UNF × 1.1/2	SC
HX456171	10.32 UNF × 3/4	SC	HX339405	3/8 UNF × 1	SC	HX339528	1/2 UNF × 2	SC
HX339221	1/4 UNF × 1/2	SC	HX339412	3/8 UNF × 1.1/4	SC	HX456126	1/2 UNF × 2.1/4	SC
HX721613	1/4 UNF × 3/4	SC	HX339429	3/8 UNF × 1.1/2	SC	HX456133	1/2 UNF × 2.1/2	SC
HX339252	1/4 UNF × 7/8	SC	HX339436	3/8 UNF × 1.3/4	SC	HX456140	1/2 UNF × 3	SC
HX339269	1/4 UNF × 1	SC	HX721637	3/8 UNF × 2	SC			
HX339276	1/4 UNF × 1.1/4	SC	HX339450	3/8 UNF × 2.1/2	SC			
HX339283	1/4 UNF × 1.1/2	SC	HX456102	1/2 UNF × 1	SC			

> Socket Screws & Wrenches

BS2470 BSW Socket Capscrews

1936 Series

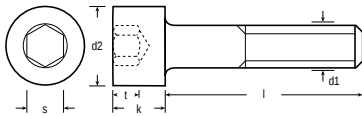

d1	3/16 BSW	1/4 BSW	5/16 BSW	3/8 BSW	1/2 BSW	5/8 BSW	3/4 BSW
d2	0.310	0.370	0.430	0.555	0.745	0.865	0.990
k	0.185	0.250	0.310	0.370	0.495	0.620	0.745
s	nom.	5/32	3/16	5/32	3/8	1/2	9/16
t	min.	0.090	0.120	0.151	0.182	0.240	0.370

Product Codes Begin **Q1219361W** Product Group **41**

Article No.	Size	Finish	Article No.	Size	Finish	Article No.	Size	Finish
HX344492	3/16 BSW × 1	SC	HX344683	5/16 BSW × 2.1/2	SC	HX344843	1/2 BSW × 1.1/2	SC
HX721644	1/4 BSW × 1/2	SC	HX344706	3/8 BSW × 1/2	SC	HX456201	1/2 BSW × 2	SC
HX344539	1/4 BSW × 5/8	SC	HX344713	3/8 BSW × 3/4	SC	HX344874	1/2 BSW × 2.1/2	SC
HX721651	1/4 BSW × 1	SC	HX344720	3/8 BSW × 1	SC	HX344881	1/2 BSW × 3	SC
HX344560	1/4 BSW × 1.1/4	SC	HX344737	3/8 BSW × 1.1/4	SC	HX344904	1/2 BSW × 4	SC
HX344591	1/4 BSW × 2	SC	HX344744	3/8 BSW × 1.1/2	SC	HX344928	5/8 BSW × 2	SC
HX344621	5/16 BSW × 1/2	SC	HX721699	3/8 BSW × 2	SC	HX344942	5/8 BSW × 3	SC
HX721668	5/16 BSW × 3/4	SC	HX344775	3/8 BSW × 2.1/2	SC	HX344959	5/8 BSW × 3.1/2	SC
HX344645	5/16 BSW × 1	SC	HX344782	3/8 BSW × 3	SC	HX344980	3/4 BSW × 1.1/2	SC
HX721675	5/16 BSW × 1.1/2	SC	HX456195	1/2 BSW × 1	SC			
HX344676	5/16 BSW × 2	SC	HX721705	1/2 BSW × 1.1/4	SC			

DIN 7984 Low Head Socket Capscrews

Grade 10.9

Product Codes Begin **Q10798** Product Group **41**

Article No.	Size	Finish	Article No.	Size	Finish
HX451886	M4 × 20	SC	HX451954	M10 × 20	SC
HX721392	M4 × 30	SC	HX451961	M10 × 25	SC
HX337920	M6 × 12	SC	HX451978	M10 × 40	SC
HX337937	M6 × 16	SC	HX451985	M12 × 20	SC
HX337944	M6 × 20	SC	HX451992	M12 × 25	SC
HX337951	M6 × 25	SC			
HX451909	M6 × 45	SC			
HX337975	M8 × 16	SC			
HX337982	M8 × 20	SC			
HX721408	M8 × 25	SC			
HX338002	M8 × 30	SC			



Made in USA
SINCE 1929



- Socket Head Cap Screws
- Socket Button Head Screws
- Socket Countersunk (Flat Head) Screws
- Socket Low Head Cap Screws
- Socket Set Screws
- Socket Shoulder Screws
- Socket Pressure Plugs

**Holo-Krome UK range guide is available -
contact us today to receive your copy**



> Socket Screws & Wrenches

DIN 7991 Socket Csk Screws

Grade 10.9 ISO 898-1

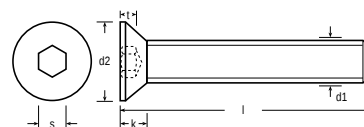

d1	M3	M4	M5	M6	M8	M10	M12	M16	M20	M24	M36
d2	6	8	10	12	16	20	24	30	36	38	57
k max.	1.7	2.3	2.8	3.3	4.4	5.5	6.5	7.5	8.5	14.22	23
s	2	2.5	3	4	5	6	8	10	12	14	19
t	1.2	1.8	2.3	2.5	3.5	4.4	4.6	5.3	5.9	8.25	12

Product Codes Begin **Q107991** Product Group **41**

Article No.	Size	Finish	Article No.	Size	Finish	Article No.	Size	Finish	Article No.	Size	Finish
HX721422	M3 × 6	Z&C	HX336633	M8 × 35	Z&C	HX336930	M16 × 45	Z&C	HX335308	M3 × 6	SC
HX336305	M3 × 8	Z&C	HX336640	M8 × 40	Z&C	HX336947	M16 × 50	Z&C	HX335315	M3 × 8	SC
HX336312	M3 × 10	Z&C	HX336657	M8 × 45	Z&C	HX191683	M16 × 55	Z&C	HX335322	M3 × 10	SC
HX336329	M3 × 12	Z&C	HX336664	M8 × 50	Z&C	HX336954	M16 × 60	Z&C	HX335339	M3 × 12	SC
HX379579	M3 × 16	Z&C	HX336671	M8 × 60	Z&C	HX191690	M16 × 70	Z&C	HX157931	M3 × 16	SC
HX721439	M3 × 20	Z&C	HX336688	M8 × 70	Z&C	HX191706	M16 × 75	Z&C	HX335346	M3 × 20	SC
HX336336	M4 × 8	Z&C	HX191645	M8 × 80	Z&C	HX191713	M16 × 80	Z&C	HX335353	M3 × 25	SC
HX336343	M4 × 10	Z&C	HX379838	M8 × 90	Z&C	HX191720	M16 × 90	Z&C	HX335360	M3 × 30	SC
HX336350	M4 × 12	Z&C	HX379845	M8 × 100	Z&C	HX191737	M16 × 100	Z&C	HX335377	M4 × 8	SC
HX336367	M4 × 16	Z&C	HX336695	M10 × 16	Z&C	HX336961	M20 × 40	Z&C	HX335384	M4 × 10	SC
HX336374	M4 × 20	Z&C	HX336701	M10 × 20	Z&C	HX336978	M20 × 45	Z&C	HX335391	M4 × 12	SC
HX336381	M4 × 25	Z&C	HX336718	M10 × 25	Z&C	HX336985	M20 × 50	Z&C	HX335407	M4 × 15	SC
HX336398	M4 × 30	Z&C	HX336725	M10 × 30	Z&C	HX191751	M20 × 55	Z&C	HX335414	M4 × 16	SC
HX336404	M5 × 10	Z&C	HX336732	M10 × 35	Z&C	HX336992	M20 × 60	Z&C	HX335421	M4 × 20	SC
HX336411	M5 × 12	Z&C	HX336749	M10 × 40	Z&C	HX191768	M20 × 65	Z&C	HX335438	M4 × 25	SC
HX336428	M5 × 16	Z&C	HX336756	M10 × 45	Z&C	HX380582	M20 × 70	Z&C	HX335445	M4 × 30	SC
HX336435	M5 × 20	Z&C	HX336763	M10 × 50	Z&C	HX191782	M20 × 75	Z&C	HX335452	M4 × 35	SC
HX336442	M5 × 25	Z&C	HX379869	M10 × 55	Z&C	HX191799	M20 × 80	Z&C	HX335469	M4 × 40	SC
HX336459	M5 × 30	Z&C	HX336770	M10 × 60	Z&C	HX191805	M20 × 90	Z&C	HX335476	M4 × 50	SC
HX379661	M5 × 35	Z&C	HX336787	M10 × 70	Z&C	HX380636	M20 × 100	Z&C	HX335483	M5 × 8	SC
HX336466	M5 × 40	Z&C	HX191652	M10 × 75	Z&C	HX380872	M24 × 70	Z&C	HX335490	M5 × 10	SC
HX379692	M5 × 50	Z&C	HX336794	M10 × 80	Z&C	HX380902	M24 × 80	Z&C	HX335506	M5 × 12	SC
HX336473	M6 × 10	Z&C	HX379890	M10 × 90	Z&C	HX380926	M24 × 90	Z&C	HX335513	M5 × 16	SC
HX336480	M6 × 12	Z&C	HX379906	M10 × 100	Z&C	HX380940	M24 × 100	Z&C	HX335520	M5 × 20	SC
HX336497	M6 × 16	Z&C	HX336817	M12 × 25	Z&C	HX379920	M12 × 30	HDG	HX335537	M5 × 25	SC
HX336503	M6 × 20	Z&C	HX336824	M12 × 30	Z&C	HX379937	M12 × 35	HDG	HX335544	M5 × 30	SC
HX336510	M6 × 25	Z&C	HX336831	M12 × 35	Z&C	HX379944	M12 × 40	HDG	HX335551	M5 × 35	SC
HX336527	M6 × 30	Z&C	HX336848	M12 × 40	Z&C	HX379968	M12 × 50	HDG	HX335568	M5 × 40	SC
HX336534	M6 × 35	Z&C	HX336855	M12 × 45	Z&C	HX380001	M12 × 60	HDG	HX379678	M5 × 45	SC
HX336541	M6 × 40	Z&C	HX336862	M12 × 50	Z&C	HX380261	M16 × 35	HDG	HX335575	M5 × 50	SC
HX191638	M6 × 45	Z&C	HX336879	M12 × 60	Z&C	HX380278	M16 × 40	HDG	HX379715	M5 × 60	SC
HX336558	M6 × 50	Z&C	HX380025	M12 × 65	Z&C	HX380285	M16 × 45	HDG	HX335582	M6 × 8	SC
HX336565	M6 × 60	Z&C	HX336886	M12 × 70	Z&C	HX380292	M16 × 50	HDG	HX335599	M6 × 10	SC
HX379777	M6 × 65	Z&C	HX191669	M12 × 75	Z&C	HX380315	M16 × 60	HDG	HX335605	M6 × 12	SC
HX379791	M6 × 75	Z&C	HX336893	M12 × 80	Z&C	HX380353	M16 × 70	HDG	HX379739	M6 × 15	SC
HX336589	M8 × 12	Z&C	HX191676	M12 × 90	Z&C	HX380520	M20 × 50	HDG	HX335612	M6 × 16	SC
HX336596	M8 × 16	Z&C	HX380087	M12 × 100	Z&C	HX380544	M20 × 55	HDG	HX379746	M6 × 18	SC
HX336602	M8 × 20	Z&C	HX336909	M16 × 30	Z&C	HX380551	M20 × 60	HDG	HX335629	M6 × 20	SC
HX336619	M8 × 25	Z&C	HX336916	M16 × 35	Z&C	HX380599	M20 × 70	HDG	HX335636	M6 × 25	SC
HX336626	M8 × 30	Z&C	HX336923	M16 × 40	Z&C	HX379548	M3 × 5	SC	HX335643	M6 × 30	SC



HX335650	M6 × 35	SC	HX335971	M10 × 80	SC	HX336206	M16 × 90	SC
HX335667	M6 × 40	SC	HX335988	M10 × 90	SC	HX336213	M16 × 100	SC
HX335674	M6 × 50	SC	HX335995	M10 × 100	SC	HX380407	M16 × 110	SC
HX379753	M6 × 55	SC	HX336008	M12 × 20	SC	HX336220	M16 × 120	SC
HX335681	M6 × 60	SC	HX336015	M12 × 25	SC	HX380438	M16 × 130	SC
HX335698	M6 × 70	SC	HX336022	M12 × 30	SC	HX380445	M16 × 140	SC
HX379784	M6 × 75	SC	HX336039	M12 × 35	SC	HX380469	M16 × 160	SC
HX335704	M6 × 80	SC	HX336046	M12 × 40	SC	HX336244	M20 × 40	SC
HX379807	M6 × 90	SC	HX191423	M12 × 45	SC	HX380506	M20 × 45	SC
HX335711	M8 × 10	SC	HX336053	M12 × 50	SC	HX336251	M20 × 50	SC
HX335728	M8 × 12	SC	HX379975	M12 × 55	SC	HX380537	M20 × 55	SC
HX335735	M8 × 16	SC	HX336060	M12 × 60	SC	HX191522	M20 × 60	SC
HX335742	M8 × 20	SC	HX336077	M12 × 70	SC	HX380568	M20 × 65	SC
HX335759	M8 × 25	SC	HX191447	M12 × 75	SC	HX191546	M20 × 70	SC
HX335766	M8 × 30	SC	HX336084	M12 × 80	SC	HX191553	M20 × 75	SC
HX335773	M8 × 35	SC	HX336091	M12 × 90	SC	HX191560	M20 × 80	SC
HX335780	M8 × 40	SC	HX336107	M12 × 100	SC	HX191577	M20 × 90	SC
HX335797	M8 × 45	SC	HX380100	M12 × 110	SC	HX191584	M20 × 100	SC
HX335803	M8 × 50	SC	HX380117	M12 × 120	SC	HX380650	M20 × 110	SC
HX335810	M8 × 55	SC	HX380124	M12 × 130	SC	HX191607	M20 × 120	SC
HX335827	M8 × 60	SC	HX380131	M12 × 140	SC	HX380735	M20 × 140	SC
HX191393	M8 × 65	SC	HX380155	M14 × 30	SC	HX380803	M20 × 180	SC
HX335834	M8 × 70	SC	HX380179	M14 × 40	SC	HX380827	M24 × 50	SC
HX379821	M8 × 75	SC	HX380193	M14 × 50	SC	HX380841	M24 × 60	SC
HX335841	M8 × 80	SC	HX380209	M14 × 60	SC	HX380865	M24 × 70	SC
HX191409	M8 × 90	SC	HX380216	M14 × 70	SC	HX380896	M24 × 80	SC
HX191416	M8 × 100	SC	HX380223	M14 × 90	SC	HX380919	M24 × 90	SC
HX335865	M10 × 16	SC	HX380230	M14 × 100	SC	HX380933	M24 × 100	SC
HX335872	M10 × 20	SC	HX380247	M16 × 25	SC	HX381008	M24 × 140	SC
HX335889	M10 × 25	SC	HX336114	M16 × 30	SC	HX381015	M24 × 150	SC
HX335896	M10 × 30	SC	HX336121	M16 × 35	SC			
HX335902	M10 × 35	SC	HX336138	M16 × 40	SC			
HX335919	M10 × 40	SC	HX336145	M16 × 45	SC			
HX335926	M10 × 45	SC	HX336152	M16 × 50	SC			
HX335933	M10 × 50	SC	HX336169	M16 × 55	SC			
HX335940	M10 × 55	SC	HX336176	M16 × 60	SC			
HX335957	M10 × 60	SC	HX380322	M16 × 65	SC			
HX379876	M10 × 65	SC	HX336183	M16 × 70	SC			
HX335964	M10 × 70	SC	HX191478	M16 × 75	SC			
HX379883	M10 × 75	SC	HX336190	M16 × 80	SC			

UNC Socket CSK Screws

ANSI B18:3

Product Codes Begin **Q10247** Product Group **41**

HX450155	3/8 UNC × 1.1/2	SC	HX450186	1/2 UNC × 1 1/2	SC
----------	-----------------	----	----------	-----------------	----

UNC Socket CSK Screws

BS2470

Product Codes Begin **Q10247** Product Group **41**

HX721323	1/4 UNC × 1/2	SC	HX721330	1/4 UNC × 1.1/4	SC	HX450179	1/2 UNC × 1.1/4	SC
HX450087	1/4 UNC × 5/8	SC	HX450117	5/6 UNC × 1	SC	HX450186	1/2 UNC × 1.1/2	SC
HX450094	1/4 UNC × 3/4	SC	HX450131	3/8 UNC × 3/4	SC	HX450209	5/8 UNC × 1.1/2	SC
HX450100	1/4 UNC × 1	SC	HX450162	1/2 UNC × 1	SC			

> Socket Screws & Wrenches

DIN 913 Socket Setscrews Flat Point Grade 14.9

45 H

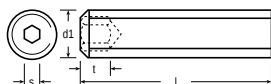

	d1	M3	M4	M5	M6	M8	M10	M12	M16
s		1.5	2.0	2.5	3.0	5.0	6.0	8.0	8.0
t	min.	2.0	2.5	3.0	3.5	4.0	5.0	6.0	10.0

Product Codes Begin **Q14913** Product Group **41**

Article No.	Size	Finish									
HX383811	M3 × 4	SC	HX383910	M4 × 8	SC	HX384054	M6 × 6	SC	HX384160	M8 × 10	SC
HX722054	M3 × 5	SC	HX383927	M4 × 10	SC	HX384061	M6 × 8	SC	HX384177	M8 × 12	SC
HX722061	M3 × 8	SC	HX383934	M4 × 12	SC	HX384078	M6 × 10	SC	HX384184	M8 × 16	SC
HX383859	M3 × 10	SC	HX383941	M4 × 16	SC	HX384085	M6 × 12	SC	HX384207	M8 × 25	SC
HX383866	M3 × 12	SC	HX383965	M5 × 5	SC	HX722078	M6 × 16	SC	HX384238	M8 × 40	SC
HX383873	M3 × 16	SC	HX383989	M5 × 8	SC	HX384108	M6 × 20	SC	HX384245	M10 × 10	SC
IC355832	M4 × 3	SC	HX383996	M5 × 10	SC	HX384115	M6 × 25	SC	HX384276	M10 × 20	SC
HX383880	M4 × 4	SC	HX384009	M5 × 12	SC	HX384122	M6 × 30	SC	HX384283	M10 × 25	SC
HX383897	M4 × 5	SC	HX384016	M5 × 16	SC	HX384146	M6 × 40	SC	HX384344	M12 × 16	SC
HX383903	M4 × 6	SC	HX384030	M5 × 25	SC	HX384153	M8 × 8	SC	HX384405	M12 × 50	SC

DIN 914 Socket Setscrews Cone Point Grade 14.9

45 H

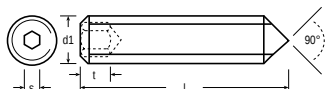

	d1	M3	M4	M5	M6	M8	M10	M12
s		1.5	2.0	2.5	3.0	5.0	6.0	8.0
t	min.	2.0	2.5	3.0	3.5	4.0	5.0	6.0

Product Codes Begin **Q14914** Product Group **41**

HX384443	M3 × 3	SC	HX384559	M4 × 10	SC	HX384665	M6 × 6	SC	HX384771	M8 × 16	SC
HX384450	M3 × 4	SC	HX384573	M4 × 16	SC	HX384672	M6 × 8	SC	HX384801	M8 × 30	SC
HX384467	M3 × 5	SC	HX563749	M4 × 20	SC	HX384689	M6 × 10	SC	HX384832	M10 × 10	SC
HX384474	M3 × 6	SC	HX384597	M5 × 6	SC	HX384696	M6 × 12	SC	HX384856	M10 × 16	SC
HX722115	M3 × 10	SC	HX384603	M5 × 8	SC	HX384702	M6 × 16	SC	HX384863	M10 × 20	SC
HX384504	M3 × 12	SC	HX384610	M5 × 10	SC	HX384719	M6 × 20	SC	HX384924	M12 × 16	SC
HX384528	M4 × 5	SC	HX722122	M5 × 12	SC	HX384733	M6 × 30	SC	HX722153	M12 × 20	SC
HX384535	M4 × 6	SC	HX384634	M5 × 16	SC	HX384757	M8 × 10	SC	HX384979	M12 × 40	SC
HX384542	M4 × 8	SC	HX384658	M5 × 25	SC	HX384764	M8 × 12	SC			



DIN 915 Socket Setscrews Dog Point **Grade 14.9**

45 H

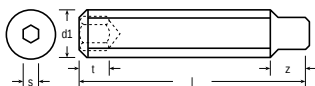

	d1	M4	M5	M6	M8	M10	M12	M16
d2	max.	2.5	3.5	4.0	5.5	7.0	8.5	12
s		2.0	2.5	3.0	4.0	5.0	6.0	8.0
t	max.	2.25	2.75	3.25	4.3	5.3	6.3	10
z	max.	2.5	3.0	3.5	5.0	6.0	7.0	8.0

Product Codes Begin **Q14915** Product Group **41**

Article No.	Size	Finish										
HX384993	M4 × 5	SC	HX385075	M5 × 10	SC	HX385228	M8 × 10	SC	HX722221	M12 × 12	SC	
HX385006	M4 × 6	SC	HX385112	M5 × 25	SC	HX385235	M8 × 12	SC	HX385419	M12 × 16	SC	
HX722160	M4 × 8	SC	HX722191	M6 × 8	SC	HX385242	M8 × 16	SC	HX385426	M12 × 20	SC	
HX722177	M4 × 12	SC	HX385150	M6 × 10	SC	HX385259	M8 × 20	SC	HX385433	M12 × 25	SC	
HX385044	M4 × 16	SC	HX385167	M6 × 12	SC	HX385341	M10 × 25	SC	HX385464	M12 × 40	SC	
HX385051	M5 × 6	SC	HX385174	M6 × 16	SC	HX385358	M10 × 30	SC	HX385532	M16 × 40	SC	
HX385068	M5 × 8	SC	HX385181	M6 × 20	SC	HX385372	M10 × 40	SC				

Socket Screws & Wrenches

DIN 916 Socket Setscrews Plain Cup Point Grade 14.9

45 H

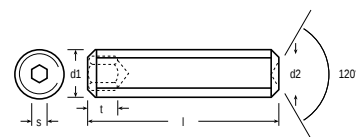

	d1	M2	M2.5	M3	M4	M5	M6	M8	M10	M12	M14	M16	M20
d2 min.		0.75	0.95	1.15	1.75	2.25	2.75	4.7	5.7	7.64	8.64	9.64	13.57
s		0.89	1.27	1.5	2	2.5	3	4	5	6	6	8	10
t max.		1.7	2.0	2.0	2.5	3	3.5	5	6	8	8	10	12

Product Codes Begin **Q149160** Product Group **41**

Article No.	Size	Finish											
HX385655	M3 × 3	Z&C	HX386287	M10 × 25	Z&C	HX365060	M5 × 8	SC	HX365374	M10 × 20	SC		
HX385662	M3 × 4	Z&C	HX386294	M10 × 30	Z&C	HX365077	M5 × 10	SC	HX365381	M10 × 25	SC		
HX722245	M3 × 5	Z&C	HX386317	M10 × 35	Z&C	HX365084	M5 × 12	SC	HX365398	M10 × 30	SC		
HX385693	M3 × 10	Z&C	HX386393	M12 × 12	Z&C	HX365091	M5 × 16	SC	HX386300	M10 × 35	SC		
HX722283	M4 × 4	Z&C	HX364766	M2 × 3	SC	HX365107	M5 × 20	SC	HX386324	M10 × 40	SC		
HX722290	M4 × 5	Z&C	HX385587	M2 × 5	SC	HX365114	M5 × 25	SC	HX386348	M10 × 45	SC		
HX722306	M4 × 6	Z&C	HX364797	M2 × 6	SC	HX365121	M5 × 30	SC	HX365404	M10 × 50	SC		
HX722313	M4 × 8	Z&C	HX364810	M2.5 × 3	SC	HX385938	M5 × 35	SC	HX386355	M10 × 60	SC		
HX385792	M4 × 10	Z&C	HX364827	M2.5 × 4	SC	HX385969	M5 × 50	SC	HX386362	M10 × 70	SC		
HX385808	M4 × 12	Z&C	HX364834	M2.5 × 5	SC	HX365138	M6 × 5	SC	HX365428	M12 × 12	SC		
HX385815	M4 × 16	Z&C	HX364841	M2.5 × 6	SC	HX365145	M6 × 6	SC	HX365435	M12 × 16	SC		
HX385846	M5 × 5	Z&C	HX271026	M2.5 × 8	SC	HX365152	M6 × 8	SC	HX365442	M12 × 20	SC		
HX385853	M5 × 6	Z&C	HX385631	M2.5 × 10	SC	HX365169	M6 × 10	SC	HX365459	M12 × 25	SC		
HX385860	M5 × 8	Z&C	HX364865	M3 × 3	SC	HX365176	M6 × 12	SC	HX365466	M12 × 30	SC		
HX385877	M5 × 10	Z&C	HX364872	M3 × 4	SC	HX365183	M6 × 16	SC	HX365473	M12 × 35	SC		
HX385884	M5 × 12	Z&C	HX364889	M3 × 5	SC	HX365190	M6 × 20	SC	HX365480	M12 × 40	SC		
HX385891	M5 × 16	Z&C	HX364896	M3 × 6	SC	HX365206	M6 × 25	SC	HX365497	M12 × 50	SC		
HX385976	M6 × 6	Z&C	HX722252	M3 × 8	SC	HX365213	M6 × 30	SC	HX365503	M12 × 60	SC		
HX385983	M6 × 8	Z&C	HX364919	M3 × 10	SC	HX365220	M6 × 35	SC	HX386430	M12 × 80	SC		
HX385990	M6 × 10	Z&C	HX364926	M3 × 12	SC	HX365237	M6 × 40	SC	HX365510	M16 × 16	SC		
HX386003	M6 × 12	Z&C	HX364933	M3 × 16	SC	HX386058	M6 × 45	SC	HX365527	M16 × 20	SC		
HX386010	M6 × 16	Z&C	HX385723	M3 × 20	SC	HX386065	M6 × 50	SC	HX386485	M16 × 25	SC		
HX386027	M6 × 20	Z&C	HX385730	M3 × 25	SC	HX386072	M6 × 60	SC	HX365541	M16 × 30	SC		
HX386034	M6 × 25	Z&C	HX722276	M4 × 3	SC	HX386089	M8 × 6	SC	HX386539	M16 × 50	SC		
HX386041	M6 × 30	Z&C	HX364940	M4 × 4	SC	HX365244	M8 × 8	SC	HX386546	M16 × 60	SC		
HX386096	M8 × 8	Z&C	HX364957	M4 × 5	SC	HX365251	M8 × 10	SC	HX365558	M20 × 20	SC		
HX386102	M8 × 10	Z&C	HX364964	M4 × 6	SC	HX365268	M8 × 12	SC	HX386577	M20 × 25	SC		
HX386119	M8 × 12	Z&C	HX364971	M4 × 8	SC	HX365275	M8 × 16	SC	HX386591	M20 × 40	SC		
HX386126	M8 × 16	Z&C	HX364988	M4 × 10	SC	HX365282	M8 × 20	SC					
HX386133	M8 × 20	Z&C	HX364995	M4 × 12	SC	HX365299	M8 × 25	SC					
HX386140	M8 × 25	Z&C	HX365008	M4 × 16	SC	HX365305	M8 × 30	SC					
HX386164	M8 × 35	Z&C	HX365015	M4 × 20	SC	HX365312	M8 × 35	SC					
HX386171	M8 × 40	Z&C	HX365022	M4 × 25	SC	HX365336	M8 × 50	SC					
HX386249	M10 × 10	Z&C	HX385839	M5 × 4	SC	HX365343	M10 × 10	SC					
HX386256	M10 × 12	Z&C	HX365046	M5 × 5	SC	HX365350	M10 × 12	SC					
HX386263	M10 × 16	Z&C	HX365053	M5 × 6	SC	HX365367	M10 × 16	SC					



DIN 916 Socket Setscrews Knurled Cup Point **Grade 14.9**

45 H

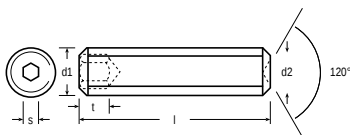

	d1	M4	M5	M6	M8	M10	M12
s		2	2.5	3.0	5.0	5	6
t	max.	2.5	3	3.5	5	6	8

Product Codes Begin **Q14916K** Product Group **41**

Article No.	Size	Finish									
HX722375	M3 × 3	SC	HX363974	M5 × 10	SC	HX364049	M6 × 16	SC	HX386768	M10 × 10	SC
HX363875	M4 × 4	SC	HX363981	M5 × 12	SC	HX364056	M6 × 20	SC	HX386799	M10 × 20	SC
HX363882	M4 × 5	SC	HX363998	M5 × 16	SC	HX364063	M8 × 8	SC	HX722405	M10 × 25	SC
HX363899	M4 × 6	SC	HX364001	M6 × 6	SC	HX364070	M8 × 10	SC	HX386812	M10 × 30	SC
HX363905	M4 × 8	SC	HX364018	M6 × 8	SC	HX364087	M8 × 12	SC	HX386843	M12 × 20	SC
HX722399	M4 × 10	SC	HX364025	M6 × 10	SC	HX364094	M8 × 16	SC	HX386867	M12 × 30	SC
HX363943	M5 × 5	SC	HX364032	M6 × 12	SC	HX386744	M8 × 20	SC			

DIN 267 P/2 Button Flange Socket Screw

Grade 10.9 ISO 898-1

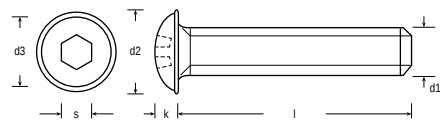

	d1	M3	M4	M5	M6	M8	M10
d2		6.9	9.4	10.8	12.9	16.2	21.9
d3		5.70	7.60	9.5	10.5	14	17.51
k		1.6	2.2	2.7	3.2	4.3	5.5
s		2	2.5	3	4	5	6

Product Codes Begin **Q102670** Product Group **41**

HX450438	M6 × 16	Z&C	HX450391	M6 × 10	SC	HX450551	M6 × 40	SC	HX450674	M8 × 30	SC
HX450568	M6 × 40	Z&C	HX450407	M6 × 12	SC	HX450575	M6 × 45	SC	HX450681	M8 × 40	SC
HX450582	M6 × 45	Z&C	HX450414	M6 × 16	SC	HX450605	M6 × 50	SC	HX721347	M10 × 16	SC
HX450315	M5 × 12	SC	HX450469	M6 × 20	SC	HX450612	M8 × 12	SC	HX450711	M10 × 30	SC
HX450339	M5 × 16	SC	HX450490	M6 × 25	SC	HX450629	M8 × 16	SC			
HX450353	M5 × 20	SC	HX450513	M6 × 30	SC	HX450643	M8 × 20	SC			
HX450360	M5 × 25	SC	HX450520	M6 × 35	SC	HX450650	M8 × 25	SC			

> Socket Screws & Wrenches

ISO 7380 P/1 Button Head Socket Screw

Grade 10.9 ISO 898-1

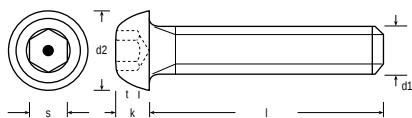

d1	M3	M4	M5	M6	M8	M10	M12	M16
d2	7	6	9.5	10.5	14.	18	21	28
k max.	1.65	2.2	2.75	3.3	4.4	5.5	6.6	8.8
s	2	2.5	3	4	5	6	8	10
t min.	1.04	1.3	1.56	2.08	2.6	3.12	4.16	5.20

Product Codes Begin **Q107380** Product Group **41**

Article No.	Size	Finish	Article No.	Size	Finish	Article No.	Size	Finish	Article No.	Size	Finish
HX378886	M3 × 6	Z&C	HX334288	M8 × 40	Z&C	HX333526	M4 × 6	SC	HX333854	M8 × 50	SC
HX334011	M3 × 8	Z&C	HX191157	M8 × 45	Z&C	HX333533	M4 × 8	SC	HX333861	M8 × 60	SC
HX334028	M3 × 10	Z&C	HX191164	M8 × 50	Z&C	HX333540	M4 × 10	SC	HX379272	M8 × 80	SC
HX334035	M3 × 12	Z&C	HX191171	M8 × 55	Z&C	HX333557	M4 × 12	SC	HX379289	M8 × 90	SC
HX378930	M4 × 6	Z&C	HX191188	M8 × 60	Z&C	HX333564	M4 × 16	SC	HX379296	M8 × 100	SC
HX334042	M4 × 8	Z&C	HX379241	M8 × 65	Z&C	HX333571	M4 × 20	SC	HX191300	M10 × 16	SC
HX334059	M4 × 10	Z&C	HX379265	M8 × 70	Z&C	HX333588	M4 × 25	SC	HX333878	M10 × 20	SC
HX334066	M4 × 12	Z&C	HX451626	M8 × 90	Z&C	HX378961	M4 × 30	SC	HX333885	M10 × 25	SC
HX334073	M4 × 16	Z&C	IC312156	M8 × 100	Z&C	HX378985	M4 × 40	SC	HX333892	M10 × 30	SC
HX378947	M4 × 20	Z&C	HX191195	M10 × 16	Z&C	HX378992	M5 × 6	SC	HX333908	M10 × 35	SC
HX378954	M4 × 25	Z&C	HX334295	M10 × 20	Z&C	HX333595	M5 × 8	SC	HX333915	M10 × 40	SC
HX379005	M5 × 6	Z&C	HX334301	M10 × 25	Z&C	HX333601	M5 × 10	SC	HX333922	M10 × 50	SC
HX379012	M5 × 8	Z&C	HX334318	M10 × 30	Z&C	HX333618	M5 × 12	SC	HX333939	M10 × 60	SC
HX334080	M5 × 10	Z&C	HX334325	M10 × 35	Z&C	HX333625	M5 × 16	SC	HX379302	M10 × 65	SC
HX334097	M5 × 12	Z&C	HX334332	M10 × 40	Z&C	HX333632	M5 × 20	SC	HX191324	M10 × 70	SC
HX334103	M5 × 16	Z&C	HX191201	M10 × 45	Z&C	HX333649	M5 × 25	SC	HX379326	M10 × 80	SC
HX334110	M5 × 20	Z&C	HX334349	M10 × 50	Z&C	HX721361	M5 × 30	SC	HX333960	M12 × 25	SC
HX334127	M5 × 25	Z&C	HX191218	M10 × 60	Z&C	HX333663	M6 × 8	SC	HX333977	M12 × 30	SC
HX379036	M5 × 30	Z&C	HX191225	M10 × 70	Z&C	HX333670	M6 × 10	SC	HX333984	M12 × 35	SC
HX379050	M5 × 35	Z&C	HX191232	M12 × 20	Z&C	HX333687	M6 × 12	SC	HX333991	M12 × 40	SC
HX379074	M5 × 40	Z&C	HX191249	M12 × 25	Z&C	HX379111	M6 × 15	SC	HX379357	M12 × 45	SC
HX191119	M6 × 8	Z&C	HX334356	M12 × 30	Z&C	HX333694	M6 × 16	SC	HX334004	M12 × 50	SC
HX334134	M6 × 10	Z&C	HX334363	M12 × 35	Z&C	HX333700	M6 × 20	SC	HX379364	M12 × 60	SC
HX334141	M6 × 12	Z&C	HX334370	M12 × 40	Z&C	HX333717	M6 × 25	SC	HX379388	M12 × 70	SC
HX334158	M6 × 16	Z&C	HX191256	M12 × 45	Z&C	HX333724	M6 × 30	SC	HX379395	M12 × 75	SC
HX334165	M6 × 20	Z&C	HX191263	M12 × 50	Z&C	HX333731	M6 × 35	SC	HX379401	M12 × 80	SC
HX334172	M6 × 25	Z&C	HX379371	M12 × 60	Z&C	HX333748	M6 × 40	SC	HX379432	M12 × 100	SC
HX334189	M6 × 30	Z&C	HX191270	M12 × 75	Z&C	HX379142	M6 × 45	SC	HX379456	M16 × 30	SC
HX334196	M6 × 35	Z&C	HX379470	M16 × 35	Z&C	HX333755	M6 × 50	SC	HX379494	M16 × 45	SC
HX334202	M6 × 40	Z&C	HX379487	M16 × 40	Z&C	HX379159	M6 × 55	SC	HX191355	M16 × 50	SC
HX191126	M6 × 45	Z&C	HX379500	M16 × 50	Z&C	HX379166	M6 × 60	SC	HX379524	M16 × 70	SC
HX191133	M6 × 50	Z&C	IC360638	M16 × 60	Z&C	HX333762	M8 × 10	SC	HX379531	M16 × 80	SC
HX191140	M6 × 60	Z&C	HX721354	M3 × 4	SC	HX333779	M8 × 12	SC			
HX334219	M8 × 10	Z&C	HX333472	M3 × 5	SC	HX333786	M8 × 16	SC			
HX334226	M8 × 12	Z&C	HX333489	M3 × 6	SC	HX333793	M8 × 20	SC			
HX334233	M8 × 16	Z&C	HX333496	M3 × 8	SC	HX333809	M8 × 25	SC			
HX334240	M8 × 20	Z&C	HX333502	M3 × 10	SC	HX333816	M8 × 30	SC			
HX334257	M8 × 25	Z&C	HX333519	M3 × 12	SC	HX333823	M8 × 35	SC			
HX334264	M8 × 30	Z&C	HX378893	M3 × 16	SC	HX333830	M8 × 40	SC			
HX334271	M8 × 35	Z&C	HX378916	M3 × 20	SC	HX379210	M8 × 45	SC			



UNC Button Head Socket Screws

ANSI B18:3

Product Codes Begin **Q102470** Product Group **41**

HX449999	1/4 UNC×1/2	SC	HX450018	5/6 UNC×1/2	SC
----------	-------------	----	----------	-------------	----

UNC Button Head Socket Screws

BS2470

Product Codes Begin **Q102470** Product Group **41**

HX450001	1/4 UNC×1	SC	HX450025	10.24 UNC×1/2	SC
----------	-----------	----	----------	---------------	----

ISO 7379 Socket Shoulder Screw

Grade 12.9 ISO 898-1

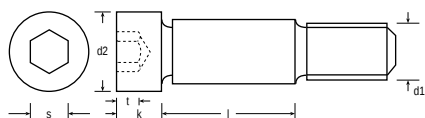

d1	6mm	8mm	10mm	12mm	16mm	20mm	24mm
d2 max.	10	13	16	18	24	30	36
k	4.4	5.4	6.9	8.9	10.9	13.9	15.9
s	3	4	5	6	8	10	12

Product Codes Begin **Q1241680** Product Group **41**

Article No.	Size	Finish	Article No.	Size	Finish	Article No.	Size	Finish
HX363400	6mm (M5) × 10	SC	HX363561	10mm (M8) × 16	SC	HX363721	12mm (M10) × 80	SC
HX363417	6mm (M5) × 12	SC	HX363578	10mm (M8) × 20	SC	HX363738	12mm (M10) × 90	SC
HX363424	6mm (M5) × 16	SC	HX363585	10mm (M8) × 25	SC	HX363745	12mm (M10) × 100	SC
HX363431	6mm (M5) × 20	SC	HX363592	10mm (M8) × 30	SC	HX456676	16mm (M12) × 30	SC
HX363448	6mm (M5) × 25	SC	HX363608	10mm (M8) × 40	SC	HX363752	16mm (M12) × 40	SC
HX363455	6mm (M5) × 30	SC	HX363615	10mm (M8) × 50	SC	HX363769	16mm (M12) × 50	SC
HX363462	6mm (M5) × 40	SC	HX363622	10mm (M8) × 60	SC	HX363776	16mm (M12) × 60	SC
HX456584	6mm (M5) × 50	SC	HX363639	10mm (M8) × 70	SC	HX363783	16mm (M12) × 70	SC
HX456591	6mm (M5) × 60	SC	HX363646	10mm (M8) × 80	SC	HX456683	16mm (M12) × 90	SC
HX363479	8mm (M6) × 12	SC	HX363653	12mm (M10) × 16	SC	HX363806	16mm (M12) × 10	SC
HX363486	8mm (M6) × 16	SC	HX363660	12mm (M10) × 20	SC	HX363813	20mm (M16) × 40	SC
HX363493	8mm (M6) × 20	SC	HX363677	12mm (M10) × 25	SC	HX363837	20mm (M16) × 70	SC
HX363509	8mm (M6) × 25	SC	HX363684	12mm (M10) × 30	SC	HX456713	20mm (M16) × 120	SC
HX363516	8mm (M6) × 30	SC	HX363691	12mm (M10) × 40	SC	HX456720	24mm (M20) × 50	SC
HX363523	8mm (M6) × 40	SC	HX456669	12mm (M10) × 50	SC	HX456751	24mm (M20) × 80	SC
HX363530	8mm (M6) × 50	SC	HX363707	12mm (M10) × 60	SC	HX456768	24mm (M20) × 90	SC
HX456621	10mm (M8) × 12	SC	HX363714	12mm (M10) × 70	SC			

> Socket Screws & Wrenches

DIN 911 Short Arm Hexagon Wrench

Metric

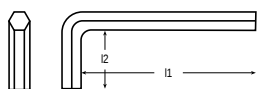

Size	0.89	1.27	1.5	2	2.5	3	4	5
l2	10	14	14	16	18	20	25	28
l1	32	45	45	50	56	63	70	80

6	8	10	12	14	17	19	27
32	36	40	45	56	63	70	100
90	100	112	125	140	160	180	250

Product Codes Begin [Q149110](#) Product Group [41](#)

Article No.	Size	Finish									
HX722030	2mm	Z&C	HX460260	0.89mm	SC	HX349121	3mm	SC	HX349176	10mm	SC
HX460277	2.5mm	Z&C	HX349084	1.27mm	SC	HX349138	4mm	SC	HX349183	12mm	SC
HX460284	3mm	Z&C	HX349091	1.5mm	SC	HX349145	5mm	SC	HX349190	14mm	SC
HX460291	4mm	Z&C	HX349107	2mm	SC	HX349152	6mm	SC	HX349206	17mm	SC
HX460307	5mm	Z&C	HX349114	2.5mm	SC	HX349169	8mm	SC	HX349213	19mm	SC

DIN 911 Short Arm Hexagon Wrench

Imperial

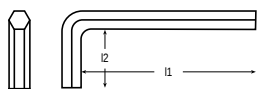

Size	1/16	5/64	3/32	1/8	9/64	5/32	3/16	7/32	5/16	3/8
l2	14	16	18	20	22	25	28	29	36	41
l1	45	50	56	63	70	71	80	93	115	128

Product Codes Begin [Q149112](#) Product Group [41](#)

HX348964	1/16	SC	HX348995	1/8	SC	HX349039	7/32	SC
HX348971	5/64	SC	HX349015	5/32	SC	HX349060	3/8	SC
HX348988	3/32	SC	HX349022	3/16	SC			



DIN 911 Long Arm Hexagon Wrench

Metric

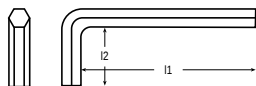

Size	1.5	2	2.5	3	4	5	6
l2	14	16	18	20	25	28	32
l1	90	100	112	126	140	160	180

8	10	12	14	17	19
36	40	45	56	63	70
200	224	250	280	320	360

Product Codes Begin **Q149111** Product Group **41**

Article No.	Size	Finish
HX348896	1.5mm	SC
HX460321	2.0mm	SC
HX348902	2.5mm	SC
HX348919	3mm	SC

HX348926	4mm	SC
HX460338	5mm	SC
HX348933	6mm	SC
HX348940	8mm	SC

HX460369	17mm	SC
----------	------	----

Hexagon Wrench Sets

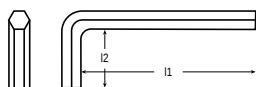

DIN 911 Metric

Set of Allen Keys in blue PVC wallet. Sizes included: 1.27, 1.5, 2.00, 2.5, 3.00, 4.00, 5.00, 6.00, 8.00 and 10.00.

HX348872	No.9	SC
----------	------	----

Product Codes Begin **Q14911P** Product Group **41**

> Socket Screws & Wrenches

Taper Pressure Plugs – 3/4 Inch per Foot Taper Thread

35/40 HRC

BSPT

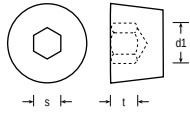

d1	1/8	1/4	3/8	1/2	3/4	1
s	0.186	0.250	0.312	0.375	0.562	0.625
t	0.183	0.245	0.276	0.339	0.370	0.558

Product Codes Begin [Q10BSPT3](#) Product Group [41](#)

Article No.	Size	Finish			
HX363233	1/8 BSPT (3/4)	SC	HX363295	1/2 BSPT (3/4)	SC
HX363257	1/4 BSPT (3/4)	SC	HX363325	3/4 BSPT (3/4)	SC
HX363271	3/8 BSPT (3/4)	SC	HX363332	1 BSPT (3/4)	SC

NPTF

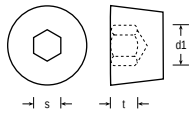

d1	1/8	1/4	3/8	1/2	3/4
s	0.188	0.250	0.312	0.375	0.562
t	0.140	0.218	0.250	0.312	0.312

Product Codes Begin [Q10NPTF3](#) Product Group [41](#)

HX363202	1/4 NPTF (3/4)	SC	HX363219	1/2 NPTF (3/4)	SC
HX455624	3/8 NPTF (3/4)	SC	HX455631	3/4 NPTF (3/4)	SC

Taper Pressure Plugs – 7/8 Inch per Foot Taper Thread

35/40 HRC

NPTF

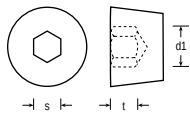

d1	1/8	1/4	3/8	1/2
s	0.188	0.250	0.312	0.375
t	0.141	0.266	0.266	0.329

Product Codes Begin [Q10NPTF7](#) Product Group [41](#)

HX455648	1/8 NPTF (7/8)	Z&C
HX455655	1/4 NPTF (7/8)	SC



Roofing Products

BZP Mushroom Head Roofing Bolts & Square Nuts



Product Codes Begin **^RBN** Product Group **6**

Article No.	Size	Box Qty.						
OJ140896	M5 × 10	200	OJ003702	M6 × 90	100	OJ504896	M8 × 180	50
OJ420943	M5 × 12	200	OJ421063	M6 × 100	100	OJ504902	M8 × 200	50
OJ003634	M5 × 16	200	OJ003719	M6 × 120	100	OJ003818	M8 × 220	50
OJ003641	M5 × 20	200	OJ003726	M6 × 140	100	OJ003825	M8 × 240	25
OJ420950	M5 × 25	200	OJ003733	M6 × 160	100	OJ003849	M10 × 20	100
OJ003658	M5 × 30	200	OJ003740	M6 × 180	100	OJ003856	M10 × 25	100
OJ140902	M5 × 40	200	OJ003757	M6 × 200	100	OJ003863	M10 × 30	100
OJ140919	M5 × 50	200	OJ003764	M8 × 12	100	OJ003870	M10 × 40	100
OJ003665	M6 × 8	200	OJ003771	M8 × 16	100	OJ003887	M10 × 50	50
OJ003672	M6 × 10	200	OJ003788	M8 × 20	100	OJ003894	M10 × 60	50
OJ420967	M6 × 12	200	OJ421070	M8 × 25	100	OJ003900	M10 × 70	50
OJ420974	M6 × 16	200	OJ421087	M8 × 30	100	OJ003917	M10 × 80	50
OJ420981	M6 × 20	200	OJ003795	M8 × 35	100	OJ003924	M10 × 100	50
OJ420998	M6 × 25	100	OJ421094	M8 × 40	100	OJ003931	M10 × 120	25
OJ421001	M6 × 30	100	OJ421100	M8 × 50	100	OJ003948	M10 × 140	25
OJ421018	M6 × 35	100	OJ421117	M8 × 60	100	OJ003955	M10 × 160	25
OJ421025	M6 × 40	100	OJ310367	M8 × 70	50	OJ003962	M10 × 180	25
OJ003689	M6 × 45	100	OJ003801	M8 × 80	50	OJ003979	M10 × 200	25
OJ421032	M6 × 50	100	OJ421131	M8 × 100	50	OJ003986	M10 × 220	25
OJ421049	M6 × 60	100	OJ504865	M8 × 120	50	OJ003993	M10 × 240	25
OJ003696	M6 × 70	100	OJ504872	M8 × 140	50	OJ004006	M10 × 260	25
OJ421056	M6 × 80	100	OJ504889	M8 × 160	50			



BZP Countersunk Gutter Bolts & Nuts

Product Codes Begin **^GBN** Product Group **6**

OJ210766	M6 × 20	200	OJ210780	M6 × 30	200	OJ210803	M6 × 50	200
OJ210773	M6 × 25	200	OJ210797	M6 × 40	200	OJ210810	M6 × 60	100



BZP & Yellow Passivated Hook Bolts & Nuts

Product Codes Begin **^HBN** Product Group **6**

OJ140926	M8 × 60	100	OJ000671	M8 × 140	100	OJ000701	M8 × 220	100
OJ000640	M8 × 80	100	OJ019604	M8 × 150	100	OJ006352	M8 × 240	100
OJ000657	M8 × 100	100	OJ001166	M8 × 160	100	OJ019611	M8 × 260	100
OJ000664	M8 × 120	100	OJ000688	M8 × 180	100	OJ140933	M8 × 280	100
OJ019598	M8 × 130	100	OJ000695	M8 × 200	100	OJ019628	M8 × 300	100



Roofing Products

BZP Round Roofing Washers



Product Codes Begin **9BZRDRWASH** Product Group **5013**

Article No.	Size	Box Qty.
OJ000503	M6 × 20	100
OJ000510	M8 × 21	100
OJ000527	M10 × 30	100

Black Dowty Spat Roofing Washers



Product Codes Begin **9DOWWASH** Product Group **5013**

OJ021928	M6	100
OJ021935	M8	100

Black Dowty Topats



Product Codes Begin **9DOWTOPAT** Product Group **5013**

OJ021911	M8	100
----------	----	-----

Black Selawashers



Product Codes Begin **9SELAWASH** Product Group **5013**

OJ000022	M8 × 28	100
----------	---------	-----

Hook Bolt & Nut with Dowty Topats & Washer



Product Codes Begin **9HBTWB** Product Group **5013**

OJ431796	150mm	10
OJ431802	200mm	10

Black Selacovers



Product Codes Begin **9SELACOV** Product Group **5013**

Article No.	Size	Box Qty.
OJ000060	28 mm	100



Copper Disc Rivet

Product Codes Begin **9CUDR** Product Group **5013**

OJ021218	3/4"	1000
UC1155	3/4"	1000*
UC1150	3/4"	100**

* Tub ** Clam Pack



Copper Strip Slate Clips

Product Codes Begin **9CUSLAC** Product Group **5013**

OJ021232	6 × 1/2 × 19G	100
----------	---------------	-----



Stainless Steel Slate Hooks

A quality alternative method of fixing roofing slates

Product Codes Begin **9SLATEHOOK** Product Group **5013**

OJ143996	80 mm	Slate	500
OJ269580	100 mm	Slate	500
OJ431772	100 mm	Black*	500
OJ431789	110 mm	Black*	500

* BS316



Aluminium Strip Slate Clips

Product Codes Begin **9ALSS** Product Group **5013**

OJ431765	150mm	100
----------	-------	-----



Machine Screws

BZP Countersunk Head Slotted DIN 963

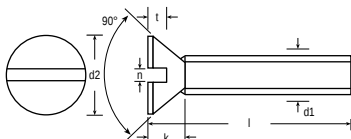

	d1	M3	M3.5	M4	M5	M6	M8	M10	M12
d2		5.6	6.5	7.5	9.2	11	14.5	18	22
k max.		1.65	1.93	2.2	2.5	3	4	5	6
n		0.8	0.8	1	1.2	1.6	2	2.5	3
t min.		0.6	0.7	0.8	1	1.2	1.6	2	2.4

Product Codes Begin **MMS1** Product Group **9**

Article No.	Size	Box Qty.									
OJ175133	M3 × 6	2000	OJ175317	M4 × 20	1000	OJ175508	M6 × 20	250	OJ175669	M10 × 25	100
OJ175140	M3 × 8	2000	OJ175324	M4 × 25	500	OJ175515	M6 × 25	250	OJ175676	M10 × 30	100
OJ175157	M3 × 10	2000	OJ175331	M4 × 30	500	OJ175522	M6 × 30	200	OJ175683	M10 × 35	100
OJ175164	M3 × 12	2000	OJ175348	M4 × 40	500	OJ175539	M6 × 35	200	OJ175690	M10 × 40	100
OJ175171	M3 × 16	1000	OJ175355	M4 × 50	500	OJ175546	M6 × 40	200	OJ175706	M10 × 50	100
OJ175188	M3 × 20	1000	OJ175379	M5 × 10	1000	OJ175553	M6 × 50	100	OJ175713	M10 × 60	100
OJ175195	M3 × 25	1000	OJ175386	M5 × 12	1000	OJ175560	M6 × 60	100	OJ175720	M12 × 25	100
OJ175218	M3.5 × 10	2000	OJ175393	M5 × 16	500	OJ175577	M8 × 16	200	OJ175737	M12 × 30	100
OJ175225	M3.5 × 12	1000	OJ175409	M5 × 20	500	OJ175584	M8 × 20	200	OJ175751	M12 × 40	100
OJ175232	M3.5 × 16	1000	OJ175416	M5 × 25	500	OJ175591	M8 × 25	200	OJ175768	M12 × 45	100
OJ175256	M3.5 × 25	1000	OJ175423	M5 × 30	250	OJ175607	M8 × 30	200	OJ175775	M12 × 50	100
OJ175263	M4 × 6	2000	OJ175447	M5 × 40	250	OJ175614	M8 × 35	200	OJ175782	M12 × 60	100
OJ175270	M4 × 8	2000	OJ175454	M5 × 50	250	OJ175621	M8 × 40	200	OJ175799	M12 × 70	100
OJ175287	M4 × 10	2000	OJ175478	M6 × 10	250	OJ175638	M8 × 50	100	OJ175805	M12 × 75	100
OJ175294	M4 × 12	2000	OJ175485	M6 × 12	250	OJ175645	M8 × 60	100			
OJ175300	M4 × 16	2000	OJ175492	M6 × 16	250	OJ175652	M10 × 20	100			

Brass Countersunk Head Slotted DIN 963

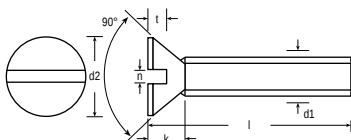

	d1	M2	M3	M3.5	M4	M5	M6	M8	M10
d2		3.8	5.6	6.5	7.5	9.2	11	14.5	18
k max.		1.2	1.65	1.93	2.2	2.5	3	4	5
n		0.5	0.8	0.8	1	1.2	1.6	2	2.5
t min.		0.4	0.6	0.7	0.8	1	1.2	1.6	2

Product Codes Begin **Q60963** Product Group **3506**

HX289328	M2 × 6	200	HX289489	M4 × 10	200	HX289601	M5 × 16	200	HX289724	M6 × 25	200
HX289335	M2 × 12	200	HX289496	M4 × 12	200	HX289618	M5 × 20	200	HX289731	M6 × 30	100
HX289359	M3 × 6	200	HX289502	M4 × 16	200	HX289625	M5 × 25	200	HX289748	M6 × 35	100
HX289366	M3 × 8	200	HX289519	M4 × 20	200	HX289632	M5 × 30	200	HX289755	M6 × 40	100
HX289373	M3 × 10	200	HX289526	M4 × 25	200	HX289649	M5 × 35	200	HX289762	M6 × 50	100
HX289380	M3 × 12	200	HX289533	M4 × 30	200	HX289656	M5 × 40	200	HX289779	M8 × 12	100
HX289397	M3 × 16	200	HX289540	M4 × 40	200	HX289663	M5 × 50	200	HX289786	M8 × 20	100
HX289403	M3 × 25	200	HX289557	M4 × 50	200	HX289670	M5 × 60	200	HX289793	M8 × 25	100
HX289410	M3 × 30	200	HX289564	M4 × 60	200	HX289687	M6 × 10	200	HX289809	M8 × 30	100
HX289458	M3.5 × 30	200	HX289571	M5 × 8	200	HX289694	M6 × 12	200	HX725109	M8 × 40	200
HX289465	M4 × 6	200	HX289588	M5 × 10	200	HX289700	M6 × 16	200	HX289823	M8 × 60	100
HX289472	M4 × 8	200	HX289595	M5 × 12	200	HX289717	M6 × 20	200			

> Machine Screws

BZP Countersunk Head Recessed DIN 965Z

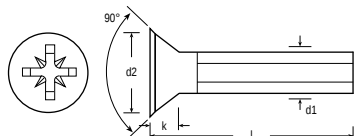

d1	M2.5	M3	M3.5	M4	M5	M6	M8
d2 max.	4.7	5.60	6.5	7.5	9.2	11	14.5
k max.	1.5	1.65	1.93	2.2	2.5	3	4
Recess No.	1	1	2	2	2	3	4

Product Codes Begin **MMS2** Product Group **9**

Article No.	Size	Box Qty.									
OJ175812	M2.5 × 6	2000	OJ175973	M4 × 6	2000	OJ176116	M5 × 16	500	OJ176253	M6 × 40	200
OJ175836	M2.5 × 10	2000	OJ175980	M4 × 8	2000	OJ176123	M5 × 20	500	OJ176260	M6 × 45	100
OJ175843	M2.5 × 12	2000	OJ175997	M4 × 10	2000	OJ176130	M5 × 25	500	OJ176277	M6 × 50	100
OJ175850	M3 × 5	2000	OJ176000	M4 × 12	2000	OJ176147	M5 × 30	250	OJ176284	M6 × 60	100
OJ175867	M3 × 6	2000	OJ176017	M4 × 16	2000	OJ176154	M5 × 35	250	OJ176291	M8 × 16	200
OJ175874	M3 × 8	2000	OJ176024	M4 × 20	1000	OJ176161	M5 × 40	250	OJ176307	M8 × 20	200
OJ175881	M3 × 10	2000	OJ176031	M4 × 25	500	OJ176178	M5 × 50	250	OJ176314	M8 × 25	200
OJ175898	M3 × 12	2000	OJ176048	M4 × 30	500	OJ176185	M6 × 10	250	OJ176321	M8 × 30	200
OJ175904	M3 × 16	1000	OJ176055	M4 × 40	500	OJ176192	M6 × 12	250	OJ176338	M8 × 35	200
OJ175911	M3 × 20	1000	OJ176062	M4 × 50	500	OJ176208	M6 × 16	250	OJ176345	M8 × 40	200
OJ175928	M3 × 25	1000	OJ176079	M5 × 6	1000	OJ176215	M6 × 20	250	OJ176352	M8 × 50	100
OJ175935	M3.5 × 8	2000	OJ176086	M5 × 8	1000	OJ176222	M6 × 25	250			
OJ175942	M3.5 × 10	2000	OJ176093	M5 × 10	1000	OJ176239	M6 × 30	200			
OJ175959	M3.5 × 12	2000	OJ176109	M5 × 12	1000	OJ176246	M6 × 35	200			

BZP Pan Head Slotted DIN 85

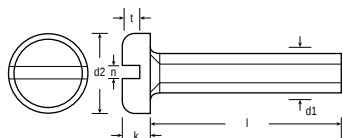

d1	M2.5	M3	M3.5	M4	M5	M6	M8
d2	4.85	6	6.82	8	10	12	16
k	1.43	1.8	2.03	2.4	3	3.6	4.8
n	0.73	0.8	0.93	1.2	1.2	1.6	2
t min.		0.7		1	1.2	1.4	1.9

Product Codes Begin **MMS5** Product Group **9**

OJ176383	M2.5 × 6	2000	OJ176567	M4 × 6	2000	OJ176697	M5 × 12	1000	OJ176826	M6 × 25	200
OJ176406	M2.5 × 10	2000	OJ176574	M4 × 8	2000	OJ176703	M5 × 16	500	OJ176833	M6 × 30	200
OJ176413	M2.5 × 12	2000	OJ176581	M4 × 10	1000	OJ176710	M5 × 20	500	OJ176840	M6 × 35	200
OJ176437	M3 × 5	2000	OJ176598	M4 × 12	1000	OJ176727	M5 × 25	500	OJ176857	M6 × 40	200
OJ176444	M3 × 6	2000	OJ176604	M4 × 16	1000	OJ176734	M5 × 30	250	OJ176864	M6 × 45	200
OJ176451	M3 × 8	2000	OJ176611	M4 × 20	1000	OJ176741	M5 × 35	250	OJ176871	M6 × 50	100
OJ176468	M3 × 10	2000	OJ176628	M4 × 25	500	OJ176758	M5 × 40	250	OJ176888	M8 × 16	200
OJ176475	M3 × 12	2000	OJ176635	M4 × 30	500	OJ176765	M5 × 45	250	OJ176895	M8 × 20	200
OJ176482	M3 × 16	1000	OJ176642	M4 × 40	500	OJ176772	M5 × 50	250	OJ176901	M8 × 25	200
OJ176499	M3 × 20	1000	OJ176659	M4 × 50	250	OJ176789	M6 × 10	500	OJ176918	M8 × 30	100
OJ176505	M3 × 25	1000	OJ176666	M5 × 6	1000	OJ176796	M6 × 12	250	OJ176925	M8 × 40	100
OJ176536	M3.5 × 12	1000	OJ176673	M5 × 8	1000	OJ176802	M6 × 16	250	OJ176932	M8 × 50	100
OJ176543	M3.5 × 16	1000	OJ176680	M5 × 10	1000	OJ176819	M6 × 20	250			



Brass Pan Head Slotted DIN 85

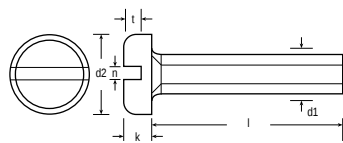

	d1	M2	M2.5	M3	M4	M5	M6
d2		4	5	6	8	10	12
k		1.3	1.5	1.8	2.4	3	3.6
n		0.5	0.6	0.8	1.2	1.2	1.6
t min.		0.5	0.6	0.7	1	1.2	1.4

Product Codes Begin **Q6085** Product Group **3506**

Article No.	Size	Box Qty.									
HX288116	M2×6	200	HX288277	M3×25	200	HX288413	M4×30	200	HX288529	M5×35	200
HX288147	M2×12	200	HX288284	M3×30	200	HX288420	M4×35	200	HX288536	M5×40	200
HX288154	M2.5×6	200	HX288291	M3×40	200	HX288437	M4×40	200	HX288543	M5×50	100
HX288185	M2.5×12	200	HX288338	M4×5	200	HX288444	M4×50	200	HX288567	M6×10	200
HX288208	M3×5	200	HX288345	M4×6	200	HX288451	M4×60	200	HX288574	M6×12	200
HX288215	M3×6	200	HX288352	M4×8	200	HX288468	M5×10	200	HX288581	M6×16	200
HX288222	M3×8	200	HX288369	M4×10	200	HX288475	M5×12	200	HX288598	M6×20	200
HX288239	M3×10	200	HX288376	M4×12	200	HX288482	M5×16	200	HX288604	M6×25	200
HX288246	M3×12	200	HX288383	M4×16	200	HX288499	M5×20	200	HX288611	M6×30	100
HX288253	M3×16	200	HX288390	M4×20	200	HX288505	M5×25	200	HX288628	M6×40	100
HX288260	M3×20	200	HX288406	M4×25	200	HX288512	M5×30	200			

BZP Pan Head Recessed DIN 7985Z

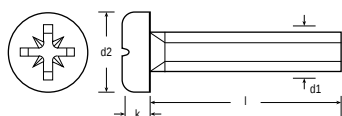

	d1	M2	M2.5	M3	M3.5	M4	M5	M6	M8
d2 max.		4	5	6	7	8	10	12	16
k max.		1.72	2.12	2.52	2.82	3.25	3.95	4.75	6.15
Recess No.		1	1	1	2	2	2	3	4

Product Codes Begin **MMS6** Product Group **9**

OJ176949	M2×6	2000	OJ177120	M3×20	1000	OJ177304	M4×20	1000	OJ177489	M5×50	250
OJ176956	M2×8	2000	OJ177137	M3×25	1000	OJ177311	M4×25	500	OJ177496	M6×10	500
OJ176963	M2×10	2000	OJ177144	M3×30	1000	OJ177328	M4×30	500	OJ177502	M6×12	250
OJ176970	M2×12	2000	OJ177151	M3×35	1000	OJ177335	M4×35	500	OJ177519	M6×16	250
OJ176987	M2.5×5	2000	OJ177168	M3×40	500	OJ177342	M4×40	500	OJ177526	M6×20	250
OJ176994	M2.5×6	2000	OJ177175	M3.5×8	2000	OJ177359	M4×45	250	OJ177533	M6×25	200
OJ177007	M2.5×8	2000	OJ177182	M3.5×10	2000	OJ177366	M4×50	250	OJ177540	M6×30	200
OJ177014	M2.5×10	2000	OJ177199	M3.5×12	1000	OJ177373	M5×6	1000	OJ177557	M6×35	200
OJ177021	M2.5×12	2000	OJ177205	M3.5×16	1000	OJ177380	M5×8	1000	OJ177564	M6×40	200
OJ177038	M2.5×16	1000	OJ177212	M3.5×20	1000	OJ177397	M5×10	1000	OJ177571	M6×45	200
OJ177045	M2.5×20	1000	OJ177229	M3.5×25	1000	OJ177403	M5×12	1000	OJ177588	M6×50	100
OJ177052	M3×4	2000	OJ177236	M3.5×30	500	OJ177410	M5×16	500	OJ177595	M8×12	200
OJ177069	M3×5	2000	OJ177243	M4×5	2000	OJ177427	M5×20	500	OJ177601	M8×16	200
OJ177076	M3×6	2000	OJ177250	M4×6	2000	OJ177434	M5×25	500	OJ177618	M8×20	200
OJ177083	M3×8	2000	OJ177267	M4×8	2000	OJ177441	M5×30	250	OJ177625	M8×25	200
OJ177090	M3×10	2000	OJ177274	M4×10	1000	OJ177458	M5×35	250	OJ177632	M8×30	200
OJ177106	M3×12	2000	OJ177281	M4×12	1000	OJ177465	M5×40	250	OJ177649	M8×40	100
OJ177113	M3×16	1000	OJ177298	M4×16	1000	OJ177472	M5×45	250	OJ177656	M8×50	100

> Machine Screws

BZP Cheese Head Slotted DIN 84

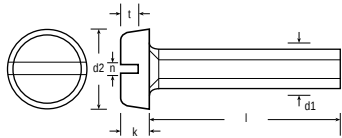

d1	M2.5	M3	M3.5	M4	M5	M6
d2	4.5	5.5	6	7	8.5	10
k	1.6	2	2.4	2.6	3.3	3.9
n	0.6	0.8	1	1.2	1.2	1.6
t min.	0.7	0.85	1	1.1	1.3	1.6

Product Codes Begin **MMS9** Product Group **9**

Article No.	Size	Box Qty.	Article No.	Size	Box Qty.	Article No.	Size	Box Qty.	Article No.	Size	Box Qty.
OJ177700	M2.5 × 10	2000	OJ177861	M4 × 8	2000	OJ177960	M5 × 6	1000	OJ178073	M5 × 60	200
OJ177731	M3 × 6	2000	OJ177878	M4 × 10	1000	OJ177977	M5 × 8	1000	OJ178080	M6 × 10	250
OJ177748	M3 × 8	2000	OJ177885	M4 × 12	1000	OJ177984	M5 × 10	1000	OJ178097	M6 × 12	250
OJ177755	M3 × 10	2000	OJ177892	M4 × 16	1000	OJ177991	M5 × 12	1000	OJ178103	M6 × 16	250
OJ177762	M3 × 12	2000	OJ177908	M4 × 20	1000	OJ178004	M5 × 16	500	OJ178110	M6 × 20	250
OJ177779	M3 × 16	1000	OJ177915	M4 × 25	500	OJ178011	M5 × 20	500	OJ178127	M6 × 25	200
OJ177786	M3 × 20	1000	OJ177922	M4 × 30	250	OJ178028	M5 × 25	500	OJ178134	M6 × 30	200
OJ177793	M3 × 25	1000	OJ177939	M4 × 35	250	OJ178035	M5 × 30	500	OJ178141	M6 × 40	200
OJ177823	M3.5 × 10	2000	OJ177946	M4 × 40	250	OJ178059	M5 × 40	250	OJ178158	M6 × 50	200
OJ177854	M4 × 6	2000	OJ177953	M4 × 50	250	OJ178066	M5 × 50	250			

Brass Cheese Head Slotted DIN 84

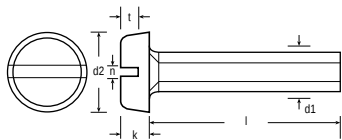

d1	M2	M2.5	M3	M3.5	M4	M5	M6
d2	3.8	4.5	5.5	6	7	8.5	10
k	1.3	1.6	2	2.4	2.6	3.3	3.9
n	0.5	0.6	0.8	1	1.2	1.2	1.6
t min.	0.6	0.7	0.85	1	1.1	1.3	1.6

Product Codes Begin **Q6084** Product Group **3506**

Article No.	Size	Box Qty.	Article No.	Size	Box Qty.	Article No.	Size	Box Qty.	Article No.	Size	Box Qty.
HX287614	M2 × 6	200	HX287782	M3.5 × 6	200	HX287942	M5 × 8	200	HX288079	M6 × 30	100
HX287621	M2 × 8	200	HX287829	M4 × 5	200	HX287959	M5 × 12	200	HX288086	M6 × 35	100
HX287638	M2 × 10	200	HX287836	M4 × 6	200	HX287966	M5 × 16	200	HX288093	M6 × 40	100
HX287645	M2 × 12	200	HX287843	M4 × 8	200	HX287973	M5 × 20	200	HX288109	M6 × 50	100
HX287676	M2.5 × 6	200	HX287850	M4 × 10	200	HX287980	M5 × 25	200			
HX287706	M3 × 5	200	HX287867	M4 × 12	200	HX287997	M5 × 30	200			
HX287713	M3 × 6	200	HX287874	M4 × 16	200	HX288000	M5 × 50	200			
HX287720	M3 × 8	200	HX287881	M4 × 20	200	HX288024	M6 × 10	200			
HX287737	M3 × 10	200	HX287898	M4 × 25	200	HX288031	M6 × 12	200			
HX287744	M3 × 12	200	HX287904	M4 × 30	200	HX288048	M6 × 16	200			
HX287751	M3 × 16	200	HX287911	M4 × 40	200	HX288055	M6 × 20	200			
HX287768	M3 × 20	200	HX287928	M4 × 50	200	HX288062	M6 × 25	200			

Nickel Plated Raised Head Slotted

Product Codes Begin **ZZP101** Product Group **4013**

P10100	M3.5 × 25	100	P10110	M3.5 × 40	100	P10120	M3.5 × 75	100
P10105	M3.5 × 35	100	P10115	M3.5 × 50	100			



BZP Thumbscrews

Shoulderless

Product Codes Begin **EPTSRM** Product Group **47**

Article No.	Size	Box Qty.						
OJ140414	M4 × 10	500	OJ140520	M6 × 25	300	OJ140636	M8 × 40	150
OJ140421	M4 × 12	500	OJ140537	M6 × 30	300	OJ140643	M8 × 50	125
OJ140438	M5 × 10	500	OJ140544	M6 × 40	250	OJ140650	M8 × 60	150
OJ140445	M5 × 12	500	OJ140551	M6 × 50	150	OJ140667	M10 × 20	150
OJ140452	M5 × 20	500	OJ140568	M6 × 60	200	OJ140674	M10 × 25	100
OJ140469	M5 × 25	400	OJ140575	M8 × 12	250	OJ140681	M10 × 30	100
OJ140476	M5 × 30	400	OJ140582	M8 × 15	250	OJ140698	M10 × 35	150
OJ140483	M6 × 10	500	OJ140599	M8 × 20	200	OJ140704	M10 × 40	100
OJ140490	M6 × 12	500	OJ140605	M8 × 25	200			
OJ140506	M6 × 15	500	OJ140612	M8 × 30	200			
OJ140513	M6 × 20	400	OJ140629	M8 × 35	200			



Shouldered

Product Codes Begin **ESTSRM** Product Group **47**

OJ140728	M5 × 10	500	OJ140780	M6 × 25	300	OJ140834	M8 × 20	200
OJ140735	M5 × 12	500	OJ140797	M6 × 30	250	OJ140841	M8 × 25	200
OJ140759	M6 × 12	500	OJ140803	M6 × 40	250	OJ140858	M8 × 30	200
OJ140872	M6 × 15	400	OJ140810	M6 × 50	200			
OJ140773	M6 × 20	350	OJ140889	M8 × 15	200			

Hooks & Eyes

BZP Screw Eyes

Product Codes Begin **9TQSSEYE** Product Group **5024**

Article No.	Size	Box Qty.						
OJ286327	25 × 4	200	OJ286358	40 × 8	200	OJ286389	65 × 14	100
OJ286334	30 × 6	200	OJ286365	45 × 10	100	OJ286396	75 × 18	50
OJ286341	35 × 8	200	OJ286372	55 × 12	100			



BZP Vine Eyes

Product Codes Begin **9TQVEYES** Product Group **5024**

OJ286471	75 × 12	100
OJ286488	100 × 12	100



BZP M Hooks

Product Codes Begin **9TQSMHK** Product Group **5024**

OJ286044	60 × 10	100
OJ286051	80 × 12	100
OJ286068	100 × 18	100



Hooks & Eyes

Vine Eyes to Drive



Article No.	Size	Box Qty.
OJ062945	75mm	100
OJ062952	100mm	100

Product Codes Begin **9VEYED** Product Group **5052**



Metal Dowels

Product Codes Begin **9DOWEL** Product Group **5052**

OJ266305	25mm	500	OJ266336	44mm	500
OJ021843	29mm	500	OJ266343	50mm	500
OJ266312	33mm	500	OJ021898	60mm	500
OJ266329	38mm	500			

Pre-Packed Nails in Clams and Tubs



Complete range on pages 120-136

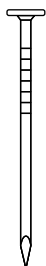

Plain Round Wire Nails

Bright

Self colour for internal use. General purpose nail.

25kg Box

Product Codes Begin **9RWN** Product Group **5037**

Article No.	Approx Size	Approx Count per kg									
OJ121406	25×1.8	1847	OJ121338	65×2.65	€€	346	OJ121260	100×4.5	€€	79	
OJ121383	40×2.36	661	OJ121321	65×3.35	€€	216	OJ121253	125×5.0		42	
OJ121376	40×2.65	542	OJ121314	75×3.35	€€	187	OJ121246	125×5.6	€€	51	
OJ121369	50×2.65	€€	441	OJ121307	75×3.75	€€	145	OJ121239	150×6.0	€€	31
OJ121352	50×3.35	€€	284	OJ121291	90×4.0	€€	106				
OJ121345	60×2.65	€€	372	OJ121277	100×4.0		101				

10kg Tub

Product Codes Begin **UCRWN** Product Group **5033**

UC1870	75×3.75	€€	145
UC1875	100×4.5	€€	79

5kg Tub

Product Codes Begin **UCRWN** Product Group **5033**

UC1840	50×2.65	€€	441	UC1850	75×3.75	€€	145	UC1860	125×5.6	€€	42
UC1845	65×3.35	€€	216	UC1855	100×4.5	€€	79	UC1865	150×6.0	€€	31

2.5kg Tub

Product Codes Begin **UCRWN** Product Group **5033**

UC1805	40×2.65		661	UC1820	75×3.75	€€	145	UC1835	150×6.0	€€	31
UC1810	50×2.65	€€	441	UC1825	100×4.5	€€	79				
UC1815	65×3.35	€€	216	UC1830	125×5.6	€€	42				

2.5kg Polybag

Product Codes Begin **9RWNTQ** Product Group **5035**

PB400	25×1.8		1847	PB403	65×3.35	€€	216	PB406	125×5.6	€€	42
PB401	40×2.36		661	PB404	75×3.75	€€	145	PB407	150×6.0	€€	31
PB402	50×2.65	€€	441	PB405	100×4.5	€€	79				

1kg Polybag

Product Codes Begin **9RWNTQ** Product Group **5035**

PB302	50×2.65	€€	441	PB304	75×3.75	€€	145	PB306	125×5.00	€€	42
PB303	65×3.35	€€	216	PB305	100×4.50	€€	79	PB307	150×6.00	€€	31

500g Polybag

Product Codes Begin **9RWNTQ** Product Group **5035**

PB200	25×1.8		1847	PB203	65×3.35	€€	216	PB206	125×5.6	€€	42
PB201	40×2.36		661	PB204	75×3.75	€€	145	PB207	150×6.0	€€	31
PB202	50×2.65	€€	441	PB205	100×4.5	€€	79				

500g Clam

Product Codes Begin **UCRWN** Product Group **5033**

UC1765	25×1.8		1847	UC1780	65×3.35	€€	216	UC1795	125×5.6	€€	42
UC1770	40×2.35	€€	661	UC1785	75×3.75	€€	145	UC1800	150×6.0	€€	31
UC1775	50×2.65	€€	441	UC1790	100×4.5	€€	79				

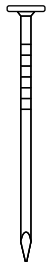

Plain Round Wire Nails

Galvanised Galvanised heavy duty, for external use. General purpose nail.

25kg Box

Product Codes Begin **9GALVRWN** Product Group **5037**

Article No.	Size	Approx. Count per kg								
OJ121697	25×1.8	1662	OJ121635	65×2.65	CE	311	OJ121574	100×4.5	CE	71
OJ121680	30×2.0	1116	OJ121628	65×3.35	CE	194	OJ144009	125×5.6	CE	36
OJ121673	40×2.36	595	OJ121611	75×3.35	CE	168	OJ121550	150×6.0	CE	27
OJ121666	40×2.65	CE	487	OJ121604	75×3.75	CE	130			
OJ121659	50×2.36	484	OJ121598	90×4.0		95				
OJ121642	50×2.65	CE	396	OJ121581	100×4.0	90				

10kg Tub

Product Codes Begin **UCGALVRWN** Product Group **5038**

UC1485	75×3.75	CE	130	UC1495	125×5.6	CE	36
UC1490	100×4.5	CE	71	UC1500	150×6.0	CE	27

5kg Tub

Product Codes Begin **UCGALVRWN** Product Group **5038**

UC1440	40×2.65	CE	595	UC1460	75×3.75	CE	130	UC1475	150×6.0	CE	27
UC1445	50×2.65	CE	396	UC1465	100×4.5	CE	71				
UC1450	65×2.65	CE	311	UC1470	125×5.6	CE	36				

2.5kg Tub

Product Codes Begin **UCGALVRWN** Product Group **5038**

UC1400	40×2.65	CE	595	UC1414	65×3.35	CE	194	UC1430	125×5.6	CE	36
UC1405	50×2.65	CE	396	UC1420	75×3.75	CE	130	UC1435	150×6.0	CE	27
UC1410	65×2.65	CE	311	UC1425	100×4.5	CE	71				

2.5kg Polybag

Product Codes Begin **9GALVRWNTQ** Product Group **5035**

PB410	40×2.36	595	PB412	65×3.35	CE	194	PB416	125×5.0	CE	48	
PB411	50×2.65	CE	396	PB414	75×3.75	CE	130	PB417	150×6.0	CE	27
PB413	65×2.65	CE	311	PB415	100×4.5	CE	71				

1kg Polybag

Product Codes Begin **9GALVRWNTQ** Product Group **5035**

PB310	40×2.36	595	PB314	75×3.75	CE	130	PB317	150×6.0	CE	27
PB311	50×2.65	CE	396	PB315	100×4.5	CE	71			
PB313	65×2.65	CE	311	PB316	125×5.0	CE	48			

500g Polybag

Product Codes Begin **9GALVRWNTQ** Product Group **5035**

PB210	40×2.36	595	PB213	65×2.65	CE	311	PB214	75×3.75	CE	130	
PB211	50×2.65	CE	396	PB212	65×3.35	CE	194	PB215	100×4.5	CE	71

500g Clam

Product Codes Begin **UCGALVRWN** Product Group **5038**

UC1360	40×2.65	CE	595	UC1415	65×3.35	CE	194	UC1430	125×5.6	CE	
UC1365	50×2.65	CE	396	UC1420	75×3.75	CE	130	UC1435	150×6.0	CE	
UC1410	65×2.65	CE	311	UC1425	100×4.5	CE	71				



Lost Head Round Wire Nails

Bright Self colour for internal use. Easily hidden; reduces timber deformation.

Article No. / Approx. Count per kg Size

25kg Box

Product Codes Begin **9LHRWN** Product Group **5037**

OJ121468	40 x 2.36	760
OJ121451	50 x 3.0	360
OJ121444	60 x 3.35	270
OJ121437	65 x 3.35	240
OJ121420	75 x 3.75	160

2.5kg Polybag

Product Codes Begin **9LHRWNTQ** Product Group **5035**

PB424	40 x 2.36	760
PB425	50 x 3.0	360
PB426	65 x 3.35	240

500g Polybag

Product Codes Begin **9LHRWNTQ** Product Group **5035**

PB224	40 x 2.36	760
PB225	50 x 3.0	360
PB226	65 x 3.35	240

2.5kg Tub

Product Codes Begin **UCLHRWN** Product Group **5033**

UC1615	40 x 2.36	760
UC1620	50 x 3.0	360
UC1625	65 x 3.35	240

500g Clam

Product Codes Begin **UCLHRWN** Product Group **5033**

UC1600	40 x 2.36	760
UC1605	50 x 3.0	360
UC1610	65 x 3.35	240

Sheradised

 Sheradised for external use. Easily hidden; reduces timber deformation.

25kg Box

Product Codes Begin **9SHERLHRWN** Product Group **5037**

OJ211305	40 x 2.36	700
OJ699349	50 x 2.65	386
OJ211312	65 x 3.35	220

500g Polybag

Product Codes Begin **9SHERLHRWTQ** Product Group **5035**

PB227	40 x 2.36	700
PB228	50 x 2.65	386
PB229	65 x 3.35	220

2.5kg Polybag

Product Codes Begin **9SHERLHRWTQ** Product Group **5035**

PB429	65 x 3.35	220
-------	-----------	-----

500g Clam

Product Codes Begin **UCSHERLHRWN** Product Group **5033**

UC1895	40 x 2.36	700
UC1900	50 x 2.65	386
UC1905	65 x 3.35	220

1kg Polybag

Product Codes Begin **9SHERLHRWTQ** Product Group **5035**

PB329	65 x 3.35	220
-------	-----------	-----

Galvanised

 Galvanised for external use. Easily hidden; reduces timber deformation.

25kg Box

Product Codes Begin **9GALVLRWN** Product Group **5037**

OJ122427	65 x 3.35	216
----------	-----------	-----

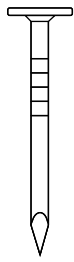

Clout Nails

Galvanised

Galvanised heavy duty, for external use. For roofing slates and tiles.

25kg Box

Product Codes Begin **9GALVCN** Product Group **5037**

Article No.	Size	Approx Count per kg						
OJ121840	20 × 2.65	1035	OJ121796	40 × 2.36	700	OJ121741	65 × 2.65	194
OJ121833	25 × 2.65	815	OJ121789	40 × 2.65	570	OJ121734	65 × 3.35	189
OJ121802	30 × 3.0	540	OJ121772	40 × 3.35	350	OJ121727	65 × 3.75	180
OJ121819	30 × 2.65	660	OJ121765	50 × 2.65	430	OJ121710	75 × 3.75	150
OJ121826	30 × 2.36	830	OJ121758	50 × 3.35	290	OJ121703	100 × 4.5	75

5kg Tub

Product Codes Begin **UCGALVCN** Product Group **5035**

UC1255	30 × 2.65	660
UC1260	40 × 2.65	570
UC1265	50 × 3.35	290

2.5kg Tub

Product Codes Begin **UCGALVCN** Product Group **5035**

UC1210	30 × 2.65	660	UC1225	50 × 2.65	430	UC1240	65 × 3.75	180
UC1215	40 × 2.65	570	UC1230	50 × 3.35	290	UC1245	75 × 3.75	150
UC1220	40 × 3.35	350	UC1235	65 × 2.65	150	UC1250	100 × 4.5	75

2.5kg Polybag

Product Codes Begin **9GALVCNTQ** Product Group **5035**

PB438	30 × 2.65	660	PB442	50 × 2.65	430	PB444	75 × 3.75	150
PB440	40 × 2.65	570	PB441	50 × 3.35	290	PB445	100 × 4.5	75
PB439	40 × 3.35	350	PB443	65 × 3.75	180			

500g Polybag

Product Codes Begin **9GALVCNTQ** Product Group **5035**

PB237	25 × 2.65	815	PB239	40 × 3.35	350	PB243	65 × 3.75	180
PB238	30 × 2.65	660	PB242	50 × 2.65	430	PB244	75 × 3.75	150
PB240	40 × 2.65	570	PB241	50 × 3.35	290			

500g Clam

Product Codes Begin **UCGALVCN** Product Group **5035**

UC1160	25 × 2.65	815	UC1175	40 × 3.35	350	UC1190	65 × 2.65	150
UC1165	30 × 2.65	660	UC1180	50 × 2.65	430	UC1195	65 × 3.75	180
UC1170	40 × 2.65	570	UC1185	50 × 3.35	290	UC1200	75 × 3.75	150

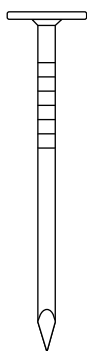

Extra Large Head Clout Nails

Galvanised

Galvanised heavy duty, for external use. For non rigid roofing felt, smooth or grit surface.

25kg Box

Product Codes Begin **9GALVELHCN** Product Group **5037**

Article No.	Approx Count per kg Size			
OJ121918	13 × 3.0	780	OJ121871	30 × 3.0 420
OJ121901	15 × 3.0	650	OJ121864	40 × 3.0 350
OJ121895	20 × 3.0	580	OJ121857	50 × 3.0 290
OJ121888	25 × 3.0	485		

10kg Box

Product Codes Begin **9GALVELHCN** Product Group **5037**

OJ201337	8 × 3.0	1000
OJ201344	10 × 3.0	910

5kg Tub

Product Codes Begin **UCGALVELHCNT** Product Group **5033**

UC1330	13 × 3.0	780	UC1340	30 × 3.0	420
UC1335	20 × 3.0	580	UC1345	40 × 3.0	350

2.5kg Tub

Product Codes Begin **UCGALVELHCN** Product Group **5033**

UC1310	13 × 3.0	780	UC1320	30 × 3.0	420
UC1315	20 × 3.0	580	UC1325	40 × 3.0	350

2.5kg Polybag

Product Codes Begin **9GALVELHCTQ** Product Group **5035**

PB446	13 × 3.0	780	PB449	40 × 3.0	350
PB447	20 × 3.0	580	PB480	50 × 3.0	290
PB448	30 × 3.0	420			

500g Polybag

Product Codes Begin **9GALVELHCTQ** Product Group **5035**

PB246	13 × 3.0	780	PB248	30 × 3.0	420
PB247	20 × 3.0	580	PB249	40 × 3.0	350
PB245	25 × 3.0	485	PB249	50 × 3.0	290

500g Clam

Product Codes Begin **UCGALVELHCN** Product Group **5033**

UC1280	13 × 3.0	780	UC1295	25 × 3.0	485
UC1285	15 × 3.0	650	UC1300	30 × 3.0	420
UC1290	20 × 3.0	580	UC1305	40 × 3.0	350

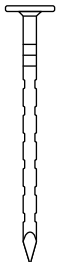

Jagged Nails

Galvanised Galvanised heavy duty, for external use. For timber cladding.

Article No.

Approx. Count
per kg
Size

25kg Box

Product Codes Begin **9GALVPN** Product Group **5037**

OJ121932	30 × 2.65	700
OJ121925	40 × 2.65	570

2.5kg Polybag

Product Codes Begin **9GALVPNTQ** Product Group **5035**

PB450	30 × 2.65	700
PB451	40 × 2.65	570

500g Polybag

Product Codes Begin **9GALVPNTQ** Product Group **5035**

PB250	30 × 2.65	700
PB251	40 × 2.65	570

500g Clam

Product Codes Begin **UCGALVPN** Product Group **5033**

UC1350	30 × 2.65	700
UC1355	40 × 2.65	570

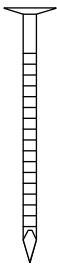

Drywall Nails

Zinc & Yellow Passivated Recommended for fixing plasterboard

25kg Box

Product Codes Begin **9ZPPASSARSN** Product Group **5037**

OJ574974	30 × 2.65	798
OJ575001	40 × 2.65	547
OJ146935	50 × 2.65	418

2.5kg Tub

Product Codes Begin **UCZPPASSARSN** Product Group **5033**

UC1965	40 × 2.65	547
--------	-----------	-----

2.5kg Polybag

Product Codes Begin **9ZPPASSARSNTQ** Product Group **5035**

PB474	30 × 2.65	798
PB475	40 × 2.65	547

1kg Polybag

Product Codes Begin **9ZPPASSARSNTQ** Product Group **5035**

PB374	30 × 2.65	798
PB375	40 × 2.65	547

500g Clam

Product Codes Begin **UCZPPASSARSN** Product Group **5033**

UC1945	30 × 2.65	798
UC1950	40 × 2.65	547
UC1955	50 × 2.65	418

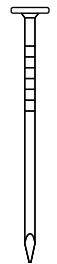

Wire Lath Nails

Galvanised

Galvanised heavy duty, for external use. General purpose nail.

25kg Box

Product Codes Begin **9GALVWLN** Product Group **5037**

OJ122519	30 × 2.0	760
----------	----------	-----



Annular Ring Shank Nails

Bright Self colour for internal use. Strong grip with good holding power.

Article No.

Approx. Count per kg Size

25kg Box

Product Codes Begin **9ARSN** Product Group **5037**

OJ122311	20 × 2.0	1900
OJ122304	25 × 2.0	1430
OJ122298	30 × 2.36	840
OJ122281	40 × 2.65	575
OJ122274	50 × 2.65	440
OJ122267	50 × 3.35	290
OJ122250	60 × 3.35	255
OJ122243	65 × 3.35	230
OJ122236	75 × 3.75	154
OJ122229	100 × 5.0	66

5kg Tub

Product Codes Begin **UCARSN** Product Group **5033**

UC1075	65 × 3.35	230
--------	-----------	-----

2.5kg Tub

Product Codes Begin **UCARSN** Product Group **5033**

UC1055	20 × 2.0	1900
UC1060	40 × 2.65	575
UC1065	50 × 2.65	440
UC1070	65 × 3.35	230

2.5kg Polybag

Product Codes Begin **9ARSNTQ** Product Group **5035**

PB431	25 × 2.0	1430
PB432	40 × 2.65	575
PB433	50 × 2.65	440
PB434	65 × 3.35	230
PB435	75 × 3.75	154

500g Polybag

Product Codes Begin **9ARSNTQ** Product Group **5035**

PB230	20 × 2.0	1900
PB231	25 × 2.0	1430
PB232	40 × 2.65	575
PB233	50 × 2.65	440
PB234	65 × 3.35	230
PB235	75 × 3.75	154
PB236	100 × 5.0	66

500g Clam

Product Codes Begin **UCARSN** Product Group **5033**

UC1030	20 × 2.0	1900
UC1035	25 × 2.0	1430
UC1040	40 × 2.65	575
UC1045	50 × 2.65	440
UC1050	65 × 3.35	230

Sheradised

Sheradised for external use. Strong grip with good holding power.

25kg Box

Product Codes Begin **9SHERARSN** Product Group **5037**

OJ211251	40 × 2.65	552
OJ211268	50 × 2.65	423
OJ211275	65 × 3.35	221
OJ211282	75 × 3.75	147
OJ211299	100 × 5.0	65

2.5kg Polybag

Product Codes Begin **9SHERARSNTQ** Product Group **5035**

PB7136	50 × 2.65	423
--------	-----------	-----

500g Polybag

Product Codes Begin **9SHERARSNTQ** Product Group **5035**

PB7134	50 × 2.65	423
--------	-----------	-----

500g Clam

Product Codes Begin **UCSHERARSN** Product Group **5033**

UC1880	40 × 2.65	552
UC1885	50 × 2.65	423
UC1890	65 × 3.35	221



Oval Brad Nails

Bright Self colour for internal use. For general joinery; reduces wood splitting.

Article No. / Approx. Count per kg / Size

25kg Box

Product Codes Begin **9OBN** Product Group **5037**

OJ121543	25mm	2530
OJ121536	30mm	1480
OJ121529	40mm	940
OJ121512	50mm	470
OJ121505	65mm	230
OJ121499	75mm	125
OJ121482	100mm	64

5kg Tub

Product Codes Begin **UCOBN** Product Group **5033**

UC1685	40mm	940
--------	------	-----

2.5kg Tub

Product Codes Begin **UCOBN** Product Group **5033**

UC1660	40mm	940
UC1665	50mm	470
UC1670	65mm	230
UC1675	75mm	125
UC1680	100mm	64

2.5kg Polybag

Product Codes Begin **9OBN** Product Group **5035**

PB418	25mm	2530
PB419	40mm	940
PB420	50mm	470
PB421	65mm	230
PB422	75mm	125
PB423	100mm	64

500g Polybag

Product Codes Begin **9OBN** Product Group **5035**

PB218	25mm	2530
PB219	40mm	940
PB220	50mm	470
PB221	65mm	230
PB222	75mm	125
PB223	100mm	64

500g Clam

Product Codes Begin **UCOBN** Product Group **5033**

UC1635	25mm	2530
UC1640	40mm	940
UC1645	50mm	470
UC1650	65mm	230
UC1655	75mm	125

Sheradised

Sheradised for external use. For general joinery; reduces wood splitting.

25kg Box

Product Codes Begin **9SHEROBN** Product Group **5037**

PB7089	40mm	893
PB7090	50mm	447

Galvanised

Galvanised for external use. For general joinery; reduces wood splitting.

25kg Box

Product Codes Begin **9GALVOBN** Product Group **5037**

OJ122465	40mm	893
OJ122458	50mm	447
OJ122441	65mm	219

2.5kg Polybag

Product Codes Begin **9GALVOBNTQ** Product Group **5035**

PB7043	65mm	219
--------	------	-----

500g Polybag

Product Codes Begin **9GALVOBNTQ** Product Group **5035**

PB7045	40mm	893
PB7046	50mm	447



Panel Pins

Bright

Self colour for internal use. For lightweight work and decorative purposes.

Article No. Approx Count per kg
Size

25kg Box

Product Codes Begin **9PP** Product Group **5037**

OJ122410	15 × 1.25	8800
OJ122397	20 × 1.6	3140
OJ122373	25 × 1.6	2340
OJ122366	30 × 1.6	1900
OJ122359	40 × 1.6	1590
OJ122342	50 × 2.0	770

2.5kg Polybag

Product Codes Begin **9PPTQ** Product Group **5035**

PB455	25 × 1.4	3090
PB456	30 × 1.6	1900
PB457	40 × 1.6	1590
PB458	50 × 2.0	770

500g Polybag

Product Codes Begin **9PPTQ** Product Group **5035**

PB253	15 × 1.25	8800
PB254	20 × 1.4	3970
PB255	25 × 1.4	3090
PB256	30 × 1.6	1900
PB257	40 × 1.6	1590
PB258	50 × 2.0	770

500g Clam

Product Codes Begin **UCPP** Product Group **5033**

UC1740	20 × 1.6	3140
UC1745	25 × 1.6	2340
UC1750	30 × 1.6	1900
UC1755	40 × 1.6	1590
UC1760	50 × 2.0	770

250g Polybag

Product Codes Begin **9PPTQ** Product Group **5035**

PB154	20 × 1.4	3970
PB155	25 × 1.4	3090
PB7097	30 × 1.6	1900
PB7098	40 × 1.6	1590
PB7099	50 × 2.0	770

Sheradised

Sheradised for external use. For lightweight work and decorative purposes.

25kg Box

Product Codes Begin **9SHERPP** Product Group **5037**

OJ281803	20 × 1.6	3652
OJ281810	25 × 1.6	2842
OJ211350	30 × 1.6	1748
OJ211367	40 × 1.6	1462

500g Polybag

Product Codes Begin **9SHERPPTQ** Product Group **5035**

PB259	20 × 1.6	3652
PB260	25 × 1.6	2842
PB261	30 × 1.6	1748
PB262	40 × 1.6	1462

500g Clam

Product Codes Begin **UCSHERPP** Product Group **5033**

UC1915	25 × 1.6	2842
UC1920	30 × 1.6	1748
UC1925	40 × 1.6	1462



Square Hardboard Nail

Coppered

For lightweight work

Article No. Size

250g Polybag

Product Codes Begin **9CUSQHNTQ** Product Group **5035**

PB173	20 × 1.4
-------	----------



Veneer Pins

Bright

For use with wood veneers

25kg Box

Product Codes Begin **9VP** Product Group **5037**

OJ135601	20 × 1.00
OJ135618	25 × 1.00

250g Polybag

Product Codes Begin **9VPTQ** Product Group **5035**

PB190	20 × 1.00
PB191	25 × 1.00

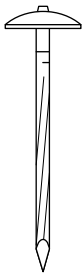

Springhead Roofing Nail

Galvanised

Galvanised heavy duty, for external use. For roofing panels and corrugated sheets.

Article No. Approx Count per kg Size

10kg Box

Product Codes Begin **9GALVSPRN** Product Group **5037**

OJ122526	65 × 3.35	146
----------	-----------	-----

2.5kg Tub

Product Codes Begin **UCGALVSPRN** Product Group **5033**

UC1510	65 × 3.35	146
--------	-----------	-----

1kg Tub

Product Codes Begin **UCGALVSPRN** Product Group **5033**

UC1505	65 × 3.35	146
--------	-----------	-----

1kg Polybag

Product Codes Begin **9GALVSPRNTQ** Product Group **5035**

PB376	65 × 3.35	146
-------	-----------	-----

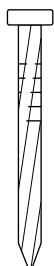

Square Twisted Nails

Sheradised

Sheradised for external use. For joist hangers and restraint straps.

Article No. / Approx Count per kg Size

25kg Box

Product Codes Begin **9SHERSQTN** Product Group **5037**

OJ699325	30 × 3.75	CE	270
----------	-----------	----	-----

5kg Tub

Product Codes Begin **UCSHERSQTN** Product Group **5033**

UC1940	30 × 3.75	CE	270
--------	-----------	----	-----

2.5kg Tub

Product Codes Begin **UCSHERSQTN** Product Group **5033**

UC1935	30 × 3.75	CE	270
--------	-----------	----	-----

2.5kg Polybag

Product Codes Begin **9SHERSQNTQ** Product Group **5035**

PB477	30 × 3.75	CE	270
-------	-----------	----	-----

500g Polybag

Product Codes Begin **9SHERSQNTQ** Product Group **5035**

PB7129	30 × 3.75	CE	270
--------	-----------	----	-----

500g Clam

Product Codes Begin **UCSHERSQTN** Product Group **5033**

UC1930	30 × 3.75	CE	270
--------	-----------	----	-----

Galvanised

Galvanised heavy duty, for external use. For joist hangers and restraint straps.

25kg Box

Product Codes Begin **9GALVSQTN** Product Group **5037**

OJ122540	30 × 3.75	CE	285
OJ122533	40 × 3.75	CE	190

2.5kg Tub

Product Codes Begin **UCGALVSQTN** Product Group **5033**

UC1520	30 × 3.75	CE	285
--------	-----------	----	-----

2.5kg Polybag

Product Codes Begin **9GALVSQNTQ** Product Group **5035**

PB452	30 × 3.75	CE	285
-------	-----------	----	-----

1kg Polybag

Product Codes Begin **9GALVSQNTQ** Product Group **5035**

PB352	30 × 3.75	CE	285
-------	-----------	----	-----

500g Polybag

Product Codes Begin **9GALVSQNTQ** Product Group **5035**

PB252	30 × 3.75	CE	285
-------	-----------	----	-----

500g Clam

Product Codes Begin **UCGALVSQTN** Product Group **5033**

UC1515	30 × 3.75	CE	285
--------	-----------	----	-----

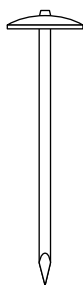

Washerhead Slab Nails

Galvanised

Galvanised heavy duty, for external use.

For use in fixing insulation and soundproofing to walls.

25kg Box

Product Codes Begin **9GALVWHS LAB** Product Group **5037**

OJ122502	100 × 3.35	90
OJ122496	125 × 3.75	70
OJ368740	150 × 3.75	63
OJ368757	180 × 4.5	50

1kg Polybag

Product Codes Begin **9GALVWHS LABTQ** Product Group **5035**

PB389	100 × 3.35	90
-------	------------	----

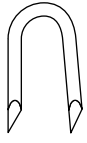

Staples

Electro Galvanised

Galvanised heavy duty, for external use. For fencing, netting and wire.

Article No. / Approx Count per kg Size

25kg Box

Product Codes Begin **9GALVSTAP** Product Group **5037**

OJ122625	15 × 1.6	2191
OJ122618	20 × 2.0	1079
OJ122601	25 × 2.65	486
OJ122595	30 × 3.55	226
OJ122588	40 × 4.0	136
OJ122571	50 × 5.0	70

5kg Tub

Product Codes Begin **UCGALVSTAP** Product Group **5033**

UC1575	30 × 3.55	226
UC1580	40 × 4.0	136

2.5kg Tub

Product Codes Begin **UCGALVSTAP** Product Group **5033**

UC1550	20 × 2.0	1079
UC1555	25 × 2.65	486
UC1560	30 × 3.55	226
UC1565	40 × 4.0	136
UC1570	50 × 5.0	70

2.5kg Polybag

Product Codes Begin **9GALVSTAPTQ** Product Group **5035**

PB464	20 × 2.0	1079
PB465	25 × 2.65	486
PB466	30 × 3.55	226
PB467	40 × 4.0	136
PB468	50 × 5.0	70

1kg Polybag

Product Codes Begin **9GALVSTAPTQ** Product Group **5035**

PB393	15 × 1.6	2191
PB394	20 × 2.0	1079
PB395	25 × 2.65	486
PB396	30 × 3.55	226
PB397	40 × 4.0	136
PB398	50 × 5.0	70

500g Polybag

Product Codes Begin **9GALVSTAPTQ** Product Group **5035**

PB263	15 × 1.6	2191
PB264	20 × 2.0	1079
PB265	25 × 2.65	486
PB266	30 × 3.55	226
PB267	40 × 4.0	136

500g Clam

Product Codes Begin **UCGALVSTAP** Product Group **5033**

UC1525	15 × 1.6	2191
UC1530	20 × 2.0	1079
UC1535	25 × 2.65	486
UC1540	30 × 3.55	226
UC1545	40 × 4.0	136

250g Polybag

Product Codes Begin **9GALVSTAPTQ** Product Group **5035**

PB193	15 × 1.60	2191
PB194	20 × 2.00	1079
PB195	25 × 2.65	486
PB196	30 × 3.55	226
PB197	40 × 4.00	136
PB198	50 × 5.00	70

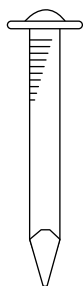

Wire Pipe Nails

Bright For pipes and draining systems

Article No.

Approx. Count
per kg
Size

25kg Box

Product Codes Begin **9WPIPEN** Product Group **5037**

OJ155515	75 × 8.0	31
OJ155522	100 × 8.0	24



Cut Clasp Nails

Bright Self colour for internal use

Article No.

Approx. Count
per kg
Size

25kg Box

Product Codes Begin **9CN** Product Group **5037**

OJ012650	40mm	616
OJ012667	50mm	286
OJ012681	65mm	171
OJ012698	75mm	103
OJ012711	100mm	48

2.5kg Tub

Product Codes Begin **UCCN** Product Group **5033**

UC1135	50mm	286
UC1140	65mm	171
UC1145	75mm	103

2.5kg Polybag

Product Codes Begin **9CNTQ** Product Group **5035**

PB469	50mm	286
PB470	65mm	171
PB471	75mm	103
PB472	100mm	48

500g Polybag

Product Codes Begin **9CNTQ** Product Group **5035**

PB269	50mm	286
PB270	65mm	171
PB271	75mm	103
PB272	100mm	48

500g Clam

Product Codes Begin **UCCN** Product Group **5033**

UC1120	40mm	616
UC1125	50mm	286
UC1130	65mm	171



Cut Floor Brads

Bright Self colour for internal use. For fixing floor boards.

25kg Box

Product Codes Begin **9FB** Product Group **5037**

OJ024394	50mm	264
OJ211244	60mm	198
OJ024417	65mm	154

2.5 kg Polybag

Product Codes Begin **9FBTQ** Product Group **5035**

PB492	65mm	154
-------	------	-----

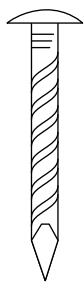

Cone Head Drive Screws

Galvanised Galvanised heavy duty, for external use

Article No. / Approx Count per kg
Size

25kg Box | 9GALVCHDS Product Group 5017

OJ242613	65mm	75
OJ242620	75mm	65
OJ245171	100mm	33
OJ170091	125mm	29
OJ170077	150mm	17

1kg Polybag
Product Codes Begin 9GALVCHDSTQ Product Group 5035

PB383	65mm	75
PB384	75mm	65
PB385	100mm	33
PB386	115mm	31
PB387	125mm	29
PB388	150mm	17

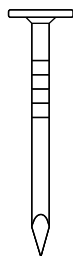

Roofing Specialist Nails

Aluminium Clout Nails

Aluminium – rustproof. For roofing and insulation board.

Article No. / Approx Count per kg
Size

4kg Tub

Product Codes Begin 9ALCNT Product Group 5039

OJ431635	30 × 2.65	660	OJ431697	50 × 3.35	290
OJ431642	38 × 2.65	620	OJ431703	55 × 3.35	220
OJ431659	38 × 3.35	400	OJ431710	60 × 3.35	210
OJ431666	40 × 2.65	570	OJ431727	65 × 3.35	190
OJ431673	40 × 3.35	350	OJ431734	70 × 3.35	170
OJ431680	45 × 3.35	320			

2kg Tub
Product Codes Begin UCALCN Product Group 5033

UC1020	30 × 2.65	660	UC1025	38 × 2.65	620
--------	-----------	-----	--------	-----------	-----

1kg Tub
Product Codes Begin UCALCN Product Group 5033

UC1000	30 × 2.65	660	UC1010	50 × 3.35	290
UC1005	38 × 2.65	620	UC1015	65 × 3.35	190

1kg Polybag
Product Codes Begin 9ALCNTQ Product Group 5035

PB379	32 × 2.65	633	PB381	50 × 3.35	278
PB380	38 × 2.65	547	PB382	65 × 3.35	216

1kg Bag
Product Codes Begin 9ALCNB Product Group 5039

OJ431529	30 × 2.65	660	OJ431567	40 × 3.35	350	OJ431604	60 × 3.35	210
OJ435831	30 × 3.35	500	OJ431574	45 × 3.35	320	OJ431611	65 × 3.35	190
OJ431536	38 × 2.65	620	OJ436159	50 × 2.65	430	OJ431628	70 × 3.35	170
OJ431543	38 × 3.35	400	OJ431581	50 × 3.35	290			
OJ431550	40 × 2.65	570	OJ431598	55 × 3.35	220			



Aluminium Tile Pegs

Aluminium – rustproof. For fixing peg tiles.

1kg Bag

Product Codes Begin **9ALTPB** Product Group **5039**

OJ431741	30mm	650
OJ431758	30mm	504

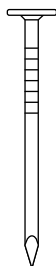

Copper Slate Nails

Copper – rustproof. For slate tiles.

25kg Clout

Product Codes Begin **9CUCNZ** Product Group **5039**

929998	30 × 2.65	608
929997	38 × 3.35	428
929996	50 × 3.35	327

1kg Polybag

Product Codes Begin **9CCNTQ** Product Group **5035**

PB377	30 × 2.65	608
PB378	38 × 2.65	520

5kg Tub

Product Codes Begin **9CUCNT** Product Group **5039**

OJ431369	30 × 2.65	608
OJ431376	30 × 3.00	570
OJ431383	30 × 3.35	542
OJ431390	32 × 2.65	580
OJ431406	32 × 3.00	550
OJ431413	32 × 3.35	500
OJ431420	35 × 3.00	510
OJ431437	38 × 2.65	520
OJ431444	38 × 3.00	490
OJ431451	38 × 3.35	428
OJ431468	40 × 3.35	410
OJ431475	50 × 3.35	327
OJ431482	60 × 3.35	290

1kg Bag

Product Codes Begin **9CUCNB** Product Group **5039**

OJ431246	30 × 2.65	608
OJ431253	30 × 3.35	542
OJ431260	32 × 2.65	580
OJ431277	32 × 3.00	550
OJ431284	32 × 3.35	500
OJ431291	35 × 3.00	510
OJ431307	38 × 2.65	520
OJ431314	38 × 3.00	490
OJ431321	38 × 3.35	428
OJ431338	40 × 3.35	410
OJ436142	50 × 2.65	364
OJ431345	50 × 3.35	327
OJ431352	60 × 3.35	290

2.5kg Tub

Product Codes Begin **UCCN** Product Group **5033**

UC1110	30 × 2.65	608
UC1115	40 × 2.65	450

1kg Clam

Product Codes Begin **UCCN** Product Group **5033**

UC1100	30 × 2.65	608
UC1105	40 × 2.65	450

1kg Tub

Product Codes Begin **9CCNNP** Product Group **5034**

UC377	30 × 2.65	608
UC378	38 × 2.65	520

500g Polybag

Product Codes Begin **9CCNTQ** Product Group **5035**

PB275	30 × 2.65	608
PB276	40 × 3.35	480



Copper Annular Ring Shank Nails

Copper - Rustproof. Strong grip with good holding power.

1kg Bag

Product Codes Begin **9CUARSN** Product Group **5039**

OJ431499	20 × 3.35	625
OJ431505	38 × 3.35	500
OJ431512	50 × 3.35	400

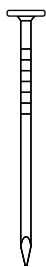

Stainless Steel Round Wire Nails

Stainless Steel – rustproof. General purpose nail. Grade 304 A2.

5kg Pack

Product Codes Begin **9STARWN** Product Group **5039**

OJ059167	40 × 2.65	542
OJ059181	50 × 2.65	441
OJ059204	65 × 3.35	216
OJ059228	75 × 3.75	145



Stainless Steel Lost Head Round Wire Nails

Stainless Steel – rustproof. Easily hidden; reduces timber deformation. Grade 304 A2.

5kg Pack

Product Codes Begin **9STALHRWN** Product Group **5039**

OJ058863	50 × 2.65	285
OJ058887	65 × 3.35	240

1kg Pack

Product Codes Begin **9STALHRWN** Product Group **5039**

OJ058870	50 × 2.65	285
OJ058894	65 × 3.35	240



Stainless Steel Annular Ring Shank Nails

Stainless Steel – rustproof. Strong grip with good holding power. Grade 304 A2.

5kg Pack

Product Codes Begin **9STAARSN** Product Group **5039**

Article No.	Approx. Count per kg Size	
OJ368214	30 × 2.65	700
OJ058528	40 × 2.65	575
OJ058566	50 × 2.65	440
OJ058580	50 × 3.0	418
OJ058627	65 × 3.35	255
OJ058641	75 × 3.75	154
OJ058665	100 × 5.0	66

1kg Pack

Product Codes Begin **9STAARSN** Product Group **5039**

OJ157924	25 × 3.35	663
OJ058535	40 × 2.65	575
OJ058573	50 × 2.70	440
OJ058634	65 × 3.35	255
OJ058658	75 × 3.75	154

500g Clam

Product Codes Begin **UCAARSS** Product Group **5033**

UC1080	25mm	765
UC1085	30mm	700
UC1090	40mm	575
UC1095	50mm	440

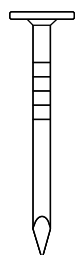

Stainless Steel Clout Nails

Stainless Steel – rustproof. For roofing, partitions and ceilings. Grade 304 A2.

5kg Pack

Product Codes Begin **9STACN** Product Group **5039**

OJ058764	30 × 2.65	660
OJ058788	40 × 2.65	570

1kg Pack

Product Codes Begin **9STACN** Product Group **5039**

OJ058771	30 × 2.65	660
OJ058795	40 × 2.65	570



Stainless Steel Panel Pins

Stainless Steel – rustproof. For lightweight work and decorative purposes. Grade 304 A2.

10kg Pack

Product Codes Begin **9STAPP** Product Group **5039**

OJ059129	30 × 1.6	1900
OJ059143	40 × 1.6	1590

1kg Pack

Product Codes Begin **9STAPP** Product Group **5039**

OJ059136	30 × 1.6	1900
OJ059150	40 × 1.6	1590



Stainless Steel Polytop Nails

A4 Stainless Steel – rustproof. For fascias, soffits, barge boards etc. HDPE Impact resistant head.

Clam Pack

Product Codes Begin **UCPOLY** Product Group **5033**

UC1695	30mm	White	250
UC1705	40mm	White	250
UC1715	50mm	White	100
UC1725	65mm	White	100
UC1700	30mm	Black	250
UC1710	40mm	Black	250
UC1720	50mm	Black	100
UC1730	65mm	Black	100



Brass Panel Pins

500g Box

Product Codes Begin **9BPP** Product Group **5039**

Article No.	Size	Article No.	Size
OJ224526	15 × 1.4	OJ224588	30 × 1.6
OJ224540	20 × 1.4	OJ224601	40 × 1.6
OJ224564	25 × 1.6		

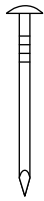

Brass Escutcheon Pins

For lightweight work and decorative purposes

500g Box

Product Codes Begin **9BEP** Product Group **5039**

OJ214640	20 × 1.6
----------	----------



Blued Fine Cut Tacks

For furniture, upholstery etc

10kg Box

Product Codes Begin **9BFCT** Product Group **5039**

OJ005012	10mm	OJ011013	20mm
OJ009010	16mm	OJ015011	25mm



Masonry Nail

For furniture, upholstery etc

Clam Pack

Product Codes Begin **UCAMN** Product Group **5033**

Article No.	Size	Box Qty	Article No.	Size	Box Qty
UC3100	25mm	100	UC3115	60mm	100
UC3105	40mm	100	UC3120	75mm	100
UC3110	50mm	100	UC3125	100mm	100



Challenge Tacks & Pins

Fine Bayonet Tacks

Challenge

Product Codes Begin **9CHABAT** Product Group **5040**

Article No.	Size	Packs per Box	Article No.	Size	Packs per Box
10204	13mm	24 × 40g	10208	20mm	24 × 40g
10206	15mm	24 × 40g	10210	25mm	24 × 40g



Challenge Tacks & Pins



Panel Pins

Challenge

Product Codes Begin **9CHAPP** Product Group **5040**

10602	13mm	24 × 30g	10610	30mm	24 × 40g
10606	20mm	24 × 50g	10612	40mm	24 × 30g
10608	25mm	24 × 50g			



Copper Hardboard Pins

Challenge

Product Codes Begin **9CHAPP** Product Group **5040**

Article No.	Size	Packs per Box
10806	20mm	24 × 40g



Veneer Pins

Challenge

Product Codes Begin **9CHAPP** Product Group **5040**

11002	15mm	24 × 30g
11004	20mm	24 × 30g
11006	25mm	24 × 30g



Netting Staples

Challenge

Product Codes Begin **9CHANS** Product Group **5040**

11202	15mm	24 × 40g
11204	20mm	24 × 40g



Gimp Pins

Challenge

Product Codes Begin **9CHAGP** Product Group **5040**

11408	13mm	24 × 30g
-------	------	----------



EB Escutcheon Pins

Challenge

Product Codes Begin **9CHAEP** Product Group **5040**

11410	15mm	24 × 40g
-------	------	----------



EB Solstuds

Challenge

Product Codes Begin **9CHAESOL** Product Group **5040**

11802	10mm	24 × 20g
-------	------	----------

Steelwork Fixings

by **lindapter**[®]

Since 1934, Lindapter has pioneered the design and manufacture of quality steelwork connection solutions. The Girder Clamp symbolises the Lindapter philosophy perfectly; boldly challenging the need to drill or weld, when a safe, high strength connection can be quickly accomplished by clamping two steel sections together.

Components of a Girder Clamp

1. Standard Grade 8 or 10 Hex Nut
2. Standard Hardened Washer
3. Lindapter Clamp
4. Packing Piece (if required)
5. Location Plate
6. Lindapter Clamp
7. Standard Grd 8.8 / 10.9 Hex Bolt or Setscrew

➔ Complete Girder Clamp assemblies supplied on request.

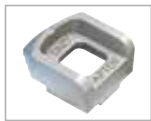
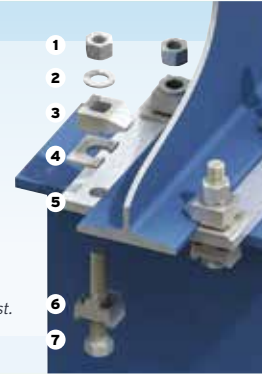

Type A Recessed Top Steelwork Fixings Short Tail

Product Codes Begin **LAS** Product Group **31**

Article No.	Size	Finish	Box Qty.						
A10S	M10	BZP	CE	1	A20S	M20	BZP	CE	1
A12S	M12	BZP	CE	1	A12SWHDG	M12	HDG		1
A16S	M16	BZP	CE	1	A16SWHDG	M16	HDG		1



Type A Recessed Top Steelwork Fixings Medium Tail

Product Codes Begin **LAM** Product Group **31**

A10M	M10	BZP	CE	1	A24M	M24	BZP	CE	1
A12M	M12	BZP	CE	1	A12MWHDG	M12	HDG		1
A16M	M16	BZP	CE	1	A16MWHDG	M16	HDG		1
A20M	M20	BZP	CE	1					

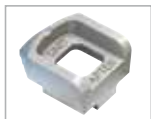

Type A Recessed Top Steelwork Fixings Long Tail

Product Codes Begin **LAL** Product Group **31**

A10L	M10	BZP	CE	1	A16L	M16	BZP	CE	1
A12L	M12	BZP	CE	1	A20L	M20	BZP	CE	1



Type B Flat Top Steelwork Fixings Short Tail

Product Codes Begin **LBS** Product Group **31**

B10S	M10	BZP	CE	1	B20S	M20	BZP	CE	1
B12S	M12	BZP	CE	1	B12SWHDG	M12	HDG		1
B16S	M16	BZP	CE	1	B16SWHDG	M16	HDG		1



Type B Flat Top Steelwork Fixings Medium Tail

Product Codes Begin **LBM** Product Group **31**

B10M	M10	BZP	CE	1	B20M	M20	BZP	CE	1
B12M	M12	BZP	CE	1	B12MWHDG	M12	HDG		1
B16M	M16	BZP	CE	1	B16MWHDG	M16	HDG		1



Type B Flat Top Steelwork Fixings Long Tail

Product Codes Begin **LBL** Product Group **31**

Article No.	Size	Finish	Box Qty.						
B10L	M10	BZP	CE	1	B20L	M20	BZP	CE	1
B12L	M12	BZP	CE	1	B12LWHDG	M12	HDG		1
B16L	M16	BZP	CE	1	B16LWHDG	M16	HDG		1



Type CW Clipped Washers for Types A & B

Product Codes Begin **LCW** Product Group **31**

Article No.	Size	Finish	Box Qty.				
CW10	M10	BZP	1	CW20	M20	BZP	1
CW12	M12	BZP	1	CW12HDG	M12	HDG	1
CW16	M16	BZP	1	CW16HDG	M16	HDG	1



Type P1/P2 Short Short Packing Pieces for Types A & B

P1

Product Codes Begin **LP** Product Group **31**

P1S08	M8	BZP	1	P1S16	M16	BZP	1	P1S12HDG	M12	HDG	1
P1S12	M12	BZP	1	P1S20	M20	BZP	1	P1S16HDG	M16	HDG	1

P2

P2S10	M10	BZP	1	P2S16	M16	BZP	1	P2S12HDG	M12	HDG	1
P2S12	M12	BZP	1	P2S20	M20	BZP	1	P2S16HDG	M16	HDG	1



Type AF High Slip Resistance Fixings Short Tail

Product Codes Begin **LAFS** Product Group **31**

AF12S	M12	HDG	1	AF20S	M20	HDG	1
AF16S	M16	HDG	1	AF24S	M24	HDG	1



Type AF High Slip Resistance Fixings Medium Tail

Product Codes Begin **LAFM** Product Group **31**

AF12M	M12	HDG	1	AF20M	M20	HDG	1
AF16M	M16	HDG	1	AF24M	M24	HDG	1



Steelwork Fixings by Lindapter

Type AFF Adjustable Clamp

Product Codes Begin **LA**AF Product Group **31**

Article No.	Size	Finish	Box Qty.
AAF12	M12	HDG	1
AAF16	M16	HDG	1
AAF20	M20	HDG	1



Type AFCW Clipped Washers for Type AF

Product Codes Begin **LA**FCW Product Group **31**

AF12CW	M12	HDG	1
AF16CW	M16	HDG	1
AF20CW	M20	HDG	1



Type AFP1/AFP2 Packing Pieces for Type AF

Product Codes Begin **LA**F Product Group **31**

AFP1

Article No.	Size	Finish	Box Qty.
AF12P1	M12	HDG	1
AF16P1	M16	HDG	1
AF20P1	M20	HDG	1
AF24P1	M24	HDG	1

AFP2

AF12P2	M12	HDG	1
AF16P2	M16	HDG	1
AF20P2	M20	HDG	1
AF24P2	M24	HDG	1



Type AFW Washers for Type AF

Product Codes Begin **LA**FW Product Group **31**

AFW12	M12	HDG	1
AFW16	M16	HDG	1
AFW20	M20	HDG	1
AFW24	M24	HDG	1



Type CF High Slip Resistance Hook Clamps

Product Codes Begin **LC**F Product Group **31**

CF12	M12	HDG	1
CF16	M16	HDG	1
CF20	M20	HDG	1



Type D2 Adjustable Steelwork Clamps with Recessed Top

Product Codes Begin **LD**2 Product Group **31**

D210	M10	BZP	1
D212	M12	BZP	1
D216	M16	BZP	1
D220	M20	BZP	1



Type LR Self Adjusting Clamp c/w Saddle Washer

Product Codes Begin **LLR** Product Group **31**

Article No.	Size	Finish	Box Qty.				
LR10	M10	BZP	1	LR16	M16	BZP	1
LR12	M12	BZP	1	LR20	M20	BZP	1



Type P1 Long Packing Pieces for Type LR

Product Codes Begin **LP1L** Product Group **31**

P1L12	M12	BZP	1	P1L16	M16	BZP	1
-------	-----	-----	---	-------	-----	-----	---



Type BR Fixings for Steel Beams or Rails Short Tail

Product Codes Begin **LBRS** Product Group **31**

BR16S	M16	BZP	1
-------	-----	-----	---



Type LS Lindapter

Product Codes Begin **LLS** Product Group **31**

LS10	M10	S/S	1
LS12	M12	S/S	1
LS16	M16	S/S	1



Type BR Fixings for Steel Beams or Rails Medium Tail

Product Codes Begin **LBRM** Product Group **31**

BR12M	M12	BZP	1
BR16M	M16	BZP	1



Type F9 Flange Clamps for Parallel Running Steel Sections

Product Codes Begin **LF9** Product Group **31**

F910NC	M10	BZP	1	F916NC	M16	BZP	1
F912NC	M12	BZP	1	F920NC	M20	BZP	1



Flush Clamp

Product Codes Begin **LFC** Product Group **31**

FC16	M12	BZP	1
------	-----	-----	---

Cavity Fixings

by **lindapter**

The CE marked range consists of the best-selling Holo-Bolt® and Lindibolt®, creating simple, cost-effective connections of SHS and other hollow sections, or conventional steelwork where access is available from one side only. The Holo-Bolt can be used as a primary structural connection as detailed in the SCI/BCSA publication 'Joints in Steel Construction - Simple Connections'.

Holo-Bolt®

Install in 3 easy steps:

1. Align pre-drilled fixture and section and insert Holo-Bolt.
2. Grip the Holo-Bolt collar with an open ended spanner.
3. Using a torque wrench, tighten the central bolt to recommended torque.



Type HB Holo-Bolt®

* HDG available upon request

Article No.	Size	Finish	Box Qty.	
HB08 1	M8	CE	BZP*	1
HB08 2	M8	CE	BZP*	1
HB08 3	M8	CE	BZP*	1
HB10 1	M10	CE	BZP*	1
HB10 2	M10	CE	BZP*	1
HB12 1	M12	CE	BZP*	1
HB12 2	M12	CE	BZP*	1
HB16 1	M16	CE	BZP*	1
HB16 2	M16	CE	BZP*	1
HB20 1	M20	CE	BZP*	1

Product Codes Begin **LHB** Product Group **31**

HB20 2	M20	CE	BZP*	1
HBCSK08 1	M8	CE	BZP*	1
HBCSK10 1	M10	CE	BZP*	1
HBCSK12 1	M12	CE	BZP*	1
HBCSK16 1	M16	CE	BZP*	1
HBST08 1	M8	CE	SS316	1
HBST10 1	M10	CE	SS316	1
HBST12 1	M12	CE	SS316	1
HBST20 1	M20	CE	SS316	1



Flushfit HB Holo-Bolt®

Product Codes Begin **LHBF** Product Group **31**

HBFF08-1	M8	BZP	1
HBFF10-1	M10	BZP	1
HBFF12-1	M12	BZP	1

HBFF08-2	M8	BZP	1
HBFF10-2	M10	BZP	1
HBFF12-2	M12	BZP	1



Flushfit HB Holo-Bolt® Tool

Product Codes Begin **LHBF** Product Group **31**

HBFF08KEY	M8	BZP	1
HBFF10KEY	M10	BZP	1

HBFF12KEY	M12	BZP	1
-----------	-----	-----	---



Type LB Lindibolt®

Product Codes Begin **LLB** Product Group **31**

LB10	M10	CE	BZP	1
LB12	M12	CE	BZP	1
LB16	M16	CE	BZP	1
LB20	M20	CE	BZP	1



Decking Fixings

by **lindapter**[®]

Lindapter produce a range of high quality, cost effective building services connections designed to fit inside the dovetail shaped re-entrant channel of decking profiles. Lindapter's fixings are compatible with various steel decking profiles from the major manufacturers including Hare Decking (formerly Richard Lees[®]), CMF[®], Kingspan[®], Tata Steel[®] and SMD[®].

Compatible Decking Profiles

Ribdeck[®] AL, E60 & 80
Use Type AW

Metfloor[®] 60 & 80
Use Type MF

Multideck[®] 60 & 80
Use Type MW2

TR60/60+ & TR80/80+
Use Type TR60

**R51, ComFlor[®] 51, Holorib[®], Superib[®],
Multideck[®] 50 & Metfloor[®] 55**
Use Type VN



Type AW Alphawedges

Product Codes Begin **LAW** Product Group **31**

Article No.	Size	Finish	Box Qty.
AW06	M10	Pre-galvanised strip & BZP wedge	1
AW08	M12	Pre-galvanised strip & BZP wedge	1
AW10	M16	Pre-galvanised strip & BZP wedge	1



MF Metfloor Connections

Product Codes Begin **LMF** Product Group **31**

MF06	M6	BZP	1
MF08	M8	BZP	1
MF10	M10	BZP	1



Type MW2 Multiwedges

Product Codes Begin **LMW** Product Group **31**

MW206	M6	Pre-galvanised strip & BZP wedge	1
MW208	M8	Pre-galvanised strip & BZP wedge	1
MW210	M10	Pre-galvanised strip & BZP wedge	1



Type TR60 TR60/TR80 Connections

Product Codes Begin **LTR60** Product Group **31**

TR6006	M6	Pre-galvanised strip & BZP wedge	1
TR6008	M8	Pre-galvanised strip & BZP wedge	1
TR6010	M10	Pre-galvanised strip & BZP wedge	1



Type VN V Nuts

Product Codes Begin **LVN** Product Group **31**

VN10	M10	BZP	1
------	-----	-----	---



Type TC Toggle Clamps

Product Codes Begin **LTC** Product Group **31**

TC08	M8	BZP	1	TC10	M10	BZP	1
------	----	-----	---	------	-----	-----	---

Support Fixings

by **lindapter**[®]

Lindapter provides easy-to-install solutions for supporting building services from structural or secondary beams, including: the suspension of HVAC equipment, pipe work, fire protection/sprinkler systems, suspended ceilings and electrical equipment.

Advantages

- Wide product range for various i-beams & perlines
- No drilling or welding
- Fast, simple installation
- No damage to steelwork
- Adjustable and removable

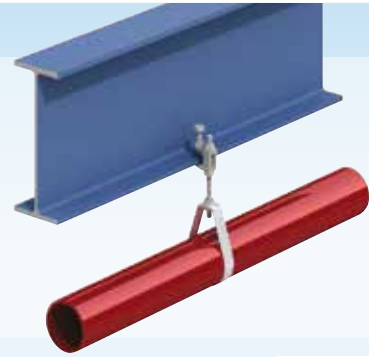

Type FLS Swivel Clamp

Article No.	Size	Finish	Box Qty.
FLS08	M8	BZP	1
FLS10	M10	BZP	1

Product Codes Begin **LFLS** Product Group **31**

Type LC Lindiclip

LC06	M6	BZP	1
LC08	M8	BZP	1

Product Codes Begin **LLC** Product Group **31**

Type FL Flange Clamps

FL108D	M8	BZP	1	FL312D	M12	BZP	1
FL108T-BOX	M8	BZP	1	FL312T-BOX	M12	BZP	1
FL210D	M10	BZP	1	FL410T-BOX	M10	BZP	1
FL210T-BOX	M10	BZP	1	FL412D-BOX	M12	BZP	1
FL410T-BOX	M10	BZP	1				

Product Codes Begin **LFL** Product Group **31**

Lindapter Swivel Assembly

SW10	M10	BZP	1
------	-----	-----	---

Product Codes Begin **LSW** Product Group **31**



Type F3 Flange Clamps

Product Codes Begin **LF3** Product Group **31**

Article No.	Size	Finish	Box Qty.				
F310NC HDG	M10	HDG	1	F316NC HDG	M16	HDG	1
F312NC HDG	M12	HDG	1	F320NC HDG	M20	HDG	1



Type HW Hemispherical Washers

Product Codes Begin **LHW** Product Group **31**

HW12	M12	BZP	1
HW16	M16	BZP	1



Type HC Hemispherical Cups

Product Codes Begin **LHC** Product Group **31**

HC12	M12	BZP	1
HC16	M16	BZP	1



Type Z10 Purlin Clips

Product Codes Begin **LZ** Product Group **31**

Z10	M10	BZP	1
-----	-----	-----	---



Type WF Webfix Purlin Connections

Product Codes Begin **LWF** Product Group **31**

WF10	M10	BZP	1
------	-----	-----	---

Floor Fixings

by **lindapter**[®]

It is now possible to connect steel flooring to supporting steelwork without on-site drilling or welding for a fast, low cost operation. Access to the underside of the flooring is not required, eliminating the need for costly scaffolding or elevated floors. Installation can be carried out quickly and safely from above, often by one person, significantly reducing costs.

Floorfast[®] for chequer plate floor

- Unique stepped design locks under the flange
- Vibration and shock resistant
- Can be safely removed for maintenance access

Grate-Fast[®] for open bar grating

- High strength cast body
- Lloyd's Register Type Approved for vibration resistance
- Hot dip galvanised as standard

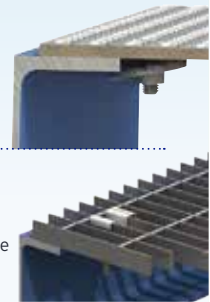

Type FF Floorfast[®] Floor Fixings

* HDG available upon request

FF08	M8	BZP	1	FF10HDG+15	3-15mm	HDG	1
FF10	M10	BZP	1	FF12HDG+10	3-15mm	HDG	1
FF12	M12	BZP*	1				

Product Codes Begin **LFF** Product Group **31**



Type GF Grate-Fast[®] Floor Fixings

GF08	M8	HDG	1
GF10HDG	M10	HDG	1

Product Codes Begin **LGF** Product Group **31**



Blindbolts

BLINDBOLT

Blindbolt Property Class 10.9 Geomet 500B

Product Codes Begin **BB** Product Group **20**

Article No.	Size	Box Qty.			
OJ046501	M8 x 50	50	OJ046570	M16 x 90	20
OJ046518	M10 x 60	40	OJ046587	M16 x 130	15
OJ046525	M10 x 95	20	OJ046594	M16 x 180	10
OJ046532	M10 x 130	20	OJ046600	M20 x 110	10
OJ046549	M12 x 70	20	OJ046648	M24 x 130	5
OJ046556	M12 x 120	25	OJ046655	M30 x 140	5
OJ046563	M12 x 180	20			



Blindbolt 8.8 Property Class Geomet 500B

Product Codes Begin **BB** Product Group **20**

OJ046709	M8 x 45	50	OJ046747	M12 x 60	20
OJ046716	M10 x 45	40	OJ046761	M16 x 60	20
OJ046723	M10 x 60	40	OJ046778	M16 x 75	20
OJ046730	M12 x 45	20			



Blindbolt Property Class 10.9 Zinc/Yellow

Product Codes Begin **BB** Product Group **20**

OJ046495	M8 x 50	50
----------	---------	----



Blindbolt Stainless Steel A4

Product Codes Begin **BB** Product Group **20**

OJ046662	M8 x 50	50
OJ046679	M10 x 60	40
OJ046686	M12 x 90	20
OJ046693	M16 x 100	20



Blindbolt Heavy Duty Stainless Steel A4

Product Codes Begin **BB** Product Group **20**

OJ046808	M8 x 45	50	OJ046846	M12 x 60	20
OJ046815	M10 x 45	40	OJ046853	M16 x 60	20
OJ046822	M10 x 60	40	OJ046860	M20 x 70	10
OJ046839	M12 x 45	20			



Scell-it Rivets

Dome Head Rivet Aluminium Body Steel Mandrel

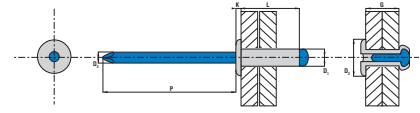
Product Codes Begin **SCASD** Product Group **55**

Article No.	Diameter x Length Size	Grip Range	Head Diameter	Head Thickness	Box Qty.
OJASD2406	2.4 x 06	2.0-4.0	5.0	0.65	2000
OJASD2408	2.4 x 08	4.0-6.0	5.0	0.65	2000
OJASD2410	2.4 x 10	6.0-8.0	5.0	0.65	2000
OJASD3206	3.2 x 06	1.5-3.5	6.5	0.8	2000
OJASD3208	3.2 x 08	3.5-5.5	6.5	0.8	2000
OJASD3210	3.2 x 10	5.5-7.0	6.5	0.8	1500
OJASD3212	3.2 x 12	7.0-9.0	6.5	0.8	1500
OJASD3214	3.2 x 14	9.0-11.0	6.5	0.8	1000
OJASD3216	3.2 x 16	11.0-13.0	6.5	0.8	1000
OJASD3218	3.2 x 18	13.0-15.0	6.5	0.8	1000
OJASD3220	3.2 x 20	15.0-17.0	6.5	0.8	1000
OJASD4006	4.0 x 06	1.0-3.0	8.0	1.0	1500
OJASD4008	4.0 x 08	3.0-5.0	8.0	1.0	1500
OJASD4010	4.0 x 10	5.0-6.5	8.0	1.0	1500
OJASD4012	4.0 x 12	6.5-8.5	8.0	1.0	1000
OJASD4014	4.0 x 14	8.5-10.5	8.0	1.0	1000
OJASD4016	4.0 x 16	10.5-12.5	8.0	1.0	1000

OJASD4018	4.0 x 18	12.5-14.5	8.0	1.0	1000
OJASD4020	4.0 x 20	14.5-16.5	8.0	1.0	500
OJASD4808	4.8 x 08	3.0-4.5	9.5	1.1	500
OJASD4810	4.8 x 10	4.5-6.0	9.5	1.1	500
OJASD4812	4.8 x 12	6.0-8.0	9.5	1.1	500
OJASD4814	4.8 x 14	8.0-10.0	9.5	1.1	500
OJASD4816	4.8 x 16	10.0-12.0	9.5	1.1	500
OJASD4818	4.8 x 18	12.0-14.0	9.5	1.1	500
OJASD4820	4.8 x 20	14.0-16.0	9.5	1.1	500
OJASD4822	4.8 x 22	16.0-18.0	9.5	1.1	500
OJASD4825	4.8 x 25	18.0-21.0	9.5	1.1	500
OJASD6412	6.4 x 12	4.0-6.0	13.0	1.8	250
OJASD6415	6.4 x 15	6.0-9.0	13.0	1.8	250
OJASD6418	6.4 x 18	9.0-13.0	13.0	1.8	250
OJASD6422	6.4 x 22	13.0-16.0	13.0	1.8	250
OJASD6426	6.4 x 26	16.0-20.0	13.0	1.8	250

Large Flange Rivet Aluminium Body Steel Mandrel

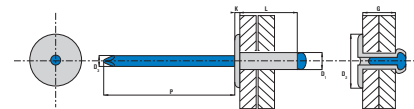
Product Codes Begin **SCASX / SCASL** Product Group **55**

Article No.	Diameter x Length Size	Grip Range	Head Diameter	Head Thickness	Box Qty.
OJASX4014	4.0 x 14	8.5-10.5	12.0	2.5	500
OJASX4016	4.0 x 16	10.5-12.5	12.0	2.5	500
OJASL4810	4.8 x 10	4.5-6.0	14.0	2.5	500
OJASL4812	4.8 x 12	6.0-8.0	14.0	2.5	500
OJASL4814	4.8 x 14	8.0-10.0	14.0	2.5	500
OJASL4816	4.8 x 16	10.0-12.0	14.0	2.5	500
OJASL4818	4.8 x 18	12.0-14.0	14.0	2.5	250
OJASL4820	4.8 x 20	14.0-16.0	14.0	2.5	250
OJASL4825	4.8 x 25	18.0-21.0	14.0	2.5	250
OJASL4830	4.8 x 30	23.0-25.0	14.0	2.5	250



Countersunk Rivet Aluminium Body Steel Mandrel

Product Codes Begin **SCASK** Product Group **55**

Article No.	Diameter x Length Size	Grip Range	Head Diameter	Head Thickness	Box Qty.
OJASK3206	3.2 x 06	1.5-3.5	6.0	0.9	2000
OJASK3208	3.2 x 08	3.5-5.0	6.0	0.9	2000
OJASK3210	3.2 x 10	5.0-7.0	6.0	0.9	1500
OJASK3212	3.2 x 12	7.0-9.0	6.0	0.9	1500
OJASK3214	3.2 x 14	9.0-10.5	6.0	0.9	1000
OJASK3216	3.2 x 16	10.5-13.0	6.0	0.9	1000
OJASK4008	4.0 x 08	3.0-5.0	7.5	1.0	1500
OJASK4010	4.0 x 10	5.0-6.5	7.5	1.0	1500
OJASK4012	4.0 x 12	6.5-8.5	7.5	1.0	1000

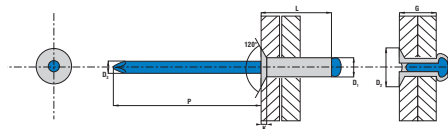

OJASK4014	4.0 x 14	8.0-10.0	7.5	1.0	1000
OJASK4808	4.8 x 08	2.0-4.5	9.0	1.2	500
OJASK4810	4.8 x 10	4.5-6.0	9.0	1.2	500
OJASK4812	4.8 x 12	6.0-8.0	9.0	1.2	500
OJASK4814	4.8 x 14	8.0-10.0	9.0	1.2	500
OJASK4816	4.8 x 16	10.0-12.0	9.0	1.2	500
OJASK4818	4.8 x 18	12.0-14.0	9.0	1.2	500
OJASK4820	4.8 x 20	14.0-16.0	9.0	1.2	500



Dome Multigrip Rivet Aluminium Body Steel Mandrel

Product Codes Begin **SCADM** Product Group **55**

Article No.	Diameter x Length Size	Grip Range	Head Diameter	Head Thickness	Box Qty.
OJUD3208	3.2 x 08	4.0-5.0	6.0	1.4	2000
OJUD3212	3.2 x 12	4.5-9.0	6.0	1.4	1500
OJUD4010	4.0 x 10	1.5-6.5	8.0	1.7	1500
OJUD4014	4.0 x 14	5.0-10.0	8.0	1.7	1000
OJUD4810	4.8 x 10	1.0-6.0	9.5	2.0	500
OJUD4815	4.8 x 15	5.0-10.5	9.5	2.0	500
OJUD4817	4.8 x 17	7.0-12.0	9.5	2.0	500
OJUD4825	4.8 x 25	12.5-20.0	9.5	2.0	500

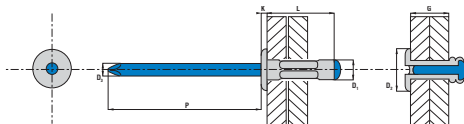

UD3208 BAG	3.2 x 08	4.0-5.0	6.0	1.4	100
UD3212 BAG	3.2 x 12	4.5-9.0	6.0	1.4	100
UD4010 BAG	4.0 x 10	1.5-6.5	8.0	1.7	50
UD4012 BAG	4.0 x 12		8.0	1.7	50
UD4810 BAG	4.8 x 10	1.0-6.0	9.5	2.0	25
UD4815 BAG	4.8 x 15	5.0-10.5	9.5	2.0	25
UD4817 BAG	4.8 x 17	7.0-12.0	9.5	2.0	25
UD4825 BAG	4.8 x 25	12.5-20.0	9.5	2.0	25



Large Flange Multigrip Rivet Aluminium Body Steel Mandrel

Product Codes Begin **SCASFM** Product Group **55**

Article No.	Diameter x Length Size	Grip Range	Head Diameter	Head Thickness	Box Qty.
OJUX4810	4.8 X 10	1.0-6.0	16.0	2.5	500
OJUX4816	4.8 X 16	6.0-12.5	16.0	2.5	250
OJUX4825	4.8 X 25	12.5-21.0	16.0	2.5	250

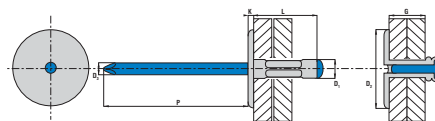

UX4810-BAG	4.8 X 10	1.0-6.0	16.0	2.5	25
UX4816-BAG	4.8 X 16	6.0-12.5	16.0	2.5	25
UX4825-BAG	4.8 X 25	12.5-21.0	16.0	2.5	25



Dome Peel Rivet Aluminium Body Steel Mandrel

Product Codes Begin **SCASDP** Product Group **55**

Article No.	Diameter x Length Size	Grip Range	Head Diameter	Head Thickness	Box Qty.
OJPAD4812	4.8 X 12	2.0-6.0	9.5	1.5	500
OJPAD4814	4.8 X 14	4.0-8.0	9.5	1.5	500
OJPAD4816	4.8 X 16	6.0-10.0	9.5	1.5	500
OJPAD4818	4.8 X 18	8.0-12.0	9.5	1.5	500
OJPAD4820	4.8 X 20	10.0-14.0	9.5	1.5	500
OJPAD4825	4.8 X 25	16.0-19.0	9.5	1.5	500

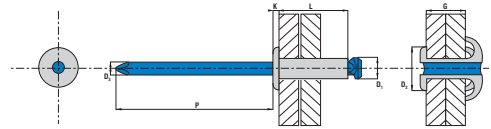

Dome Sealed Rivet Aluminium Body Steel Mandrel

Product Codes Begin **SCASDS** Product Group **55**

Article No.	Diameter x Length Size	Grip Range	Head Diameter	Head Thickness	Box Qty.
OJWAD3208	3.2 X 08	2.0-3.5	6.0	1.4	2000
OJWAD3210	3.2 X 9.5	3.5-6.5	6.0	1.4	1500
OJWAD3212	3.2 X 12	6.5-8.0	6.0	1.4	1500
OJWAD4008	4.0 X 08	0.5-3.5	8.0	1.7	1500
OJWAD4010	4.0 X 9.5	3.5-4.5	8.0	1.7	1500
OJWAD4011	4.0 X 11	4.5-6.5	8.0	1.7	1000
OJWAD4012	4.0 X 12	6.5-8.0	8.0	1.7	1000
OJWAD4808	4.8 X 08	1.0-3.0	9.5	2.0	500

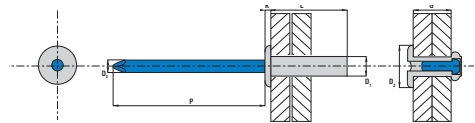

OJWAD4810	4.8 X 10	3.0-4.5	9.5	2.0	500
OJWAD4812	4.8 X 12	6.0-7.5	9.5	2.0	500
OJWAD4814	4.8 X 14	7.5-9.0	9.5	2.0	500
OJWAD4816	4.8 X 16	9.0-11.0	9.5	2.0	500
OJWAD4818	4.8 X 18	11.0-13.0	9.5	2.0	500
OJWAD4821	4.8 X 21	13.0-16.0	9.5	2.0	500



Dome Rivet Stainless Steel A2 Body Stainless Steel A2 Mandrel

Product Codes Begin **SCSSD** Product Group **55**

Article No.	Diameter x Length Size	Grip Range	Head Diameter	Head Thickness	Box Qty.
OJBTD3206	3.2 X 06	1.0-3.0	6.5	0.8	2000
OJBTD3208	3.2 X 08	3.0-5.0	6.5	0.8	2000
OJBTD3210	3.2 X 10	5.0-7.0	6.5	0.8	1500
OJBTD3212	3.2 X 12	7.0-9.0	6.5	0.8	1500
OJBTD3215	3.2 X 15	9.0-12.0	6.5	0.8	1000
OJBTD4008	4.0 X 08	2.5-4.5	8.0	1.0	1500
OJBTD4010	4.0 X 10	4.5-6.5	8.0	1.0	1500
OJBTD4012	4.0 X 12	6.5-9.5	8.0	1.0	1000

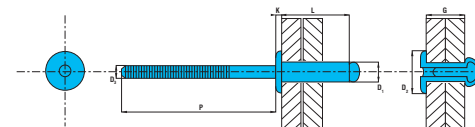

OJBTD4014	4.0 X 14	8.0-10.0	8.0	1.0	1000
OJBTD4808	4.8 X 08	1.5-4.0	9.5	1.1	500
OJBTD4810	4.8 X 10	4.0-6.0	9.5	1.1	500
OJBTD4812	4.8 X 12	6.0-8.0	9.5	1.1	500
OJBTD4814	4.8 X 14	8.0-9.5	9.5	1.1	500
OJBTD4816	4.8 X 16	9.5-11.0	9.5	1.1	500
OJBTD4818	4.8 X 18	11.0-13.0	9.5	1.1	500



Dome Rivet Steel Body Steel Mandrel

Product Codes Begin **SCSD** Product Group **55**

Article No.	Diameter x Length Size	Grip Range	Head Diameter	Head Thickness	Box Qty.
OJSD3206	3.2 X 06	1.5-3.0	6.5	0.8	2000
OJSD3208	3.2 X 08	3.0-5.0	6.5	0.8	2000
OJSD3210	3.2 X 10	5.0-7.0	6.5	0.8	1500
OJSD3212	3.2 X 12	7.0-9.0	6.5	0.8	1500
OJSD3214	3.2 X 14	9.0-11.0	6.5	0.8	1000
OJSD3216	3.2 X 16	11.0-13.0	6.5	0.8	1000
OJSD4008	4.0 X 08	2.5-4.5	8.0	1.0	1500
OJSD4010	4.0 X 10	4.5-6.5	8.0	1.0	1500
OJSD4012	4.0 X 12	6.5-8.5	8.0	1.0	1000
OJSD4014	4.0 X 14	8.5-10.5	8.0	1.0	1000

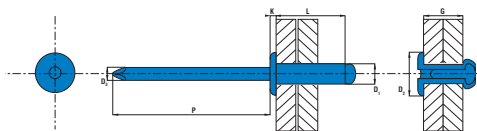

OJSD4016	4.0 X 16	10.5-12.5	8.0	1.0	1000
OJSD4018	4.0 X 18	12.5-14.5	8.0	1.0	1000
OJSD4808	4.8 X 08	2.5-4.5	9.5	1.1	500
OJSD4810	4.8 X 10	4.5-6.0	9.5	1.1	500
OJSD4812	4.8 X 12	6.0-8.0	9.5	1.1	500
OJSD4814	4.8 X 14	8.0-10.0	9.5	1.1	500
OJSD4816	4.8 X 16	10.0-11.5	9.5	1.1	500
OJSD4818	4.8 X 18	11.5-13.5	9.5	1.1	500
OJSD4820	4.8 X 20	15.0-15.0	9.5	1.1	500



Countersunk Rivet Steel Body Steel Mandrel

Product Codes Begin **SCSK** Product Group **55**

Article No.	Diameter x Length Size	Grip Range	Head Diameter	Head Thickness	Box Qty.
OJSK4810	4.8 X 10	4.0-6.0	9.0	1.2	500
OJSK4812	4.8 X 12	6.0-8.0	9.0	1.2	500
OJSK4814	4.8 X 14	8.0-10.0	9.0	1.2	500

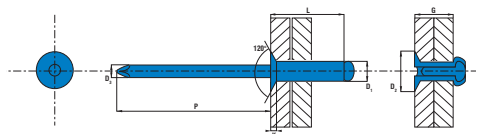



Flange Rivetnut Aluminium

Product Codes Begin **SCARNFH** Product Group **55**

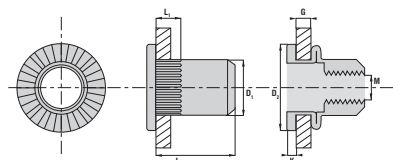
Article No.	Size	D1	D2	K	L	L1	G	Box Qty.
OJEAD0430	M4	5.9	9.0	1.0	10.0	4.0	0.3-3.0	1000
OJEAD0530	M5	6.9	10.0	1.0	12.0	4.0	0.3-3.0	1000
OJEAD0630	M6	8.9	13.0	1.5	14.5	4.0	0.5-3.0	1000
OJEAD0830	M8	10.9	16.0	1.5	16.0	4.0	0.5-3.0	500

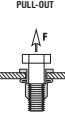
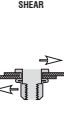

Size	DRILLING	RECOMMENDED MAX TORQUE	PULL-OUT	SHEAR
M (mm)				
	(mm)	(Nm)	(N)	(N)
M4	6.0	4.0	2 800	1 000
M5	7.0	5.0	4 900	1 100
M6	9.0	11.3	9 200	2 200
M8	11.0	14.5	14 000	2 400



Flange Rivetnut Steel

Product Codes Begin **SCSRNFH** Product Group **55**

Article No.	Size	D1	D2	K	L	L1	G	Box Qty.
OJTCD0430	M4	5.9	9.0	1.0	10.0	4.0	0.3-3.0	1000
OJTCD0530	M5	6.9	10.0	1.0	12.0	4.0	0.3-3.0	1000
OJTCD0630	M6	8.9	13.0	1.5	14.5	4.0	0.5-3.0	1000
OJTCD0830	M8	10.9	16.0	1.5	16.0	4.0	0.5-3.0	500
OJTCD1030	M10	12.9	19.0	2.0	17.0	4.0	0.5-3.0	250

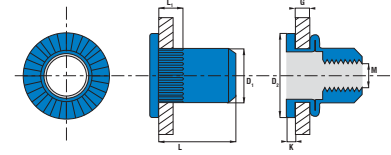

Size	DRILLING	RECOMMENDED MAX TORQUE	PULL-OUT	SHEAR
M (mm)	(mm)	(Nm)	(N)	(N)
M4	6.0	4.5	5 000	1 700
M5	7.0	5.4	11 300	2 800
M6	9.0	19.8	18 000	3 500
M8	11.0	29.0	28 000	4 500
M10	13.0	32.0	29 000	5 000



Reduced Head Rivetnut Steel

Product Codes Begin **SCSRNH** Product Group **55**

Article No.	Size	D1	D2	K	L	L1	G	Box Qty.
OJTCR0430	M4	5.9	7.0	0.6	10.0	4.0	0.5-3.0	1000
OJTCR0530	M5	6.9	8.0	0.6	11.5	4.0	0.5-3.0	1000
OJTCR0630	M6	8.9	10.0	0.6	14.0	4.0	0.5-3.0	1000
OJTCR0830	M8	10.9	12.0	0.6	15.5	4.0	0.5-3.0	500
OJTCR1035	M10	12.9	13.5	0.6	19.5	4.5	0.8-3.5	250

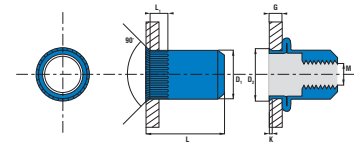

Size	DRILLING	RECOMMENDED MAX TORQUE	PULL-OUT	SHEAR
M (mm)	(mm)	(Nm)	(N)	(N)
M4	6.0	4.0	6 600	1 600
M5	7.0	5.0	9 200	2 200
M6	9.0	15.0	17 000	2 400
M8	11.0	18.0	22 000	2 900
M10	13.0	30.0	32 400	4 300



Countersunk Rivetnut Steel

Product Codes Begin **SCSRNCH** Product Group **55**

Article No.	Size	D1	D2	K	L	L1	G	Box Qty.
OJTCK0435	M4	5.9	9.0	1.5	11.5	4.5	1.5-3.5	1000
OJTCK0540	M5	6.9	10.0	1.5	13.5	5.0	1.5-4.0	1000
OJTCK0645	M6	8.9	12.0	1.5	16.0	5.5	1.5-4.5	1000
OJTCK0845	M8	10.9	14.0	1.5	19.0	5.5	1.5-4.5	500
OJTCK1045	M10	12.9	15.0	1.5	21.0	5.5	1.5-4.5	250

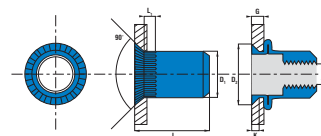

Size	DRILLING	RECOMMENDED MAX TORQUE	PULL-OUT	SHEAR
	M (mm)	(mm)	(Nm)	(N)
M4	6.0	4.0	6 600	1 600
M5	7.0	5.0	9 200	2 200
M6	9.0	15.0	17 000	2 400
M8	11.0	18.0	22 000	2 900
M10	13.0	30.0	32 400	4 300



Riveting Hand Plier

Product Codes Begin **SCSTE** Product Group **55**

Article No.	Box Qty.
E500RH	1



Rivetnut Setting Tool

Product Codes Begin **SCSTN** Product Group **55**

Article No.	Size	Box Qty.
N200	M3-M8	1



Rivet Setting Tool

Product Codes Begin **SCSTR** Product Group **55**

Article No.	Size	Box Qty.
R200	2.4-5.0	1

Kit-MASTER

FASTENERS, FIXINGS, & ACCESSORIES

Kit-MASTER – Assorted Kits

Self Tapping Screw Kits

Product Codes Begin **KM** Product Group **500**



A



B



C



D



E

Article No.

Description

Article No.	Description	
105102	Recessed Pan AB S/Tapping Screws 4-10g BZP	A
105104	Recessed Pan AB S/Tapping Screws 8-12g BZP	B
105105	Recessed Flange AB S/Tapping 6-10g Blk Phos	C
105107	Recessed Csk AB S/Tapping Screws 6-10g BZP	D
105225	Recessed Pan AB S/Tapping Screws 4-14g BZP	E

Woodscrew Kits

Product Codes Begin **KM** Product Group **500**



A



B

105138	Recessed Csk GP Woodscrews 3-6mm ZYP	A
105139	Recessed Csk T/Thread Woodscrews 4-12g BZP	B



Bolting, Nut & Washer Kits

Product Codes Begin **KM** Product Group **500**



A



B

105111	Slt'd Pan MT Screws & Nuts 2-6BA SC / BZP	A
105122	Slt'd Pan MT Screws & Nuts M3-M5 ZYP	B
105125	Form A Flat Washers M5-M16 BZP / ZYP	C
105128	Spring Washers M5-M16 ZYP	D
105130	Repair Washers 3/16"-3/8" BZP	E
105131	Red Fibre Washers 13/64"-49/64"	F
105179	Sets/Nut/Washers M5-M10 St St	G
105192	M6 HT Sets & Nuts Lgths 16-50mm ZYP	H
105193	M8 HT Sets & Nuts Lgths 16-60mm BZP / ZYP	I
105194	M10 HT Sets & Nuts Lgths 25-50mm BZP / ZYP	J
105195	Serrated Flange Nuts M5-M12 BZP	K
105219	HT Setscrews M6-M12 ZYP	L
105220	Fullnuts M6-M12 ZYP	M



C



E



G



I



D



F



H



J



K



L



M

Kit-MASTER

FASTENERS, FIXINGS, & ACCESSORIES



Acme Screws, J & U Nut Kits

Product Codes Begin **KM** Product Group **500**

105109	J & U Nuts 6-14 BZP / ZYP	A
105123	Acme Screws & J Nuts 8-14 ZYP	B



Hose Clips Kits

Product Codes Begin **KM** Product Group **500**

105184	Assorted Hose Clips
--------	---------------------



Split Pin, Clevis Pin and Spring Roll Pin Kits

Product Codes Begin **KM** Product Group **500**

105134	Split Pins 1/16"-5/32" BZP	A
105137	Split Pins 1/8"-5/16" BZP	B
105140	Split Pins M1.6-M5 BZP	C
105135	Clevis Pins 3/16"-3/8" & M6 BZP	D
105136	Spring Roll Pins M2.5-M8 SC	E





A

Circlip Kits

Product Codes Begin **KM** Product Group **500**

105141	Int. & Ext. Circlips M12-M25 SC	A
105249	External Circlips M12-M25	B
105252	Internal Circlips M12-M25	C



B



C



A

Compression & Expansion Spring Kits

Product Codes Begin **KM** Product Group **500**

105146	Compression & Expansion Springs BZP	A
105148	Compression Springs BZP	B
105112	Expansion Springs BZP	C



B



C



Speed Fastener Kits

Product Codes Begin **KM** Product Group **500**

105108	Speed Fasteners M3-M8 ZYP
--------	---------------------------

Kit-MASTER

FASTENERS, FIXINGS, & ACCESSORIES



Aluminium Blind Rivets & BZP Washers

105166 | Aluminium Blind Rivets & BZP Washers 1/8-3/16

Product Codes Begin **KM** Product Group **500**



Assorted Socket Screws

105216 | Assorted Socket Screws M5-M10

Product Codes Begin **KM** Product Group **500**



Display Counter

105201 | Display Rack for 10 Kits

Product Codes Begin **KM** Product Group **500**



Kit-Master General Purpose Woodscrew Case

OJ277813 | Kit-MASTER Case of 1,700 Chipboard Screws

Product Codes Begin **KM** Product Group **500**



Kit-MASTER

FASTENERS, FIXINGS, & ACCESSORIES



ACME SCREWS 

BLIND RIFTS

CIRCULARS

Internal, and External

HIGH TENSILE BUSHES 

I AND O NUTS

MACHINE SCREWS

NUTS

Flat, and Standard Range

PINS

Clock, Split, and Spring Ball

SELF TAPPING 

Flat Pan, and Range

SPEED FASTENERS

SPRINGS

Expansion, and Compression

WASHERS

Form A, Spring, Slotted, and Other

WOODSCREWS

Flat Groove, Round, and Round Point

Buy 9 kits, and receive a **FREE** stand, header board, and a box of generic **Kit-MASTER** brochures.



FASTENERS & FIXINGS

Stainless Steel Range of Fasteners

Countersunk Head Recessed Chipboard Screw

A2-304

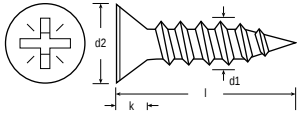

	d1	3.5mm	4.0mm	5.0mm	6.0mm
d2	max.	7	8	10	12
k	max.	2.1	2.5	3	3.6
Recess no.		2	2	2	3

Product Codes Begin [Q2021CH](#)

Size				
3.5mm x 16	4.0mm x 30	4.0mm x 80	5.0mm x 90	6.0mm x 80
3.5mm x 20	4.0mm x 35	5.0mm x 30	5.0mm x 100	6.0mm x 90
3.5mm x 25	4.0mm x 40	5.0mm x 40	6.0mm x 30	6.0mm x 100
3.5mm x 30	4.0mm x 45	5.0mm x 50	6.0mm x 40	
3.5mm x 40	4.0mm x 50	5.0mm x 60	6.0mm x 50	
4.0mm x 20	4.0mm x 60	5.0mm x 70	6.0mm x 60	
4.0mm x 25	4.0mm x 70	5.0mm x 80	6.0mm x 70	

Note: Boxes of 200 available, please see page 5.

Pan Head Recessed Chipboard Screw

A2-304

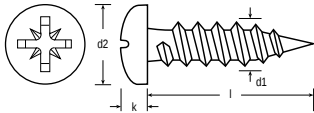

	d1	4.0mm	5.0mm	6.0mm
d2	max.	8	10	12
k	max.	2.92	3.65	4.25
Recess no.		2	2	3

Product Codes Begin [Q2022CH](#)

4.0mm x 25	5.0mm x 40
4.0mm x 30	5.0mm x 70
4.0mm x 40	
5.0mm x 30	

Our Stainless Steel range is constantly being reviewed for additional products and we also offer a comprehensive range of A4 Stainless Steel Fasteners. Please contact your local sales office for further details.



Countersunk Head Recessed Woodscrew

DIN 7997 A2-304

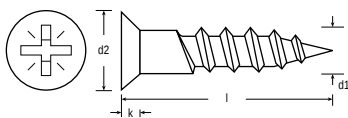

	(No. 4)	(No. 6)	(No. 8)	(No. 10)	(No. 12)
d1	3.0mm	3.5mm	4.0mm	5.0mm	5.5mm
d2	5.6	6.5	7.5	9.2	10.2
k	1.65	1.13	2.2	2.5	2.75
Recess no.	1	2	2	2	3

Product Codes Begin **Q207997**

Size							
3.0 × 16	3.5 × 16	3.5 × 40	4.0 × 40	5.0 × 25	5.0 × 65	5.5 × 40	5.5 × 100
3.0 × 20	3.5 × 20	4.0 × 20	4.0 × 50	5.0 × 30	5.0 × 75	5.5 × 50	
3.0 × 25	3.5 × 25	4.0 × 25	4.0 × 65	5.0 × 40	5.0 × 100	5.5 × 65	
3.5 × 13	3.5 × 30	4.0 × 30	5.0 × 20	5.0 × 50	5.5 × 30	5.5 × 75	

Round Head Recessed Woodscrew

DIN 7996 A2-304

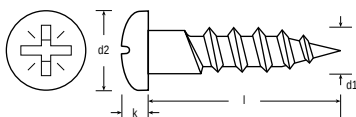

	(No. 4)	(No. 6)	(No. 8)	(No. 10)	(No. 12)
d1	3.0mm	3.5mm	4.0mm	5.0mm	5.5mm
d2	6	7	8	10	11
k	2.1	2.35	2.8	3.5	3.8
Recess no.	1	2	2	2	3

Product Codes Begin **Q207996**

3.5 × 30	4.0 × 25	4.0 × 65	5.0 × 50	5.5 × 40
4.0 × 13	4.0 × 30	5.0 × 25	5.0 × 65	5.5 × 50
4.0 × 16	4.0 × 40	5.0 × 30	5.0 × 75	5.5 × 65
4.0 × 20	4.0 × 50	5.0 × 40	5.5 × 30	5.5 × 75

Stainless Steel Range of Fasteners

Countersunk Head Slotted Woodscrews

DIN 97 A2-304

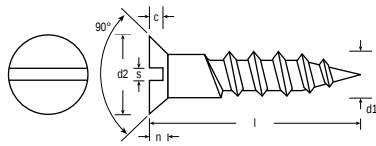

d1	3.0mm	3.5mm	4.0mm	5.0mm	5.5mm	6.0mm
d2	5.6	6.5	7.5	9.2	10.2	11.0
n max.	1.65	1.93	2.2	2.5	2.75	3.0
s	0.8	0.8	1.0	1.2	1.2	1.6
c min.	0.85	1.0	1.1	1.3	1.4	1.6

Product Codes Begin **Q20970**

Size					
3.0 × 20	3.5 × 30	4.0 × 20	4.0 × 40	5.0 × 25	5.0 × 50
3.5 × 20	3.5 × 40	4.0 × 25	4.0 × 50	5.0 × 30	5.5 × 75
3.5 × 25	4.0 × 16	4.0 × 30	4.0 × 65	5.0 × 40	5.5 × 100

Raised Head Slotted Woodscrews

DIN 95 A2-304

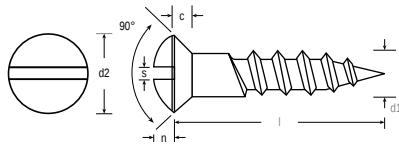

d1	3.5mm	4.0mm	5.0mm	5.5mm
d2	6.5	7.5	9.2	10.2
n max.	1.93	2.2	2.5	2.75
s	0.8	1.0	1.2	1.2
c min.	1.4	1.6	2	2.2

Product Codes Begin **Q20950**

3.5 × 20
4.0 × 40

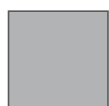

Our Stainless Steel range is constantly being reviewed for additional products and we also offer a comprehensive range of A4 Stainless Steel Fasteners. Please contact your local sales office for further details.



Countersunk Head Recessed Self Tapping Screws AB Point

DIN 7982C A2-304

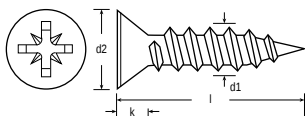

		(No. 2)	(No. 4)	(No. 6)	(No. 7)	(No. 8)	(No. 10)	(No. 12)	(No. 14)
d1		2.2mm	2.9mm	3.5mm	3.9mm	4.2mm	4.8mm	5.5mm	6.3mm
d2	max.	4.3	5.5	6.8	7.5	8.1	9.5	10.8	12.4
k	max.	1.3	1.7	2.1	2.3	2.5	3	3.4	3.8
Recess no.		1	1	2	2	2	2	3	3

Product Codes Begin **Q207982C**

Size				
2 × 1/2 (2.2 × 13)	6 × 5/8 (3.5 × 16)	8 × 1/2 (4.2 × 13)	10 × 3/4 (4.8 × 19)	12 × 1.1/2 (5.5 × 38)
4 × 1/4 (2.9 × 6.5)	6 × 3/4 (3.5 × 19)	8 × 5/8 (4.2 × 16)	10 × 1 (4.8 × 25)	12 × 1.3/4 (5.5 × 45)
4 × 5/16 (2.9 × 8)	6 × 1 (3.5 × 25)	8 × 3/4 (4.2 × 19)	10 × 1.1/4 (4.8 × 32)	12 × 2 (5.5 × 50)
4 × 3/8 (2.9 × 9.5)	6 × 1.1/4 (3.5 × 32)	8 × 1 (4.2 × 25)	10 × 1.1/2 (4.8 × 38)	14 × 1 (6.3 × 25)
4 × 1/2 (2.9 × 13)	6 × 1.1/2 (3.5 × 38)	8 × 1.1/4 (4.2 × 32)	10 × 1.3/4 (4.8 × 45)	14 × 1.1/4 (6.3 × 32)
4 × 5/8 (2.9 × 16)	6 × 2 (3.5 × 50)	8 × 1.1/2 (4.2 × 38)	10 × 2 (4.8 × 50)	14 × 1.1/2 (6.3 × 38)
4 × 3/4 (2.9 × 19)	7 × 1/2 (3.9 × 13)	8 × 1.3/4 (4.2 × 45)	10 × 2.1/2 (4.8 × 65)	14 × 2 (6.3 × 50)
4 × 1 (2.9 × 25)	7 × 1 (3.9 × 25)	8 × 2 (4.2 × 50)	12 × 5/8 (5.5 × 16)	14 × 2.1/2 (6.3 × 65)
6 × 1/4 (3.5 × 6.5)	7 × 1.1/2 (3.9 × 38)	8 × 2.1/2 (4.2 × 65)	12 × 3/4 (5.5 × 19)	
6 × 3/8 (3.5 × 9.5)	8 × 5/16 (4.2 × 8)	10 × 1/2 (4.8 × 13)	12 × 1 (5.5 × 25)	
6 × 1/2 (3.5 × 13)	8 × 3/8 (4.2 × 9.5)	10 × 5/8 (4.8 × 16)	12 × 1.1/4 (5.5 × 32)	

Pan Head Recessed Self Tapping Screws AB Point

DIN 7981C A2-304

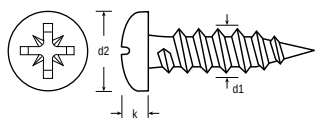

		(No. 2)	(No. 4)	(No. 6)	(No. 7)	(No. 8)	(No. 10)	(No. 12)	(No. 14)
d1		2.2mm	2.9mm	3.5mm	3.9mm	4.2mm	4.8mm	5.5mm	6.3mm
d2	max.	4.2	5.6	6.9	7.5	8.2	9.5	10.8	12.5
k	max.	1.8	2.2	2.6	2.8	3.05	3.55	3.95	4.55
Recess no.		1	1	2	2	2	2	3	3

Product Codes Begin **Q207981C**

2 × 1/4 (2.2 × 6.5)	6 × 3/8 (3.5 × 9.5)	8 × 1/2 (4.2 × 13)	10 × 5/8 (4.8 × 16)	12 × 1.1/4 (5.5 × 32)
2 × 5/16 (2.2 × 8)	6 × 1/2 (3.5 × 13)	8 × 5/8 (4.2 × 16)	10 × 3/4 (4.8 × 19)	12 × 1.1/2 (5.5 × 38)
2 × 3/8 (2.2 × 9.5)	6 × 3/4 (3.5 × 19)	8 × 3/4 (4.2 × 19)	10 × 1 (4.8 × 25)	12 × 1.3/4 (5.5 × 45)
2 × 1/2 (2.2 × 13)	6 × 1 (3.5 × 25)	8 × 7/8 (4.2 × 22)	10 × 1.1/4 (4.8 × 32)	12 × 2 (5.5 × 50)
4 × 1/4 (2.9 × 6.5)	6 × 1.1/4 (3.5 × 32)	8 × 1 (4.2 × 25)	10 × 1.1/2 (4.8 × 38)	12 × 2.1/2 (5.5 × 65)
4 × 3/8 (2.9 × 9.5)	6 × 1.1/2 (3.5 × 38)	8 × 1.1/4 (4.2 × 32)	10 × 1.3/4 (4.8 × 45)	14 × 5/8 (6.3 × 16)
4 × 1/2 (2.9 × 13)	7 × 3/8 (3.9 × 9.5)	8 × 1.1/2 (4.2 × 38)	10 × 2 (4.8 × 50)	14 × 3/4 (6.3 × 19)
4 × 5/8 (2.9 × 16)	7 × 1/2 (3.9 × 13)	8 × 1.3/4 (4.2 × 45)	10 × 2.1/2 (4.8 × 65)	14 × 1 (6.3 × 25)
4 × 3/4 (2.9 × 19)	7 × 3/4 (3.9 × 19)	8 × 2 (4.2 × 50)	12 × 1/2 (5.5 × 13)	14 × 1.1/4 (6.3 × 32)
4 × 1 (2.9 × 25)	7 × 1 (3.9 × 25)	8 × 2.1/2 (4.2 × 65)	12 × 5/8 (5.5 × 16)	14 × 1.1/2 (6.3 × 38)
6 × 1/4 (3.5 × 6.5)	8 × 1/4 (4.2 × 6.5)	10 × 3/8 (4.8 × 9.5)	12 × 3/4 (5.5 × 19)	14 × 2 (6.3 × 50)
6 × 5/16 (3.5 × 8)	8 × 3/8 (4.2 × 9.5)	10 × 1/2 (4.8 × 13)	12 × 1 (5.5 × 25)	

Stainless Steel Range of Fasteners

Raised Head Recessed Self Tapping Screws AB Point

DIN 7983C A2-304

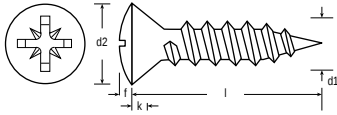

		(No. 4)	(No. 6)	(No. 8)	(No. 10)
d1		2.9mm	3.5mm	4.2mm	4.8mm
d2	max.	5.5	6.8	8.1	9.5
f		0.9	1.2	1.4	1.5
k		1.7	2.1	2.5	3.0
Recess no.		1	2	2	2

Product Codes Begin **Q207983C**

Size					
6 × 3/8	(3.5 × 9.5)	6 × 3/4	(3.5 × 19)	8 × 3/4	(4.2 × 19)
6 × 1/2	(3.5 × 13)	6 × 1	(3.5 × 25)	8 × 1	(4.2 × 25)
6 × 5/8	(3.5 × 16)	8 × 1/2	(4.2 × 13)	8 × 1.1/4	(4.2 × 32)
				8 × 1.1/2	(4.2 × 38)
				10 × 3/4	(4.8 × 19)
				10 × 1	(4.8 × 25)

Flange Head Recessed Self Tapping Screws

BS4174 A2-304

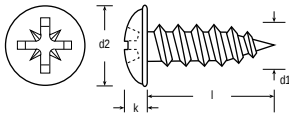

		(No. 6)	(No. 8)	(No. 10)
d1		3.5mm	4.2mm	4.8mm
d2	max.	8.15	9.75	11.38
k	max.	1.88	2.36	2.9
Recess no.		2	2	2

Product Codes Begin **Q20FLGEC**

6 × 3/8	(3.5 × 9.5)	8 × 3/8	(4.2 × 9.5)	8 × 1	(4.2 × 25)	10 × 1	(4.8 × 25)
6 × 1/2	(3.5 × 13)	8 × 1/2	(4.2 × 13)	10 × 1/2	(4.8 × 13)		
6 × 5/8	(3.5 × 16)	8 × 5/8	(4.2 × 16)	10 × 5/8	(4.8 × 16)		
6 × 3/4	(3.5 × 19)	8 × 3/4	(4.2 × 19)	10 × 3/4	(4.8 × 19)		

Our Stainless Steel range is constantly being reviewed for additional products and we also offer a comprehensive range of A4 Stainless Steel Fasteners. Please contact your local sales office for further details.



Countersunk Head Slotted Self Tapping Screws AB Point

DIN 7972C A2-304

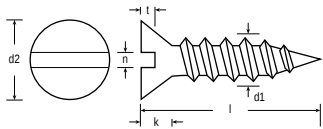

		(No. 4)	(No. 6)	(No. 8)	(No. 10)	(No. 12)
	d1	2.9mm	3.5mm	4.2mm	4.8mm	5.9mm
d2	max.	5.5	6.8	8.1	9.5	10.8
k	max.	1.7	2.1	2.5	3	3.4
n		0.8	1	1.2	1.2	1.6
t	min.	0.5	0.6	0.75	0.85	1.0

Product Codes Begin **Q207972C**

Size				
4 × 3/8 (2.9 × 9.5)	6 × 3/4 (3.5 × 19)	8 × 1 (4.2 × 25)	10 × 3/4 (4.8 × 19)	12 × 1/2 (5.5 × 13)
4 × 1/2 (2.9 × 13)	6 × 1 (3.5 × 25)	8 × 1.1/4 (4.2 × 32)	10 × 1 (4.8 × 25)	12 × 3/4 (5.5 × 19)
4 × 5/8 (2.9 × 16)	6 × 1.1/4 (3.5 × 32)	8 × 1.1/2 (4.2 × 38)	10 × 1.1/4 (4.8 × 32)	12 × 1 (5.5 × 25)
6 × 3/8 (3.5 × 9.5)	8 × 1/2 (4.2 × 13)	10 × 1/2 (4.8 × 13)	10 × 1.1/2 (4.8 × 38)	
6 × 5/8 (3.5 × 16)	8 × 3/4 (4.2 × 19)	10 × 5/8 (4.8 × 16)	10 × 2 (4.8 × 50)	

Pan Head Slotted Self Tapping Screws AB Point

DIN 7971C A2-304

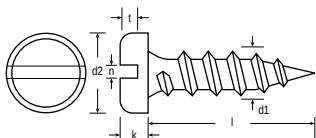

		(No. 4)	(No. 6)	(No. 8)	(No. 10)	(No. 12)	(No. 14)
	d1	2.9mm	3.5mm	4.2mm	4.8mm	5.5mm	6.3mm
d2	max.	5.6	6.9	8.2	9.5	10.8	12.5
k	max.	1.75	2.1	2.45	2.8	3.2	3.65
n		0.8	1	1.2	1.2	1.6	1.6
t	min.	0.75	0.95	1.15	1.35	1.55	1.8

Product Codes Begin **Q207971C**

Size				
4 × 3/8 (2.9 × 9.5)	6 × 1/2 (3.5 × 13)	8 × 5/8 (4.2 × 16)	10 × 1.1/2 (4.8 × 38)	14 × 5/8 (6.3 × 16)
4 × 1/2 (2.9 × 13)	6 × 3/4 (3.5 × 19)	10 × 5/8 (4.8 × 16)	10 × 2 (4.8 × 50)	14 × 1 (6.3 × 25)
4 × 3/4 (2.9 × 19)	6 × 1.1/4 (3.5 × 32)	10 × 3/4 (4.8 × 19)	12 × 5/8 (5.5 × 16)	
4 × 1 (2.9 × 25)	8 × 3/8 (4.2 × 9.5)	10 × 1 (4.8 × 25)	12 × 3/4 (5.5 × 19)	
6 × 3/8 (3.5 × 9.5)	8 × 1/2 (4.2 × 13)	10 × 1.1/4 (4.8 × 32)	12 × 1 (5.5 × 25)	

Stainless Steel Range of Fasteners

Raised Head Slotted Self Tapping Screws AB Point

DIN 7973C A2-304

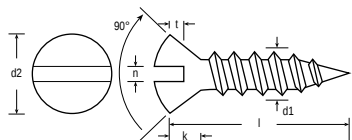

		(No. 4)	(No. 6)	(No. 8)	(No. 10)
d1		2.9mm	3.5mm	4.2mm	4.8mm
d2 max.		5.5	6.8	8.1	9.5
k max.		1.7	2.1	2.5	3
n		0.8	1	1.2	1.2
t min.		1.25	1.55	1.85	2.15

Product Codes Begin **Q207973C**

Size					
4 × 1/2	(2.9 × 13)	6 × 3/4	(3.5 × 19)	8 × 5/8	(4.2 × 16)
4 × 5/8	(2.9 × 16)	6 × 1	(3.5 × 25)	8 × 3/4	(4.2 × 19)
4 × 3/4	(2.9 × 19)	6 × 1.1/4	(3.5 × 32)	8 × 1	(4.2 × 25)
6 × 3/8	(3.5 × 9.5)	6 × 1.1/2	(3.5 × 38)	8 × 1.1/4	(4.2 × 32)
6 × 1/2	(3.5 × 13)	8 × 1/2	(4.2 × 13)	10 × 5/8	(4.8 × 16)
				10 × 3/4	(4.8 × 19)
				10 × 1	(4.8 × 25)
				10 × 1.1/4	(4.8 × 32)
				10 × 1.1/2	(4.8 × 38)

Pan Head Recessed Supertite Screws

DIN 7500C A2-304

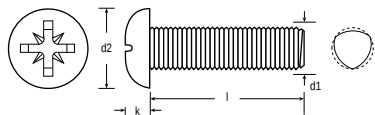

	d1	M2.5	M3	M4	M5	M6
d2 max.		5	6	8	10	12
k max.		2.12	2.52	3.25	3.95	4.75
Recess min.		1.27	1.63	1.90	2.64	3.02
Penetration max.		1.52	1.93	2.36	3.10	3.48
Recess No.		1	1	2	2	3

Product Codes Begin **Q207500C**

Size					
M2.5 × 8	M4 × 8	M4 × 20	M6 × 10	M6 × 30	
M3 × 6	M4 × 10	M5 × 12	M6 × 12		
M3 × 8	M4 × 12	M5 × 16	M6 × 16		
M4 × 6	M4 × 16	M5 × 30	M6 × 25		



Our Stainless Steel range is constantly being reviewed for additional products and we also offer a comprehensive range of A4 Stainless Steel Fasteners. Please contact your local sales office for further details.



Countersunk Head Recessed Supertite Screws

DIN 7500M A2-304

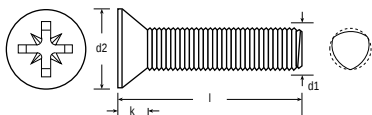

	d1	M3	M4	M5	M6
d2	max.	5.60	7.50	9.20	11.00
k	max.	1.65	2.20	2.50	3.00
Recess	min.	1.48	1.60	2.06	2.46
Penetration	max.	1.73	2.06	2.51	2.92
Recess	No.	1	2	2	3

Product Codes Begin **Q207500M**

Size	M3 × 8	M4 × 6	M4 × 12	M5 × 12	M6 × 16
	M3 × 10	M4 × 8	M5 × 10	M5 × 16	

Hexagon Bolts

DIN 931 A2-304

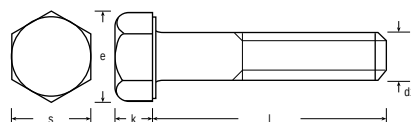

d1	M5	M6	M8	M10	M12	M14	M16	M18	M20	M22	M24	M27	M30	M33	M36
e	8.79	11.05	14.38	18.9	21.1	24.49	26.75	30.14	33.53	35.72	39.98	45.2	50.85	55.37	60.79
k	3.5	4	5.3	6.4	7.5	8.8	10	11.5	12.5	14	15	17	18.7	21	22.5
s	8	10	13	17	19	22	24	27	30	34	36	41	46	50	55

Product Codes Begin **Q20931**

M5 × 25	M6 × 130	M8 × 240	M10 × 250	M12 × 200	M16 × 65	M18 × 100	M22 × 110	M30 × 180
M5 × 30	M6 × 140	M8 × 260	M10 × 260	M12 × 220	M16 × 70	M18 × 120	M22 × 120	M33 × 240
M5 × 35	M6 × 180	M10 × 35	M10 × 270	M12 × 240	M16 × 75	M18 × 180	M22 × 160	M36 × 130
M5 × 40	M8 × 30	M10 × 40	M10 × 300	M12 × 250	M16 × 80	M20 × 60	M24 × 70	M36 × 150
M5 × 50	M8 × 35	M10 × 45	M12 × 40	M12 × 260	M16 × 90	M20 × 65	M24 × 75	M36 × 160
M5 × 60	M8 × 40	M10 × 50	M12 × 45	M12 × 270	M16 × 100	M20 × 70	M24 × 80	
M5 × 65	M8 × 45	M10 × 55	M12 × 50	M12 × 300	M16 × 110	M20 × 75	M24 × 90	
M5 × 70	M8 × 50	M10 × 60	M12 × 55	M14 × 50	M16 × 120	M20 × 80	M24 × 100	
M5 × 75	M8 × 55	M10 × 65	M12 × 60	M14 × 60	M16 × 130	M20 × 85	M24 × 110	
M5 × 80	M8 × 60	M10 × 70	M12 × 65	M14 × 65	M16 × 140	M20 × 90	M24 × 120	
M6 × 25	M8 × 65	M10 × 75	M12 × 70	M14 × 70	M16 × 150	M20 × 100	M24 × 130	
M6 × 30	M8 × 70	M10 × 80	M12 × 75	M14 × 75	M16 × 160	M20 × 110	M24 × 140	
M6 × 35	M8 × 75	M10 × 85	M12 × 80	M14 × 80	M16 × 170	M20 × 120	M24 × 150	
M6 × 40	M8 × 80	M10 × 90	M12 × 85	M14 × 100	M16 × 180	M20 × 130	M24 × 160	
M6 × 45	M8 × 90	M10 × 100	M12 × 90	M14 × 120	M16 × 190	M20 × 140	M24 × 180	
M6 × 50	M8 × 100	M10 × 110	M12 × 95	M14 × 140	M16 × 200	M20 × 150	M24 × 200	
M6 × 55	M8 × 110	M10 × 120	M12 × 100	M14 × 150	M16 × 210	M20 × 160	M27 × 100	
M6 × 60	M8 × 120	M10 × 130	M12 × 110	M14 × 160	M16 × 230	M20 × 180	M27 × 110	
M6 × 65	M8 × 130	M10 × 140	M12 × 120	M14 × 170	M16 × 250	M20 × 200	M27 × 120	
M6 × 70	M8 × 140	M10 × 150	M12 × 130	M14 × 180	M16 × 270	M20 × 220	M27 × 150	
M6 × 75	M8 × 150	M10 × 160	M12 × 140	M14 × 200	M16 × 340	M20 × 240	M30 × 90	
M6 × 80	M8 × 160	M10 × 170	M12 × 150	M16 × 45	M18 × 60	M20 × 280	M30 × 100	
M6 × 90	M8 × 170	M10 × 180	M12 × 160	M16 × 50	M18 × 70	M22 × 75	M30 × 110	
M6 × 100	M8 × 190	M10 × 200	M12 × 170	M16 × 55	M18 × 75	M22 × 80	M30 × 120	
M6 × 110	M8 × 200	M10 × 210	M12 × 180	M16 × 60	M18 × 80	M22 × 90	M30 × 130	
M6 × 120	M8 × 220	M10 × 240	M12 × 190		M18 × 90	M22 × 100	M30 × 140	

> Stainless Steel Range of Fasteners

Hexagon Set Screws Fully Threaded

DIN 933 A2-304

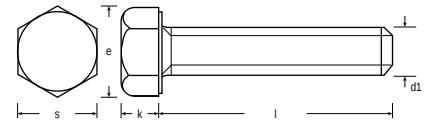

d1	M2.5	M3	M4	M5	M6	M8	M10	M12	M14	M16	M18	M20	M22	M24	M27	M30	M33	M36
e	5.45	6.01	7.66	8.79	11.05	14.38	18.9	21.1	24.49	26.75	30.14	33.53	35.72	39.98	45.2	50.85	55.37	60.79
k	1.7	2	2.8	3.5	4	5.3	6.4	7.5	8.8	10	11.5	12.5	14	15	17	18.7	21	22.5
s	5	5.5	7	8	10	13	17	19	22	24	27	30	34	36	41	46	50	55

Product Codes Begin **Q20933**

Size	M2 × 6	M4 × 60	M6 × 20	M8 × 35	M10 × 40	M12 × 65	M16 × 20	M18 × 70	M24 × 80
	M2 × 8	M4 × 70	M6 × 25	M8 × 40	M10 × 45	M12 × 70	M16 × 25	M18 × 80	M24 × 90
	M2 × 10	M4 × 80	M6 × 30	M8 × 45	M10 × 50	M12 × 75	M16 × 30	M18 × 100	M24 × 100
	M2 × 12	M5 × 6	M6 × 35	M8 × 50	M10 × 55	M12 × 80	M16 × 35	M20 × 25	M24 × 110
	M2.5 × 6	M5 × 8	M6 × 40	M8 × 55	M10 × 60	M12 × 85	M16 × 40	M20 × 30	M24 × 120
	M2.5 × 16	M5 × 10	M6 × 45	M8 × 60	M10 × 65	M12 × 90	M16 × 45	M20 × 35	M24 × 150
	M3 × 6	M5 × 12	M6 × 50	M8 × 65	M10 × 70	M12 × 95	M16 × 50	M20 × 40	M24 × 180
	M3 × 8	M5 × 14	M6 × 55	M8 × 70	M10 × 75	M12 × 100	M16 × 55	M20 × 45	M24 × 200
	M3 × 10	M5 × 16	M6 × 60	M8 × 75	M10 × 80	M12 × 110	M16 × 60	M20 × 50	M27 × 100
	M3 × 12	M5 × 18	M6 × 65	M8 × 80	M10 × 85	M12 × 120	M16 × 65	M20 × 55	M27 × 150
	M3 × 16	M5 × 20	M6 × 70	M8 × 90	M10 × 90	M12 × 130	M16 × 70	M20 × 60	M30 × 60
	M3 × 20	M5 × 22	M6 × 75	M8 × 95	M10 × 100	M12 × 140	M16 × 75	M20 × 65	M30 × 80
	M3 × 25	M5 × 25	M6 × 80	M8 × 100	M10 × 110	M12 × 150	M16 × 80	M20 × 70	M30 × 90
	M3 × 30	M5 × 30	M6 × 90	M8 × 110	M10 × 120	M12 × 160	M16 × 90	M20 × 75	M33 × 90
	M3 × 35	M5 × 35	M6 × 100	M8 × 120	M10 × 130	M12 × 180	M16 × 110	M20 × 80	M36 × 80
	M3 × 40	M5 × 40	M6 × 110	M8 × 130	M10 × 140	M12 × 200	M16 × 120	M20 × 90	M36 × 100
	M3 × 50	M5 × 45	M6 × 120	M8 × 150	M10 × 150	M14 × 20	M16 × 130	M20 × 100	
	M4 × 6	M5 × 50	M6 × 130	M8 × 170	M10 × 160	M14 × 25	M16 × 140	M20 × 110	
	M4 × 8	M5 × 55	M6 × 140	M8 × 180	M10 × 180	M14 × 30	M16 × 150	M20 × 120	
	M4 × 10	M5 × 60	M6 × 150	M8 × 190	M10 × 200	M14 × 35	M16 × 160	M20 × 130	
	M4 × 12	M5 × 65	M8 × 8	M8 × 200	M12 × 16	M14 × 40	M16 × 180	M20 × 140	
	M4 × 14	M5 × 70	M8 × 10	M10 × 10	M12 × 20	M14 × 45	M16 × 190	M20 × 150	
	M4 × 16	M5 × 75	M8 × 12	M10 × 12	M12 × 25	M14 × 50	M16 × 200	M22 × 50	
	M4 × 20	M5 × 80	M8 × 14	M10 × 14	M12 × 30	M14 × 55	M18 × 35	M24 × 40	
	M4 × 25	M5 × 100	M8 × 16	M10 × 16	M12 × 35	M14 × 60	M18 × 40	M24 × 45	
	M4 × 30	M6 × 8	M8 × 18	M10 × 20	M12 × 40	M14 × 65	M18 × 45	M24 × 50	
	M4 × 35	M6 × 10	M8 × 20	M10 × 22	M12 × 45	M14 × 70	M18 × 50	M24 × 55	
	M4 × 40	M6 × 12	M8 × 22	M10 × 25	M12 × 50	M14 × 80	M18 × 55	M24 × 60	
	M4 × 50	M6 × 14	M8 × 25	M10 × 30	M12 × 55	M14 × 90	M18 × 60	M24 × 65	
	M4 × 55	M6 × 16	M8 × 30	M10 × 35	M12 × 60	M14 × 100	M18 × 65	M24 × 70	

Our Stainless Steel range is constantly being reviewed for additional products and we also offer a comprehensive range of A4 Stainless Steel Fasteners. Please contact your local sales office for further details.



UNC Hexagon Bolts

BS1768 A2-304

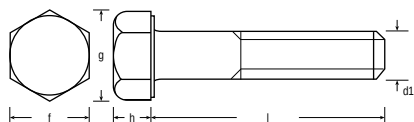

d1	1/4" UNC	5/16" UNC	3/8" UNC	1/2" UNC
f max.	0.438	0.500	0.562	0.750
g max.	0.505	0.577	0.650	0.866
h max.	0.188	0.235	0.268	0.364

Product Codes Begin [Q2017681](#)

Size					
1/4 UNC x 1	5/16 UNC x 2	3/8 UNC x 4	5/8 UNC x 2.1/4	3/4 UNC x 2.1/4	1 UNC x 6
1/4 UNC x 1.1/4	5/16 UNC x 2.1/2	1/2 UNC x 2	5/8 UNC x 2.1/2	3/4 UNC x 2.1/2	
1/4 UNC x 1.1/2	3/8 UNC x 1.1/2	1/2 UNC x 2.3/4	5/8 UNC x 2.3/4	3/4 UNC x 3	
1/4 UNC x 2.1/4	3/8 UNC x 2	1/2 UNC x 3	5/8 UNC x 3	3/4 UNC x 4.1/2	
1/4 UNC x 2.1/2	3/8 UNC x 2.1/4	1/2 UNC x 3.1/2	5/8 UNC x 3.1/2	3/4 UNC x 5	
5/16 UNC x 1.1/4	3/8 UNC x 2.1/2	1/2 UNC x 4	5/8 UNC x 4	7/8 UNC x 3	
5/16 UNC x 1.1/2	3/8 UNC x 3	5/8 UNC x 1.3/4	5/8 UNC x 4.1/2	1 UNC x 3	
5/16 UNC x 1.3/4	3/8 UNC x 3.1/2	5/8 UNC x 2	3/4 UNC x 2	1 UNC x 5	

UNC Hexagon Set Screws

BS1768 A2-304

Product Codes Begin [Q2017682](#)

Size					
1/4 UNC x 1/2	1/4 UNC x 1.1/4	5/16 UNC x 1	3/8 UNC x 3/4	3/8 UNC x 2	1/2 UNC x 1.3/4
1/4 UNC x 5/8	1/4 UNC x 2	5/16 UNC x 1.1/4	3/8 UNC x 1	1/2 UNC x 1	1/2 UNC x 2
1/4 UNC x 3/4	5/16 UNC x 1/2	5/16 UNC x 1.1/2	3/8 UNC x 1.1/4	1/2 UNC x 1.1/4	1/2 UNC x 3
1/4 UNC x 1	5/16 UNC x 3/4	5/16 UNC x 2	3/8 UNC x 1.1/2	1/2 UNC x 1.1/2	1/2 UNC x 4

Stainless Steel Range of Fasteners

Hexagon Head Coach Screws

DIN 571 A2-304

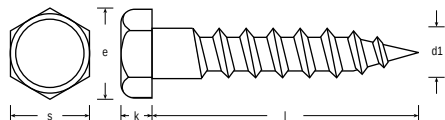

	d1	6mm	8mm	10mm	12mm
k		4	5.5	7	8
s		10	13	17	19
e min.		10.89	14.2	18.72	20.88

Product Codes Begin **Q205710**

Size	M6 × 25	M6 × 70	M8 × 40	M8 × 75	M8 × 150	M10 × 70	M10 × 120	M12 × 60	M12 × 100
	M6 × 30	M6 × 80	M8 × 50	M8 × 80	M10 × 40	M10 × 75	M10 × 130	M12 × 70	M12 × 120
	M6 × 40	M6 × 90	M8 × 60	M8 × 90	M10 × 50	M10 × 80	M10 × 140	M12 × 75	M12 × 130
	M6 × 50	M6 × 100	M8 × 65	M8 × 100	M10 × 60	M10 × 90	M10 × 150	M12 × 80	M12 × 150
	M6 × 60	M8 × 30	M8 × 70	M8 × 120	M10 × 65	M10 × 100	M12 × 50	M12 × 90	

Cup Square Bolts Only

DIN 603 A2-304

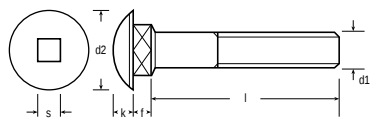

	d1	M5	M6	M8	M10	M12
d2 max.		13.55	16.55	20.65	24.65	30.65
k max.		3.3	3.88	4.88	5.38	6.95
f max.		4.1	4.6	5.6	6.6	8.75
s min.		5.48	6.48	8.58	10.58	12.7

Product Codes Begin **Q20603**

M5 × 16	M6 × 35	M6 × 100	M8 × 60	M8 × 140	M10 × 50	M10 × 130	M12 × 70	M12 × 150
M5 × 25	M6 × 40	M8 × 20	M8 × 70	M8 × 150	M10 × 60	M10 × 140	M12 × 80	
M5 × 40	M6 × 50	M8 × 25	M8 × 80	M10 × 20	M10 × 70	M10 × 150	M12 × 90	
M6 × 16	M6 × 60	M8 × 30	M8 × 90	M10 × 25	M10 × 80	M12 × 30	M12 × 100	
M6 × 20	M6 × 70	M8 × 35	M8 × 100	M10 × 30	M10 × 100	M12 × 40	M12 × 110	
M6 × 25	M6 × 80	M8 × 40	M8 × 110	M10 × 35	M10 × 110	M12 × 50	M12 × 120	
M6 × 30	M6 × 90	M8 × 50	M8 × 130	M10 × 40	M10 × 120	M12 × 60	M12 × 130	

Our Stainless Steel range is constantly being reviewed for additional products and we also offer a comprehensive range of A4 Stainless Steel Fasteners. Please contact your local sales office for further details.



Metric Studding

DIN 975 A2-304

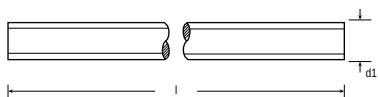

1 Metre Lengths

Product Codes Begin **Q20975**

Size	M3	M4	M5	M6	M8	M10	M12	M14	M16	M18
	M20	M22	M24	M27	M30	M33	M36	M39		

2 Metre Lengths

M8	M10	M12	M20
----	-----	-----	-----

3 Metre Lengths

M5	M6	M8	M10	M12	M14	M16	M18
M20	M27	M30	M33	M36			

UNC Studding

A2-304

3ft Lengths

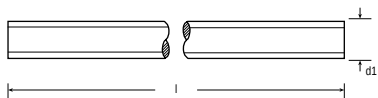

Product Codes Begin **Q2017689C**

Size	1/4 UNC	5/16 UNC	3/8 UNC	1/2 UNC
	5/8 UNC	3/4 UNC	1 UNC	

Stainless Steel Range of Fasteners

Studding Connectors

A2-304

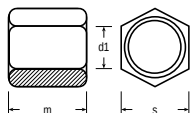

d1	M6	M8	M10	M12	M16	M20
m	18	24	30	36	48	60
s	10	13	17	19	24	30

Product Codes Begin **Q206334**

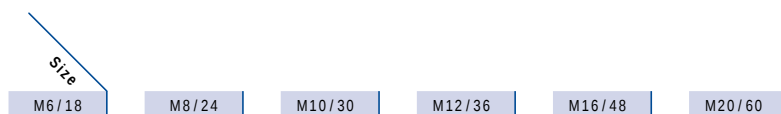

Hexagon Full Nuts

DIN 934 A2-304

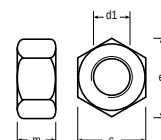

d1	M1	M1.2	M1.4	M1.6	M2	M2.5	M3	M3.5	M4	M5	M6	M8	M10	M12	M14
m max.	0.80	1.00	1.20	1.3	1.6	2.0	2.4	2.8	3.2	4.0	5.0	6.5	8.0	10.0	11.0
e min.	2.72	3.29	3.29	3.41	4.32	5.45	6.01	6.58	7.66	8.79	11.05	14.38	18.90	21.10	24.49
s	2.50	3.00	3.00	3.2	4.0	5.0	5.5	6.0	7.0	8.0	10.0	13.0	17.0	19.0	22.0

M16	M18	M20	M22	M24	M27	M30	M33	M36	M39	M45	M48	M52
13.0	15.0	16.0	18.0	19.0	22.0	24.0	26.0	29.0	31.0	36.0	38.0	42.00
26.79	29.56	32.95	35.03	39.55	45.20	50.85	55.37	60.79	66.44	76.95	82.60	88.25
24.0	27.0	30.0	34.0	36.0	41.0	46.0	50.0	55.0	60.0	70.0	75.0	80.00

Product Codes Begin **Q20934**

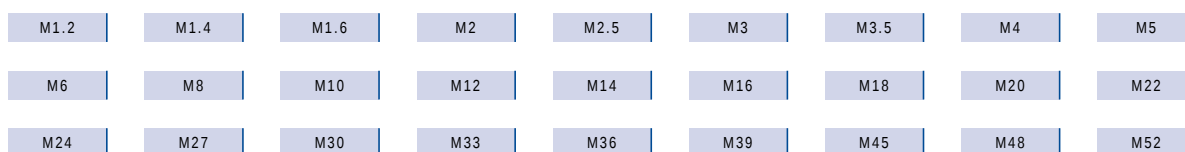

UNC Hexagon Full Nuts

BS1768 A2-304

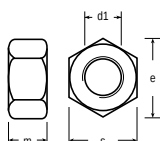

d1	1/4"	5/16"	3/8"	1/2"	5/8"	3/4"
m max.	0.226	0.273	0.337	0.448	0.559	0.665
e max.	0.505	0.577	0.650	0.866	1.083	1.299
s max.	0.438	0.500	0.562	0.750	0.938	1.125

Product Codes Begin **Q2017683**





Nylon Insert Nuts Type P

DIN 982 A2-304

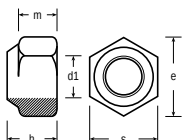

	d1	M5	M6	M8	M10	M12	M16	M20	M24
h		6.3	8	9.5	11.5	14	18	20.00	28.00
m		4.4	4.9	6.44	8.04	10.37	14.1	13.52	16.16
s		8	10	13	17	19	24	30	36
e min.		8.79	11.05	14.38	18.9	21.1	26.75	32.95	39.55

Product Codes Begin **Q20982**

Size

M4	M5	M6	M8	M10	M12	M16	M20	M24
----	----	----	----	-----	-----	-----	-----	-----

Nylon Insert Nuts Type T

DIN 985 A2-304

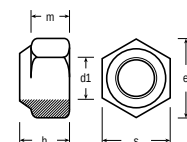

	d1	M2	M2.5	M3	M4	M5	M6	M8	M10	M12
h max.		2.50	3.80	4	5	5	6	8	10	12
m		2.0	2.0	2.4	2.9	3.2	4.0	5.5	6.5	8.0
s		1.60	5.0	5.5	7	8	10	13	17	19
e max.		4.50	5.51	6.01	7.66	8.79	11.05	14.38	18.9	21.1

	M14	M16	M18	M20	M22	M24	M27	M30
14	16	18.5	20	22	24	27	30	
9.5	10.5	13	14	15	15	17	19	
22	24	27	30	34	36	41	46	
24.49	26.75	29.56	32.95	35.03	39.55	45.20	50.85	

Product Codes Begin **Q20985**

M2	M2.5	M3	M4	M5	M6	M8	M10	M12	M14
M16	M18	M20	M22	M24	M27	M30			

UNC Nylon Insert Nuts

A2-304

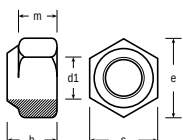

	d1	1/4"	5/16"	3/8"	1/2"	5/8"
s		0.439	0.502	0.564	0.752	0.939
h		0.327	0.359	0.468	0.609	0.765

Product Codes Begin **Q2017684**

Size

1/4 UNC	5/16 UNC	3/8 UNC	1/2 UNC	5/8 UNC	7/16 UNC	3/4 UNC
---------	----------	---------	---------	---------	----------	---------

Stainless Steel Range of Fasteners

Locknuts

DIN 439 A2-304

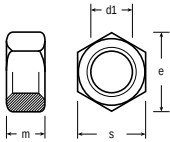

	d1	M2	M2.5	M3	M3.5	M4	M5	M6	M8	M10
e	min.	4.32	5.45	6.01	6.58	7.66	8.79	11.05	14.38	18.90
m	max.	1.2	1.6	1.8	2.0	2.2	2.7	3.2	4.0	5.0
s		4	5	5.5	6	7	8	10	13	17

	M12	M14	M16	M20	M22	M24	M27	M30	M36
	21.10	24.49	26.75	32.95	35.03	39.55	45.20	50.85	60.79
	6.0	7.0	8.0	10.0	11.0	12.0	13.5	15.0	18.0
	19	22	24	30	34	36	41	46	55

Product Codes Begin [Q204390](#)

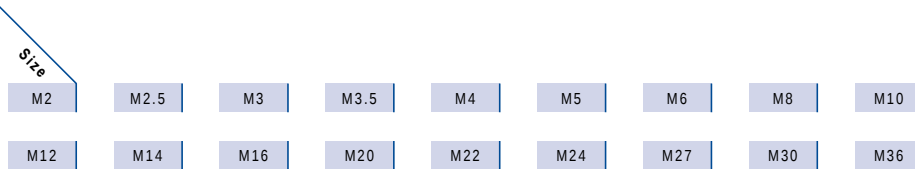

Square Nuts

DIN 557 A2-304

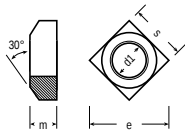

	d1	M5	M6	M8	M10	M12
e		11.3	14.1	18.4	24	26.9
m		4	5	6.5	8	10
s		8	10	13	17	19

Product Codes Begin [Q205570](#)



Dome Nuts

DIN 1587 A2-304

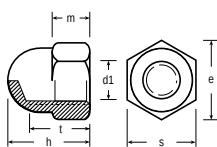

	d1	M3	M4	M5	M6	M8	M10	M12	M14	M16	M20	M24
h		6	8	10	12	15	18	22	25	28	34	42
t	min.	3.6	5.26	7.21	7.71	10.65	12.65	15.65	17.65	20.58	25.58	30.50
m	max.	2.4	3.2	4.0	5.0	6.5	8.0	10.0	11.0	13.0	19.0	19.0
s		5.5	7.0	8.0	10.0	13.0	17.0	19.0	22.0	24.0	36.0	36.0
e	min.	6.08	7.66	8.79	11.05	14.38	18.9	21.1	24.49	26.75	39.55	39.55

Product Codes Begin [Q201587](#)





Hexagon Weld Nuts

DIN 929 A2-304

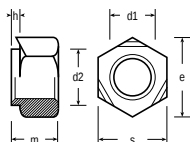

	d1	M4	M5	M6	M8	M10	M12
d2 max.		6	7	8	10.5	12.5	14.8
e max.		9.83	10.95	12.02	15.38	18.74	20.91
m		3.5	4	5	6.5	8	10
s		9	10	11	14	17	19
h		0.65	0.7	0.75	0.9	1.15	1.4

Product Codes Begin **Q20929**

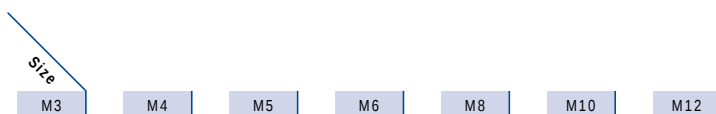

Hexagon Shear Nuts

A2-304



Product Codes Begin **Q20VP16**



Wing Nuts

DIN 315 A2-304



Product Codes Begin **Q20315**



Serrated Flange Nuts

DIN 6923 A2-304

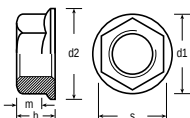

	d1	M4	M5	M6	M8	M10
d2 max.		9.8	11.8	14.2	17.9	21.8
h max.		4.5	6.2	7.3	9.4	11.4
m		3.0	4.7	5.7	7.6	9.6
s		7	8	10	13	15

Product Codes Begin **Q206923S**



Stainless Steel Range of Fasteners

Form A Washers

DIN 125 A2-34

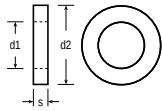

d1	M1.6	M2	M2.5	M3	M3.5	M4	M5	M6	M8	M10	M12
d2 max.	4	5	6	7	8	9	10	12	16	20	24
s nom.	0.3	0.3	0.5	0.5	0.5	0.8	1.0	1.6	1.6	2.0	2.5

	M14	M16	M18	M20	M22	M24	M27	M30	M33	M36	M39
	28	30	34	37	39	44	50	56	60	66	72
	2.5	3.0	3.0	3.0	3.0	4.0	4.0	4.0	5.0	5.0	6.0

Product Codes Begin **Q20125**

M1.6	M2	M2.5	M3	M3.5	M4	M5	M6	M8	M10	M12
M14	M16	M18	M20	M22	M24	M27	M30	M33	M36	M39

Form B Washers

BS4320 A2-304

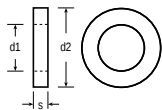

d1	M6	M8	M10	M12	M14	M16	M18	M20
d2 max.	12.5	17	21	24	28	30	34	37
s nom.	0.9	1.1	1.45	1.8	1.8	2.2	2.2	2.2

	M22	M24	M27	M30	M33	M36	M42
	39	44	50	56	60	66	78
	2.2	2.7	2.7	2.7	3.3	3.3	3.0

Product Codes Begin **Q204320B**

M5	M6	M8	M10	M12	M14	M16	M20
M22	M24	M27	M30	M33	M36		



Form C Washers

BS4320 A2-304

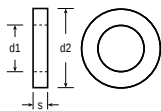

	d1	M4	M5	M6	M8	M10	M12	M16	M20	M24
d2	max.	10.0	12.5	14.0	21.0	24.0	28.0	34.0	39.0	50.0
s	max.	0.9	1.1	1.8	1.8	2.2	2.7	3.3	3.3	4.3

Product Codes Begin **Q204320C**



M4	M5	M6	M8	M10	M12	M16	M20	M24
----	----	----	----	-----	-----	-----	-----	-----

Flat Washers

DIN 9021 A2-304

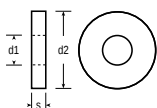

	d1	M2.5	M3	M3.5	M4	M5	M6	M8	M10	M12	M14	M16	M20	M24
d2	max.	8	9	11	12	15	18	24	30	37	44	50	60	72
s	nom.	0.80	0.8	0.80	1.0	1.2	1.6	2.0	2.5	3.0	3.0	3.0	4.0	6.0

Product Codes Begin **Q209021**

M2.5	M3	M3.5	M4	M5	M6	M8	M10	M12	M14
M16	M20	M24							

Flat Washers (Small OD)

DIN 433 A2-304

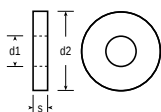

	d1	M1	M2	M2.5	M3	M4	M5	M6	M10
d2		2.5	4.5	5	6	8	9	11	18
s		0.3	0.3	0.5	0.5	0.5	1.0	1.6	1.6

Product Codes Begin **Q20433**

M1	M2.5	M3	M4	M5	M6	M10
----	------	----	----	----	----	-----

Stainless Steel Range of Fasteners

Mudguard Repair Washers

A2-304

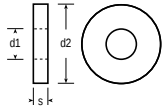

d1	M4	M5	M6	M6	M8	M8	M10	M10	M12
d2	20	25	25	30	25	30	30	35	35
s	1.5	1.5	1.5	1.5	1.5	1.5	1.5	1.5	1.5

Product Codes Begin [Q20140](#)

Size	M4 x 20	M4 x 25	M5 x 15	M5 x 20	M5 x 25	M6 x 20	M6 x 40	M6 x 55	M8 x 20
	M8 x 40	M8 x 50	M10 x 25	M10 x 40	M10 x 50	M12 x 30	M12 x 40	M12 x 50	

Rectangular Section Spring Washers

DIN 127 A2-304

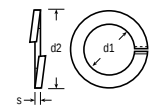

d1	M2	M2.5	M3	M3.5	M4	M5	M6	M8
d2 max.	4.3	5.1	6.1	6.6	7.55	8.15	11.7	14.85
s	0.5	0.6	0.8	0.8	0.9	1.2	1.6	2

M10	M12	M14	M16	M18	M20	M24	M27	M30	M33	M36
18.0	21.0	24.1	27.3	29.4	33.5	39.8	43	48.2	55.2	58.2
2.2	2.5	3	3.5	3.5	4	5	5	6	6	6

Product Codes Begin [Q20127](#)

M2	M2.5	M3	M3.5	M4	M5	M6	M7	M8		
M10	M12	M14	M16	M18	M20	M24	M27	M30	M33	M36

Square Section Spring Washers

DIN 7980 A2-304

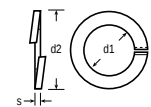

d1	M2	M2.5	M3	M3.5	M4	M5	M6	M8	M10
d2 max.	4.0	4.4	5.6	6.1	7.0	8.8	9.9	12.7	16.0
s	0.89	0.89	1.0	1.0	1.2	1.6	1.6	2.0	2.5

M12	M14	M16	M18	M20	M24	M27	M30
18.0	21.1	24.4	26.4	30.6	35.9	38.9	44.1
2.5	3.0	3.5	3.5	4.5	5.0	5.0	6.0

Product Codes Begin [Q207980](#)

M2	M2.5	M3	M3.5	M4	M5	M6	M8	M10
M12	M14	M16	M18	M20	M24	M27	M30	



Table 3 Washers Light Pattern

A2-304

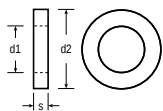

d1	3/16"	1/4"	5/16"	3/8"	7/16"	1/2"	5/8"	3/4"
d2	25/64	9/16	5/8	3/4	7/8	1	1.1/4	1.1/2
s	21g	20g	19g	18g	18g	17g	15g	15g

Product Codes Begin **Q2034103**

Size	1/4	5/16	3/8	7/16	1/2	5/8	3/4	1
------	-----	------	-----	------	-----	-----	-----	---

External Shakeproof Washers

DIN 6797A A2-304

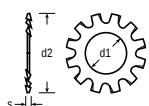

d1	M2	M2.5	M3	M4	M5	M6	M8	M10	M12	M16	M18	M20	M22
d2 max.	4.5	5.5	6	8	10	11	15	18	20.5	26	30	33	36
s	0.3	0.4	0.4	0.5	0.6	0.7	0.8	0.9	1.0	1.2	1.4	1.4	1.5

Product Codes Begin **Q206797A**

M2	M2.5	M3	M4	M5	M6	M8	M10	M12	M16	M18
M20	M22	M24								

External Shakeproof Washers

DIN 6798A A2-304

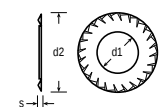

d1	M3	M4	M5	M6	M7	M8	M10	M12	M16	M20
d2 max.	6	8	10	11	12.5	14	18	20.5	26	33
s	0.4	0.5	0.6	0.7	0.8	0.8	0.9	1.0	1.2	1.4

Product Codes Begin **Q206798A**

M3	M4	M5	M6	M7	M8	M10	M12	M16	M20
----	----	----	----	----	----	-----	-----	-----	-----

Stainless Steel Range of Fasteners

Internal Shakeproof Washers

DIN 6797J A2-304

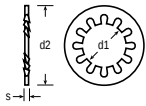

d1	M 2	M 2.5	M 3	M 3.5	M 4	M 5	M 6	M 8
d2 max.	4.5	5.5	6	7	8	10	11	15
s	0.3	0.4	0.4	0.5	0.5	0.6	0.7	0.8
	M 10	M 12	M 14	M 16	M 20	M 22	M 24	M 27
	18	20.5	24	26	33	36	38	44
	0.9	1.0	1.0	1.2	1.4	1.5	1.5	1.6

Product Codes Begin [Q206797J](#)

Size	M 2	M 2.5	M 3	M 3.5	M 4	M 5	M 6	M 8
	M 10	M 12	M 14	M 16	M 20	M 22	M 24	M 27

Internal Shakeproof Washers

DIN 6798J A2-304

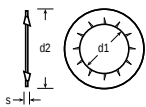

d1	M 2	M 2.5	M 3	M 4	M 5	M 6	M 8	M 10	M 12	M 16
d2 max.	4.5	5.5	6	8	10	11	14	18	20.5	26
s	0.3	0.4	0.4	0.6	0.6	0.7	0.8	0.9	1	1.2

Product Codes Begin [Q206798J](#)

M 2	M 2.5	M 3	M 4	M 5	M 6	M 8	M 10	M 12	M 16
-----	-------	-----	-----	-----	-----	-----	------	------	------

Our Stainless Steel range is constantly being reviewed for additional products and we also offer a comprehensive range of A4 Stainless Steel Fasteners. Please contact your local sales office for further details.



Socket Capscrews

DIN 912 A2-304

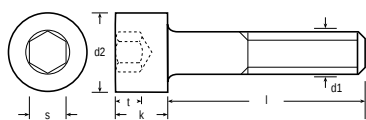

d1	M1.6	M2	M2.5	M3	M4	M5	M6	M8	M10	M12
d2	3	3.8	4.5	5.5	7	8.5	10	13	16	18
k	1.6	2	2.5	3	4	5	6	8	10	12
s	1.5	1.5	2	2.5	3	4	5	6	8	10
t min.	0.7	1	1.1	1.3	2	2.5	3	4	5	6

Product Codes Begin **Q20912**

Size									
M1.6 × 4	M3 × 6	M4 × 35	M5 × 90	M6 × 120	M8 × 100	M10 × 150	M12 × 180	M20 × 65	
M1.6 × 5	M3 × 8	M4 × 40	M5 × 100	M6 × 130	M8 × 110	M10 × 170	M12 × 200	M20 × 70	
M1.6 × 6	M3 × 10	M4 × 50	M5 × 110	M6 × 140	M8 × 120	M10 × 190	M12 × 260	M20 × 75	
M1.6 × 8	M3 × 12	M4 × 55	M5 × 120	M6 × 160	M8 × 130	M10 × 200	M14 × 30	M20 × 80	
M2 × 3	M3 × 14	M4 × 60	M6 × 6	M6 × 180	M8 × 140	M10 × 250	M14 × 50	M20 × 90	
M2 × 4	M3 × 16	M4 × 75	M6 × 8	M6 × 190	M8 × 150	M10 × 260	M14 × 60	M20 × 100	
M2 × 5	M3 × 20	M4 × 80	M6 × 10	M6 × 200	M10 × 12	M12 × 20	M14 × 100	M20 × 110	
M2 × 6	M3 × 25	M4 × 100	M6 × 12	M8 × 10	M10 × 16	M12 × 25	M16 × 25	M20 × 120	
M2 × 8	M3 × 30	M5 × 6	M6 × 14	M8 × 12	M10 × 20	M12 × 30	M16 × 30	M20 × 130	
M2 × 10	M3 × 35	M5 × 8	M6 × 16	M8 × 14	M10 × 25	M12 × 35	M16 × 35	M20 × 140	
M2 × 12	M3 × 40	M5 × 10	M6 × 18	M8 × 16	M10 × 30	M12 × 40	M16 × 40	M20 × 180	
M2 × 16	M3 × 45	M5 × 12	M6 × 20	M8 × 18	M10 × 35	M12 × 45	M16 × 45	M24 × 60	
M2 × 18	M3 × 50	M5 × 14	M6 × 22	M8 × 20	M10 × 40	M12 × 50	M16 × 50	M24 × 100	
M2 × 20	M3 × 55	M5 × 16	M6 × 25	M8 × 22	M10 × 45	M12 × 55	M16 × 55		
M2 × 25	M3 × 60	M5 × 20	M6 × 30	M8 × 25	M10 × 50	M12 × 60	M16 × 60		
M2.5 × 4	M3 × 65	M5 × 22	M6 × 35	M8 × 30	M10 × 55	M12 × 65	M16 × 65		
M2.5 × 5	M4 × 5	M5 × 25	M6 × 40	M8 × 35	M10 × 60	M12 × 70	M16 × 70		
M2.5 × 6	M4 × 6	M5 × 30	M6 × 45	M8 × 40	M10 × 65	M12 × 75	M16 × 75		
M2.5 × 8	M4 × 8	M5 × 35	M6 × 50	M8 × 45	M10 × 70	M12 × 80	M16 × 80		
M2.5 × 10	M4 × 10	M5 × 40	M6 × 55	M8 × 50	M10 × 75	M12 × 85	M16 × 90		
M2.5 × 12	M4 × 12	M5 × 45	M6 × 60	M8 × 55	M10 × 80	M12 × 90	M16 × 100		
M2.5 × 16	M4 × 14	M5 × 50	M6 × 65	M8 × 60	M10 × 85	M12 × 100	M16 × 120		
M2.5 × 20	M4 × 16	M5 × 60	M6 × 70	M8 × 65	M10 × 90	M12 × 110	M16 × 140		
M2.5 × 30	M4 × 18	M5 × 65	M6 × 75	M8 × 70	M10 × 100	M12 × 130	M20 × 30		
M2.5 × 35	M4 × 20	M5 × 70	M6 × 80	M8 × 75	M10 × 110	M12 × 140	M20 × 40		
M2.5 × 40	M4 × 22	M5 × 75	M6 × 90	M8 × 80	M10 × 120	M12 × 150	M20 × 45		
M3 × 3	M4 × 25	M5 × 80	M6 × 100	M8 × 90	M10 × 130	M12 × 160	M20 × 50		
M3 × 5	M4 × 30	M5 × 85	M6 × 110	M8 × 95	M10 × 140	M12 × 170	M20 × 60		

> Stainless Steel Range of Fasteners

Socket Capscrews - Full Thread

DIN 912 A2-304

Product Codes Begin **Q20912FT**

Size						
M2 × 4	M3 × 10	M5 × 6	M6 × 35	M8 × 40	M10 × 50	M16 × 55
M2 × 5	M3 × 12	M5 × 8	M6 × 40	M8 × 45	M10 × 90	M20 × 60
M2 × 6	M3 × 14	M5 × 10	M6 × 50	M8 × 50	M12 × 16	M20 × 65
M2 × 8	M3 × 20	M5 × 12	M6 × 55	M8 × 55	M12 × 20	M20 × 70
M2 × 12	M4 × 5	M5 × 16	M6 × 60	M8 × 60	M12 × 25	M24 × 80
M2 × 20	M4 × 6	M5 × 18	M6 × 70	M8 × 70	M12 × 30	
M2.5 × 6	M4 × 8	M5 × 20	M6 × 80	M8 × 90	M12 × 35	
M2.5 × 8	M4 × 10	M5 × 50	M6 × 90	M8 × 100	M12 × 40	
M2.5 × 16	M4 × 12	M6 × 6	M8 × 12	M10 × 16	M12 × 45	
M2.5 × 20	M4 × 14	M6 × 10	M8 × 16	M10 × 20	M12 × 50	
M2.5 × 25	M4 × 16	M6 × 12	M8 × 18	M10 × 25	M14 × 30	
M3 × 4	M4 × 18	M6 × 16	M8 × 20	M10 × 30	M14 × 50	
M3 × 5	M4 × 20	M6 × 20	M8 × 25	M10 × 35	M16 × 40	
M3 × 6	M4 × 25	M6 × 25	M8 × 30	M10 × 40	M16 × 45	
M3 × 8	M4 × 40	M6 × 30	M8 × 35	M10 × 45	M16 × 50	

Low Head Socket Capscrews

DIN 7984 A2-304

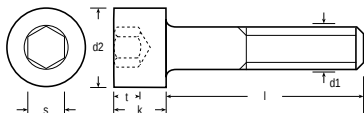

d1	M3	M4	M5	M6	M8	M10	M12
d2	5.5	7	8.5	10	13	16	18
k	2	2.8	3.5	4	5	6	7
s	2	2.5	3	4	5	7	8
t	1.5	2.3	2.7	3	3.8	4.5	5

Product Codes Begin **Q207984**

M3 × 3	M3 × 25	M4 × 22	M5 × 65	M6 × 18	M6 × 50	M8 × 25	M10 × 45	M12 × 100
M3 × 4	M3 × 50	M4 × 50	M5 × 75	M6 × 20	M8 × 16	M8 × 30	M10 × 75	M20 × 75
M3 × 14	M4 × 4	M5 × 50	M6 × 14	M6 × 30	M8 × 18	M10 × 20	M12 × 40	
M3 × 16	M4 × 14	M5 × 55	M6 × 16	M6 × 45	M8 × 20	M10 × 35	M12 × 65	

Our Stainless Steel range is constantly being reviewed for additional products and we also offer a comprehensive range of A4 Stainless Steel Fasteners. Please contact your local sales office for further details.



Socket Setscrews Flat Point

DIN 913 A2-304

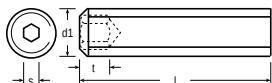

	d1	M3	M4	M5	M6	M8	M10
s		1.5	2.0	2.5	3.0	4.0	5.0
t	min.	1.2	1.5	2.0	2.0	3.0	4.0

Product Codes Begin **Q20913**

Size	M3 × 3	M3 × 4	M3 × 6	M3 × 8	M3 × 10	M3 × 12	M4 × 4	M4 × 5	M4 × 8	M4 × 10	M4 × 12	M5 × 6	M5 × 10	M5 × 12	M6 × 6	M6 × 10	M8 × 10	M8 × 35	M10 × 16	M12 × 35

Socket Setscrews Cone Point

DIN 914 A2-304

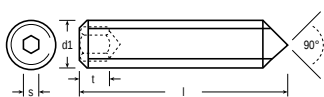

	d1	M2	M2.5	M3	M4	M5	M6	M8	M10
s		0.9	1.3	1.5	2.0	2.5	3.0	4.0	5.0
t	min.	0.8	1.2	1.2	1.5	2.0	2.0	3.0	4.0

Product Codes Begin **Q20914**

M2 × 3	M4 × 6	M5 × 6	M5 × 25	M6 × 25	M8 × 30
M2.5 × 3	M4 × 8	M5 × 7	M6 × 6	M6 × 30	M8 × 50
M3 × 8	M4 × 10	M5 × 8	M6 × 8	M8 × 8	M10 × 12
M3 × 10	M4 × 16	M5 × 10	M6 × 10	M8 × 10	M10 × 16
M4 × 4	M4 × 25	M5 × 12	M6 × 12	M8 × 12	M10 × 20
M4 × 5	M5 × 5	M5 × 20	M6 × 16	M8 × 16	M10 × 40

Socket Setscrews Dog Point

DIN 915 A2-304



	d1	M3	M4	M5	M6	M8	M10
d2	max.	2	2.5	3.5	4.0	5.5	7.0
s		1.5	2.0	2.5	3.0	4.0	5.0
t	max.	1.75	2.25	2.75	3.25	4.3	5.3
z	max.	2	2.5	3.0	3.5	5.0	6.0

Product Codes Begin **Q20915**

M3 × 5	M3 × 10	M4 × 8	M5 × 6	M6 × 6	M6 × 16	M8 × 10	M10 × 10	M10 × 30
M3 × 6	M4 × 5	M4 × 10	M5 × 8	M6 × 10	M6 × 20	M8 × 12	M10 × 12	M10 × 40
M3 × 8	M4 × 6	M4 × 16	M5 × 10	M6 × 12	M6 × 25	M8 × 20	M10 × 16	

Stainless Steel Range of Fasteners

Socket Setscrews Cup Point

DIN 916 A2-304

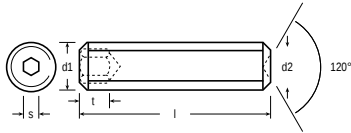

	d1	M2	M2.5	M3	M4	M5	M6	M8	M10	M12	M16
d2 min.		0.75	0.95	1.15	1.75	2.25	2.75	4.7	5.7	7.64	9.64
s		0.9	1.3	1.5	2	2.5	3	4	5	6	7
t max.		1.7	2.0	2.0	2.5	3	3.5	5	6	8	10

Product Codes Begin **Q20916**

Size								
M2 × 4	M3 × 5	M4 × 12	M5 × 16	M6 × 16	M8 × 20	M10 × 25	M12 × 35	
M2 × 5	M3 × 6	M4 × 14	M5 × 20	M6 × 20	M8 × 25	M10 × 30	M12 × 50	
M2 × 6	M3 × 8	M4 × 16	M5 × 25	M6 × 25	M8 × 30	M10 × 35	M12 × 60	
M2 × 10	M3 × 12	M4 × 18	M5 × 30	M6 × 30	M8 × 35	M10 × 40	M16 × 16	
M2.5 × 3	M4 × 3	M4 × 20	M5 × 35	M6 × 40	M8 × 40	M10 × 50	M16 × 20	
M2.5 × 4	M4 × 4	M5 × 5	M5 × 40	M6 × 50	M8 × 50	M10 × 60	M16 × 25	
M2.5 × 5	M4 × 5	M5 × 6	M6 × 6	M8 × 8	M10 × 10	M12 × 12	M16 × 35	
M2.5 × 6	M4 × 6	M5 × 8	M6 × 8	M8 × 10	M10 × 12	M12 × 16	M16 × 40	
M3 × 3	M4 × 8	M5 × 10	M6 × 10	M8 × 12	M10 × 16	M12 × 20	M16 × 50	
M3 × 4	M4 × 10	M5 × 12	M6 × 12	M8 × 16	M10 × 20	M12 × 25	M16 × 60	

Countersunk Socket Screws

DIN 7991 A2-304

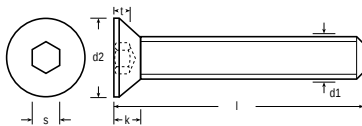

	d1	M2.5	M3	M4	M5	M6	M8	M10	M12	M16	M20
d2		5	6	8	10	12	16	20	24	30	36
k max.		1.5	1.7	2.3	2.8	3.3	4.4	5.5	6.5	7.5	8.5
s		1.5	2	2.5	3	4	5	6	8	10	12
t		0.8	1.2	1.8	2.3	2.5	3.5	4.4	4.6	5.3	5.9

Product Codes Begin **Q20991**

M2.5 × 6	M4 × 8	M5 × 16	M6 × 25	M8 × 12	M8 × 70	M10 × 60	M12 × 50	M16 × 40
M2.5 × 10	M4 × 10	M5 × 20	M6 × 30	M8 × 16	M8 × 80	M10 × 65	M12 × 60	M16 × 45
M3 × 5	M4 × 12	M5 × 25	M6 × 35	M8 × 20	M8 × 90	M10 × 70	M12 × 65	M16 × 50
M3 × 6	M4 × 16	M5 × 30	M6 × 40	M8 × 25	M8 × 100	M10 × 75	M12 × 70	M16 × 60
M3 × 8	M4 × 20	M5 × 35	M6 × 45	M8 × 30	M10 × 16	M10 × 80	M12 × 75	M16 × 70
M3 × 10	M4 × 25	M5 × 40	M6 × 50	M8 × 35	M10 × 20	M10 × 90	M12 × 80	M16 × 80
M3 × 12	M4 × 30	M5 × 50	M6 × 60	M8 × 40	M10 × 25	M10 × 100	M12 × 90	M16 × 100
M3 × 16	M4 × 35	M5 × 60	M6 × 65	M8 × 45	M10 × 30	M12 × 20	M12 × 100	M20 × 50
M3 × 20	M4 × 40	M6 × 10	M6 × 70	M8 × 50	M10 × 35	M12 × 25	M16 × 25	
M3 × 25	M5 × 8	M6 × 12	M6 × 80	M8 × 55	M10 × 40	M12 × 30	M16 × 30	
M3 × 30	M5 × 10	M6 × 16	M6 × 100	M8 × 60	M10 × 45	M12 × 35	M16 × 35	
M4 × 6	M5 × 12	M6 × 20	M8 × 10	M8 × 65	M10 × 50	M12 × 40		

Our Stainless Steel range is constantly being reviewed for additional products and we also offer a comprehensive range of A4 Stainless Steel Fasteners. Please contact your local sales office for further details.



Socket Button Head Screws

ISO 7380 A2-304

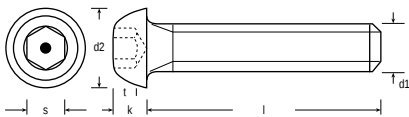

d1	M3	M4	M5	M6	M8	M10	M12
d2 max.	5.7	7.6	9.5	10.5	14	18	21
k max.	1.65	2.2	2.75	3.3	4.4	5.5	6.6
s	2	2.5	3	4	5	6	8
t min.	1.04	1.3	1.56	2.08	2.6	3.12	4.16

Product Codes Begin **Q207380**

Size							
M3 × 5	M4 × 12	M5 × 16	M6 × 16	M6 × 100	M8 × 65	M10 × 60	M12 × 70
M3 × 6	M4 × 14	M5 × 18	M6 × 18	M6 × 120	M8 × 70	M10 × 65	M12 × 80
M3 × 8	M4 × 16	M5 × 20	M6 × 20	M8 × 10	M8 × 75	M10 × 70	M12 × 90
M3 × 10	M4 × 18	M5 × 22	M6 × 22	M8 × 12	M8 × 80	M10 × 75	M12 × 100
M3 × 12	M4 × 20	M5 × 25	M6 × 25	M8 × 14	M8 × 90	M10 × 80	
M3 × 14	M4 × 25	M5 × 30	M6 × 30	M8 × 16	M8 × 100	M10 × 90	
M3 × 16	M4 × 30	M5 × 35	M6 × 35	M8 × 18	M8 × 120	M10 × 100	
M3 × 20	M4 × 35	M5 × 40	M6 × 40	M8 × 20	M10 × 12	M12 × 16	
M3 × 22	M4 × 40	M5 × 45	M6 × 45	M8 × 22	M10 × 16	M12 × 20	
M3 × 25	M4 × 45	M5 × 50	M6 × 50	M8 × 25	M10 × 20	M12 × 25	
M3 × 30	M4 × 50	M5 × 60	M6 × 55	M8 × 30	M10 × 25	M12 × 30	
M3 × 35	M4 × 55	M5 × 65	M6 × 60	M8 × 35	M10 × 30	M12 × 35	
M3 × 50	M5 × 6	M6 × 6	M6 × 65	M8 × 40	M10 × 35	M12 × 40	
M4 × 5	M5 × 8	M6 × 8	M6 × 70	M8 × 45	M10 × 40	M12 × 45	
M4 × 6	M5 × 10	M6 × 10	M6 × 75	M8 × 50	M10 × 45	M12 × 50	
M4 × 8	M5 × 12	M6 × 12	M6 × 80	M8 × 55	M10 × 50	M12 × 55	
M4 × 10	M5 × 14	M6 × 14	M6 × 90	M8 × 60	M10 × 55	M12 × 60	

Socket Button Head Screws - Torx

ISO 7380 A2-304

Product Codes Begin **Q207380TX**

M3 × 5	M4 × 8	M5 × 25	M6 × 18	M8 × 22	M10 × 12
M3 × 6	M4 × 10	M5 × 30	M6 × 20	M8 × 25	M10 × 20
M3 × 8	M4 × 12	M5 × 35	M6 × 25	M8 × 30	M10 × 25
M3 × 10	M4 × 20	M5 × 40	M6 × 45	M8 × 35	M10 × 35
M3 × 12	M4 × 30	M5 × 45	M6 × 60	M8 × 40	M10 × 50
M3 × 14	M4 × 40	M6 × 8	M6 × 70	M8 × 45	
M3 × 16	M5 × 8	M6 × 10	M6 × 80	M8 × 50	
M3 × 20	M5 × 10	M6 × 12	M8 × 10	M8 × 55	
M3 × 30	M5 × 16	M6 × 14	M8 × 16	M8 × 60	
M4 × 4	M5 × 20	M6 × 16	M8 × 20	M8 × 80	

Stainless Steel Range of Fasteners

Countersunk Head Recessed Machine Screws

DIN 965 A2-304

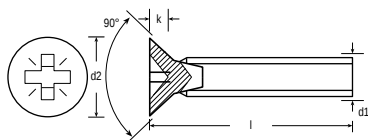

d1	M1.6	M2	M2.5	M3	M3.5	M4	M5	M6	M8
d2	3.0	3.8	4.7	5.6	6.5	7.5	9.2	11	14.5
k	max. 0.96	1.2	1.5	1.65	1.93	2.2	2.5	3	4
Recess no.	0	1	1	1	2	2	2	3	4

Product Codes Begin [Q20965](#)

Size	M2 × 12	M2.5 × 20	M3 × 20	M4 × 25	M5 × 10	M5 × 40	M6 × 30	M8 × 25
M1.6 × 3	M2 × 12	M2.5 × 20	M3 × 20	M4 × 25	M5 × 10	M5 × 40	M6 × 30	M8 × 25
M1.6 × 4	M2 × 16	M2.5 × 25	M4 × 5	M4 × 30	M5 × 12	M5 × 50	M6 × 35	M8 × 30
M1.6 × 5	M2.5 × 4	M3 × 5	M4 × 6	M4 × 35	M5 × 14	M6 × 10	M6 × 40	M8 × 40
M1.6 × 6	M2.5 × 6	M3 × 6	M4 × 8	M4 × 40	M5 × 16	M6 × 12	M6 × 45	M8 × 50
M2 × 4	M2.5 × 8	M3 × 8	M4 × 10	M4 × 45	M5 × 20	M6 × 14	M6 × 50	
M2 × 5	M2.5 × 10	M3 × 10	M4 × 12	M4 × 50	M5 × 25	M6 × 16	M6 × 60	
M2 × 8	M2.5 × 12	M3 × 12	M4 × 16	M4 × 60	M5 × 30	M6 × 20	M8 × 16	
M2 × 10	M2.5 × 16	M3 × 16	M4 × 20	M5 × 8	M5 × 35	M6 × 25	M8 × 20	

Pan Head Recessed Machine Screws

DIN 7985 A2-304

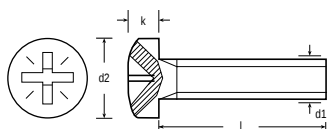

d1	M1.6	M2	M2.5	M3	M3.5	M4	M5	M6	M8
d2	3.2	4	5	6	7	8	10	12	16
k	max. 1.42	1.72	2.12	2.52	2.82	3.25	3.95	4.75	6.15
Recess no.	0	1	1	1	2	2	2	3	4

Product Codes Begin [Q207985](#)

M1.6 × 2	M2 × 6	M2.5 × 10	M3 × 12	M3.5 × 16	M4 × 20	M5 × 16	M6 × 12	M8 × 12
M1.6 × 3	M2 × 8	M2.5 × 12	M3 × 14	M3.5 × 20	M4 × 25	M5 × 20	M6 × 16	M8 × 20
M1.6 × 4	M2 × 10	M2.5 × 16	M3 × 16	M3.5 × 25	M4 × 30	M5 × 25	M6 × 18	M8 × 25
M1.6 × 5	M2 × 12	M2.5 × 20	M3 × 20	M3.5 × 30	M4 × 35	M5 × 30	M6 × 20	
M1.6 × 6	M2 × 16	M2.5 × 25	M3 × 25	M4 × 6	M4 × 40	M5 × 35	M6 × 25	
M1.6 × 8	M2 × 20	M3 × 4	M3 × 30	M4 × 8	M5 × 6	M5 × 40	M6 × 30	
M1.6 × 10	M2.5 × 4	M3 × 5	M3.5 × 5	M4 × 10	M5 × 8	M5 × 45	M6 × 35	
M2 × 3	M2.5 × 5	M3 × 6	M3.5 × 6	M4 × 12	M5 × 10	M5 × 50	M6 × 40	
M2 × 4	M2.5 × 6	M3 × 8	M3.5 × 8	M4 × 14	M5 × 12	M6 × 8	M6 × 50	
M2 × 5	M2.5 × 8	M3 × 10	M3.5 × 12	M4 × 16	M5 × 14	M6 × 10	M6 × 60	

Our Stainless Steel range is constantly being reviewed for additional products and we also offer a comprehensive range of A4 Stainless Steel Fasteners. Please contact your local sales office for further details.



Pan Head Recessed Machine Screws-Tx Drive

DIN 7985 A2-304

Product Codes Begin **Q207985**

Size									
M1.6 × 2	M1.6 × 16	M2.5 × 10	M2.5 × 28	M3 × 12	M4 × 8	M4 × 65	M6 × 14	M6 × 65	
M1.6 × 4	M1.6 × 20	M2.5 × 12	M3 × 3	M3 × 14	M4 × 12	M5 × 12	M6 × 16	M8 × 10	
M1.6 × 5	M2 × 5	M2.5 × 14	M3 × 4	M3 × 25	M4 × 14	M5 × 16	M6 × 20	M8 × 12	
M1.6 × 8	M2 × 14	M2.5 × 16	M3 × 5	M3 × 35	M4 × 16	M5 × 18	M6 × 25	M8 × 20	
M1.6 × 10	M2.5 × 4	M2.5 × 18	M3 × 6	M3 × 40	M4 × 35	M5 × 20	M6 × 28	M8 × 25	
M1.6 × 12	M2.5 × 6	M2.5 × 20	M3 × 8	M4 × 5	M4 × 55	M5 × 30	M6 × 30	M8 × 30	
M1.6 × 14	M2.5 × 8	M2.5 × 25	M3 × 10	M4 × 6	M4 × 60	M5 × 55	M6 × 40		

Raised Head Recessed Machine Screws

DIN 966 A2-304

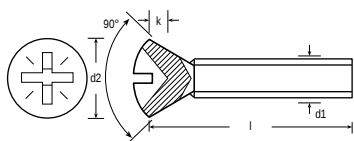

d1	M5	M6
d2	9.2	11
k	max. 2.5	3
Recess no.	2	3

Product Codes Begin **Q20966**

M5 × 10
M5 × 16
M5 × 50
M6 × 16

Stainless Steel Range of Fasteners

Countersunk Head Slotted Machine Screws

DIN 963 A2-304

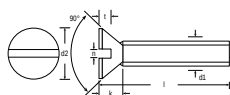

d1	M1.4	M1.6	M2	M2.5	M3	M3.5	M4	M5	M6	M8	M10	M12
d2	2.6	3	3.8	4.7	5.6	6.5	7.5	9.2	11	14.5	18	22
k max.	0.84	0.96	1.2	1.5	1.65	1.93	2.2	2.5	3	4	5	6
n	0.5	0.4	0.5	0.6	0.8	0.8	1	1.2	1.6	2	2.5	3
t min.	0.32	0.32	0.4	0.5	0.6	0.7	0.8	1	1.2	1.6	2	2.4

Product Codes Begin **Q20963**

Size								
M1.4 × 3	M2 × 4	M2.5 × 20	M4 × 25	M5 × 40	M6 × 45	M8 × 45	M10 × 50	
M1.4 × 4	M2 × 5	M3 × 6	M4 × 30	M5 × 50	M6 × 50	M8 × 50	M10 × 55	
M1.4 × 5	M2 × 6	M3 × 8	M4 × 35	M5 × 60	M6 × 60	M8 × 60	M10 × 60	
M1.4 × 6	M2 × 8	M3 × 10	M4 × 40	M5 × 70	M6 × 65	M8 × 70	M10 × 70	
M1.4 × 8	M2 × 10	M3 × 12	M4 × 50	M5 × 80	M6 × 70	M8 × 75	M10 × 75	
M1.6 × 3	M2 × 12	M3 × 16	M4 × 60	M5 × 100	M6 × 75	M8 × 80	M10 × 80	
M1.6 × 4	M2 × 14	M3 × 20	M5 × 8	M6 × 10	M6 × 80	M8 × 90	M10 × 100	
M1.6 × 5	M2 × 16	M3 × 25	M5 × 10	M6 × 12	M6 × 100	M8 × 100	M12 × 45	
M1.6 × 6	M2 × 20	M3 × 30	M5 × 12	M6 × 16	M8 × 16	M10 × 16	M12 × 100	
M1.6 × 8	M2.5 × 4	M4 × 8	M5 × 16	M6 × 20	M8 × 20	M10 × 20		
M1.6 × 10	M2.5 × 5	M4 × 10	M5 × 20	M6 × 25	M8 × 25	M10 × 25		
M1.6 × 12	M2.5 × 6	M4 × 12	M5 × 25	M6 × 30	M8 × 30	M10 × 30		
M1.6 × 14	M2.5 × 10	M4 × 16	M5 × 30	M6 × 35	M8 × 35	M10 × 35		
M1.6 × 16	M2.5 × 16	M4 × 20	M5 × 35	M6 × 40	M8 × 40	M10 × 40		

Pan Head Slotted Machine Screws

DIN 85 A2-304

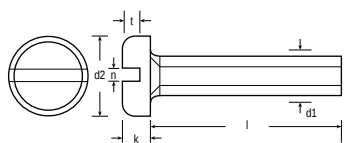

d1	M1.6	M2	M2.5	M3	M3.5	M4	M5	M6	M8	M10
d2	3.2	4	5	6	7	8	10	12	16	20
k	1.0	1.3	1.5	1.8	2.1	2.4	3	3.6	4.8	6
n	0.6	0.5	0.6	0.8	1	1.2	1.2	1.6	2	2.5
t min.	0.35	0.5	0.6	0.7	0.8	1	1.2	1.4	1.9	2.4

Product Codes Begin **Q20850**

M1.6 × 5	M2 × 18	M3 × 6	M4 × 12	M5 × 20	M6 × 16	M8 × 25
M1.6 × 6	M2 × 20	M3 × 8	M4 × 16	M5 × 25	M6 × 20	M8 × 30
M1.6 × 8	M2.5 × 4	M3 × 10	M4 × 20	M5 × 30	M6 × 25	M8 × 40
M1.6 × 10	M2.5 × 5	M3 × 12	M4 × 25	M5 × 35	M6 × 30	M8 × 50
M2 × 3	M2.5 × 6	M3 × 16	M4 × 30	M5 × 40	M6 × 35	M8 × 60
M2 × 4	M2.5 × 8	M3 × 20	M4 × 40	M5 × 45	M6 × 40	M10 × 20
M2 × 5	M2.5 × 10	M3 × 25	M4 × 50	M5 × 50	M6 × 50	M10 × 25
M2 × 6	M2.5 × 12	M3 × 30	M5 × 6	M5 × 60	M6 × 60	
M2 × 8	M2.5 × 16	M3 × 40	M5 × 8	M5 × 75	M6 × 70	
M2 × 12	M2.5 × 20	M4 × 6	M5 × 10	M6 × 8	M8 × 12	
M2 × 14	M2.5 × 25	M4 × 8	M5 × 12	M6 × 10	M8 × 16	
M2 × 16	M3 × 5	M4 × 10	M5 × 16	M6 × 12	M8 × 20	



Raised Head Slotted Machine Screws

DIN 964 A2-304

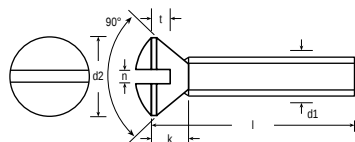

	d1	M4	M5
d2		7.5	9.2
k max.		2.2	2.5
n		1	1.2
t min.		1.6	2

Product Codes Begin **Q20964**

Size
M4 × 12
M5 × 16

Cheese Head Slotted Machine Screws

DIN 84 A2-304

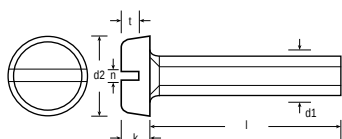

	d1	M1.6	M2	M2.5	M3	M3.5	M4	M5	M6	M8
d2		3	3.8	4.5	5.5	6	7	8.5	10	13
k		1	1.3	1.6	2	2.4	2.6	3.3	3.9	5
n		0.4	0.5	0.6	0.8	1	1.2	1.2	1.6	2
t min.		0.45	0.6	0.7	0.85	1	1.1	1.3	1.6	2

Product Codes Begin **Q20840**

M2.5 × 16	M3 × 25	M4 × 20	M5 × 25	M6 × 40
M2.5 × 18	M3 × 30	M4 × 25	M5 × 30	M6 × 50
M2.5 × 20	M3 × 35	M4 × 30	M5 × 40	M8 × 25
M3 × 5	M3 × 40	M4 × 40	M6 × 10	M8 × 35
M3 × 6	M3.5 × 20	M5 × 6	M6 × 12	M8 × 50
M3 × 8	M4 × 6	M5 × 8	M6 × 16	
M3 × 10	M4 × 8	M5 × 10	M6 × 20	
M3 × 12	M4 × 10	M5 × 12	M6 × 25	
M3 × 16	M4 × 12	M5 × 16	M6 × 30	
M3 × 20	M4 × 16	M5 × 20	M6 × 35	

Two Pin Pan Head Machine Screws

A2-304

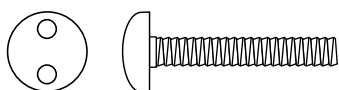

Product Codes Begin **Q20VP02**

M4 × 16	M5 × 20	M6 × 20
---------	---------	---------



Stainless Steel Range of Fasteners

Two Pin Bits – 25mm

A2-304

Product Codes Begin **Q90VPBTP**

Size	2 Pin Bits		Machine Screw Diameter	2 Pin Bits
No. 8 (4mm)	No. 6	No. 8	M3	No. 4
No. 10 (5mm)	No. 8	No. 10	M3.5	No. 6
No. 14 (6mm)	No. 10	No. 12	M4	No. 8
	No. 12	No. 14	M5	No. 10
	No. 14		M6	No. 14

Pin Hexagon Countersunk Head Self Tapping Screws

A2-304



Product Codes Begin **Q20VP08**

3.5 × 25	4.8 × 13	4.8 × 50
4.2 × 16	4.8 × 25	

Pin Hexagon Button Head Self Tapping Screws

A2-304



Product Codes Begin **Q20VP07**

3.5 × 25	4.2 × 38	4.8 × 38
4.2 × 13	4.8 × 16	4.8 × 50
4.2 × 16	4.8 × 25	
4.2 × 32	4.8 × 32	

Our Stainless Steel range is constantly being reviewed for additional products and we also offer a comprehensive range of A4 Stainless Steel Fasteners. Please contact your local sales office for further details.



Pin Hexagon Countersunk Head Machine Screws

A2-304

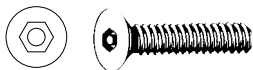

Product Codes Begin **Q20VP06**

Size		
M4 × 16	M6 × 35	M8 × 50
M4 × 30	M8 × 20	M10 × 20
M5 × 12	M8 × 25	M10 × 25
M6 × 16	M8 × 30	M10 × 50
M6 × 20	M8 × 35	
M6 × 30	M8 × 40	

Pin Hexagon Button Head Machine Screws

A2-304



Product Codes Begin **Q20VP05**

M3 × 8	M4 × 30	M5 × 25	M6 × 16	M6 × 40	M8 × 20	M8 × 50	M10 × 40
M4 × 10	M5 × 10	M5 × 30	M6 × 20	M6 × 45	M8 × 25	M8 × 60	M10 × 50
M4 × 12	M5 × 12	M5 × 40	M6 × 25	M6 × 50	M8 × 30	M10 × 20	
M4 × 16	M5 × 16	M6 × 10	M6 × 30	M6 × 60	M8 × 35	M10 × 25	
M4 × 20	M5 × 20	M6 × 12	M6 × 35	M8 × 16	M8 × 40	M10 × 30	



Pin Hexagon Bits – 25mm

A2-304

Product Codes Begin **Q90VPBPH**

2mm	2.5mm	3mm	4mm	5mm	6mm
-----	-------	-----	-----	-----	-----



Stainless Steel Range of Fasteners

Pin Hexagon Keys

A2-304



Product Codes Begin **Q90VPKPH**

2mm	2.5mm	3mm	4mm
5mm	6mm	8mm	

Self Tapping Screw Gauge	Bits / Keys	Pin Hex Diameter	Machine Screw Diameter	Bits / Keys	Pin Hex Keys
No. 6	2mm a/f		M3		2mm a/f
No. 8	2.5mm a/f		M4		2.5mm a/f
No. 10	3mm a/f		M5		3mm a/f
No. 12	4mm a/f		M6		4mm a/f
No. 14	4mm a/f		M8		5mm a/f
			M10		6mm a/f

Tamper TX Countersunk Head Self Tapping Screws

A2-304



Product Codes Begin **Q20VP15**

3.5 × 19	3.5 × 25	3.5 × 38	4.2 × 16	4.2 × 19	4.2 × 25	4.2 × 32	
4.2 × 38	4.2 × 50	4.8 × 19	4.8 × 32	4.8 × 38	4.8 × 50	5.5 × 32	5.5 × 38

Tamper TX Button Head Self Tapping Screws

A2-304



Product Codes Begin **Q20VP14**

3.5 × 19	4.2 × 13	4.2 × 19	4.2 × 25	4.2 × 38	4.8 × 13	4.8 × 16
4.8 × 19	4.8 × 25	4.8 × 38	5.5 × 25	5.5 × 38	5.5 × 50	

Tamper TX Countersunk Head Machine Screws

A2-304



Product Codes Begin **Q20VP13**

M3 × 6	M3 × 8	M4 × 8	M4 × 10	M4 × 12	M4 × 16	M4 × 20
M4 × 25	M5 × 10	M5 × 12	M5 × 16	M5 × 20	M5 × 25	M5 × 30
M5 × 40	M6 × 12	M6 × 16	M6 × 20	M6 × 30		



Tamper TX Button Head Machine Screws

A2-304



Product Codes Begin **Q20VP12**

M3 × 6	M3 × 8	M3 × 12	M3 × 20	M4 × 8	M4 × 10	M4 × 12	M4 × 16
M4 × 20	M4 × 25	M4 × 30	M5 × 10	M5 × 12	M5 × 16	M5 × 20	M5 × 25
M5 × 30	M6 × 10	M6 × 12	M6 × 16	M6 × 20	M6 × 25	M6 × 30	M6 × 40
M8 × 12	M8 × 16	M8 × 20	M8 × 25	M8 × 30	M8 × 40	M8 × 50	
M10 × 20	M10 × 25	M10 × 30	M10 × 35	M10 × 40	M10 × 50	M10 × 60	

Tamper TX Bit – 25mm

A2-304



Product Codes Begin **Q90VPBTT**

Size	Product Codes Begin Q90VPBTT		Tamper TX Button Bits / Keys		Tamper TX Csk Bits / Keys		Machine Screw Diameter	
	TX15	TX20	TX25					
	TX27	TX40	TX45					
				No. 6	TX-10	TX-15	M3	TX-10
				No. 8	TX-15	TX-20	M4	TX-20
				No. 10	TX-25	TX-25	M5	TX-25
				No. 12	TX-27	TX-27	M6	TX-30
				No. 14	TX-27	TX-30	M8	TX-40
							M10	TX-45

Tamper TX Key

A2-304



Product Codes Begin **Q90VPKTT**

Size						
	TX10	TX20	TX25	TX30	TX40	TX45

Throughbolts

Throughbolt • Zinc Plated and Yellow Passivated • Min 5µm



A torque controlled anchor suitable for use in concrete over C20/25

Part Number	Anchor Hole Size mm	Anchor Length mm	Thread Length mm	Max Fixture Thickness mm	Minimum Hole Depth mm	Quantity Per Box
TB06045	6	45	20	5	35	100
TB06055	6	55	30	15	35	100
TB06085	6	85	60	45	35	100
TB08050	8	50	20	5	40	100
TB08065	8	65	35	20	40	100
TB08080	8	80	50	35	40	50
TB08100	8	100	70	55	40	50
TB08130	8	130	85	85	40	50
TB10065	10	65	25	8	50	50
TB10075	10	75	35	18	50	50
TB10090	10	90	50	33	50	50
TB10100	10	100	50	43	50	50
TB10120	10	120	80	63	50	20
TB10150	10	150	110	93	50	20
TB10175	10	175	135	118	50	20
TB12080	12	80	30	5	65	20
TB12100	12	100	50	25	65	20
TB12120	12	120	70	45	65	20
TB12140	12	140	90	65	65	20
TB12180	12	180	90	105	65	20
TB16105	16	105	60	10	85	20
TB16125	16	125	65	30	85	20
TB16150	16	150	90	55	85	20
TB16175	16	175	90	80	85	10
TB16220	16	220	90	125	85	10
TB20130	20	130	60	20	100	10
TB20160	20	160	60	50	100	10
TB20215	20	215	60	105	100	10
TB24180	24	180	65	45	120	10
TB24260	24	260	65	125	120	5

Wirehangers



Part Number	Anchor Hole Size mm	Anchor Length mm	Eye Diameter mm	Minimum Hole Depth mm	Rec Tensile Load KN	Qty Per Box/Outer
TW06055	6	55	6	40	1.5	100



Option 7 Approved Throughbolt • Clear Zinc Plated • Min 5µm



A throughbolt with a European Technical Approval, which is a torque controlled anchor suitable for use in concrete over C20/25.



Part Number	Anchor Hole Size mm	Anchor Length mm	Shallow Embedment Hole Depth mm	Max Fixture Thickness Shallow Embedment mm	Deep Embedment Hole Depth mm	Max Fixture Thickness Deep Embedment mm	Quantity Per Box
AWA06060	6	60	35	21	55	2	100
AWA06080	6	80	35	41	55	22	100
AWA08050*	8	50	40	5	N/A	-	100
AWA08065	8	65	50	8	N/A	-	100
AWA08075	8	75	50	18	65	5	50
AWA08090	8	90	50	33	65	20	50
AWA08100	8	100	50	43	65	30	50
AWA08115	8	115	50	58	65	45	50
AWA08130	8	130	50	73	65	60	50
AWA10065*	10	65	50	3	N/A	-	50
AWA10075	10	75	60	8	N/A	-	50
AWA10090	10	90	60	23	75	10	50
AWA10100	10	100	60	33	75	20	50
AWA10120	10	120	60	53	75	40	20
AWA10150	10	150	60	83	75	70	20
AWA12080	12	80	70	3	N/A	-	20
AWA12090	12	90	70	13	N/A	-	20
AWA12100	12	100	70	23	85	8	20
AWA12110	12	110	70	33	85	18	20
AWA12120	12	120	70	43	85	28	20
AWA12140	12	140	70	63	85	48	20
AWA12160	12	160	70	83	85	68	20
AWA12180	12	180	70	103	85	88	20
AWA16105*	16	105	90	3	N/A	-	20
AWA16125	16	125	90	23	110	3	20
AWA16145	16	145	90	43	110	23	20
AWA16170	16	170	90	68	110	48	10
AWA16220	16	220	90	118	110	98	10
AWA20130*	20	130	95	23	N/A	-	10
AWA20170	20	170	95	63	135	23	10
AWA20215	20	215	95	108	135	68	10
AWA24180*	24	180	120	49	160	4	10
AWA24260*	24	260	120	129	160	84	5

* Not included in approval

Option 1 Approved Throughbolt • Clear Zinc Plated



A throughbolt with an Option 1 European Technical Approval, suitable for cracked and non-cracked concrete.



Part Number	Anchor Hole Size mm	Anchor Length mm	Thread Length mm	Max Fixture Thickness mm	Minimum Hole Depth mm	Quantity Per Box
ETA08075	8	75	20	10	60	100
ETA08095	8	95	40	30	60	100
ETA08115	8	115	60	50	60	100
ETA10090	10	90	20	10	75	50
ETA10110	10	110	40	30	75	50
ETA10130	10	130	60	50	75	50
ETA12110	12	110	30	15	90	25
ETA12125	12	125	45	30	90	25
ETA12160	12	160	80	65	90	25
ETA12180	12	180	80	85	90	25
ETA16135	16	135	35	15	110	20
ETA16170	16	170	70	50	110	20
ETA16200	16	200	80	80	110	10

Option 7 Approved Throughbolt • Stainless Steel Grade A4-316

The throughbolt is a torque controlled anchor suitable for use in non-cracked concrete over C20/25.



Part Number	Anchor Hole Size mm	Anchor Length mm	Thread Length mm	Max Fixture Thickness mm	Minimum Hole Depth mm	Quantity Per Box
TSS06040	6	40	16	5*	35	100
TSS06065	6	67	30	10	55	100
TSS08050	8	50	22	5*	45	100
TSS08075	8	75	40	10	65	100
TSS08095	8	95	60	30	65	100
TSS08120	8	120	85	55	65	100
TSS10060	10	60	25	10*	50	50
TSS10080	10	85	40	10	70	50
TSS10100	10	105	60	30	70	50
TSS10125	10	125	80	50	70	50
TSS10175	10	175	80	100	70	50
TSS12085	12	95	50	14*	80	25
TSS12100	12	105	60	10	90	25
TSS12115	12	115	70	20	90	25
TSS12145	12	145	100	50	90	25
TSS12200	12	200	100	105	90	25
TSS16110	16	115	60	13*	90	20
TSS16125	16	130	70	10	110	20
TSS16150	16	150	90	30	110	20
TSS16175	16	180	110	60	110	20
TSS20170	20	180	70	35	130	10
TSS20220	20	240	70	95	130	10

* Reduced loading due to shallow embedment

Throughbolt • Hot Dipped Galvanised • EN1461

The throughbolt is a torque controlled anchor suitable for use in concrete over C20/25.



Part Number	Anchor Hole Size mm	Anchor Length mm	Thread Length mm	Max Fixture Thickness mm	Minimum Hole Depth mm	Quantity Per Box
TG08050	8	50	22	5*	45	100
TG08075	8	75	25	10	65	100
TG08095	8	95	25	30	65	100
TG08120	8	120	25	55	65	100
TG10060	10	60	25	10*	50	50
TG10070	10	70	30	20*	50	50
TG10080	10	80	30	10	70	50
TG10100	10	100	30	30	70	50
TG10125	10	125	30	50	70	50
TG12085	12	85	50	10*	70	25
TG12100	12	100	35	5	90	25
TG12115	12	115	35	20	90	25
TG12145	12	145	35	50	90	25
TG12180	12	180	80	85	90	25
TG16110	16	110	40	15*	85	20
TG16125	16	130	40	10	110	20
TG16150	16	150	40	30	110	20
TG16200	16	200	40	80	110	20
TG20170	20	170	45	25	130	10
TG20220	20	220	45	75	130	10
TG20280	20	280	45	135	130	10



Ankerbolts

Ankerbolt • Hexagon Flange Head Zinc Plated and Clear Passivated • Min 5µm



The Ankerbolt is a self tapping anchor for use in a variety of base materials. The self tapping action provides a positive anchorage in concrete, brick, stone and blocks.

Part Number	Anchor Hole Size mm	Anchor Length mm	Max Fixture Thickness mm	Minimum Hole Depth mm	Driver Type	Quantity Per Box
JAB05/06050	5	50	25	35	8mm A/F	100
JAB05/06075	5	75	50	35	8mm A/F	100
JAB05/06100	5	100	75	35	8mm A/F	100
JAB06/08030	6	30	5	35	10mm A/F	100
JAB06/08050	6	50	20	40	10mm A/F	100
JAB06/08075	6	75	45	40	10mm A/F	100
JAB06/08100	6	100	70	40	10mm A/F	100
JAB06/08130	6	130	100	40	10mm A/F	100
JAB06/08150	6	150	120	40	10mm A/F	100



Ankerbolt • Hexagon Head • Zinc Plated and Clear Passivated • Min 5µm

Part Number	Anchor Hole Size mm	Anchor Length mm	Max Fixture Thickness mm	Minimum Hole Depth mm	Driver Type	Quantity Per Box
JAB08/10060	8	60	20	55	15mm A/F	100
JAB08/10075	8	75	35	55	15mm A/F	100
JAB08/10100	8	100	60	55	15mm A/F	100
JAB08/10130	8	130	90	55	15mm A/F	50
JAB08/10150	8	150	110	55	15mm A/F	50
JAB10/12060	10	60	10	70	17mm A/F	50
JAB10/12075	10	75	25	70	17mm A/F	50
JAB10/12100	10	100	50	70	17mm A/F	50
JAB10/12130	10	130	80	70	17mm A/F	25
JAB10/12150	10	150	100	70	17mm A/F	25
JAB12/14075	12	75	15	85	19mm A/F	50
JAB12/14100	12	100	40	85	19mm A/F	50
JAB12/14130	12	130	70	85	19mm A/F	25
JAB12/14150	12	150	90	85	19mm A/F	20
JAB12/14200	12	200	140	85	19mm A/F	20
JAB14/16075	14	75	5	100	24mm A/F	25
JAB14/16100	14	100	30	100	24mm A/F	25
JAB14/16130	14	130	60	100	24mm A/F	20
JAB14/16150	14	150	80	100	24mm A/F	10
JAB14/16200	14	200	130	100	24mm A/F	10
JAB16/18100*	16	100	20	110	27mm A/F	10
JAB16/18150*	16	150	70	110	27mm A/F	10
JAB16/18200*	16	200	120	110	27mm A/F	10

* Mechanical Galvanised • Min 40µm



Ankerbolt • Pan Head • Zinc Plated and Clear Passivated Min 5µm • Torx Drive

Part Number	Anchor Hole Size mm	Anchor Length mm	Max Fixture Thickness mm	Minimum Hole Depth mm	Head Diameter mm	Driver Type	Quantity Per Box
JAB05/06050PH	5	50	25	35	16	T25	100
JAB05/06075PH	5	75	50	35	16	T25	100
JAB05/06100PH	5	100	75	35	16	T25	100
JAB06/08030PH	6	30	5	35	16	T30	100
JAB06/08050PH	6	50	20	40	16	T30	100
JAB06/08075PH	6	75	45	40	16	T30	100
JAB06/08100PH	6	100	70	40	16	T30	100



Countersunk • Zinc Plated and Clear Passivated • Min 5µm

Part Number	Anchor Hole Size mm	Anchor Length mm	Max Fixture Thickness mm	Minimum Hole Depth mm	Head Diameter mm	Driver Type	Quantity Per Box
JAB05/06030CS	5	30	5	35	12.5	T30 Torx	100
JAB05/06050CS	5	50	20	40	12.5	T30 Torx	100
JAB05/06075CS	5	75	45	40	12.5	T30 Torx	100
JAB05/06100CS	5	100	70	40	12.5	T30 Torx	100
JAB06/08030CS	6	30	5	35	12.5	T30 Torx	100
JAB06/08050CS	6	50	20	40	12.5	T30 Torx	100
JAB06/08075CS	6	75	45	40	12.5	T30 Torx	100
JAB06/08100CS	6	100	70	40	12.5	T30 Torx	100
JAB06/08130CS	6	130	100	40	12.5	T30 Torx	100
JAB06/08150CS	6	150	120	40	12.5	T30 Torx	100
JAB08/10060CS	8	60	20	55	17.5	T45 Torx	100
JAB08/10075CS	8	75	35	55	17.5	T45 Torx	100
JAB08/10100CS	8	100	60	55	17.5	T45 Torx	100
JAB10/12060CS	10	60	10	70	22	T50 Torx	50
JAB10/12075CS	10	75	25	70	22	T50 Torx	50
JAB10/12100CS	10	100	50	70	22	T50 Torx	50



Hexagon Flange Head • Mechanical Galvanised • Min 40µm

Part Number	Anchor Hole Size mm	Anchor Length mm	Max Fixture Thickness mm	Minimum Hole Depth mm	Driver Type	Quantity Per Box
JAB06/08050G	6	50	20	40	10mm A/F	100
JAB06/08075G	6	75	45	40	10mm A/F	100
JAB06/08100G	6	100	70	40	10mm A/F	100



Hexagon Head • Mechanical Galvanised • Min 40µm

JAB08/10060G	8	60	20	55	15mm A/F	100
JAB08/10100G	8	100	60	55	15mm A/F	100
JAB08/10150G	8	150	110	55	15mm A/F	50
JAB10/12060G	10	60	10	70	17mm A/F	50
JAB10/12100G	10	100	50	70	17mm A/F	50
JAB10/12150G	10	150	100	70	17mm A/F	25
JAB12/14100G	12	100	40	85	19mm A/F	50
JAB12/14150G	12	150	90	85	19mm A/F	20
JAB12/14200G	12	200	140	85	19mm A/F	20



Option 1 Approved Ankerbolt

An Ankerbolt with an Option 1 European Technical Approval suitable for cracked and non-cracked concrete.



Part Number	Anchor Hole Size mm	Anchor Length mm	Max Fixture Thickness mm	Minimum Hole Depth mm	Driver Type	Quantity Per Box
JAB08/10075ETA	8	75	10	75	15mm A/F	100
JAB08/10100ETA	8	100	35	75	15mm A/F	100
JAB08/10130ETA	8	130	65	75	15mm A/F	50
JAB08/10150ETA	8	150	85	75	15mm A/F	50
JAB10/12100ETA	10	100	25	85	17mm A/F	50
JAB10/12130ETA	10	130	55	85	17mm A/F	25
JAB10/12150ETA	10	150	75	85	17mm A/F	25
JAB12/14100ETA	12	100	5	105	19mm A/F	50
JAB12/14130ETA	12	130	35	105	19mm A/F	25
JAB12/14150ETA	12	150	55	105	19mm A/F	20
JAB12/14200ETA	12	200	105	105	19mm A/F	20
JAB14/16150ETA	14	150	35	125	24mm A/F	10



Ankerbolt • Countersunk Bi-Metal Stainless Steel

A Bi-Metallic A4/316 Stainless Steel Ankerbolt with Carbon Steel tip with leading threads to cut into the concrete.

Part Number	Anchor Hole Size mm	Anchor Length mm	Max Fixture Thickness mm	Minimum Hole Depth mm	Head Diameter mm	Driver Type	Quantity Per Box
JAB06/08050CSSS	6	50	20	40	15	T40	100
JAB06/08075CSSS	6	75	45	40	15	T40	100
JAB06/08100CSSS	6	100	70	40	15	T40	100



Ankerbolt • Hexagon Flange Head Bi-Metal Stainless Steel

A Bi-Metallic A4/316 Stainless Steel Ankerbolt with Carbon Steel tip with leading threads to cut into the concrete.

Part Number	Anchor Hole Size mm	Anchor Length mm	Max Fixture Thickness mm	Minimum Hole Depth mm	Driver Type	Quantity Per Box
JAB06/08050SS	6	50	20	40	10mm A/F	100
JAB06/08075SS	6	75	45	40	10mm A/F	100
JAB06/08100SS	6	100	70	40	10mm A/F	100
JAB08/10060SS	8	60	20	55	13mm A/F	100
JAB08/10075SS	8	75	35	55	13mm A/F	100
JAB08/10100SS	8	100	60	55	13mm A/F	100
JAB10/12075SS	10	75	25	70	17mm A/F	50
JAB10/12100SS	10	100	50	70	17mm A/F	50
JAB10/12150SS	10	150	100	70	17mm A/F	25
JAB12/14100SS	12	100	40	85	19mm A/F	50



Ankerbolt Drop In • Zinc Plated and Clear Passivated • Min 5µm

A self tapping anchor providing a flush internal thread.

Part Number	Anchor Hole Size mm	Anchor Length mm	Minimum Hole Depth mm	Internal Thread mm	Head Diameter mm	Driver Type	Quantity Per Box
JABDBM10	13	32	50	M10	N/A	6mm Hex	100



Ankerbolt Drop In Setting Tool

Part Number	Drive Size	Quantity Per Box
JABDBM10ST	1/2"	1



Socket Bolt • Dual Threaded and Single Thread

Part Number	Anchor Hole Size mm	Anchor Length mm	Minimum Hole Depth mm	Internal Thread mm	Across Flats mm	Quantity Per Box
JAB06/08SOCKET	6	75	50	M8 + M10	17	50
JAB06/08SOCM08	6	55	50	M8	13	100
JAB06/08SOCM10	6	55	50	M10	13	100



Hook Bolt and Eye Hook • Zinc Plated and Clear Passivated • Min 5µm

Part Number	Anchor Hole Size mm	Anchor Length mm	Max. Fixture Thickness mm	Minimum Hole Depth mm	Eye Diameter mm	Quantity Per Box
JAB06/08050HOOK	6	90	N/A	40	13	50
JAB08/10055HOOK	8	90	N/A	45	13	50
JAB06/08050EYE	6	90	N/A	40	13	50
JAB08/10055EYE	8	90	N/A	45	15	50



Torx Drivers

Part Number	Quantity Per Pack
T25	1
T30	1
T40	1
T45	1
T50	1



Sleeve Anchors

Sleeve Anchor • Hexagon Nut • Zinc Plated and Yellow Passivated • Min 5µm



A thin walled sleeve anchor suitable for use in most types of concrete or masonry.

Part Number	Anchor Hole Size mm	Anchor Length mm	Max Fixture Thickness mm	Minimum Hole Depth mm	Quantity Per Box
SLN08040	8	40	5	35	100
SLN08065	8	65	30	40	50
SLN08085	8	80	45	40	50
SLN10050	10	45	5	45	50
SLN10075	10	70	30	45	50
SLN10100	10	95	55	45	50
SLN10125	10	120	80	45	50
SLN12060	12	60	15	50	50
SLN12075	12	70	20	60	50
SLN12100	12	95	50	60	25
SLN12125	12	120	65	60	25
SLN16065	16	65	10	60	25
SLN16110	16	105	50	65	10
SLN16150	16	150	90	65	10
SLN20080	20	75	15	70	10
SLN20110	20	100	45	70	10
SLN20150	20	140	85	70	10

Sleeve Anchor • Hexagon Bolt • Zinc Plated and Yellow Passivated • Min 5µm



A thin walled sleeve anchor suitable for use in most types of concrete or masonry.

Part Number	Anchor Hole Size mm	Anchor Length mm	Max Fixture Thickness mm	Minimum Hole Depth mm	Quantity Per Box
SLB08045	8	40	2	45	100
SLB08070	8	65	25	45	50
SLB08090	8	90	45	45	50
SLB10045	10	45	5	45	50
SLB10055	10	55	15	45	50
SLB10080	10	75	30	50	50
SLB10100	10	95	50	50	50
SLB12065	12	60	5	65	50
SLB12080	12	75	20	65	50
SLB12100	12	95	40	65	25
SLB12125	12	115	65	65	25
SLB16075	16	65	5	65	25
SLB16110	16	100	40	65	10

Sleeve Anchor • Countersunk Head • Phillips No.3 Drive • Zinc Plated and Yellow Passivated • Min 5µm



Part Number	Anchor Hole Size mm	Anchor Length mm	Max Fixture Thickness mm	Minimum Hole Depth mm	Head Diameter mm	Quantity Per Box
SLC08060	8	65	30	40	14	100
SLC08085	8	90	50	40	14	50
SLC10075	10	80	40	45	16	50
SLC10100	10	100	60	45	16	50



Sleeve Anchor • Hexagon Nut • Stainless Steel A4-316

A thin walled sleeve anchor suitable for use in most types of concrete or masonry.

Part Number	Anchor Hole Size mm	Anchor Length mm	Max Fixture Thickness mm	Minimum Hole Depth mm	Quantity Per Box
SLSS06060	6	55	25	35	100
SLSS08040	8	40	5	40	100
SLSS08065	8	65	30	40	50
SLSS10050	10	50	10	45	50
SLSS10075	10	75	35	45	50
SLSS10100	10	95	55	45	50
SLSS12060	12	55	10	50	50
SLSS12075	12	65	20	60	50
SLSS12100	12	95	50	60	25



Sleeve Anchor • Countersunk Head Hex Drive • Stainless Steel A2-304

Part Number	Anchor Hole Size mm	Anchor Length mm	Max Fixture Thickness mm	Minimum Hole Depth mm	Head Diameter mm	Quantity Per Box
SLC08045SS	8	45	8	50	12	100
SLC08060SS	8	60	18	60	12	100
SLC10060SS	10	60	9	60	16	100
SLC10080SS	10	80	19	80	16	100
SLC12070SS	12	70	10	75	20	100
SLC12100SS	12	100	30	100	20	100



Sleeve Anchor • Eye Bolt and Hook Bolt • Zinc Plated and Yellow Passivated • Min 5µm

Part Number	Anchor Hole Size mm	Eye Diameter mm	Minimum Hole Depth mm	Quantity Per Box
Eyebolt - SLZE08040	8	8	45	100
Hookbolt-SLZH08040	8	11	45	100
Forged Eyebolt - SLZE08040F	8	10	45	20



Sleeve Anchor • Eye Bolt • Stainless Steel A2-304

Part Number	Anchor Hole Size mm	Eye Diameter mm	Minimum Hole Depth mm	Quantity Per Box
SLZE08045SS	8	10	50	50
SLZE10060SS	10	11	65	50



Drop In Anchors

Drop In Anchor • Zinc Plated and Yellow Passivated • Min 5µm

The drop in anchor is a deformation controlled anchor suitable for use in concrete over C20/25.



Part Number	Thread Diameter	Anchor Hole Size mm	Anchor Length mm	Minimum Hole Depth mm	Internal Thread Length mm	Quantity Per Box
DBM06	M6	8	25	25	10	100
DBM08	M8	10	30	30	14	100
DBM10	M10	12	40	40	15	50
DBM12	M12	15	50	50	20	50
DBM16	M16	20	65	65	22	25
DBM20	M20	25	80	80	30	25

Lipped Drop In Anchor • Zinc Plated and Yellow Passivated • Min 5µm

Lipped drop in anchors can be accurately set independent of hole depth and can be used in hollow base material applications.



Part Number	Thread Diameter	Anchor Hole Size mm	Anchor Length mm	Minimum Hole Depth mm	Internal Thread Length mm	Quantity Per Box
DBM06SH	M6	8	25	25	10	100
DBM08SH	M8	10	30	30	14	100
DBM10SH	M10	12	30	30	15	50
DBM10SHL	M10	12	40	40	15	50
DBM12SH	M12	15	50	50	20	50
DBM16SH	M16	20	65	65	22	25

ETA Approved Drop In Anchor

A deformation controlled anchor suitable for use in concrete over C20/25.



Part Number	Thread Diameter	Anchor Hole Size mm	Anchor Length mm	Minimum Hole Depth mm	Internal Thread Length mm	Quantity Per Box
ADBM08	M8	10	30	30	13	100
ADBM10	M10	12	40	40	15	50
ADBM12	M12	15	50	50	18	50
ADBM16	M16	20	65	65	23	25



Drop In Anchor • Stainless Steel, Grade A4-316

Part Number	Thread Diameter	Anchor Hole Size mm	Anchor Length mm	Minimum Hole Depth mm	Internal Thread Length mm	Quantity Per Box
DSSM06	M6	8	30	30	11	200
DSSM08	M8	10	30	30	13	100
DSSM10	M10	12	40	40	15	50
DSSM12	M12	15	50	50	19	50
DSSM16	M16	20	65	65	25	25



Drop In Anchor Setting Punches



Part Number	Thread Diameter mm	Anchor Hole Size mm	Anchor Length mm	Minimum Hole Depth mm	Internal Thread Length mm	Quantity Per Box
DZSP06	-	-	-	-	-	1
DZSP08	-	-	-	-	-	1
DZSP10	-	-	-	-	-	1
DZSP12	-	-	-	-	-	1
DZSP16*	-	-	-	-	-	1
DZSP20*	-	-	-	-	-	1

The correct size setting punch must be used to safely install drop in anchors.

* Without hand guard



Hook Bolts

Forged Hook and Eyebolts • Zinc Plated and Clear Passivated Min 5µm

Part Number	Thread Diameter mm	Thread Length mm	Eye Diameter mm	Outside Eye Diameter mm	Quantity Per Box
FHM06	6	50	8	22	50
FHM08	8	60	10	30	50
FHM10	10	73	12	36	25
FHM12	12	90	16	47	10



Eye Bolts

Part Number	Thread Diameter mm	Thread Length mm	Eye Diameter mm	Outside Eye Diameter mm	Quantity Per Box
FEM06	6	50	10	19	50
FEM08	8	60	11	23	50
FEM10	10	73	14	28	25
FEM12	12	90	16	34	10



Scaffold Ring Bolts

Scaffolding ring bolts are used together with M16 drop in anchors or M16 internal threaded sockets for restraining scaffolding.

Part Number	Thread Diameter mm	Eye Diameter mm	Overall Length mm	Quantity Per Box
DSRBM16	16	53	210	1



Scaffold Eye

Part Number	Overall Length mm	Thread Diameter mm	Thread Length mm	Eye Internal Diameter mm	Quantity Per Box
SRE12120	120	12	60	24	20
SRE12160	160	12	60	24	10



Scaffold Eye Plugs

Part Number	Overall Length mm	Drill Diameter mm	Quantity Per Box
SRP14100	100	14	20



Shield Anchors

Shield Only • Zinc Plated and Yellow Passivated • Min

A torque controlled shield anchor suitable for use in concrete and solid brickwork.



Part Number	Thread Diameter	Shield Hole Size mm	Max Fixture Thickness mm	Shield Length mm	Minimum Hole Depth mm	Quantity Per Box
ASHOM06	M6	12	-	45	50	50
ASHOM08	M8	14	-	50	55	50
ASHOM10	M10	16	-	60	65	50
ASHOM12	M12	20	-	75	85	25
ASHOM16	M16	25	-	110	125	10

Shield Only • Stainless Steel Grade A4-316



Part Number	Thread Diameter	Shield Hole Size mm	Max Fixture Thickness mm	Shield Length mm	Minimum Hole Depth mm	Quantity Per Box
PSM06SS	M6	12	-	45	50	25
PSM08SS	M8	14	-	50	55	25
PSM10SS	M10	16	-	60	65	25
PSM12SS	M12	20	-	75	85	10

Projecting Bolt • Zinc Plated and Yellow Passivated • Min 5µm



Part Number	Thread Diameter	Shield Hole Size mm	Max Fixture Thickness mm	Overall Length mm	Minimum Hole Depth mm	Quantity Per Box
APB0610	M6	12	10	60	50	50
APB0625	M6	12	25	75	50	50
APB0650	M6	12	50	100	50	50
APB0815	M8	14	15	75	55	50
APB0840	M8	14	40	100	55	50
APB0880	M8	14	80	140	55	25
APB1010	M10	16	10	80	65	50
APB1030	M10	16	30	100	65	50
APB1050	M10	16	50	120	65	25
APB1070	M10	16	70	140	65	25
APB1215	M12	20	15	100	85	25
APB1225	M12	20	25	110	85	25
APB1250	M12	20	50	135	85	10
APB1270	M12	20	70	155	85	10
APB1635	M16	25	35	160	125	10

Loose Bolt • Zinc Plated and Yellow Passivated • Min 5µm



Part Number	Thread Diameter	Shield Hole Size mm	Max Fixture Thickness mm	Length Under Head mm	Minimum Hole Depth mm	Quantity Per Box
ALB0610	M6	12	10	55	50	50
ALB0625	M6	12	25	70	50	50
ALB0640	M6	12	40	85	50	50
ALB0810	M8	14	10	60	55	50
ALB0825	M8	14	25	75	55	50
ALB0840	M8	14	40	90	55	50
ALB1010	M10	16	10	70	65	50
ALB1025	M10	16	25	85	65	50
ALB1050	M10	16	50	110	65	50
ALB1075	M10	16	75	135	65	25
ALB1210	M12	20	10	85	85	25
ALB1225	M12	20	25	100	85	25
ALB1240	M12	20	40	115	85	25
ALB1260	M12	20	60	135	85	25
ALB1615	M16	25	15	135	125	10
ALB1630	M16	25	30	150	125	10
ALB1660	M16	25	60	180	125	10



Eye Bolts • Zinc Plated and Yellow Passivated • Min 5µm

Part Number	Thread Diameter	Shield Hole Size mm	Eye Diameter mm	Overall Length mm	Quantity Per Box
AEBM06	M6	12	10	80	25
AEBM08	M8	14	11	95	25
AEBM10	M10	16	14	115	10
AEBM12	M12	20	16	130	10



Hook Bolts • Zinc Plated and Yellow Passivated • Min 5µm

Part Number	Thread Diameter	Shield Hole Size mm	Eye Diameter mm	Overall Length mm	Quantity Per Box
AHBM06	M6	12	8	80	25
AHBM08	M8	14	10	95	25
AHBM10	M10	16	12	115	10
AHBM12	M12	20	16	145	10



Heavy Duty Anchors

Heavy Duty Anchor • Hexagon Bolt • Zinc Plated and Clear Passivated • Min 5µm



A torque controlled heavy duty, hex bolt anchor suitable for use in cracked and non-cracked concrete over C20/25.

Part Number	Anchor Hole Size mm	Anchor Length mm	Max Fixture Thickness mm	Minimum Hole Depth mm	Quantity Per Box
JHD0610	10	75	10	65	50
JHD0630	10	95	30	65	50
JHD0650	10	115	50	65	50
JHD0810	12	87	10	80	50
JHD0830	12	107	30	80	25
JHD0850	12	127	50	80	25
JHD1015	15	108	15	95	25
JHD1025	15	118	25	95	25
JHD1045	15	138	45	95	25
JHD1210	18	117	10	105	20
JHD1220	18	127	20	105	20
JHD1240	18	147	40	105	20
JHD1270	18	177	70	105	20
JHD1610	24	132	10	130	10
JHD1620	24	152	20	130	10
JHD1650	24	182	50	130	10
JHD2030	28	192	30	160	10
JHD2060	28	222	60	160	5

Heavy Duty Anchor • Stud & Nut • Zinc Plated and Clear Passivated • Min 5µm



A torque controlled heavy duty, hex nut anchor suitable for use in cracked and non-cracked concrete over C20/25.

Part Number	Anchor Hole Size mm	Anchor Length mm	Max Fixture Thickness mm	Minimum Hole Depth mm	Quantity Per Box
NHD0810	12	90	10	80	50
NHD0830	12	110	30	80	50
NHD0850	12	130	50	80	25
NHD1015	15	111	15	95	25
NHD1025	15	121	25	95	25
NHD1045	15	141	45	95	25
NHD1210	18	122	10	105	20
NHD1220	18	132	20	105	20
NHD1240	18	152	40	105	20
NHD1270	18	182	70	105	20
NHD1620	24	157	20	130	10
NHD1650	24	187	50	130	10

Heavy Duty Anchor • Countersunk • Zinc Plated and Clear Passivated • Min 5µm



A torque controlled heavy duty anchor with a countersunk hex head drive suitable for use in cracked and non-cracked concrete over C20/25.



Part Number	Anchor Hole Size mm	Thread Diameter mm	Anchor Length mm	Max Fixture Thickness mm	Minimum Hole Depth mm	Head Diameter	Quantity Per Box
SLSK10/10	10	6	70	10	65	16.5	50
SLSK10/25	10	6	85	25	65	16.5	50
SLSK10/45	10	6	100	40	65	16.5	50
SLSK12/10	12	8	80	10	80	20.5	50
SLSK12/25	12	8	95	25	80	20.5	50
SLSK12/50	12	8	120	50	80	20.5	25
SLSK15/10	15	10	100	10	95	24.5	25
SLSK15/25	15	10	110	25	95	24.5	25
SLSK15/50	15	10	135	50	95	24.5	25
SLSK18/20	18	12	115	20	105	29.5	20
SLSK18/40	18	12	135	40	105	29.5	20



Heavy Duty Anchor • Stud & Nut • Stainless Steel A4/316

A torque controlled heavy duty, stainless steel, hex nut anchor suitable for use in cracked and non-cracked concrete over C20/25.



Part Number	Anchor Hole Size mm	Thread Diameter mm	Anchor Length mm	Max Fixture Thickness mm	Minimum Hole Depth mm	Quantity Per Box
SLB12/10SS	12	8	89	10	80	50
SLB12/30SS	12	8	109	30	80	50
SLB14/15SS	15	10	110	15	95	25
SLB14/25SS	15	10	120	25	95	25
SLB18/20SS	18	12	131	20	105	20
SLB18/40SS	18	12	151	40	105	20



Injection Resin

Pure Epoxy



Pure Epoxy resin is a 3:1 ratio resin with very high load capacities. The colour of the resin is red. Approved for use in contact with potable (drinking) water.



Part Number	Description	Volume	Quantity Unit/Box
JF375E	Pure Epoxy Resin in Cartridge + 1 Mixer Nozzle	375ml	1/10
JF300E	Pure Epoxy Resin in Cartridge + 1 Mixer Nozzle	300ml	1/12

Vinylester



Pure Vinylester Resin Styrene Free is a high strength resin suitable for use in concrete, brickwork and most natural stone. Approved for use in contact with potable (drinking) water.



Part Number	Description	Volume	Quantity Unit/Box
JFV380SF	Vinylester High Load Resin in Cartridge + 1 Mixer Nozzle	410ml	1/12
JFV300SF	Vinylester High Load Resin in Cartridge + 1 Mixer Nozzle	300ml	1/12

Epoxy Acrylate



Epoxy Acrylate Styrene Free is suitable for use in concrete, other base materials and in damp conditions.



Part Number	Description	Volume	Quantity Unit/Box
JFEA380SF	Grey Styrene Free Epoxy Acrylate + 1 Mixer Nozzle	410ml	1/12



Vinylester Fast Cure Winter Grade

Winter Grade Vinylester Styrene Free Resin can be used in temperatures down to -10°C or as a fast cure resin in warmer temperatures.



Part Number	Description	Volume	Quantity Unit/Box
JFEA410SFW	Winter Grade Resin Styrene Free Vinylester + 1 Mixer Nozzle	410ml	1/12



Polyester Styrene Free

Polyester Styrene Free Resin is a general purpose resin suitable for brickwork, most natural stone and concrete.



Part Number	Description	Volume	Quantity Unit/Box
JF380PSF	Grey Styrene Free Polyester + 1 Mixer Nozzle	410ml	1/12
JFEA300SF	Grey Styrene Free Polyester + 1 Mixer Nozzle	300ml	1/12
JF150P	Grey Styrene Free Polyester + 2 Mixer Nozzle	150ml	1/12



Polyester

Polyester Resin is a general purpose resin suitable for brickwork, most natural stone and concrete.



Part Number	Description	Volume	Quantity Unit/Box
JF380P	Grey Polyester Resin in Cartridge + 1 Mixer Nozzle	410ml	1/12

Resin Fixing Per Cartridge

Thread Diameter mm	Hole Size mm	Hole Depth mm	410ml	375ml	300ml	150ml
M8	10	80	78	71	57	25
M10	12	90	52	48	38	17
M12	14	110	34	31	25	11
M16	18	125	22	20	16	7
M20	22	170	11	10	8	3
M24	26	210	7	6	5	2



Injection Tools

Part Number	Description	
JTOOL380	For any 410ml Cartridge	A
JTOOL300	For any 150ml & 300ml Cartridge	B
JTOOL150	For any 150ml & 300ml Cartridge	C
JTOOL375	For JF375E 375ml Cartridge	D

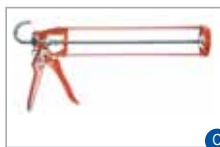

Accessories

Part Number	Description	
JMN130	Mixer Nozzle	A
JMN190	Extension Tube for JMN130	B
JMN150E	Mixer Nozzle for JF375E Pure Epoxy	C

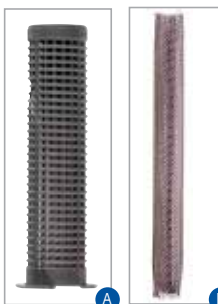

Nylon Sleeve with Stud Alignment Collar

For use with injection resin in hollow bricks and blocks.

Part Number	Hole Diameter mm	Sleeve Size mm	For Stud Size	Quantity Per Bag	
JNSLM08/12	16	15 x 85	M08-M12	10	A
JNSLM08/12L	16	15 x 130	M08-M12	10	
JNSLM16	22	20 x 85	M16	10	



Wire Mesh Sleeve

For use with injection resin. Can be cut on site to required length.

Part Number	Hole Diameter mm	Inside Diameter	For Stud Size	Length mm	Quantity Per Box	
JMMSM08	12	8.7	M8	1000	1	B
JMMSM10/12	16	12.5	M10-M12	1000	1	
JMMSM16	22	18.0	M16	1000	1	
JMMSM20	26	22.0	M20	1000	1	

Cleaning Brushes

Part Number	Hole Diameter mm	Pack Quantity
CB08	8	1
CB10	10	1
CB12	12	1
CB16	16	1
CB20	20	1
CB25	25	1
CBW30	30	1
CBFW25	FLAT	1



Blow Out Pump

Part Number	Hole Diameter mm	Pack Quantity
BOP1	10+	1

Chemical Anchor Studs



J-Fix Studs • Zinc Plated and Clear Passivated •
Min 5µm • Setting Tool Included



Grade 5.8 Threaded Stud.

Part Number	Thread Diameter mm	Length mm	Max Fixture Thickness mm	Minimum Hole Depth mm	Quantity Per Box
JSTUD08110	M8	110	18	80	10
JSTUD10130	M10	130	25	90	10
JSTUD12160	M12	160	34	110	10
JSTUD16190	M16	190	45	125	10
JSTUD20260	M20	260	55	170	10
JSTUD24300	M24	300	55	210	5
JSTUD30380	M30	380	55	280	5

J-Fix Studs • Plain Ended • Zinc Plated and Clear
Passivated • Min 5µm



Grade 5.8 Threaded Stud. For use with injection resin.

Part Number	Thread Diameter mm	Length mm	Max Fixture Thickness mm	Minimum Hole Depth mm	Quantity Per Box
JSTUD08150PE	M8	150	80	60	10
JSTUD10105PE	M10	105	35	60	10
JSTUD10150PE	M10	150	80	60	10
JSTUD10200PE	M10	200	130	60	10
JSTUD12110PE	M12	110	25	70	10
JSTUD12150PE	M12	150	65	70	10
JSTUD12200PE	M12	200	115	70	10
JSTUD16110PE	M16	110	10	80	10
JSTUD16250PE	M16	250	150	80	10
JSTUD16350PE	M16	350	250	80	10
JSTUD20200PE	M20	200	85	90	10
JSTUD20400PE	M20	400	285	90	10



J-Fix Studs • High Tensile Grade 8.8 Zinc Plated and
Yellow Passivated • Min 5µm • Setting Tool Included



Grade 8.8 Threaded Stud.

Part Number	Thread Diameter mm	Length mm	Max Fixture Thickness mm	Minimum Hole Depth mm	Quantity Per Box
JSTUD08110HT	M8	110	18	80	10
JSTUD10130HT	M10	130	25	90	10
JSTUD12160HT	M12	160	34	110	10
JSTUD16190HT	M16	190	45	125	10
JSTUD20260HT	M20	260	55	170	10
JSTUD24300HT	M24	300	55	210	5
JSTUD30380HT	M30	380	55	280	5



J-Fix Studs • Hot Dipped Galvanised • EN1461 • Setting Tool Included



Grade 5.8 Galvanised Threaded Stud.

Part Number	Thread Diameter mm	Length mm	Max Fixture Thickness mm	Minimum Hole Depth mm	Quantity Per Box
JSTUD08110G	M8	110	18	80	10
JSTUD10130G	M10	130	25	90	10
JSTUD12160G	M12	160	34	110	10
JSTUD16190G	M16	190	45	125	10
JSTUD20260G	M20	260	55	170	5
JSTUD24300G	M24	300	55	210	5



J-Fix Studs • Stainless Steel Grade A2/304 • Setting Tool Included

Grade 70 Stainless Steel Threaded Stud. For use with injection resin.

Part Number	Thread Diameter	Length mm	Max Fixture Thickness mm	Minimum Hole Depth mm	Quantity Per Box
JSTUD08110SS	M8	110	18	80	10
JSTUD10130SS	M10	130	25	90	10
JSTUD12160SS	M12	160	34	110	10
JSTUD16190SS	M16	190	45	125	10
JSTUD20260SS	M20	260	55	170	5
JSTUD24300SS	M24	300	55	210	5



J-Fix Studs • Stainless Steel Grade A4/316 • • Setting Tool Included



Grade 70 Stainless Steel Threaded Stud. For use with injection resin.

Part Number	Thread Diameter	Length mm	Max Fixture Thickness mm	Minimum Hole Depth mm	Quantity Per Box
JSTUD08110SSA4	M8	110	18	80	10
JSTUD10130SSA4	M10	130	25	90	10
JSTUD12160SSA4	M12	160	34	110	10
JSTUD16190SSA4	M16	190	45	125	10
JSTUD20260SSA4	M20	260	55	170	5
JSTUD24300SSA4	M24	300	55	210	5



J-Fix Studs • Plain Ended • Stainless Steel Grade A4/316

Grade 70 Stainless Steel Threaded Stud. For use with injection resin.

Part Number	Thread Diameter	Length mm	Max Fixture Thickness mm	Minimum Hole Depth mm	Quantity Per Box
JSTUD08150PESS	M8	150	80	60	10
JSTUD10105PESS	M10	105	35	60	10
JSTUD10150PESS	M10	150	80	60	10
JSTUD10200PESS	M10	200	130	60	10
JSTUD12110PESS	M12	110	25	70	10
JSTUD12150PESS	M12	150	65	70	10
JSTUD12200PESS	M12	200	115	70	10
JSTUD16110PESS	M16	110	10	80	10
JSTUD16250PESS	M16	250	150	80	10
JSTUD16350PESS	M16	350	250	80	10
JSTUD20200PESS	M20	200	85	90	10
JSTUD20400PESS	M20	400	285	90	10

Glass Capsules

J-Fix Spin in Capsules • Epoxy Acrylate
Quartz • Improved Loads



Part Number	Thread Diameter mm	Length mm	Max Fixture Thickness mm	Hole Diameter mm	Minimum Hole Depth mm	Quantity Per Box
JCAPSM08	-	80	-	10	80	10
JCAPSM10	-	80	-	12	90	10
JCAPSM12	-	95	-	14	110	10
JCAPSM16	-	95	-	18	125	10
JCAPSM20	-	160	-	22	170	10
JCAPSM24	-	175	-	26	210	10
JCAPSM30	-	230	-	32	280	5



J-Fix Hammer in Capsules • Epoxy Acrylate

For use with rebar or flat ended studs.

Part Number	Rebar Nominal Diameter mm	Thread Diameter mm	Capsule Diameter mm	Capsule Length mm	Minimum Hole Depth mm	Quantity Per Box
JCAPHM10	10	10	11	90	100	10
JCAPHM12	12	12	13	110	110	10
JCAPHM16	16	16	17	125	125	10
JCAPHM20	20	20	22	175	200	6
JCAPHM24	25	24	24	210	250	6
JCAPHM30	32	30	33	265	300	6

Internal Threaded Sockets

Internal Threaded Sockets • Zinc Plated • Min 5µm

A permanent threaded socket for use with spin in glass capsules or injection resin. Available in either zinc plated carbon steel or stainless steel.



Part Number	Internal Thread Diameter mm	Internal Thread Length mm	Outside Diameter mm	Hole Diameter mm	Anchor Length mm	Minimum Hole Depth mm	Quantity Per Box
ITSM08BZP	M8	30	12	14	90	90	10
ITSM10BZP	M10	35	16	18	90	90	10
ITSM12BZP	M12	40	20	25	90	90	10
ITSM16BZP	M16	40	24	28	125	125	10

Internal Threaded Sockets • Stainless Steel • Grade A2-304

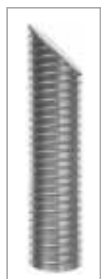

Part Number	Internal Thread Diameter mm	Internal Thread Length mm	Outside Diameter mm	Hole Diameter mm	Anchor Length mm	Minimum Hole Depth mm	Quantity Per Box
ITSM08SS	M8	30	12	14	90	90	10
ITSM10SS	M10	35	16	18	90	90	10
ITSM12SS	M12	40	20	25	90	90	10
ITSM16SS	M16	40	24	28	125	125	10

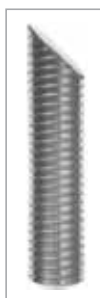

Internal Threaded Sockets • Stainless Steel • Grade A4-316

Part Number	Internal Thread Diameter mm	Internal Thread Length mm	Outside Diameter mm	Hole Diameter mm	Anchor Length mm	Minimum Hole Depth mm	Quantity Per Box
ITSM08SSA4	M8	30	12	14	90	90	10
ITSM10SSA4	M10	35	16	18	90	90	10
ITSM12SSA4	M12	40	20	25	90	90	10
ITSM16SSA4	M16	40	24	28	125	125	10



Injection Resin Internally Threaded Sockets • Zinc Plated • Min 5µm

Part Number	Internal Thread Diameter mm	Internal Thread Length mm	Outside Diameter mm	Hole Diameter mm	Anchor Length mm	Minimum Hole Depth mm	Quantity Per Box
INJM06	M6	20	8	10	50	60	10
INJM08	M8	25	12	14	80	90	10
INJM10	M10	30	14	16	80	90	10
INJM12	M12	30	16	18	80	90	10

Rockite



Rockite (Interior Grade)

Rockite and Kwixset are fast setting hydraulic type cement products. When mixed with water they provide a compound that can be used for grouting, anchoring or patching.

1kg (2.2lb) dry powder weight fills approximately 700 cubic centimeters.

Part Number	Description	Quantity
57 9020	0.45kg (1lb) Cartons	1
57 9002	2.27kg (5lb) Carton	1
57 9003	4.54kg (10lb) Pail	1
57 9004	22.7kg (50lb) Carton	1
57 9005	22.7kg (50lb) Pail	1

Caution: Rockite and Kwixset have very strong expansion properties which generate the high tensile loads that can be achieved and as such their use in hollow bricks or blocks is not recommended.



Kwixset (Exterior Grade)

Part Number	Description	Quantity
57 9011	11.35kg (25lb) Pail	1
57 9012	22.7kg (50lb) Pail	1

Nails and Fixing Bands

Bigtwist Nail • Zinc Plated and Clear Passivated • Min 5µm



A 20mm headed twist nail for fixing composite panels to wooden battens.

Part Number	Shank Diameter mm	Anchor Length mm	Rec.Tensile Load Kn	Max Fixture Thickness mm	Quantity Per Bag/Box
TC08090BG	8	90	0.22	55	25 bag
TC08135BG	8	135	0.22	100	25 bag
TC08165BG	8	165	0.22	130	25 bag
TC08195BG	8	195	0.22	160	25 bag
TC08220BG	8	220	0.22	185	25 bag
TC08090BX	8	90	0.22	55	500 box
TC08135BX	8	135	0.22	100	500 box
TC08165BX	8	165	0.22	130	500 box
TC08195BX	8	195	0.22	160	300 box
TC08220BX	8	220	0.22	185	300 box

Fixing Band

A fixing band for general strapping needs in both straight and round formats. Available in galvanised and A2 stainless steel supplied in rigid plastic dispensers for ease of use.



Galvanised Round Perforated

Part Number	Length Metres	Width mm	Thickness mm	Quantity
FBR1012G	10	12	0.80	1
FBR1017G	10	17	0.80	1



Galvanised Straight Perforated

Part Number	Length Metres	Width mm	Thickness mm	Quantity
FBS1012G	10	12	0.80	1
FBS1019G	10	19	0.80	1



Stainless Steel A2 Round Perforated

Part Number	Length Metres	Width mm	Thickness mm	Quantity
FBR1017SS	10	17	0.80	1





Roof Fixings

Warm Roof Fixings • Stainless Steel A2/304

A helical fixing to secure and sandwich a layer of insulation over the structural roofing timbers.



Part Number	Shank Diameter mm	Anchor Length mm	Max Fixture Thickness mm	Quantity Per Box
WRF06100	6	100	65	100
WRF06110	6	110	75	100
WRF06115	6	115	80	100
WRF06120	6	120	85	100
WRF06125	6	125	90	100
WRF06130	6	130	95	100
WRF06135	6	135	100	100
WRF06140	6	140	105	100
WRF06145	6	145	110	100
WRF06150	6	150	115	100
WRF06160	6	160	125	100
WRF06170	6	170	135	100
WRF06180	6	180	145	100
WRF06190	6	190	155	100
WRF06195	6	195	160	100
WRF06200	6	200	165	100
WRF06205	6	205	170	100



Warm Roof Fixings • Setting Tools

Part Number	Description
WRFSDSST	For use with SDS drills on hammer only
WRFHANST	Hand driven setting tool

Setting tools are recommended for fixings over 120mm long

Crack Stitching Bars & Accessories



Crack Stitch Twist Starter Kit

Part Number	Description
CSKIT	Kit contains 10 lengths of 6mm x 1000mm Bar, 1 x 3ltr Tub of Grout 1 x 9.5mm Nozzle 1 x Crack Stitching Gun 1 x Mixing Paddle 1 x Finger Trowel



Cementitious Grout

Cementitious grout for use in crack stitching.

Part Number	Description
CSGROUT	3 litre tub of grout



C

Crack Filler

For filling cracked masonry and mortar.

Part Number	Description	
JFCSF310	310ml Crack Filler	C

Stitching Bar • Stainless Steel A2-304

1 metre bar for use as masonry reinforcement and crack stitching.

Part Number	Description	Quantity Per Box	
CS061000	6mm x 1000mm bar	10	D
CS081000	8mm x 1000mm bar	10	



E

Stainless Steel Nozzle

Stainless Steel 9.5mm nozzle for use with pointing gun.

Part Number	Description	
CSN095	9.5mm Stainless Steel Nozzle	E



D



F

Pointing Gun

Part Number	Description	
CSGUN	Crack Stitching Gun	F



G

Mixing Paddle

Part Number	Description	
CSMP	Mixing Paddle	G

Finger Trowel

Part Number	Description	
CSFT10	Finger Trowel	H



H



Expanding Foam

B2 & B3 Rated Expanding Foam



B2 foam is suitable for use where joints must conform to BS471 (Part 20) DIN4102 (Part 1) JCP foam is a one part construction foam designed for filling irregular gaps. All foams are supplied with protective gloves included. For B2 Foams to achieve a fire rating approval they must be used in conjunction with a fire rated sealant.

Part Number	Description	Volume	Quantity Unit/Box	
JF750B3H	Grade B3 Hand Held Expanding Foam + 1 Nozzle	750ml	1/12	A
JF750B3G	Grade B3 Gun Applied Expanding Foam	750ml	1/12	B
JF750B2H	Grade B2 Hand Held Foam + 1 Nozzle	750ml	1/12	C
JF750B2G	Grade B2 Gun Applied Foam	750ml	1/12	D
JF500C	Polyurethane Cleaner	500ml	1/12	E
JFGUNC	Professional Applicator Gun	-	1	F
JFGUNB	Conventional Applicator Gun	-	1	G



Fire Stop Expanding Foam

JCP fire stop products can be used where a fire resistance of up to 4 hours is required (according to BS476 part 22).

Part Number	Description	Volume	Quantity Unit/Box	
JF750B1H	Grade B1 Hand Held Expanding Foam + 1 Nozzle	750ml	1/12	E
JF750B1G	Grade B1 Gun Applied Expanding Foam	750ml	1/12	F

Silicone

Intumescent and Acoustic Mastic



Part Number	Description	Volume ml	Quantity Unit/Box
JFIREMAS	Intumescent & Acoustic Mastic	310	1/12

Nylon Products



Hammer Screw • Drive Screw Zinc Plated and Yellow Passivated

A nylon plug with a zinc plated or stainless steel hammer in screw suitable for fixing into concrete or masonry.

Part Number	Anchor Hole Size mm	Anchor Plug Length mm	Max.Fixture Thickness mm	Minimum Hole Depth mm	Quantity Per Box
NHS05030	5	30	5	30	100
NHS05050	5	50	25	30	100
NHS06040	6	40	10	35	100
NHS06050	6	50	20	35	100
NHS06060	6	60	30	35	100
NHS06070	6	70	40	35	100
NHS08060	8	60	20	45	100
NHS08080	8	80	40	45	100
NHS08100	8	100	60	45	50
NHS08120	8	120	80	45	50
NHS08140	8	140	100	45	50



Flange Head Hammer Screw

A nylon plug with a large diameter head, zinc plated hammer in screw suitable for fixing into concrete or masonry.

Part Number	Anchor Hole Size mm	Anchor Plug Length mm	Max.Fixture Thickness mm	Minimum Hole Depth mm	Head Diameter mm	Quantity Per Box
NHS06040FH	6	40	10	35	13	100



Hammer Screw • Drive Screw Stainless Steel A2-304

Part Number	Anchor Hole Size mm	Anchor Plug Length mm	Max.Fixture Thickness mm	Minimum Hole Depth mm	Quantity Per Box
NHS05030SS	5	30	5	30	200
NHS06040SS	6	40	10	35	200
NHS06060SS	6	60	30	35	100
NHS06070SS	6	70	40	35	100
NHS08060SS	8	60	20	45	100
NHS08080SS	8	80	40	45	100
NHS08100SS	8	100	60	45	50

C20/25 Concrete



Nylon Nail Plug

A mushroom head, nylon expansion plug which gives a flush finish with no metallic parts.

Part Number	Anchor Hole Size mm	Anchor Length mm	Max.Fixture Thickness mm	Minimum Hole Depth mm	Head Diameter mm	Box Quantity
NNP06040	6	40	7	50	13	100



Nylon Frame Fixing • Drive Screw Zinc Plated and Yellow Passivated

A nylon plug with a zinc plated screw for fixing into concrete or masonry.

Part Number	Anchor Hole Size mm	Anchor Plug Length mm	Max Fixture Thickness mm	Minimum Hole Depth mm	Quantity Per Box
NFF08060	8	60	20	45	100
NFF08080	8	80	40	45	100
NFF08100	8	100	60	45	100
NFF08120	8	120	80	45	100
NFF10080	10	80	35	50	100
NFF10100	10	100	55	50	100
NFF10120	10	120	75	50	100
NFF10140	10	140	95	50	100
NFF10160	10	160	115	50	100

C20/25 Concrete



Countersunk Nylon Frame Fixing • European Technical Approval to ETAG020-01

A nylon frame fixing with a European Technical Approval for multiple fixings for non-structural applications. Countersunk screw with a Torx drive, 8mm T30 Drive, 10mm T40 Drive.

NFF08080ETA	8	80	10	90	100
NFF08100ETA	8	100	30	90	100
NFF08120ETA	8	120	50	90	100
NFF08140ETA	8	140	70	90	50
NFF10080ETA	10	80	10	90	50
NFF10100ETA	10	100	30	90	50
NFF10120ETA	10	120	50	90	50
NFF10140ETA	10	140	70	90	50
NFF10160ETA	10	160	90	90	50



Hexagonal Head Nylon Frame Fixing • European Technical Approval to ETAG020-01

A nylon frame fixing with a European Technical Approval for multiple fixings for non-structural applications. Hexagonal Head Screw.

NFF08080ETAH	8	80	10	90	100
NFF08100ETAH	8	100	30	90	100
NFF08120ETAH	8	120	50	90	100
NFF08140ETAH	8	140	70	90	50
NFF10080ETAH	10	80	10	90	50
NFF10100ETAH	10	100	30	90	50
NFF10120ETAH	10	120	50	90	50
NFF10140ETAH	10	140	70	90	50
NFF10160ETAH	10	160	90	90	50



Stainless Steel Countersunk Nylon Frame Fixing • European Technical Approval to ETAG020-01

A nylon frame fixing with a European Technical Approval for multiple fixings for non-structural applications. A4 Stainless Steel Countersunk screw with a Torx drive, 8mm T30 Drive, 10mm T40 Drive.

NFF08080ETASS	8	80	10	90	100
NFF08100ETASS	8	100	30	90	100
NFF08120ETASS	8	120	50	90	100
NFF08140ETASS	8	140	70	90	50
NFF10080ETASS	10	80	10	90	50
NFF10100ETASS	10	100	30	90	50
NFF10120ETASS	10	120	50	90	50
NFF10140ETASS	10	140	70	90	50
NFF10160ETASS	10	160	90	90	50



Plug Range



Push Plug

A mushroom head push in fixing with no expansion forces. Grips the hole with flexible wings.

Part Number	Anchor Hole Size mm	Anchor Length mm	Max.Fixture Thickness mm	Minimum Hole Depth mm	Head Diameter mm	Quantity Per Box
PP06035	6	35	5	45	13	100



Nylon Wall Plugs • Suitable for Solid Base Materials

Part Number	Anchor Hole Size mm	Plug Length mm	Wood Screw Gauge No mm	Wood Screw Size mm	Minimum Hole Depth mm	Quantity Per Box
NP05	5	25	4-6	2.5-3.5	30	100
NP06	6	30	6-10	3.5-5.0	35	100
NP07	7	30	8-12	4.0-5.5	35	100
NP08	8	40	10-14	5.0-6.0	45	100
NP10	10	50	14-18	6.0-8.0	55	50
NP12	12	60	18-24	8.0-10.0	70	25
NP14	14	70	24-32	10.0-12.0	80	20



Universal Plugs • Suitable for Hollow or Solid Base Materials

NUP06035	6	35	6-8	3.5-4.0	40	200
NUP08050	8	50	10-12	4.5-5.5	55	100
NUP10060	10	61	12-14	5.5-6.0	65	50



JCP Standard • Plastic Plugs (Sold in outers of 1,000)

Part Number	Colour	Drill Diameter mm	Length mm	Wood Screw Gauge No	Metric Screw Size mm	Minimum Hole Depth	Quantity Per Box
AYP	Yellow	5	22	4-8	2.5-4	30	100
ARP	Red	6	30	6-10	3.5-5	40	100
ABP	Brown	7	37	10-14	5-6	45	100



JCP Premium • Plastic Plugs (Sold in outers of 1,000)

JCPRED	Red	6	37	6-10	3.5-5	45	100
JCPBROWN	Brown	7	37	10-14	5-6	45	100

Metal Expansion Plug

A 4 segment expansion plug expanded by using a wood screw for light duty fixing in to concrete, masonry or aerated concrete blocks.



Part Number	Drill Diameter mm	Plug Length mm	Screw Size mm	Minimum Hole Depth mm	Quantity Per Box
MP05030	5	30	4.5	40	100
MP06032	6	32	4.5-5.0	40	100
MP08038	8	38	5.0-6.0	50	100
MP08060	8	60	5.0-6.0	70	50



Concrete Screws



Concrete Screw • Includes White Cover Cap

A countersunk self tapping screw, zinc plated and yellow passivated, suitable for use in concrete, concrete blocks and masonry. A T30 drive bit supplied in each box of countersunk only.

Part Number	Drill Diameter mm	Screw Length mm	Max Fixture Thickness mm	Minimum Hole Depth mm	Quantity Per Box
CS75040	6	40	-	45	100
CS75060	6	60	20	45	100
CS75080	6	80	40	45	100
CS75100	6	100	60	45	100
CS75120	6	120	80	45	100
CS75150	6	150	110	45	100
CS75180	6	180	140	45	100

C20/25 Concrete



Concrete Screw • Cylindrical Head • Hex Head Drive • 4mm A/F

CS75060CH	6	60	20	45	100
CS75080CH	6	80	40	45	100
CS75100CH	6	100	60	45	100
CS75120CH	6	120	80	45	100
CS75150CH	6	150	110	45	100
CS75180CH	6	180	140	45	100
CS75210CH	6	210	170	45	100

C20/25 Concrete

Flange Clips



Vertical Flange Clip

A high strength clip for fixing suspended wire to steel profiles.

Part Number	Size mm	Min Purlin Gauge mm	Max Purlin Gauge mm	Height mm	Width mm	Quantity Per Box
VFC1	20 x 42	1.60	2.50	42.00	20.00	100

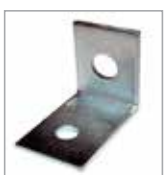

Angle Bracket

A mild steel angle bracket for a variety of applications.

Part Number	Size mm	Width mm	Hole Diameter mm	Thickness mm	Quantity Per Box
AB2020	20 x 20	17.00	4.70	1.20	100



A



B



C

Plug Range

J-Plug • Plasterboard Fixing • C/W Screw

Part Number	Screw Thread Diameter mm	Screw Length mm	Max. Fixture Thickness mm	Hole Depth mm	Quantity Per Box	
JJP15A	4.5	35	15	32	100	A
JJP30A	4.5	50	30	32	100	
JJPN10	4.5	30	10	29	100	B
JJP15	4.5	35	15	37	100	C
JJP30	4.5	50	30	37	100	

J-Plug Plasterboard Kit



Part Number	Description
JJP15ACASE	200 JJP15A Fixings C/W Screws and Screwdriver



Road Fixing Kit

Part Number	Description
RFK12125	4 x M12 x 125 Ankers C/W M12 x 160 Set Bolt & Washer

Ankernut

A synthetic rubber sleeve with brass threaded insert suitable for use in hollow materials and occasional use in solid materials.



Part Number	Thread Diameter mm	Hole Diameter mm	Wall Thickness mm	Overall Length mm	Flange Thickness mm	Flange Diameter mm	Rec. Tightening Torque Nm	Quantity Per Box
LNN03024	3	8	2.0-15.0	24	1.0	11.0	1	50
LNN04011	4	8	0.4-2.0	13	1.0	11.0	1	50
LNN04024	4	8	2.0-15.0	25	1.0	11.0	1	50
LNN05015	5	10	0.4-4.0	14	1.0	13.0	1.8	50
LNN05025	5	10	8.0-16.0	25	1.3	14.0	1.8	50
LNN05040	5	10	20.0-30.0	40	1.3	14.0	1.8	50
LNN06015	6	13	0.4-3.0	15	1.3	16.0	4	50
LNN06025	6	13	6.0-12.0	25	1.3	16.0	4	50
LNN06035	6	13	12.0-25.0	35	1.3	16.0	4	50
LNN06050	6	13	25.0-40.0	50	1.3	16.0	4	50
LNN08025	8	18	4.0-10.0	25	1.3	22.0	8	50
LNN08050	8	18	25.0-35.0	50	1.6	20.0	8	50
LNN10055	10	20	25.0-35.0	55	1.3	22.5	10	25
LNN12075	12	24	35.0-45.0	75	1.3	27.0	15	20
LNN12125	12	24	35.0-45.0	125	1.3	27.0	15	20



Cavity Fixings

Rosett Cavity Fixing • Torx 25 Drive

Part Number	Screw Length mm	Wall Thickness mm	Max. Fixture Thickness mm	Hole Diameter mm	Quantity Per Box
BR05055	55	9-18	15	10	25
BR05080	85	9-18	40	10	25
RR05065	65	18-30	12	10	25
RR05090	90	18-30	38	10	25
BRHOOK	-	9-18	-	10	25
RRHOOK	-	18-30	-	10	25



Hollow Wall Anchor • Zinc Plated and Yellow Passivated

Part Number	Screw Size mm	Wall Thickness mm	Max. Fixture Thickness mm	Hole Diameter mm	Quantity Per Box
LHWA04025	M4 X 25	0-4	10	7	100
LHWA04045	M4 X 45	8-13	15	7	100
LHWA04050	M4 X 50	16-20	15	7	100
LHWA04065	M4 X 65	22-27	30	7	100
LHWA05045	M5 X 45	5-10	15	9	100
LHWA05060	M5 X 60	5-13	23	9	50
LHWA05070	M5 X 70	17-25	23	9	50
LHWA06060	M6 X 60	7-13	23	10	50
LHWA06070	M6 X 70	16-24	24	10	50



Hollow Wall Anchor Setting Tool

Part Number	Quantity Per Box
LHWAST Hand Setting Tool	1

Spring Toggles • Complete with Screws • Zinc Plated and Yellow Passivated



Part Number	Thread Diameter mm	Screw Length mm	Wall & Fixture Thickness mm	Cavity Depth mm	Hole Diameter mm	Quantity Per Box
LST03050	3	50	30	20	11	100
LST05050	5	50	20	30	14	100
LST05075	5	75	45	30	14	100
LST05100	5	100	70	30	14	100
LST06075	6	75	45	30	18	100

Spring Toggles • Wings Only • Zinc Plated and Yellow Passivated

LSTM03	3	-	-	20	11	100
LSTM05	5	-	-	30	14	100
LSTM06	6	-	-	30	18	100
LSTM08	8	-	-	40	22	50
LSTM10	10	-	-	40	25	50

Plastic Toggles



Part Number	Wood Screw Size mm	Wood Screw Gauge mm	Wall Thickness mm	Minimum Cavity Depth mm	Hole Diameter mm	Quantity Per Box
NT10	4.5	8	4-12	30	10	100
NT12	4.5	8	15-19	35	10	100
NT16	4.5	8	24-28	40	10	100

Plug Range

Hammer in fixing available in Steel and Zinc Alloy, suitable for use in concrete, masonry and some natural stone.



Nail In Anchor • Metal

Part Number	Anchor Hole Size mm	Total Anchor Length mm	Max.Fixture Thickness mm	Flange Head Diameter mm	Quantity Per Box
MDA06040	6	40	5	15	100
MDA06065	6	65	30	15	100



Nail In Anchor • Alloy

LANI06030	6	30	10	13	100
LANI06040	6	40	20	13	100
LANI06050	6	50	30	13	100



Nail In Anchor • Steel

MNI06030	6	30	10	13	100
MNI06040	6	40	20	13	100
MNI06050	6	50	30	13	100

Plastic Headed Nails

An A4/316 stainless steel nail, ring shanked with HDPE impact resistant poly head. UV Factor 5 stabilised. Available with white or black heads.



Part Number	Shank Length mm	Shank Diameter mm	Head Colour	Quantity Per Box
POLY030WH	30	2.00	White	250
POLY040WH	40	2.00	White	250
POLY050WH	50	2.65	White	100
POLY065WH	65	3.35	White	100
POLY030BL	30	2.00	Black	250
POLY040BL	40	2.00	Black	250
POLY050BL	50	2.65	Black	100
POLY065BL	65	3.35	Black	100



Masonry Nails

Masonry Nails

Part Number	Length	Shank Diameter mm	Quantity Per Box
LIGHT SHANK			
AMNL025	25	2.5	100
AMNL030	30	2.5	100
AMNL040	40	2.5	100
AMNL050	50	2.5	100
AMNL060	60	2.5	100
MEDIUM SHANK			
AMNM025	25	3.0	100
AMNM030	30	3.0	100
AMNM040	40	3.0	100
AMNM050	50	3.0	100
AMNM060	60	3.0	100
HEAVY SHANK			
AMNH050	50	3.5	100
AMNH060	60	3.5	100
AMNH075	75	3.5	100
AMNH090	90	3.5	100
AMNH100	100	3.5	100



Masonry Nails with 8mm diameter washer

Part Number	Length	Shank Diameter mm	Quantity Per Box
AMNL025MP	25	2.5	200
AMNL030MP	30	2.5	200



Coach Screws and Plugs

Coach screw and plug sets c/w washer

Part Number	Screw Size mm	Plug Size mm	Anchor Hole Diameter	Quantity Per Box
CSP06060	6 x 60	8	8	50
CSP06080	6 x 80	8	8	50
CSP08100	8 x 100	10	10	50
CSP08120	8 x 120	10	10	50



Sanitary Fixings

Basin Fixing

Part Number	Screw Size mm	Plug Size mm	Anchor Hole Diameter	Individual Quantity Per Box
NBFS10140	M10 x 140	14 x 70	14	10



W.C. Fixing

NWCW06070	6.0 x 70	8 x 40	8	50
NWCC06070	6.0 x 70	8 x 40	8	50

Drivefast Gas Nails



Clipped Head Nails + Fuel Cell Pack

34° Angled Nails and gas for timber to timber fixing suitable for use in Drivefast DF90, IM350, NR90GC2, GN900S, WW90CH, GS690CH, GT90CH & D90S. 1 Fuel Cell per 1000 nails.

 CE Marked in accordance with BSEN14592

Part Number	Nail Length mm	Shank Diameter mm	Description	Quantity Per Box
IM35051RB	51	2.8	Ring Bright	2,200
IM35063RB	63	2.8	Ring Bright	2,200
IM35075RB	75	3.1	Ring Bright	2,200
IM35051EG	51	2.8	Ring Electro Galv	2,200
IM35063EG	63	2.8	Ring Electro Galv	2,200
IM35075EG	75	3.1	Ring Electro Galv	2,200
IM35063RG	63	2.8	Ring Hot Dip Galv	2,200
IM35075RG	75	3.1	Ring Hot Dip Galv	2,200
IM35090SB	90	3.1	Smooth Bright	2,200
IM35090EG	90	3.1	Smooth Electro Galv	2,200
IM35090SG	90	3.1	Screwed Electro Galv	2,200



Stainless Steel Ringed Clipped Head Nails + Fuel Cell Pack

IM35051SS	51	2.8	Stainless Steel	1000
IM35063SS	63	2.8	Stainless Steel	1000
IM35080SS	80	3.1	Stainless Steel	1000
IM35090SS	90	3.1	Stainless Steel	1000

Clipped Head Nails + Fuel Cell Pack

Drivefast nails and gas in packs of 1000 nails plus one fuel cell.

Part Number	Nail Length mm	Shank Diameter mm	Description	Quantity Per Box
HAN51RB	51	2.8	Ring Bright	1000
HAN51EG	51	2.8	Ring Electro Galv	1000
HAN63RB	63	2.8	Ring Bright	1000
HAN63EG	63	2.8	Ring Electro Galv	1000
HAN75RB	75	3.1	Ring Bright	1000
HAN75EG	75	3.1	Ring Electro Galv	1000
HAN90SB	90	3.1	Smooth Bright	1000
HAN90SG	90	3.1	Screwed Electro Galv	1000
HAN90EG	90	3.1	Smooth Electro Galv	1000



Brad Nails + Fuel Cell Pack

16 gauge straight brads for use in IM250, NT65GS & DC616KB.
1 Fuel Cell per 1000 nails.



16 Gauge Straight Brads

Part Number	Nail Length mm	Shank Diameter mm	Description	Quantity Per Outer Box	Quantity Per Inner Box
IM25038G	38	F16	IM250 Galv Brad	8000	2000
IM25050G	50	F16	IM250 Galv Brad	8000	2000
IM25064G	64	F16	IM250 Galv Brad	8000	2000

Stainless Steel Brad Nails + Fuel Cell Pack

Part Number	Nail Length mm	Shank Diameter mm	Description	Quantity Per Box
IM25038SS	38	F16	Stainless Steel	2000
IM25050SS	50	F16	Stainless Steel	2000



16 Gauge Angled Brads

Part Number	Nail Length mm	Shank Diameter mm	Description	Quantity Per Outer Box	Quantity Per Inner Box
IM25038A	38	F16	Angled Brad	8000	2000
IM25050A	50	F16	Angled Brad	8000	2000

Drivefast Gas Only

Part Number	Description	Quantity Per Box
IMGAS250	To suit IM250/IM250A	10
IMGAS350	To suit IM350	10

Shot Fired Pins



Metal Washered Pins

Metal Washered Pins suitable for PA97

Part Number	Shank Diameter mm	Shank Length mm	Quantity Per Box
VMW16	3.7	16	100
VMW19	3.7	19	100
VMW22	3.7	22	100
VMW27	3.7	27	100
VMW32	3.7	32	100
VMW37	3.7	37	100
VMW42	3.7	42	100
VMW47	3.7	47	100
VMW52	3.7	52	100
VMW57	3.7	57	100
VMW62	3.7	62	100
VMW72	3.7	72	100
VMW82	3.7	82	100
VMW97	3.7	97	100



Plastic Washered Pins

Plastic Washered Pins suitable for Ramset P.A. Tools, Spit P200 and other 8mm Cartridge tools

VPW16	3.8	16	100
VPW19	3.8	19	100
VPW22	3.8	22	100
VPW27	3.8	27	100
VPW32	3.8	32	100
VPW37	3.8	37	100
VPW42	3.8	42	100
VPW47	3.8	47	100
VPW52	3.8	52	100
VPW57	3.8	57	100
VPW62	3.8	62	100
VPW72	3.8	72	100



Magazine Pins

Magazine Pins suitable for 8mm Magazine Cartridge Tools

VSN19	3.8	19	100
VSN22	3.8	22	100
VSN27	3.8	27	100
VSN32	3.8	32	100
VSN37	3.8	37	100
VSN42	3.8	42	100
VSN47	3.8	47	100
VSN52	3.8	52	100
VSN57	3.8	57	100
VSN62	3.8	62	100
VSN72	3.8	72	100



Ceiling Hanger

Suspension Clip suitable for 8mm Cartridge Tools

Part Number	Shank Diameter mm	Shank Length mm	Quantity Per Box
VCH32	3.8	32	100



Cartridge Tools

Strip Feed Tool with power adjuster suitable for 12mm metal washered drive pins up to 97mm long. (82mm & 97mm pins require pre-driving).

PA97

Part Number	Description	Quantity Per Unit
PA97KIT	Strip Feed Cartridge Tool CW Kit in Toolbox	1

Tool Kit PA97

Part Number	Description	Quantity Per Unit
SG	Safety Goggles	1
DFL0114	Lubricating Spray	1
CBW30	30mm Round Wire Brush	1
CB08	8mm Round Nylon Brush	1
CBFW25	Flat Wire Brush	1
SP703	Piston	1
SP735	Stop Ring	1
SP757	Retaining Ring	1
SP738	Circlip	1
SP771	Spall Shield	1

 CE Marked in accordance with BSEN15895

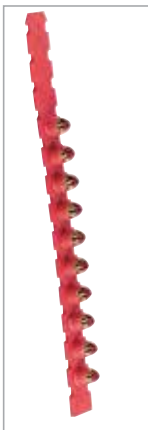

Cartridge Tools

To suit PA97 and most other strip feed tools.

Part Number	Colour	Strength	Quantity Per Box
V3LVS27G	Green	Low	100
V4LVS27Y	Yellow	Low/Medium	100
V6REDLVS27	Red	Medium/High	100
V7BLKLVS27	Black	Extra High	100

Self Drilling Screws



Metalfix • Zinc Plated Min 8µm Steel to Steel without Washer

Part Number	Thread Diameter mm	Length mm	Point Type	Steel Thickness mm	Max. Fixture Thickness mm	Washer Diameter mm	Quantity Per Box
MFL55019	5.5	19	3	1.2-3.0	4	-	100
MFL55025	5.5	25	3	1.2-3.0	10	-	100
MFL55032	5.5	32	3	1.2-3.0	17	-	100
MFL55038	5.5	38	3	1.2-3.0	23	-	100
MFL55050	5.5	50	3	1.2-3.0	35	-	100
MFH55022	5.5	22	4	3.0-6.0	5	-	100
MFH55032	5.5	32	5	4.0-12.5	5	-	100
MFH55040	5.5	40	5	4.0-12.5	13	-	100
MFH55050	5.5	50	5	4.0-12.5	23	-	100
MFH55060	5.5	60	5	4.0-12.5	33	-	100
MFH55070	5.5	70	5	4.0-12.5	43	-	100
MFH55080	5.5	80	5	4.0-12.5	53	-	100



Metalfix • Zinc Plated Min 8µm Steel to Steel with 16mm Washer

MFL55025W16	5.5	25	3	1.2-3.0	7	16	100
MFL55032W16	5.5	32	3	1.2-3.0	14	16	100
MFL55038W16	5.5	38	3	1.2-3.0	20	16	100
MFL55043W16	5.5	43	3	1.2-3.0	25	16	100
MFL55050W16	5.5	50	3	1.2-3.0	32	16	100
MFL55057W16	5.5	57	3	1.2-3.0	39	16	100
MFL55070W16	5.5	70	3	1.2-3.0	52	16	100
MFL55075W16	5.5	75	3	1.2-3.0	57	16	100
MFH55022W16	5.5	22	4	3.0-6.0	2	16	100
MFH55032W16	5.5	32	5	4.0-12.5	2	16	100
MFH55040W16	5.5	40	5	4.0-12.5	10	16	100
MFH55050W16	5.5	50	5	4.0-12.5	20	16	100
MFH55060W16	5.5	60	5	4.0-12.5	30	16	100
MFH55070W16	5.5	70	5	4.0-12.5	40	16	100
MFH55080W16	5.5	80	5	4.0-12.5	50	16	100
MFH55100W16	5.5	100	5	4.0-12.5	70	16	100
MFH55120W16	5.5	120	5	4.0-12.5	90	16	100



Metalfix • Zinc Plated Min 8µm Steel to Steel with 19mm Washer

MFL55025W19	5.5	25	3	1.2-3.0	7	19	100
MFL55032W19	5.5	32	3	1.2-3.0	14	19	100
MFL55038W19	5.5	38	3	1.2-3.0	20	19	100
MFL55050W19	5.5	50	3	1.2-3.0	32	19	100
MFL55075W19	5.5	75	3	1.2-3.0	57	19	100
MFH55022W19	5.5	22	4	3.0-6.0	1.2	19	100
MFH55032W19	5.5	32	5	4.0-12.5	2	19	100
MFH55040W19	5.5	40	5	4.0-12.5	10	19	100
MFH55050W19	5.5	50	5	4.0-12.5	20	19	100
MFH55060W19	5.5	60	5	4.0-12.5	30	19	100
MFH55070W19	5.5	70	5	4.0-12.5	40	19	100
MFH55080W19	5.5	80	5	4.0-12.5	50	19	100
MFH55100W19	5.5	100	5	4.0-12.5	70	19	100
MFH55120W19	5.5	120	5	4.0-12.5	90	19	100



Metalfix • Zinc Plated Min 8µm Steel to Steel without Washer • 1/4" A/F

Part Number	Thread Diameter mm	Length mm	Point Type	Steel Thickness mm	Max. Fixture Thickness mm	Washer Diameter mm	Quantity Per Box
GP42013	4.2	13	2	1.2-2.5	5	-	200
GP42016	4.2	16	2	1.2-2.5	8	-	200
GP42019	4.2	19	2	1.2-2.5	11	-	200
GP42025	4.2	25	2	1.2-2.5	17	-	200
GP48016	4.8	16	3	1.2-3.0	2	-	100
GP48019	4.8	19	3	1.2-3.0	5	-	100
GP48025	4.8	25	3	1.2-3.0	11	-	100



Metalfix Loose Washer • 1mm Steel with 2mm Bonded EPDM Washers

MFW16	6	-	-	-	-	16	100
MFW19	6	-	-	-	-	19	100



Pozi Pan Head Self Drilling Screws • Zinc Plated Min 8µm Steel to Steel

PH35095	3.5	9.5	2	1.2-2.5	1	-	200
PH35013	3.5	13	2	1.2-2.5	5	-	200
PH35019	3.5	19	2	1.2-2.5	11	-	200
PH42013	4.2	13	2	1.2-2.5	5	-	200
PH42016	4.2	16	3	1.2-2.5	8	-	200
PH42019	4.2	19	3	1.2-2.5	11	-	200
PH42025	4.2	25	3	1.2-2.5	17	-	200
PH48013	4.8	13	3	1.2-3.0	2	-	200
PH48019	4.8	19	3	1.2-3.0	5	-	200
PH48025	4.8	25	3	1.2-3.0	11	-	200



Woodfix • Zinc Plated Min 8µm Timber to Steel Phillips No.3 Drive

WFL55040	5.5	40	3	1.2-3.0	22	-	100
WFL55050	5.5	50	3	1.2-3.0	32	-	100
WFL55060	5.5	60	3	1.2-3.0	42	-	100
WFL55080	5.5	80	3	1.2-3.0	62	-	100
WFL55100	5.5	100	3	1.2-3.0	82	-	100
WFL55110	5.5	100	3	1.2-3.0	92	-	100
WFL55120	5.5	120	3	1.2-3.0	112	-	100
WFH55050	5.5	50	5	4.0-12.5	23	-	100
WFH55060	5.5	60	5	4.0-12.5	33	-	100
WFH55070	5.5	70	5	4.0-12.5	43	-	100
WFH55085	5.5	85	5	4.0-12.5	58	-	100
WFH55109	5.5	109	5	4.0-12.5	82	-	100
WFH55120	5.5	120	5	4.0-12.5	92	-	100



Woodfix • Phillips No.3 Drive Bit

Part Number	Thread Diameter mm	Length mm	Point Type	Steel Thickness mm	Max. Fixture Thickness mm	Washer Diameter mm	Quantity Per Box
WFPH3	-	-	-	-	-	-	10

Metalfix Gash Point Screw • Zinc Plated Min 8µm Steel to Timber with Washer



Part Number	Thread Diameter mm	Length mm	Point Type	Steel Thickness mm	Max. Fixture Thickness mm	Washer Diameter mm	Quantity Per Box
GP6303216W	6.3	32	-	0.7-1.4	1	16	100
GP6304516W	6.3	45	-	0.7-1.4	5	16	100
GP6306016W	6.3	60	-	0.7-1.4	15	16	100
GP6308016W	6.3	80	-	0.7-1.4	35	16	100
GP6310016W	6.3	100	-	0.7-1.4	55	16	100
GP6312516W	6.3	125	-	0.7-1.4	80	16	100
GP6302519W	6.3	25	-	0.7-1.4	1	19	100
GP6303219W	6.3	32	-	0.7-1.4	1	19	100
GP6304519W	6.3	45	-	0.7-1.4	5	19	100
GP6306019W	6.3	60	-	0.7-1.4	15	19	100
GP6308019W	6.3	80	-	0.7-1.4	35	19	100
GP6310019W	6.3	100	-	0.7-1.4	55	19	100
GP6312519W	6.3	125	-	0.7-1.4	80	19	100
GP6315019W	6.3	150	-	0.7-1.4	105	19	100

Metalfix Stitching Screw • Zinc Plated Min 8µm Steel to Steel with Washer



SS63022W16	6.3	22	1	-	2 x 0.9	16	100
SS63025W16	6.3	25	1	-	2 x 1.2	16	100
SS63022W19	6.3	22	1	-	2 x 0.9	19	100
SS63025W19	6.3	25	1	-	2 x 1.2	19	100

Maximum Fixture Thickness allows for maximum steel thickness

Metalfix High Thread • Zinc Plated Min 8µm Composite Panel Fixing to Light Section



Part Number	Thread Diameter mm	Length mm	Point Type	Steel Thickness mm	Insulation Thickness mm	Washer Diameter mm	Quantity Per Box
HT55065	5.5	65	3	1.2-3.0	30-45	19	100
HT55070	5.5	70	3	1.2-3.0	35-50	19	100
HT55075	5.5	75	3	1.2-3.0	40-55	19	100
HT55085	5.5	85	3	1.2-3.0	40-60	19	100
HT55100	5.5	100	3	1.2-3.0	45-75	19	100
HT55125	5.5	125	3	1.2-3.0	75-100	19	100
HT55150	5.5	150	3	1.2-3.0	90-120	19	100

Metalfix High Thread • Zinc Plated Min 8µm Composite Panel Fixing to Heavy Section



HTH55075	5.5	75	5	4.0-12.5	30-45	19	100
HTH55105	5.5	105	5	4.0-12.5	50-64	19	100
HTH55130	5.5	130	5	4.0-12.5	60-95	19	100

Wafer Head Screw • No 2 Phillips Drive



Part Number	Thread Diameter mm	Length mm	Point Type	Steel Thickness mm	Insulation Thickness mm	Head Diameter mm	Quantity Per Box
WH4213	4.2	13	2	1.2-2.5	7	11	200



Metalfix • 5/6" Magnetic Socket

Part Number	Thread Diameter mm	Length mm	Point Type	Steel Thickness mm	Insulation Thickness mm	Head Diameter mm	Quantity Per Box
MF516	-	-	-	-	-	-	1



Fibre Cement Screws • Zinc Plated Min 8µm Light Section

Part Number	Thread Diameter mm	Length mm	Point Type	Steel Thickness mm	Max. Fixture Thickness mm	Washer Diameter mm	Quantity Per Box
FCL63110	6.3	110	3	1.2-3.0	75	22/25	50
FCL63125	6.3	125	3	1.2-3.0	95	22/25	50
FCL63155	6.3	155	3	1.2-3.0	125	22/25	50
FCL63175	6.3	175	3	1.2-3.0	145	22/25	50
FCL63195	6.3	195	3	1.2-3.0	165	22/25	50
FCL63230	6.3	230	3	1.2-3.0	200	22/25	50



Fibre Cement Screws • Zinc Plated Min 8µm Heavy Section

Part Number	Thread Diameter mm	Length mm	Point Type	Steel Thickness mm	Max. Fixture Thickness mm	Washer Diameter mm	Quantity Per Box
FCH63110	6.3	110	5	4.0-12.5	75	22/25	50
FCH63130	6.3	130	5	4.0-12.5	95	22/25	50
FCH63150	6.3	150	5	4.0-12.5	120	22/25	50
FCH63180	6.3	180	5	4.0-12.5	145	22/25	50
FCH63200	6.3	200	5	4.0-12.5	165	22/25	50
FCH63235	6.3	235	5	4.0-12.5	200	22/25	50



Metalfix • Bi-Metallic A2 Stainless Steel to Steel Light Section

Part Number	Thread Diameter mm	Length mm	Point Type	Steel Thickness mm	Max. Fixture Thickness mm	Washer Diameter mm	Quantity Per Box
MFL55022SS	5.5	22	3	1.3-3.0	2	-	100
MFL55025SS	5.5	25	3	1.3-3.0	7	-	100
MFL55032SS	5.5	32	3	1.3-3.0	14	-	100
MFL55038SS	5.5	38	3	1.3-3.0	20	-	100
MFL55050SS	5.5	50	3	1.3-3.0	32	-	100



Metalfix • Bi-Metallic A2 Stainless Steel to Steel Heavy Section

Part Number	Thread Diameter mm	Length mm	Point Type	Steel Thickness mm	Max. Fixture Thickness mm	Washer Diameter mm	Quantity Per Box
MFH55032SS	5.5	32	5	4.0-12.5	2	-	100
MFH55038SS	5.5	38	5	4.0-12.5	8	-	100
MFH55050SS	5.5	50	5	4.0-12.5	20	-	100



Metalfix Loose Washer • 1mm A2 Stainless Steel with 2mm Bonded EPDM Washers

Part Number	Hole Diameter mm	Length mm	Point Type	Steel Thickness mm	Max. Fixture Thickness mm	Washer Diameter mm	Quantity Per Box
MFW16SS	6	-	-	-	-	16	100
MFW19SS	6	-	-	-	-	19	100



Metalfix • Light Section Bi-Metallic A2 Stainless Steel 16mm Washer

Part Number	Thread Diameter mm	Length mm	Point Type	Steel Thickness mm	Max. Fixture Thickness mm	Washer Diameter mm	Quantity Per Box
MFL55022SSW16	5.5	22	3	1.2-3.0	2	16	100
MFL55025SSW16	5.5	25	3	1.2-3.0	7	16	100
MFL55032SSW16	5.5	32	3	1.2-3.0	14	16	100
MFL55038SSW16	5.5	38	3	1.2-3.0	20	16	100
MFL55050SSW16	5.5	50	3	1.2-3.0	32	16	100



Metalfix • Bi-Metallic A2 Stainless Steel to Steel Heavy Section

MFH55032SSW16	5.5	32	5	4.0-12.5	2	16	100
MFH55038SSW16	5.5	38	5	4.0-12.5	8	16	100
MFH55050SSW16	5.5	50	5	4.0-12.5	20	16	100



Woodfix • Bi-Metallic A2 Stainless Steel Timber to Steel Phillips Light Section

Part Number	Thread Diameter mm	Length mm	Point Type	Steel Thickness mm	Max. Fixture Thickness mm	Washer Diameter mm	Quantity Per Box
WFL55040SS	5.5	40	3	1.2-3.0	22	-	100
WFL55050SS	5.5	50	3	1.2-3.0	32	-	100
WFL55060SS	5.5	60	3	1.2-3.0	42	-	100
WFL55080SS	5.5	80	3	1.2-3.0	62	-	100



Metalfix Stitching Screw • Bi-Metallic A2 Stainless Steel

Part Number	Thread Diameter mm	Length mm	Point Type	Steel Thickness mm	Max. Fixture Thickness mm	Washer Diameter mm	Quantity Per Box
SS63025SSW16	6.3	25	1	-	2 x 0.9	16	100
SS63035SSW16	6.3	35	1	-	2 x 1.2	16	100



Coloured Cover Caps

Coloured Cover Caps to suit Hexagon Head Self Drilling Screws with 16mm or 19mm washers

Part Number 16mm Washer	Part Number 19mm Washer	Description	Quantity Per Bag
MFC16MG	MFC19MG	Merlin Dark Grey (18B25)	1000
MFC16GG	MFC19GG	Goosewing Light Grey (10A05)	1000
MFC16VB	MFC19VB	Vandyke Brown (08B29)	1000
MFC16OG	MFC19OG	Olive Green (12B27)	1000
MFC16WH	MFC19WH	White (00E55)	1000
MFC16MU	MFC19MU	Mushroom (10B19)	1000
MFC16MO	MFC19MO	Moorland Green (12B21)	1000
MFC16OB	MFC19OB	Ocean Blue (18C39)	1000
MFC16JG	MFC19JG	Juniper Green (12B29)	1000
MFC16BL	MFC19BL	Black (00E53)	1000
MFC16SB	MFC19SB	Slate Blue (18B29)	1000



Metalfix • Vertical Hanger Light Section

An internally threaded socket for hanging rods vertically in light section steel

Part Number	Thread Diameter	Length	Point Type	Steel Thickness	Socket Diameter	A/F	Quantity Per Box
MFL55M0825V	1/4"	25	3	1.2-3.0	M08	5/8"	100
MFL55M0838V	1/4"	38	3	1.2-3.0	M08	5/8"	100
MFL55M1025V	1/4"	25	3	1.2-3.0	M10	5/8"	100
MFL55M1038V	1/4"	38	3	1.2-3.0	M10	5/8"	100



Metalfix • Vertical Hanger Heavy Section

An internally threaded socket for hanging rods vertically in heavy section steel

MFH55M1032V	12g	38	5	4.0-12.5	M10	100	3.60
-------------	-----	----	---	----------	-----	-----	------



Metalfix • Horizontal Hanger Light Section

An internally threaded socket for hanging rods horizontally in light section steel

Part Number	Thread Diameter	Length	Point Type	Steel Thickness	Socket Diameter	A/F	Quantity Per Box
MFL55M0825H	1/4"	25	3	1.2-3.0	M08	5/8"	100
MFL55M1025H	1/4"	25	3	1.2-3.0	M10	5/8"	100
MFL55M1038H	1/4"	38	3	1.2-3.0	M10	5/8"	100



Metalfix • Horizontal Hanger Heavy Section

An internally threaded socket for hanging rods horizontally in heavy section steel

MFH55M1032H	12g	38	5	4.0-12.5	M10	5/8"	100
-------------	-----	----	---	----------	-----	------	-----



Gash Point • Vertical Hanger

An internally threaded socket for hanging rods vertically in wood

Part Number	Thread Diameter	Length	Point Type	Steel Thickness	Socket Diameter	A/F	Quantity Per Box
GP63M0825V	1/4"	25	-	0.7-1.4	M08	5/8"	100
GP63M0850V	1/4"	50	-	0.7-1.4	M08	5/8"	100
GP63M1025V	1/4"	25	-	0.7-1.4	M10	5/8"	100
GP63M1050V	1/4"	50	-	0.7-1.4	M10	5/8"	100
GP79M1063V	5/16"	63	-	0.7-1.4	M10	5/8"	100



Gash Point • Horizontal Hanger

An internally threaded socket for hanging rods horizontally in wood

GP63M0825H	1/4"	25	-	0.7-1.4	M08	5/8"	100
GP63M1025H	1/4"	25	-	0.7-1.4	M10	5/8"	100
GP63M1050H	1/4"	50	-	0.7-1.4	M10	5/8"	100



Setting Tool for Rod Hanger

5/8" socket drive for setting rod hangers

MF508RH							5
---------	--	--	--	--	--	--	---

Drill Bits



SDS+ Drill Bits

Part Number	Diameter mm	Working Length mm	Overall Length mm
SD04110	4.0	50	110
SD05110	5.0	50	110
SD05160	5.0	100	160
SD55110	5.5	50	110
SD55160	5.5	100	160
SD55210	5.5	150	210
SD06110	6.0	50	110
SD06160	6.0	100	160
SD06200	6.0	150	200
SD06260	6.0	200	260
SD65110	6.5	50	110
SD65160	6.5	100	160
SD65210	6.5	150	210
SD65250	6.5	200	250
SD07110	7.0	50	110
SD07160	7.0	100	160
SD07210	7.0	150	210
SD08110	8.0	50	110
SD08160	8.0	100	160
SD08210	8.0	150	210
SD10110	10.0	50	110
SD10160	10.0	100	160
SD10210	10.0	150	210
SD10260	10.0	200	260
SD10450	10.0	400	450
SD12160	12.0	100	160
SD12210	12.0	150	210
SD12260	12.0	200	260
SD12450	12.0	400	450

Part Number	Diameter mm	Working Length mm	Overall Length mm
SD13160	13.0	100	160
SD13210	13.0	150	210
SD13260	13.0	200	260
SD14160	14.0	100	160
SD14210	14.0	150	210
SD14300	14.0	250	300
SD14450	14.0	400	450
SD15160	15.0	100	160
SD15260	15.0	200	260
SD16210	16.0	150	210
SD16300	16.0	250	300
SD16450	16.0	400	450
SD18200	18.0	150	200
SD18450	18.0	400	450
SD20200	20.0	150	200
SD20300	20.0	250	300
SD20450	20.0	400	450
SD22250	22.0	200	250
SD22450	22.0	400	450
SD24260	24.0	200	260
SD24450	24.0	400	450
SD25250	25.0	200	250
SD25450	25.0	400	450
SD26450	26.0	400	450
SD28450	28.0	400	450
SD30450	30.0	400	450

SDS Max Drill Bits



Part Number	Diameter mm	Working Length mm	Overall Length mm
MAX12340	12.0	188	340
MAX12540	12.0	388	540
MAX13340	13.0	188	340
MAX13540	13.0	388	540
MAX14340	14.0	188	340
MAX14540	14.0	388	540
MAX14690	14.0	538	690
MAX15340	15.0	188	340
MAX15540	15.0	388	540
MAX16340	16.0	188	340
MAX16540	16.0	388	540
MAX16690	16.0	538	690
MAX18340	18.0	188	340
MAX18540	18.0	388	540
MAX20370	20.0	218	370
MAX20520	20.0	368	520
MAX20920	20.0	768	920
MAX22370	22.0	218	370
MAX22520	22.0	368	520
MAX22920	22.0	768	920

Part Number	Diameter mm	Working Length mm	Overall Length mm
MAX24370	24.0	218	370
MAX24520	24.0	368	520
MAX25320	25.0	168	320
MAX25520	25.0	368	520
MAX25920	25.0	768	920
MAX26370	26.0	218	370
MAX26520	26.0	368	520
MAX28370	28.0	218	370
MAX28570	28.0	418	570
MAX30370	30.0	218	370
MAX30570	30.0	418	570
MAX32370	32.0	218	370
MAX32570	32.0	418	570
MAX32920	32.0	768	920
MAX35570	35.0	418	570
MAX38570	38.0	418	570
MAX40570	40.0	418	570



SDS+ High Performance Drill Bits • F8 Extreme



Part Number	Diameter mm	Working Length mm	Overall Length mm
SDHP05110	5	50	110
SDHP05160	5	100	160
SDHP55110	5.5	50	110
SDHP55160	5.5	100	160
SDHP06110	6	50	110
SDHP06160	6	100	160
SDHP06210	6	150	210
SDHP06260	6	200	260
SDHP65210	6.5	150	210
SDHP65260	6.5	200	260
SDHP07110	7	50	110
SDHP07160	7	100	160
SDHP08110	8	50	110
SDHP08160	8	100	160
SDHP08210	8	150	210
SDHP10110	10	50	110
SDHP10160	10	100	160
SDHP10210	10	150	210
SDHP10260	10	200	260
SDHP10450	10	400	450

Part Number	Diameter mm	Working Length mm	Overall Length mm
SDHP12160	12	100	160
SDHP12210	12	150	210
SDHP12260	12	200	260
SDHP12450	12	400	450
SDHP14160	14	100	160
SDHP14210	14	150	210
SDHP14310	14	250	310
SDHP15160	15	100	160
SDHP16210	16	150	210
SDHP16310	16	250	310
SDHP16450	16	400	450
SDHP18250	18	200	250
SDHP18450	18	400	450
SDHP20250	20	200	250
SDHP20400	20	350	400
SDHP22250	22	200	250
SDHP22450	22	400	450

Suitable for drilling reinforced concrete

Masonry Drill Bits • Straight Shank



Part Number	Diameter mm	Working Length mm	Overall Length mm
JMD04085	4.0	50	85
JMD05085	5.0	50	85
JMD05150	5.0	90	150
JMD55100	5.5	60	100
JMD55150	5.5	90	150
JMD06100	6.0	60	100
JMD06150	6.0	90	150
JMD65100	6.5	60	100
JMD65150	6.5	90	150
JMD07100	7.0	60	100
JMD07150	7.0	90	150
JMD08120	8.0	80	120
JMD08150	8.0	90	150
JMD08200	8.0	140	200
JMD08300	8.0	240	300
JMD10120	10.0	80	120
JMD10150	10.0	90	150
JMD10200	10.0	140	200
JMD10300	10.0	240	300
JMD10400	10.0	300	400

Part Number	Diameter mm	Working Length mm	Overall Length mm
JMD12150	12.0	90	150
JMD12200	12.0	140	200
JMD12300	12.0	240	300
JMD12400	12.0	300	400
JMD14150	14.0	90	150
JMD14200	14.0	140	200
JMD14400	14.0	300	400
JMD16150	16.0	90	150
JMD16200	16.0	140	200
JMD16300	16.0	240	300
JMD16400	16.0	300	400
JMD18200	18.0	140	200
JMD20160	20.0	100	160
JMD20200	20.0	140	200
JMD20300	20.0	240	300
JMD20400	20.0	300	400
JMD25160	25.0	100	160
JMD25200	25.0	140	200
JMD25300	25.0	240	300
JMD25400	25.0	300	400



Flat Wood Bits

Part Number	Diameter mm	Overall Length mm
FW06	6	158
FW08	8	158
FW10	10	158
FW12	12	158
FW13	13	158
FW14	14	158
FW16	16	158
FW18	18	158
FW19	19	158
FW20	20	158
FW22	22	158
FW24	24	161
FW25	25	161
FW28	28	161
FW30	30	174
FW32	32	174
FW35	35	174
FW38	38	174



Centre Spur Wood Bits

Part Number	Diameter mm	Overall Length mm
TP03	3	60
TP04	4	70
TP05	5	85
TP06	6	90
TP07	7	105
TP08	8	110
TP09	9	115
TP10	10	120
TP12	12	140

HSS • High Speed Steel Drill Bits • Metric



Part Number	Diameter mm	Overall Length mm	Pack Quantity
HSS010	1.0	34	10
HSS015	1.5	40	10
HSS016	1.6	43	10
HSS020	2.0	49	10
HSS022	2.2	53	10
HSS024	2.4	57	10
HSS025	2.5	57	10
HSS026	2.6	57	10
HSS028	2.8	61	10
HSS030	3.0	61	10
HSS032	3.2	65	10
HSS033	3.3	65	10
HSS034	3.4	70	10
HSS035	3.5	70	10
HSS036	3.6	70	10
HSS038	3.8	75	10
HSS040	4.0	75	10
HSS042	4.2	75	10
HSS045	4.5	80	10
HSS048	4.8	86	10
HSS050	5.0	86	10
HSS052	5.2	86	10
HSS055	5.5	93	10
HSS058	5.8	93	10
HSS060	6.0	93	10

Part Number	Diameter mm	Overall Length mm	Pack Quantity
HSS062	6.2	101	10
HSS064	6.4	101	10
HSS065	6.5	101	10
HSS066	6.6	101	10
HSS068	6.8	109	10
HSS070	7.0	109	10
HSS072	7.2	109	10
HSS075	7.5	109	10
HSS078	7.8	117	10
HSS080	8.0	117	10
HSS082	8.2	117	10
HSS085	8.5	117	10
HSS088	8.8	125	10
HSS090	9.0	125	10
HSS094	9.4	125	10
HSS095	9.5	125	10
HSS098	9.8	133	10
HSS100	10.0	133	5
HSS102	10.2	133	5
HSS105	10.5	133	5
HSS110	11.0	142	5
HSS115	11.5	142	5
HSS120	12.0	151	5
HSS125	12.5	151	5
HSS130	13.0	151	5





HSS • High Speed Steel Drill Bits • Imperial



Part Number	Diameter inches	Overall Length mm	Pack Quantity
HSSI00116	1/16	43	10
HSSI00332	3/32	57	10
HSSI00764	7/64	61	10
HSSI00108	1/8	65	10
HSSI00964	9/64	70	10
HSSI00532	5/32	75	10
HSSI001164	11/64	80	10
HSSI00316	3/16	80	10
HSSI001364	13/64	86	10

Part Number	Diameter inches	Overall Length mm	Pack Quantity
HSSI00732	7/32	93	10
HSSI00104	1/4	101	10
HSSI001764	17/64	109	10
HSSI00932	9/32	109	10
HSSI00516	5/16	117	10
HSSI001132	11/32	125	10
HSSI00308	3/8	133	10
HSSI001332	13/32	133	5
HSSI00716	7/16	142	5
HSSI00102	1/2	151	5



HSS • High Speed Steel Drill Bits • Metric in Wallets



Part Number	Diameter mm	Overall Length mm	Pack Quantity
HSSW010	1.0	34	3
HSSW015	1.5	40	3
HSSW020	2.0	49	3
HSSW025	2.5	57	3
HSSW030	3.0	61	3
HSSW035	3.5	70	2
HSSW040	4.0	75	2
HSSW045	4.5	80	2
HSSW050	5.0	86	2
HSSW055	5.5	93	2
HSSW060	6.0	93	2
HSSW065	6.5	101	1

Part Number	Diameter mm	Overall Length mm	Pack Quantity
HSSW070	7.0	109	1
HSSW075	7.5	109	1
HSSW080	8.0	117	1
HSSW085	8.5	117	1
HSSW090	9.0	125	1
HSSW095	9.5	125	1
HSSW100	10.0	133	1
HSSW105	10.5	133	1
HSSW110	11.0	142	1
HSSW115	11.5	142	1
HSSW120	12.0	151	1
HSSW125	12.5	151	1
HSSW130	13.0	151	1



Multidrill Tungsten Carbide Universal Drill • Metric



Part Number	Diameter mm	Overall Length mm	Pack Quantity
MUL040075	4	75	1
MUL050085	5	85	1
MUL050150	5	150	1
MUL055085	5.5	85	1
MUL055150	5.5	150	1
MUL060100	6	100	1
MUL060200	6	200	1
MUL065100	6.5	100	1
MUL065200	6.5	200	1
MUL070100	7	100	1
MUL070200	7	200	1
MUL080120	8	120	1
MUL080200	8	200	1
MUL100120	10	120	1
MUL100200	10	200	1
MUL120220	12	220	1
MUL140220	14	220	1
MULSET	4,5,6,8,10	-	1

HSS Cobalt High Speed Steel Drill • Metric



Part Number	Diameter mm	Overall Length mm	Pack Quantity
COB020	2.0	49	10
COB025	2.5	57	10
COB030	3.0	61	10
COB033	3.3	65	10
COB035	3.5	70	10
COB040	4.0	75	10
COB042	4.2	75	10
COB045	4.5	80	10
COB050	5.0	86	10
COB055	5.5	93	10
COB060	6.0	93	10
COB065	6.5	101	10
COB068	6.8	109	10
COB070	7.0	109	10
COB075	7.5	109	10
COB080	8.0	117	10
COB085	8.5	117	10
COB090	9.0	125	10
COB095	9.5	125	10
COB100	10.0	133	5
COB105	10.5	133	5
COB110	11.0	142	5
COB115	11.5	142	5
COB120	12.0	151	5
COB125	12.5	151	5
COB130	13.0	151	1



Polybag & Minibag Range

Shield Anchor • Projecting Bolt



Polybag Range		
Part Number	Quantity in Bag	Quantity of Bags Per Outer
APBBAG0610	10	5
APBBAG0625	10	5
APBBAG0650	10	5
APBBAG0815	10	5
APBBAG0840	10	5
APBBAG0880	10	5
APBBAG1030	10	5
APBBAG1070	10	5
APBBAG1215	5	5
APBBAG1250	5	5

Minibag Range		
Part Number	Quantity in Bag	Quantity of Bags Per Outer
AB105	2	10
AB106	2	10
AB107	2	10
AB108	2	10
AB110	2	10
AB111	2	10
AB115	2	10
AB116	2	10
AB117	2	10
AB118	2	10

Thread Diameter mm	Drill Diameter mm	Max. Fixture Thickness mm
6	12	10
6	12	25
6	12	50
8	14	15
8	14	40
8	14	80
10	16	30
10	16	70
12	20	15
12	20	50

Shield Anchor • Loose Bolt



Polybag Range		
Part Number	Quantity in Bag	Quantity of Bags Per Outer
ALBBAG0610	10	5
ALBBAG0625	10	5
ALBBAG0640	10	5
ALBBAG0810	10	5
ALBBAG0825	10	5
ALBBAG0840	10	5
ALBBAG1010	10	5
ALBBAG1025	10	5
ALBBAG1050	10	5
ALBBAG1075	10	5
ALBBAG1210	5	5
ALBBAG1225	5	5
ALBBAG1240	5	5
ALBBAG1260	5	5

Minibag Range		
Part Number	Quantity in Bag	Quantity of Bags Per Outer
AB135	2	10
AB136	2	10
AB137	2	10
AB140	2	10
AB141	2	10
AB142	2	10
AB143	2	10
AB145	2	10
AB146	2	10
AB147	2	10
AB148	2	10
AB149	2	10
AB150	2	10
AB151	2	10

Thread Diameter mm	Drill Diameter mm	Max. Fixture Thickness mm
6	12	10
6	12	25
6	12	40
8	14	10
8	14	25
8	14	40
10	16	10
10	16	25
10	16	50
10	16	75
12	20	10
12	20	25
12	20	40
12	20	60

Shield Anchor • Eye Bolt



Polybag Range		
Part Number	Quantity in Bag	Quantity of Bags Per Outer
AEBBAGM08	10	5

Minibag Range		
Part Number	Quantity in Bag	Quantity of Bags Per Outer
AB165	2	10

Thread Diameter mm	Drill Diameter mm	Max. Fixture Thickness mm
8	14	N/A

Shield Anchor • Hook Bolt



Polybag Range		
Part Number	Quantity in Bag	Quantity of Bags Per Outer
AHBBAGM08	10	5

Minibag Range		
Part Number	Quantity in Bag	Quantity of Bags Per Outer
AB170	2	10

Thread Diameter mm	Drill Diameter mm	Max. Fixture Thickness mm
8	14	N/A

For additional technical information see main product page

Polybag & Minibag Range

Metal Plasterboard Fixing with Screw



Polybag Range

Part Number	Quantity in Bag	Quantity of Bags Per Outer
JJPBAG15	20	5

Minibag Range

Part Number	Quantity in Bag	Quantity of Bags Per Outer
AB315	6	10

Thread Diameter mm	Screw Length mm	Max. Fixture Thickness mm
4.5	25	15

Nylon Plasterboard Fixing with Screw



Polybag Range

Part Number	Quantity in Bag	Quantity of Bags Per Outer
JJPNBAG10	20	5

Minibag Range

Part Number	Quantity in Bag	Quantity of Bags Per Outer
AB320	6	10

Thread Diameter mm	Screw Length mm	Max. Fixture Thickness mm
4.5	30	10

Rosett Cavity Fixing • Torx 25 Drive



Polybag Range

Part Number	Quantity in Bag	Quantity of Bags Per Outer	
BRBAG05055	6	10	Blue Rosett 5mm x 55mm
BRBAG05080	6	10	Blue Rosett 5mm x 80mm
BRBAGHOOK	4	10	Blue Rosett Hook

Polybag Range

Part Number	Quantity in Bag	Quantity of Bags Per Outer	
RRBAG05065	6	10	Red Rosett 5mm x 65mm
RRBAG05090	6	10	Red Rosett 5mm x 90mm
RRBAGHOOK	4	10	Red Rosett Hook

Plastic Toggle



Polybag Range

Part Number	Quantity in Bag	Quantity of Bags Per Outer
NTBAG10	50	5
NTBAG12	50	5
NTBAG16	50	5

Minibag Range

Part Number	Quantity in Bag	Quantity of Bags Per Outer
AB505	6	10
AB510	6	10
AB515	6	10

Thread Diameter mm	Screw Length mm	Max. Fixture Thickness mm
8	4.5	4-12
8	4.5	15-19
8	4.5	24-28

Hollow Wall Anchors



Polybag Range

Part Number	Quantity in Bag	Quantity of Bags Per Outer
LHWABAG04045	10	5
LHWABAG04050	10	5
LHWABAG05045	10	5

Minibag Range

Part Number	Quantity in Bag	Quantity of Bags Per Outer
AB330	4	10
AB335	4	10
AB340	4	10

Thread Diameter mm	Screw Length mm	Max. Fixture Thickness mm
8	4 x 45	8-13
8	4 x 50	16-20
10	5 x 45	5-10



Spring Toggles with Screw

Polybag Range

Part Number	Quantity in Bag	Quantity of Bags Per Outer
LSTBAG05050	10	5
LSTBAG05075	10	5
LSTBAG06075	10	5

Minibag Range

Part Number	Quantity in Bag	Quantity of Bags Per Outer
AB360	4	10
AB365	4	10
AB366	4	10

Thread Diameter mm	Screw Length mm	Max. Fixture Thickness mm
14	5 x 50	20
14	5 x 75	45
18	6 x 75	45



Masonry Nails

Minibag Range

Part Number	Quantity in Bag	Quantity of Bags Per Outer
BR725	30	10
BR730	25	10
BR740	20	10
BR750	14	10
BR760	12	10
BR775	7	10
BR7100	5	10

Shank Diameter mm	Shank Length mm
2.50	25
2.50	30
2.50	40
3.00	50
3.00	60
3.50	75
3.50	100

For additional technical information see main product page



Nylon Frame Fixings

Polybag Range

Part Number	Quantity in Bag	Quantity of Bags Per Outer
NFFBAG08060	20	5
NFFBAG08080	20	5
NFFBAG08100	20	5
NFFBAG08120	20	5
NFFBAG10100	20	5
NFFBAG10115	20	5
NFFBAG10135	20	5
NFFBAG10160	10	5

Minibag Range

Part Number	Quantity in Bag	Quantity of Bags Per Outer
AB400	4	10
AB405	4	10
AB406	4	10
AB407	4	10
AB410	4	10
AB411	4	10
AB415	4	10
AB416	4	10

Plug Length mm	Drill Diameter mm	Max. Fixture Thickness mm
60	8	20
80	8	40
100	8	60
120	8	80
100	10	55
120	10	70
140	10	90
160	10	115



Nylon Hammerscrews

Polybag Range

Part Number	Quantity in Bag	Quantity of Bags Per Outer
NHSBAG05050	50	5
NHSBAG06040	50	5
NHSBAG06050	50	5
NHSBAG06070	50	5
NHSBAG08080	20	5
NHSBAG08100	20	5
NHSBAG08120	20	5

Minibag Range

Part Number	Quantity in Bag	Quantity of Bags Per Outer
AB435	8	10
AB436	10	10
AB440	10	10
AB445	10	10
AB446	10	10
AB450	8	10
AB451	8	10

Plug Length mm	Drill Diameter mm	Max. Fixture Thickness mm
50	5	25
40	6	10
50	6	20
70	6	40
80	8	40
100	8	60
120	8	80

Polybag & Minibag Range

Coach Screw and Screw Sets



Polybag Range

Part Number	Quantity in Bag	Quantity of Bags Per Outer
CSPBAG06060	10	5
CSPBAG06080	10	5
CSPBAG08100	10	5
CSPBAG08120	10	5

Minibag Range

Part Number	Quantity in Bag	Quantity of Bags Per Outer
AB475	2	10
AB480	2	10
AB485	2	10
AB490	2	10

Plug Length mm	Drill Diameter mm	Max. Fixture Thickness mm
40	8	20
40	8	40
50	10	50
50	10	70

Concrete Screws



Polybag Range

Part Number	Quantity in Bag	Quantity of Bags Per Outer
CSBAG75060	20	5
CSBAG75080	20	5
CSBAG75100	20	5
CSBAG75120	20	5
CSBAG75150	10	5

Minibag Range

Part Number	Quantity in Bag	Quantity of Bags Per Outer
AB491	4	10
AB492	4	10
AB493	4	10
AB494	4	10
AB495	4	10

Plug Length mm	Drill Diameter mm	Max. Fixture Thickness mm
60	6	20
80	6	40
100	6	60
120	6	80
150	6	110

Universal Plug



Polybag Range

Part Number	Quantity in Bag	Quantity of Bags Per Outer
NUPBAG06035	50	5
NUPBAG08050	50	5

Minibag Range

Part Number	Quantity in Bag	Quantity of Bags Per Outer
AB305	10	10
AB310	10	10

Plug Length mm	Drill Diameter mm	Screw Diameter No
40	6	6-8
50	8	10-12

Nylon Plug



Polybag Range

Part Number	Quantity in Bag	Quantity of Bags Per Outer
NPBAG06	50	5
NPBAG07	50	5
NPBAG08	50	5

Minibag Range

Part Number	Quantity in Bag	Quantity of Bags Per Outer
AB530	20	10
AB535	20	10
AB540	20	10

Plug Length mm	Drill Diameter mm	Screw Diameter No
30	6	6-8
35	7	8-12
40	8	10-12

Plasterboard Plug



Polybag Range

Part Number	Quantity in Bag	Quantity of Bags Per Outer
PPBAG07	25	5

Minibag Range

Part Number	Quantity in Bag	Quantity of Bags Per Outer
AB545	10	10

Plug Length mm	Drill Diameter mm	Screw Diameter No
-	7	8



Sleeve Anchors • Hexagon Nut

Polybag Range

Part Number	Quantity in Bag	Quantity of Bags Per Outer
SLNBAG08065	10	5
SLNBAG08085	10	5
SLNBAG10050	10	5
SLNBAG10075	10	5
SLNBAG10100	10	5
SLNBAG12075	10	5
SLNBAG12100	10	5
SLNBAG16110	5	5

Minibag Range

Part Number	Quantity in Bag	Quantity of Bags Per Outer
AB200	2	10
AB205	2	10
AB206	2	10
AB210	2	10
AB211	2	10
AB215	2	10
AB216	2	10
AB217	2	10

Thread Diameter mm	Drill Diameter mm	Max. Fixture Thickness mm
6	8	30
6	8	50
8	10	8
8	10	35
8	10	62
10	12	22
10	12	45
12	16	49



Sleeve Anchors • Eye Bolt

AB235	2	10	6	8	N/A
-------	---	----	---	---	-----



Sleeve Anchors • Hookbolt

AB240	2	10	6	8	N/A
-------	---	----	---	---	-----



Throughbolt

Polybag Range

Part Number	Quantity in Bag	Quantity of Bags Per Outer
TBBAG08065	10	5
TBBAG08100	10	5
TBBAG10075	10	5
TBBAG10090	10	5
TBBAG10120	10	5
TBBAG12100	5	5
TBBAG16125	5	5

Minibag Range

Part Number	Quantity in Bag	Quantity of Bags Per Outer
AB250	2	10
AB251	2	10
AB252	2	10
AB253	2	10
AB254	2	10
AB255	2	10
AB256	2	10

Thread Diameter mm	Drill Diameter mm	Max. Fixture Thickness mm
8	8	20
8	8	55
10	10	18
10	10	33
10	10	63
12	12	25
16	16	30

Polybag & Minibag Range

Ankerbolts



Polybag Range			Minibag Range			Anchor Diameter mm	Drill Diameter mm	Max. Fixture Thickness mm
Part Number	Quantity in Bag	Quantity of Bags Per Outer	Part Number	Quantity in Bag	Quantity of Bags Per Outer			
JABBAG06050	10	5	AB600	2	10	6	5	20
JABBAG08050	10	5	AB601	2	10	8	6	20
JABBAG08075	10	5	AB602	2	10	8	6	45
JABBAG08100	10	5	AB603	2	10	8	6	55
JABBAG10060	10	5	AB604	2	10	10	8	20
JABBAG10075	10	5	AB605	2	10	10	8	35
JABBAG10100	10	5	AB606	2	10	10	8	60
JABBAG12075	10	5	AB607	2	10	12	10	25
JABBAG12100	10	5	AB608	2	10	12	10	50
JABBAG12150	10	5	AB609	2	10	12	10	100
JABBAG08050CS	10	5	AB610	2	10	8	6	20
JABBAG08075CS	10	5	AB611	2	10	8	6	45
JABBAG08100CS	10	5	AB612	2	10	8	6	55
JABBAG08050H	10	5	AB613	2	10	8	6	-
JABBAG08050E	10	5	AB614	2	10	8	6	-



Woodfix Light Section

Polybag Range			Screw Length mm	Max Fixture Thickness mm
Part Number	Quantity in Bag	Quantity of Bags Per Outer		
WFLBAG55040	50	5	40	22
WFLBAG55050	50	5	50	32
WFLBAG55060	50	5	60	42
WFLBAG55080	50	5	80	62
WFLBAG55100	50	5	100	82
WFLBAG55110	50	5	110	92



Woodfix Heavy Section

WFHBAG55050	50	5	50	23
WFHBAG55060	50	5	60	33
WFHBAG55070	50	5	70	43
WFHBAG55085	50	5	85	58
WFHBAG55109	50	5	109	82



Metalfix Light Section-No Washer

MFLBAG55025	50	5	25	10
MFLBAG55032	50	5	32	17
MFLBAG55038	50	5	38	23
MFLBAG55050	50	5	50	36



Metalfix Light Section - 19mm Washer

Polybag Range

MFLBAG55025W19	50	5	25	7
MFLBAG55032W19	50	5	32	14
MFLBAG55038W19	50	5	38	20
MFLBAG55050W19	50	5	50	32



Metalfix Heavy Section - 19mm Washer

MFHBAG55022W19	50	5	22	1.2
MFHBAG55032W19	50	5	32	2
MFHBAG55040W19	50	5	40	10
MFHBAG55050W19	50	5	50	20



Gashpoint Screw - 19mm Washer

GPBAG63032W19	50	5	32	1.4
GPBAG63045W19	50	5	45	1.4



Stitching Screw - 19mm Washer

SSBAG63025W19	50	5	25	2 x 0.9
---------------	----	---	----	---------

Polybag & Minibag Range

Loose EDPM Washer



MFWBAG16	100	5	-	-
MFWBAG19	100	5	-	-



Wafer Head Screw

WHBAG4213	200	5	13	1
-----------	-----	---	----	---



5/16" Drive Socket

MFBAG516	1	5	-	-
----------	---	---	---	---



Merlin Grey - 19mm Cover Cap

MFCBAG19MG	100	5	-	-
------------	-----	---	---	---

DUCK FOOT

Duckfoot

Product Codes Begin DUCKFOOT Product Group 37



The Duck Foot anchor is a new patented drywall fixing that easily and quickly provides a strong and secure mounting in both single and double drywall. Ideal areas of application are modular shelf rails, brackets, wall units, TV mounts, lamps, etc.

No pre-drilling is required and the integrated drill ensures that the hole is the right dimension, which is no bigger than 12mm. The supplied screw is 5mm and permits an object thickness up to 22mm. Installation is carried out using a power drill and a PH2 standard bit.

Article Number	Description	Box Qty
OJ574929	M5 x 70mm Pack of 25	1
OJ574912	M5 x 70mm Pack of 8	1

Benefits of using Duck Foot:

- **Reliable**
- **Easy-to-use**
- **Reduced hole size**
- **Strong Anchor**
- **Multiple Applications**



Watch the video on

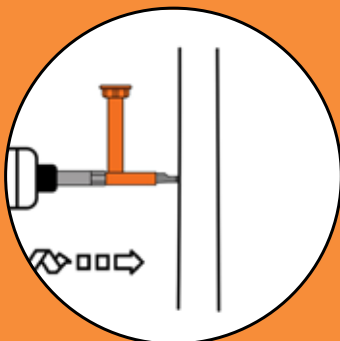

1. Drill

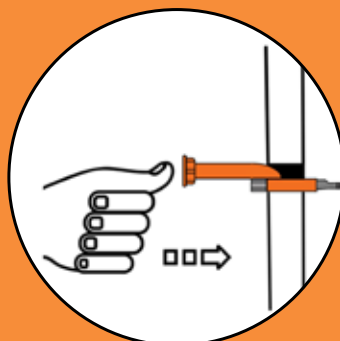

2. Push

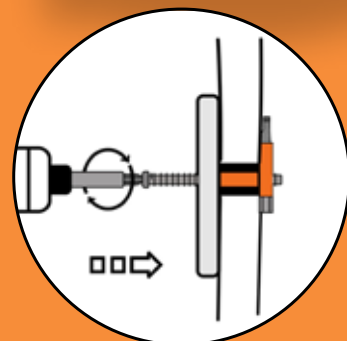

3. Attach

UNIFIX[®]

Trade • Retail



Trade Bag: The Unifix branded trade bag range covers popular products and sizes from a wide selection of fasteners and fixings.

The packaging is robust, re-sealable, drop-proof, water resistant, easy to identify, and an ideal size to carry.

Retail: The Unifix branded retail range follows a similar offering to the trade bag range, conveniently packed in small pack quantities.





DESIGNED TO PROMOTE BRAND LOYALTY WITH YOUR CUSTOMERS.





Trade Bag Range

Woodscrews

Twinthread Woodscrews BZP

Trade Bag

Product Codes Begin **POU9TQCSKPZ** Product Group **150**



Article No.	Size	Bag Qty.			
OJ540795	6 x 5/8	700	OJ540870	8 x 2.1/2	200
OJ540801	6 x 3/4	620	OJ540887	8 x 3	175
OJ540818	6 x 1	500	OJ540894	10 x 1.1/2	225
OJ540825	8 x 3/4	540	OJ540900	10 x 2	190
OJ540832	8 x 1	470	OJ540917	10 x 2.1/2	150
OJ540849	8 x 1.1/4	390	OJ540924	10 x 3	120
OJ540856	8 x 1.1/2	350	OJ540931	10 x 4	90
OJ540863	8 x 2	270			



General Purpose Woodscrews BZP DIN 571

Trade Bag

Product Codes Begin **POU9CHIPPY** Product Group **150**

OJ540948	3.5 x 30	500	OJ541013	5.0 x 40	220	OJ541082	6.0 x 120	50
OJ540955	4.0 x 25	500	OJ541020	5.0 x 50	180	OJ541099	6.0 x 150	35
OJ540962	4.0 x 30	430	OJ541037	5.0 x 60	160			
OJ540979	4.0 x 35	380	OJ541044	5.0 x 70	140			
OJ540986	4.0 x 40	350	OJ541051	5.0 x 80	120			
OJ540993	4.0 x 50	280	OJ541068	5.0 x 100	90			
OJ541006	4.0 x 60	230	OJ541075	6.0 x 80	75			



Drywall Screws - Sharp Point Black

Trade Bag

Product Codes Begin **POU9TQDBLBUG** Product Group **150**

OJ541105	3.5 x 32	400	OJ541136	3.5 x 50	250
OJ541112	3.5 x 38	350	OJ541143	3.5 x 60	200
OJ541129	3.5 x 42	320	OJ541150	4.2 x 75	130



Drywall Screws-Self Drill ZYP

Trade Bag

Product Codes Begin **POU9TQDSDBG** Product Group **150**

OJ541167	3.5 x 32	400
OJ541174	3.5 x 42	320



Woodscrew Accessories



Domecap Screw Covers

Trade Bag

Product Codes Begin **POU9TQDOMETOP** Product Group **150**

Article No.	Size	Bag Qty.
OJ046440	White	400

Heavy Duty Woodscrews



Hex Head Coach Screws BZP DIN 571

Trade Bag

Product Codes Begin **POU^HXC** Product Group **150**

OJ540429	M6 x 50	120	OJ540481	M8 x 100	40	OJ540542	M10 x 150	16
OJ540436	M6 x 70	100	OJ540498	M10 x 50	40	OJ540559	M12 x 80	20
OJ540443	M6 x 100	70	OJ540504	M10 x 80	28	OJ540566	M12 x 100	16
OJ540450	M8 x 50	70	OJ540511	M10 x 100	24	OJ540573	M12 x 150	12
OJ540467	M8 x 60	60	OJ540528	M10 x 120	20			
OJ540474	M8 x 80	48	OJ540535	M10 x 130	18			



Timberdrive Screws Green

Trade Bag

Product Codes Begin **POUTDSBX** Product Group **150**

OJ541181	M7 x 100	400
OJ541198	M7 x 150	350



Decking Screws Green

Trade Bag

Product Codes Begin **POU9DECSREW** Product Group **150**

OJ541211	8 x 2	150
OJ541228	8 x 2.1/2	125
OJ541235	8 x 3	100
OJ541242	10 x 3	75

Bolts



Roofing Bolts & Nuts BZP

Trade Bag

Product Codes Begin **POU^AHXC** Product Group **150**

Article No.	Size	Bag Qty.			
OJ540344	M6 x 12	150	OJ540382	M6 x 40	110
OJ540351	M6 x 20	140	OJ540399	M6 x 50	90
OJ540368	M6 x 25	130	OJ540405	M6 x 60	80
OJ540375	M6 x 30	120	OJ540412	M6 x 80	70



High Tensile Set Screws & Nuts BZP

Trade Bag

Product Codes Begin **POUMHSN** Product Group **150**

OJ540016	M6 x 16	130	OJ540092	M8 x 70	30	OJ540177	M12 x 30	23
OJ540023	M6 x 20	115	OJ540108	M10 x 25	35	OJ540184	M12 x 35	22
OJ540030	M6 x 25	100	OJ540115	M10 x 30	32	OJ540191	M12 x 40	20
OJ540047	M6 x 50	70	OJ540122	M10 x 40	28	OJ540207	M12 x 50	18
OJ540054	M8 x 20	60	OJ540139	M10 x 50	25	OJ540214	M12 x 70	14
OJ540061	M8 x 25	55	OJ540146	M10 x 70	20	OJ540221	M12 x 100	10
OJ540078	M8 x 40	45	OJ540153	M10 x 100	16			
OJ540085	M8 x 50	40	OJ540160	M12 x 25	25			



Cup Square Hex Bolts & Nuts BZP

Trade Bag

Product Codes Begin **POU CSXD** Product Group **150**

OJ571096	M6 x 50	90	OJ540610	M8 x 150	25	OJ571164	M10 x 180	15
OJ571102	M6 x 100	55	OJ571140	M8 x 200	12	OJ571188	M10 x 200	15
OJ571119	M6 x 150	25	OJ571157	M10 x 50	45	OJ571195	M12 x 50	18
OJ571126	M8 x 50	55	OJ540627	M10 x 75	25	OJ540672	M12 x 100	14
OJ571133	M8 x 75	40	OJ540634	M10 x 100	20	OJ540689	M12 x 130	12
OJ540580	M8 x 100	35	OJ540641	M10 x 120	20	OJ540696	M12 x 150	10
OJ540597	M8 x 110	35	OJ540658	M10 x 130	18	OJ571201	M12 x 180	8
OJ540603	M8 x 130	30	OJ540665	M10 x 150	15	OJ571218	M12 x 200	5



Nuts

Hex Full Nuts BZP DIN 934



Trade Bag

Product Codes Begin **POUNFFMS** Product Group **150**

OJ540238	M6	600	OJ540269	M12	90
OJ540245	M8	300	OJ540276	M16	45
OJ540252	M10	130	OJ540283	M20	20

Nylon Insert Nuts Type P - BZP DIN 982



Trade Bag

Product Codes Begin **POUNIPMS** Product Group **150**

OJ540290	M6	300	OJ540320	M12	70
OJ540306	M8	200	OJ540337	M16	30
OJ540313	M10	100			

Washers

Form A Washers BZP DIN 125A



Trade Bag

Product Codes Begin **POUWSA DS** Product Group **150**

OJ540702	M6	500	OJ540733	M12	130
OJ540719	M8	350	OJ540740	M16	75
OJ540726	M10	200	OJ540757	M20	50

Mudguard Washers BZP



Trade Bag

Product Codes Begin **POUWSMMS** Product Group **150**

OJ540764	M6 x 25	160
OJ540771	M8 x 25	150
OJ540788	M12 x 38	75

Nails & Pins

Bright Annular Ringshank Nails



Trade Bag

Product Codes Begin **POU9ARSN** Product Group **150**

Article No.	Size	Bag Qty.			
OJ016894	20 x 2.00	500g	OJ016931	50 x 2.65	500g
OJ541884	20 x 2.00	1KG	OJ541921	50 x 2.65	1KG
OJ016900	25 x 2.00	500g	OJ016948	65 x 3.35	500g
OJ541891	25 x 2.00	1KG	OJ541938	65 x 3.35	1KG
OJ016917	30 x 2.36	500g	OJ016955	75 x 3.75	500g
OJ541907	30 x 2.36	1KG	OJ541945	75 x 3.75	1KG
OJ016924	40 x 2.65	500g			
OJ541914	40 x 2.65	1KG			

Bright Oval Brad Nails



Trade Bag

Product Codes Begin **POU9OBN** Product Group **150**

OJ016962	40mm	500g	OJ016993	75mm	500g
OJ541952	40mm	1KG	OJ541983	75mm	1KG
OJ016979	50mm	500g	OJ017006	100mm	500g
OJ541969	50mm	1KG	OJ541990	100mm	1KG
OJ016986	65mm	500g			
OJ541976	65mm	1KG			

Bright Panel Pins



Trade Bag

Product Codes Begin **POU9PP** Product Group **150**

OJ017013	25 x 1.60	500g	OJ017037	40 x 1.60	500g
OJ542003	25 x 1.60	1KG	OJ542027	40 x 1.60	1KG
OJ017020	30 x 1.60	500g	OJ017044	50 x 2.00	500g
OJ542010	30 x 1.60	1KG	OJ542034	50 x 2.00	1KG

Bright Round Lost Head Nails



Trade Bag

Product Codes Begin **POU9LHRWN** Product Group **150**

OJ017051	40 x 2.36	500g
OJ542041	40 x 2.36	1KG
OJ017068	50 x 3.00	500g
OJ542058	50 x 3.00	1KG
OJ017075	65 x 3.35	500g
OJ542065	65 x 3.35	1KG



Bright Round Wire Nails

Trade Bag

Product Codes Begin **POU9RWN** Product Group **150**

Article No.	Size	Bag Qty.						
OJ017082	40 x 2.65	500g	OJ542096	65 x 3.35	1KG	OJ017136	125 x 5.60	500g
OJ542072	40 x 2.65	1KG	OJ017112	75 x 3.75	500g	OJ542126	125 x 5.60	1KG
OJ017099	50 x 2.65	500g	OJ542102	75 x 3.75	1KG	OJ017143	150 x 6.00	500g
OJ542089	50 x 2.65	1KG	OJ017129	100 x 4.50	500g	OJ542133	150 x 6.00	1KG
OJ017105	65 x 3.35	500g	OJ542119	100 x 4.50	1KG			



Bright Cut Clasp Nails

Trade Bag

Product Codes Begin **POU9CN** Product Group **150**

OJ017471	50mm	500g	OJ017495	75mm	500g
OJ542461	50mm	1KG	OJ542485	75mm	1KG
OJ017488	65mm	500g	OJ017501	100mm	500g
OJ542478	65mm	1KG	OJ542492	100mm	1KG



Bright Cut Floor Brad Nails

Trade Bag

Product Codes Begin **POU9FB** Product Group **150**

OJ017518	50mm	500g	OJ017525	65mm	500g
OJ542508	50mm	1KG	OJ542515	65mm	1KG



Aluminium Clout Nails

Trade Bag

Product Codes Begin **POU9ALCN** Product Group **150**

OJ567518	30 x 2.65	1kg	OJ567549	50 x 3.35	1kg
OJ567525	38 x 2.65	1kg	OJ567556	65 x 3.35	1kg
OJ567532	38 x 3.35	1kg			



Copper Slate Nails

Trade Bag

Product Codes Begin **POU9RWCUSLAN** Product Group **150**

OJ567563	30 x 2.65	1kg	OJ567594	38 x 3.35	1kg
OJ567570	30 x 3.35	1kg	OJ567600	50 x 3.35	1kg
OJ567587	38 x 2.65	1kg			



Galvanised Clout Nails

Trade Bag

Product Codes Begin **POU9GALVCN** Product Group **150**

OJ017150	25 x 2.65	500g	OJ542171	40 x 3.35	1KG	OJ017228	65 x 3.75	500g
OJ542140	25 x 2.65	1KG	OJ017198	50 x 2.65	500g	OJ542218	65 x 3.75	1KG
OJ017167	30 x 2.65	500g	OJ542188	50 x 2.65	1KG	OJ017235	75 x 3.75	500g
OJ542157	30 x 2.65	1KG	OJ017204	50 x 3.35	500g	OJ542225	75 x 3.75	1KG
OJ017174	40 x 2.65	500g	OJ542195	50 x 3.35	1KG			
OJ542164	40 x 2.65	1KG	OJ017211	65 x 2.65	500g			
OJ017181	40 x 3.35	500g	OJ542201	65 x 2.65	1KG			



Galvanised ELH Clout Nails

Trade Bag

Product Codes Begin **POU9GALVELHCN** Product Group **150**

OJ017242	13 x 3.00	500g	OJ017273	30 x 3.00	500g
OJ542232	13 x 3.00	1KG	OJ542263	30 x 3.00	1KG
OJ017259	20 x 3.00	500g	OJ017280	40 x 3.00	500g
OJ542249	20 x 3.00	1KG	OJ542270	40 x 3.00	1KG
OJ017266	25 x 3.00	500g	OJ017297	50 x 3.00	500g
OJ542256	25 x 3.00	1KG	OJ542287	50 x 3.00	1KG



Galvanised Round Wire Nails

Trade Bag

Product Codes Begin **POU9GALVRWN** Product Group **150**

OJ017303	40 x 2.65	500g	OJ542324	65 x 3.35	1KG	OJ017372	150 x 6.00	500g
OJ542294	40 x 2.65	1KG	OJ017341	75 x 3.75	500g	OJ542362	150 x 6.00	1KG
OJ017310	50 x 2.65	500g	OJ542331	75 x 3.75	1KG			
OJ542300	50 x 2.65	1KG	OJ017358	100 x 4.50	500g			
OJ017327	65 x 2.65	500g	OJ542348	100 x 4.50	1KG			
OJ542317	65 x 2.65	1KG	OJ017365	125 x 5.60	500g			
OJ017334	65 x 3.35	500g	OJ542355	125 x 5.60	1KG			



Galvanised Spring Head Roofing Nails

Trade Bag

Product Codes Begin **POUSPRNTQ** Product Group **150**

Article No.	Size	Bag Qty.
OJ567617	65 x 3.35	1kg



Galvanised Square Twist Nails

Trade Bag

Product Codes Begin **POUGALVSQTN** Product Group **150**

OJ017389	30 x 3.75	500g
OJ542379	30 x 3.75	1KG
OJ017396	40 x 3.75	500g
OJ542386	40 x 3.75	1KG



Galvanised Staples

Trade Bag

Product Codes Begin **POU9GALVSTAP** Product Group **150**

OJ017402	20 x 2.00	500g	OJ542416	30 x 3.55	1KG
OJ542393	20 x 2.00	1KG	OJ017433	40 x 4.00	500g
OJ017419	25 x 2.65	500g	OJ542423	40 x 4.00	1KG
OJ542409	25 x 2.65	1KG	OJ017440	50 x 5.00	500g
OJ017426	30 x 3.55	500g	OJ542430	50 x 5.00	1KG



Galvanised Jagged Edge Plasterboard Nails

Trade Bag

Product Codes Begin **POU9GALVNP** Product Group **150**

OJ017457	30 x 2.65	500g	OJ017464	40 x 2.65	500g
OJ542447	30 x 2.65	1KG	OJ542454	40 x 2.65	1KG



Galvanised Drive Screw Nails

Trade Bag

Product Codes Begin **POU9GALVCHDS** Product Group **150**

OJ017532	65 x 5.40	500g	OJ017563	125 x 6.40	500g
OJ542522	65 x 5.40	1KG	OJ542553	125 x 6.40	1KG
OJ017549	75 x 5.40	500g	OJ017570	150 x 6.40	500g
OJ542539	75 x 5.40	1KG	OJ542560	150 x 6.40	1KG
OJ017556	100 x 5.40	500g			
OJ542546	100 x 5.40	1KG			



Sheradised Panel Pins

Trade Bag

Product Codes Begin **POU9SHERPP** Product Group **150**

Article No.	Size	Bag Qty.			
OJ017587	25 x 1.60	500g	OJ542584	30 x 1.60	1KG
OJ542577	25 x 1.60	1KG	OJ017600	40 x 1.60	500g
OJ017594	30 x 1.60	500g	OJ542591	40 x 1.60	1KG



Sheradised Annular Ring Shank Nails

Trade Bag

Product Codes Begin **POU9SHERARSN** Product Group **150**

OJ017617	40 x 2.65	500g	OJ542621	65 x 3.35	1KG
OJ542607	40 x 2.65	1KG	OJ017648	75 x 3.75	500g
OJ017624	50 x 2.65	500g	OJ542638	75 x 3.75	1KG
OJ542614	50 x 2.65	1KG	OJ017655	100 x 5.00	500g
OJ017631	65 x 3.35	500g	OJ542645	100 x 5.00	1KG



Sheradised Square Twist Nails

Trade Bag

Product Codes Begin **POU9SHERSQTN** Product Group **150**

OJ017662	30 x 3.75	500g
OJ542652	30 x 3.75	1KG

General Accessories



Worktop Jointing Bolt

Trade Bag

Product Codes Begin **POUZWTCCLAMP** Product Group **150**

OJ046464	150mm	160
----------	-------	-----



Modesty Block

Trade Bag

Product Codes Begin **POU9HBLOCK** Product Group **150**

OJ46457		0
---------	--	---



Metal Anchors



Through Bolts BZP

Trade Bag

Product Codes Begin **POUFJAWA** Product Group **150**

Article No.	Size	Bag Qty.			
OJ541259	M8 x 50	40	OJ541280	M12 x 140	10
OJ541266	M10 x 100	18	OJ541297	M12 x 180	8
OJ541273	M12 x 100	12			



Loose Bolt Shield Anchors ZYP

Trade Bag

Product Codes Begin **POUFJALB** Product Group **150**

OJ541303	M6 x 10	48	OJ541341	M8 x 40	22	OJ541389	M10 x 75	14
OJ541310	M6 x 25	46	OJ541358	M10 x 10	22	OJ541396	M12 x 60	10
OJ541327	M8 x 10	26	OJ541365	M10 x 25	16			
OJ541334	M8 x 25	26	OJ541372	M10 x 50	14			



ZYP Projecting Bolt Shield Anchors

Pouch Bag

Product Codes Begin **POUFJAPB** Product Group **150**

OJ541402	M10 x 30	15
----------	----------	----



Concrete Bolts ZP

Pouch Bag

Product Codes Begin **POUFJJAB** Product Group **150**

OJ541617	5mm x 50	Flange	64	OJ541679	8mm x 100	Hex Head	12
OJ541624	6mm x 50	Flange	30	OJ541686	8mm x 150	Hex Head	8
OJ541631	6mm x 75	Flange	26	OJ541693	10mm x 75	Hex Head	12
OJ541648	6mm x 100	Flange	20	OJ541709	10mm x 100	Hex Head	8
OJ541655	8mm x 60	Hex Head	18	OJ541716	10mm x 130	Hex Head	6
OJ541662	8mm x 75	Hex Head	14	OJ541723	10mm x 150	Hex Head	6



Light Duty Fixings

Concrete Screws ZYP



Trade Bag

Product Codes Begin **POUFJCS** Product Group **150**

Article No.	Size	Bag Qty.
OJ541570	M7.5 x 80	65
OJ541587	M7.5 x 100	55
OJ541594	M7.5 x 120	45
OJ541600	M7.5 x 150	30



Nylon Frame Fixings

Nylon Frame Fixings

Trade Bag

Product Codes Begin **POUFJNF** Product Group **150**

OJ541419	M8 x 80	50	OJ541440	M10 x 120	25
OJ541426	M8 x 100	40	OJ541457	M10 x 140	20
OJ541433	M10 x 100	30	OJ541464	M10 x 160	15



Nylon Hammerscrews

Trade Bag

Product Codes Begin **POUFJNHS** Product Group **150**

OJ541471	M6 x 40	135
OJ541488	M6 x 60	100
OJ541495	M6 x 80	80
OJ541501	M8 x 100	40

Plugs

Nylon Wall Plugs



Trade Bag

Product Codes Begin **POUFJN** Product Group **150**

OJ541518	M6	200
OJ541525	M8	100
OJ541532	M10	70



Cavity Fixings



Blue Rosett Cavity Fixings

Trade Bag

Product Codes Begin **POUFJBR** Product Group **150**

Article No.	Size	Bag Qty.
OJ541563		10



Plasterboard Fixings Metal

Trade Bag

Product Codes Begin **POUFJJJP** Product Group **150**

OJ541549		75
----------	--	----



Hollow Wall Anchors ZYP

Trade Bag

Product Codes Begin **POUFJLHWA** Product Group **150**

OJ541556	M6 x 60	40
----------	---------	----

Self Drilling Screws



Light Self Drilling Screws c/w 16mm Washer

Trade Bag

Product Codes Begin **POUFJMFL** Product Group **150**

OJ541792	M5.5 x 25	140
OJ541808	M5.5 x 38	110
OJ541815	M5.5 x 50	85



Heavy Self Drilling Screws c/w 16mm Washer

Trade Bag

Product Codes Begin **POUFJMFH** Product Group **150**

OJ541822	M5.5 x 40	100
----------	-----------	-----



Self Drill Screws

Trade Bag

Product Codes Begin **POUFJMFL** Product Group **150**

Article No.	Size	Bag Qty.			
OJ541754	M5.5 x 25	200	OJ541778	M5.5 x 38	26
OJ541761	M5.5 x 32	30	OJ541785	M5.5 x 50	20



Self Drill Screws Countersunk ZP

Trade Bag

Product Codes Begin **POUFJWFL** Product Group **150**

OJ541846	M5.5 x 40	100	OJ541860	M5.5 x 60	100
OJ541853	M5.5 x 50	100	OJ541877	M5.5 x 80	100



Stitching Screws with 16mm Washer

Trade Bag

Product Codes Begin **POUFJSS** Product Group **150**

OJ541839	M6.3 x 25	120
----------	-----------	-----



ZP Gash Point Screws

Trade Bag

Product Codes Begin **POUFJGP** Product Group **150**

OJ541730	M6.3 x 32	65
OJ541747	M6.3 x 45	55



Retail Bag Range

Woodscrews

Vortex™ Power Screws - ZYP

Retail Bag

Product Codes Begin **UBZZV** Product Group **151**



Article No.	Size	Bag Qty.			
UB1312	4 x 40	25	UB1336	5 x 100	25
UB1315	4 x 50	25	UB1351	6 x 100	25
UB1327	5 x 50	25	UB1354	6 x 150	15
UB1330	5 x 70	25	UB1357	6 x 180	15
UB1333	5 x 80	25	UB1360	6 x 200	15



Twinthread Woodscrews - BZP

Retail Bag

Product Codes Begin **UB9TQCSKPZ** Product Group **151**

UB1003	4 x 1/2	50	UB1039	8 x 3/4	50	UB1072	10 x 2	25
UB1009	4 x 3/4	50	UB1042	8 x 1	50	UB1075	10 x 2.1/2	25
UB1012	6 x 1/2	50	UB1045	8 x 1.1/4	25	UB1078	10 x 3	25
UB1015	6 x 5/8	50	UB1048	8 x 1.1/2	25	UB1081	10 x 3.1/2	15
UB1018	6 x 3/4	50	UB1051	8 x 1.3/4	25	UB1084	10 x 4	15
UB1021	6 x 1	50	UB1054	8 x 2	25	UB1087	12 x 1.1/2	25
UB1024	6 x 1.1/4	25	UB1057	8 x 2.1/2	25	UB1090	12 x 2	25
UB1027	6 x 1.1/2	25	UB1060	10 x 1	50	UB1093	12 x 2.1/2	25
UB1030	6 x 2	25	UB1063	10 x 1.1/4	25	UB1096	12 x 3	25
UB1033	7 x 1	50	UB1066	10 x 1.1/2	25	UB1099	12 x 4	15
UB1036	7 x 1.1/4	25	UB1069	10 x 1.3/4	25			



General Purpose Woodscrews - ZYP

Retail Bag

Product Codes Begin **UB9CHIPPY** Product Group **151**

UB1102	3.0 x 12	50	UB1138	4.0 x 50	25	UB1174	5.0 x 100	15
UB1111	3.5 x 16	50	UB1141	4.0 x 60	25	UB1180	6.0 x 60	25
UB1114	3.5 x 20	50	UB1144	4.0 x 70	25	UB1183	6.0 x 70	25
UB1117	3.5 x 25	50	UB1159	5.0 x 40	25	UB1189	6.0 x 100	15
UB1120	3.5 x 30	25	UB1162	5.0 x 50	25	UB1192	6.0 x 130	8
UB1129	4.0 x 25	50	UB1165	5.0 x 60	25	UB1195	6.0 x 150	6
UB1132	4.0 x 30	25	UB1168	5.0 x 70	25	UB1198	6.0 x 180	6
UB1135	4.0 x 40	25	UB1171	5.0 x 80	25	UB1201	6.0 x 200	4



General Purpose Woodscrews - Stainless Steel

Retail Bag

Product Codes Begin **UB9STSTCHIPPY** Product Group **151**

Article No.	Size	Bag Qty.			
UB1204	4.0 x 30	25	UB1213	5.0 x 40	25
UB1207	4.0 x 40	25	UB1216	5.0 x 50	25
UB1210	4.0 x 50	25	UB1219	5.0 x 70	25



Brass Slotted Countersunk Woodscrews

Retail Bag

Product Codes Begin **UB9TQCSKBWS** Product Group **151**

UB1506	4 x 1/2	25	UB1527	8 x 1	25	UB1545	10 x 2.1/2	10
UB1509	4 x 3/4	25	UB1530	8 x 1.1/4	25	UB1548	12 x 2.1/2	6
UB1512	6 x 1/2	25	UB1533	8 x 1.1/2	20			
UB1515	6 x 3/4	25	UB1536	8 x 2	15			
UB1518	6 x 1	25	UB1539	10 x 1.1/2	15			
UB1524	8 x 3/4	25	UB1542	10 x 2	10			



Chrome Effect Slotted Raised Woodscrews

Retail Bag

Product Codes Begin **UB9TQRSDCWS** Product Group **151**

UB1569	6 x 3/4	25	UB1578	8 x 1.1/4	15
UB1572	6 x 1	25	UB1581	8 x 1.1/2	15
UB1575	8 x 1	20			



Black Japanned Slotted Round Woodscrews

Retail Bag

Product Codes Begin **UB9TQJRNDWS** Product Group **151**

UB1584	6 x 3/4	25	UB1605	10 x 1	25
UB1590	8 x 3/4	25	UB1608	10 x 1.1/4	25
UB1593	8 x 1	25	UB1611	10 x 1.1/2	25
UB1596	8 x 1.1/4	25	UB1614	10 x 2	25
UB1599	8 x 1.1/2	25			
UB1602	8 x 2	25			



Mirror Screws CP Dometop BZP Screw

Retail Bag

Product Codes Begin **UB9TQCPDTSWS** Product Group **151**

UB1617	8 x 1	4
UB1620	8 x 1.1/4	4
UB1623	8 x 1.1/2	4



Antivandal Screws - Clutch Head

Retail Bag

Product Codes Begin **UB9TQCLUTCH** Product Group **151**

Article No.	Size	Bag Qty.
UB1626	8 x 1.1/4	25
UB1629	10 x 1.1/2	25

Woodscrew Accessories

Domecap Screw Covers



Retail Bag

Product Codes Begin **UB9TQDOMETOP** Product Group **151**

UB2003	Chrome Plated	20
UB2006	White	20
UB2012	Black	20
UB2015	LT Brown	20
UB2018	White Hinged	100

Plustop Screw Covers



Retail Bag

Product Codes Begin **UB9TQPLUSTOP** Product Group **151**

UB2021	White	50
UB2024	Brown	50

Brass Surface Pattern Screw Cups



Retail Bag

Product Codes Begin **UB9TQBSURFSCU** Product Group **151**

UB2030	6G	50
UB2033	7-8G	50
UB2036	9-10G	50

Nickel Plated Surface Pattern Screw Cups



Retail Bag

Product Codes Begin **UB9TQNPBSURF** Product Group **151**

UB2039	6G	50
UB2042	7-8G	50
UB2045	9-10G	50

Hooks & Eyes



White Cup Hooks

Retail Bag

Product Codes Begin **UB9TQCUPHKW** Product Group **151**

Article No.	Size	Bag Qty.
UB2051	25mm	10
UB2054	32mm	8
UB2057	38mm	6



EB Cup Hooks

Retail Bag

Product Codes Begin **UB9TQCUPHKEB** Product Group **151**

UB2063	25mm	10
UB2066	32mm	8
UB2069	38mm	6



EB Square Cup Hooks

Retail Bag

Product Codes Begin **UB9TQSQHKEB** Product Group **151**

UB2075	25mm	10
UB2078	32mm	8



BZP M Hooks

Retail Bag

Product Codes Begin **UB9TQSMHK** Product Group **151**

UB2084	55mm	10	UB2090	80mm	4
UB2087	60mm	6	UB2093	100mm	2



BZP Screw Eyes

Retail Bag

Product Codes Begin **UB9TQSSEYE** Product Group **151**

UB2099	35mm	10	UB2108	65mm	5
UB2102	45mm	10	UB2111	75mm	3
UB2105	55mm	10			



Picture Hooks

Retail Bag

Product Codes Begin **UB9TQPICKK** Product Group **151**

Article No.	Size	Bag Qty.			
UB2503	3.5M Wire	1	UB2509	Large	6
UB2506	Small	6	UB2512	Double	3

Self Tapping Screws



BZP Recessed Pan Head

Retail Bag

Product Codes Begin **UB4203** Product Group **151**

UB1803	6 x 1/2	50	UB1818	8 x 1	50	UB1833	10 x 1	50
UB1806	6 x 3/4	50	UB1821	8 x 1.1/4	25	UB1836	10 x 1.1/2	25
UB1809	6 x 1	50	UB1824	8 x 1.1/2	25	UB1839	10 x 2	25
UB1812	8 x 1/2	50	UB1827	8 x 2	25			
UB1815	8 x 3/4	50	UB1830	10 x 3/4	50			



Self Tapping Screws - Countersunk Recessed

Retail Bag

Product Codes Begin **UB4200** Product Group **151**

UB1842	6 x 1/2	50	UB1860	10 x 3/4	50
UB1845	6 x 3/4	50	UB1863	10 x 1	50
UB1848	8 x 3/4	50	UB1866	10 x 1.1/4	25
UB1851	8 x 1	50	UB1869	10 x 1.1/2	25
UB1854	8 x 1.1/4	25			
UB1857	8 x 1.1/2	25			

Heavy Duty Woodscrews



BZP Coach Screws DIN 571

Retail Bag

Product Codes Begin **UB^HXC** Product Group **151**

UB3003	M6 x 40	10	UB3018	M8 x 75	5	UB3039	M10 x 100	5
UB3006	M6 x 50	10	UB3021	M8 x 90	5	UB3042	M10 x 130	5
UB3009	M6 x 65	10	UB3024	M8 x 100	5	UB3045	M10 x 150	5
UB3012	M6 x 75	10	UB3027	M8 x 120	5	UB3048	M12 x 75	5
UB3066	M8 x 50	25	UB3030	M8 x 150	5	UB3051	M12 x 100	4
UB3015	M8 x 50	5	UB3033	M10 x 50	5	UB3054	M12 x 150	4
UB3069	M8 x 75	25	UB3036	M10 x 75	5			



Heavy Duty Timber Screws ZYP

Retail Bag

Product Codes Begin **UBTTSF** Product Group **151**

Article No.	Size	Finish.	Bag Qty.				
UB3211	8 x 80	Csk	10	UB3235	8 x 80	Flange	10
UB3214	8 x 120	Csk	10	UB3238	8 x 120	Flange	10
UB3217	8 x 160	Csk	6	UB3241	8 x 160	Flange	6
UB3220	8 x 200	Csk	6	UB3244	8 x 200	Flange	6
UB3223	8 x 240	Csk	6	UB3247	8 x 240	Flange	6

Bolts



Cup Square Hex Bolts & Nuts BZP

Retail Bag

Product Codes Begin **UB CSXD** Product Group **151**

Article No.	Size	Bag Qty.						
UB3103	M6 x 25	10	UB3136	M8 x 75	10	UB3169	M10 x 150	5
UB3106	M6 x 40	10	UB3139	M8 x 90	5	UB3172	M10 x 180	5
UB3109	M6 x 50	10	UB3142	M8 x 100	5	UB3175	M10 x 200	5
UB3112	M6 x 65	10	UB3145	M8 x 130	5	UB3178	M12 x 75	4
UB3115	M6 x 75	10	UB3148	M8 x 150	5	UB3181	M12 x 100	4
UB3118	M6 x 90	5	UB3151	M10 x 65	5	UB3184	M12 x 130	4
UB3121	M6 x 100	5	UB3154	M10 x 75	5	UB3187	M12 x 150	4
UB3124	M6 x 130	5	UB3157	M10 x 90	5	UB3190	M12 x 180	4
UB3127	M8 x 40	10	UB3160	M10 x 100	5	UB3193	M12 x 220	2
UB3130	M8 x 50	10	UB3163	M10 x 110	5	UB3196	M12 x 240	2
UB3133	M8 x 65	10	UB3166	M10 x 130	5			



Cup Square Hex Bolts & Nuts - Stainless Steel

Retail Bag

Product Codes Begin **UBSSCXD** Product Group **151**

UB6220	M6 x 70	5	UB6248	M10 x 100	5	UB6278	M12 x 130	4
UB6230	M8 x 80	5	UB6251	M10 x 130	5	UB6281	M12 x 150	4
UB6233	M8 x 100	5	UB6254	M10 x 150	5			
UB6236	M8 x 130	5	UB6272	M12 x 100	4			



High Tensile Set Screws, Nuts & Washers BZP

Retail Bag

Product Codes Begin **UB&MHS** Product Group **151**

UB3303	M6 x 25	10	UB3321	M8 x 75	6	UB3351	M12 x 50	4
UB3306	M6 x 40	10	UB3324	M8 x 100	4	UB3354	M12 x 75 HT	4
UB3309	M6 x 50	10	UB3330	M10 x 40	6	UB3357	M12 x 100	4
UB3312	M8 x 25	8	UB3333	M10 x 50	6			
UB3315	M8 x 40	6	UB3336	M10 x 75	4			
UB3318	M8 x 50	6	UB3339	M10 x 100	4			



Roofing Bolts & Nuts BZP

Retail Bag

Product Codes Begin **UB^ARBN** Product Group **151**

Article No.	Size	Bag Qty.			
UB3403	M6 x 12	25	UB3421	M6 x 50	25
UB3406	M6 x 16	25	UB3424	M6 x 60	25
UB3409	M6 x 20	25	UB3427	M6 x 70	25
UB3412	M6 x 25	25	UB3430	M6 x 80	10
UB3415	M6 x 30	25	UB3433	M6 x 100	10
UB3418	M6 x 40	25			

Nuts



Hex Full Nuts DIN 934 BZP

Retail Bag

Product Codes Begin **UBNFFMSZ** Product Group **151**

UB3736	M6	20	UB4009	M12	8
UB4003	M8	20	UB4012	M16	4
UB4006	M10	10	UB4015	M20	2



Hex Full Nuts DIN 934 Stainless Steel

Retail Bag

Product Codes Begin **UBSSNFFMSZ** Product Group **151**

UB6112	M6	20	UB6118	M10	10
UB6115	M8	20	UB6121	M12	8



Nylon Insert Nuts DIN 982 BZP

Retail Bag

Product Codes Begin **UBNIPM** Product Group **151**

UB4030	M6	20	UB4036	M10	10
UB4033	M8	20	UB4039	M12	8



Wing Nuts BZP

Retail Bag

Product Codes Begin **UBESWNSZ** Product Group **151**

UB4042	M6	10	UB4048	M10	6
UB4045	M8	10	UB4051	M12	4

Nut & Washer Packs



Hex Sets, Nuts & Washers BZP

Retail Bag

Product Codes Begin **UB&MHS** Product Group **151**

Article No.	Size	Bag Qty.						
UB3303	M6 x 25	10	UB3321	M8 x 75	6	UB3351	M12 x 50	4
UB3306	M6 x 40	10	UB3324	M8 x 100	4	UB3354	M12 x 75 HT	4
UB3309	M6 x 50	10	UB3330	M10 x 40	6	UB3357	M12 x 100	4
UB3312	M8 x 25	8	UB3333	M10 x 50	6			
UB3315	M8 x 40	6	UB3336	M10 x 75	4			
UB3318	M8 x 50	6	UB3339	M10 x 100	4			



Full Nuts DIN 934 & Washers DIN 125A

Retail Bag

Product Codes Begin **UB9TQTR** Product Group **151**

UB4054	M6	20	UB4063	M12	8
UB4057	M8	20	UB4066	M16	4
UB4060	M10	10	UB4069	M20	2

Washers



Light Washers DIN 125A BZP

Retail Bag

Product Codes Begin **UBWSA** Product Group **151**

UB5003	M6	30	UB5012	M12	20
UB5006	M8	30	UB5015	M16	10
UB5009	M10	20	UB5018	M20	10



Form C Washers BS4320 Stainless Steel

Retail Bag

Product Codes Begin **UBSSWSC** Product Group **151**

UB6050	M6	20	UB6056	M10	20
UB6053	M8	20	UB6059	M12	20



Mudguard Washers BZP

Retail Bag

Product Codes Begin **UBWSMMS** Product Group **151**

UB5203	M5 x 25	20	UB5215	M6 x 25	100
UB5206	M6 x 25	20	UB5218	M8 x 25	100
UB5209	M8 x 25	20	UB5221	M10 x 25	100
UB5212	M10 x 25	20			



Square Plate Washers BZP

Retail Bag

Product Codes Begin **UBVPS** Product Group **151**

Article No.	Size	Bag Qty.
UB5303	M12 X 50	8



Dowty Roof Washers Black

Retail Bag

Product Codes Begin **UBDOWWASH** Product Group **151**

UB5306	M6	20
UB5309	M8	50

Machine Screws

Recessed Pan BZP



Retail Bag

Product Codes Begin **UBMMS** Product Group **151**

UB3603	M4 x 12	10	UB3615	M5 x 40	10	UB3627	M6 x 50	10
UB3606	M4 x 20	10	UB3618	M5 x 50	10			
UB3609	M4 x 25	10	UB3621	M6 x 25	10			
UB3612	M5 x 25	10	UB3624	M6 x 40	10			



Electrical Screws Recessed Raised NP

Retail Bag

Product Codes Begin **UBZP** Product Group **151**

UB3703	M3.5 x 40	10	UB3712	M3.5 x 50	40
UB3706	M3.5 x 40	40	UB3715	M3.5 x 75	10
UB3709	M3.5 x 50	10	UB3718	M3.5 x 75	40

Nails & Pins



Panel Pins

Retail Bag

Product Codes Begin **UB9PP** Product Group **151**

Article No.	Size	Bag Qty.			
UB2515	20 x 1.6mm	100g	UB2527	30 x 1.6mm	100g
UB2518	25 x 1.6mm	100g	UB2530	40 x 1.6mm	100g
UB2521	30 x 1.6mm	100g			
UB2524	40 x 1.6mm	100g			



Veneer Pins

Retail Bag

Product Codes Begin **UB9VP** Product Group **151**

UB2533	20mm	50g
UB2536	25mm	50g



Galvanised Staples

Retail Bag

Product Codes Begin **UB9GALVSTAP** Product Group **151**

UB6303	15mm	100gm
UB6306	20mm	100gm
UB6309	25mm	100gm



Masonry Nails

Retail Bag

Product Codes Begin **UBAMNH** Product Group **151**

UB8990	25 x 2.5	30	UB8909	50 x 3.0	14
UB8903	30 x 2.5	25	UB8912	60 x 3.0	12
UB8906	40 x 2.5	20	UB8915	75 x 3.5	7



Polytop Nails A4 Stainless Steel

Retail Bag

Product Codes Begin **UBPOLY** Product Group **151**

UB8931	30mm Black	25
UB8937	30mm White	25
UB8934	40mm Black	25
UB8940	40mm White	25



General Accessories



Copper Slate Strap

Retail Bag

Product Codes Begin **UB9CUSLAC** Product Group **151**

Article No.	Size	Bag Qty.
UB7027	150mm	25



Jointing Blocks

Retail Bag

Product Codes Begin **UB9HBLOCK** Product Group **151**

UB7000	Beige	10
UB7003	Black	10
UB7006	Brown	10
UB7009	White	10



Knockdown Blocks

Retail Bag

Product Codes Begin **UB9KDBLOCK** Product Group **151**

UB7012	White	4
--------	-------	---



Shelf Supports

Retail Bag

Product Codes Begin **UB9NISS** Product Group **151**

UB7015	White	25
--------	-------	----



Glass Plates

Retail Bag

Product Codes Begin **UB9HQGLASS** Product Group **151**

UB7018	25mm	2
--------	------	---



Straining Eye Bolts

Retail Bag

Product Codes Begin **UB9NISS** Product Group **151**

UB7035	White	25
--------	-------	----





Worktop Jointing Bolts

Retail Bag

Product Codes Begin **UBZWTCLAMP** Product Group **151**

Article No.	Size	Bag Qty.
UB7044	65mm	2
UB7047	150mm	2

Sanitary Fixing Packs



Sanitary Fixings

Retail Bag

Product Codes Begin **UBNWCW / UBNBFS** Product Group **151**

UB8945	M10 x 140	2
UB8948	M6 x 70	2

Metal Anchors



Loose Bolt Shield Anchors ZYP

Retail Bag

Product Codes Begin **UBBALB** Product Group **151**

UB8000	M6 x 10	10	UB8012	M8 x 40	6	UB8024	M10 x 75	4
UB8003	M6 x 25	10	UB8015	M10 x 10	4	UB8027	M12 x 10	2
UB8006	M8 x 10	6	UB8018	M10 x 25	4	UB8030	M12 x 25	2
UB8009	M8 x 25	6	UB8021	M10 x 50	4	UB8033	M12 x 60	2



Projecting Bolt Shield Anchors ZYP

Retail Bag

Product Codes Begin **UBBAMNM** Product Group **151**

UB8039	M6 x 10	6	UB8048	M10 x 30	4
UB8042	M8 x 15	6	UB8051	M10 x 70	4
UB8045	M8 x 80	4	UB8054	M12 x 50	2



Eye Bolt Shield Anchors ZYP

Retail Bag

Product Codes Begin **UBAEBM** Product Group **151**

UB8060	M8	4
--------	----	---



Through Bolts ZYP

Retail Bag

Product Codes Begin **UBAWA** Product Group **151**

Article No.	Size	Bag Qty.						
UB8100	M8 x 65	6	UB8109	M10 x 90	4	UB8118	M16 x 125	2
UB8103	M8 x 100	6	UB8112	M10 x 120	4			
UB8106	M10 x 75	4	UB8115	M12 x 100	4			



Hex Sleeve Anchors ZYP

Retail Bag

Product Codes Begin **UBSLN** Product Group **151**

UB8200	M8 x 85	6	UB8209	M12 x 75	4
UB8203	M10 x 75	4	UB8212	M12 x 100	4
UB8206	M10 x 100	4			



Concrete Bolts Zinc & Clear Passivated



Article No.	Size	Head Style.	Bag Qty.
UB8300	M6[8] x 50	Hex Flange	6
UB8303	M6[8] x 75	Hex Flange	6
UB8306	M6[8] x 100	Hex Flange	4
UB8309	M8[10] x 60	Hex Head	4
UB8312	M8[10] x 75	Hex Head	4
UB8315	M8[10] x 100	Hex Head	4
UB8317	M8[10] x 150	Hex Head	4
UB8318	M10[12] x 75	Hex Head	4
UB8321	M10[12] x 100	Hex Head	4
UB8324	M10[12] x 150	Hex Head	2
UB8327	M6[8] x 75	Csk Head	6
UB8330	M6[8] x 100	Csk Head	4
UB8333	M6[8] x 50	Eye Bolt	2

Light Duty Fixings



Concrete Screws

Retail Bag

Product Codes Begin **UBCS** Product Group **151**

UB8700	M7.5 x 60	20
UB8703	M7.5 x 80	20
UB8706	M7.5 x 100	20
UB8709	M7.5 x 120	10
UB8712	M7.5 x 150	10



Nylon Hammer Screws

Retail Bag

Product Codes Begin **UBNHS** Product Group **151**

Article No.	Size	Bag Qty.			
UB8427	M6 x 40	20	UB8436	M8 x 100	10
UB8430	M6 x 60		UB8439	M8 x 120	10
UB8433	M8 x 80	10			

Plugs



Premium Plastic Wall Plugs

Retail Bag

Product Codes Begin **UBJCP** Product Group **151**

UB8500	M6 Red	50
UB8503	M7 Brown	50



Nylon Wall Plugs

Retail Bag

Product Codes Begin **UBNPP** Product Group **151**

UB8509	M6	40
UB8512	M8	40
UB8515	M10	20



Universal Cavity & Solid Wall Plugs

Retail Bag

Product Codes Begin **UBNUP** Product Group **151**

UB8521	M6	40
UB8524	M8	40



Cavity Fixings



Rosett Cavity Fixings

Retail Bag

Product Codes Begin **UBRR** Product Group **151**

Article No.	Size	Bag Qty.	Article No.	Size	Bag Qty.
UB8600	M5 x 55 Blue	6	UB8606	M5 x 65 Red	6
UB8603	M5 x 80 Blue	6	UB8609	M5 x 90 Red	6



Plasterboard Fixings Metal

Retail Bag

Product Codes Begin **UBJJP** Product Group **151**

UB8615		6
UB8618		20



Plasterboard Fixings Plastic

Retail Bag

Product Codes Begin **UBJJP** Product Group **151**

UB8621		6
UB8624		20



Hollow Wall Anchors ZYP

Retail Bag

Product Codes Begin **UBLHWA** Product Group **151**

UB8630	M4 x 45	10
UB8633	M5 x 45	10
UB8636	M6 x 60	10



Spring Toggles ZYP

Retail Bag

Product Codes Begin **UBLST** Product Group **151**

UB8642	M5 x 50	6	UB8648	M6 x 75	6
UB8645	M5 x 75	6			



Self Drilling Screws

Light Self Drilling Screws c/w 16mm Washer

Retail Bag

Product Codes Begin **UBMFL** Product Group **151**

Article No.	Size	Bag Qty.			
UB8800	M5.5 x 25	30	UB8806	M5.5 x 38	20
UB8803	M5.5 x 32	30	UB8809	M5.5 x 50	20



Light Self Drilling Screws

Retail Bag

Product Codes Begin **UBMFL** Product Group **151**

UB8815	M5.5 x 25	30
UB8818	M5.5 x 38	30
UB8821	M5.5 x 50	30



Heavy Self Drilling Screws c/w 16mm Washer

Retail Bag

Product Codes Begin **UBMFH** Product Group **151**

UB8827	M5.5 x 32	20
UB8830	M5.5 x 40	20
UB8833	M5.5 x 50	20



EDPM Bonded Washers

Retail Bag

Product Codes Begin **UBMFW** Product Group **151**

UB8839	M16	50
UB8842	M19	50



Gash Point Screws c/w 16mm Washer

Retail Bag

Product Codes Begin **UBGFP** Product Group **151**

UB8848	M6.3 x 32	30
UB8851	M6.3 x 45	30



Stitching Screws

Retail Bag

Product Codes Begin **UBSS** Product Group **151**

Article No.	Size	Bag Qty.
UB8857	M6.3 x 25	30



Light Self Drilling Screws Woodfix

Retail Bag

Product Codes Begin **UBWFL** Product Group **151**

UB8863	M5.5 x 40	30	UB8872	M5.5 x 80	20
UB8866	M5.5 x 50	30	UB8875	M5.5 x 110	20
UB8869	M5.5 x 60	20			



Heavy Self Drilling Screws Woodfix

Retail Bag

Product Codes Begin **UBWFH** Product Group **151**

UB8881	M5.5 x 60	20
UB8884	M5.5 x 85	20
UB8887	M5.5 x 109	20



Wafer Head Screws

Retail Bag

Product Codes Begin **UBWH** Product Group **151**

UB8893	M4.2 x 13	30
--------	-----------	----



Hex Drive Magnetic Socket

Retail Bag

Product Codes Begin **UBMF** Product Group **151**

UB8899	5/16"	1
--------	-------	---

Insulation Fixings

Bigtwist Insulation Nails

Retail Bag

Product Codes Begin **UBTC** Product Group **151**

UB8921	165 x 8	10
UB8924	195 x 8	10

SP Clampack Range of Fasteners

BZP Countersunk Head Recessed
Hardened Steel Twinthread Woodscrews



Product Codes Begin **9SPATQTQ** Product Group **5003**

Article No.	Box Size	Box Qty.	Pack Qty.								
SP901	4 × 1/2	10	45	SP923	6 × 1.1/4	10	25	SP943	8 × 2	10	10
SP903	6 × 1/2	10	40	SP925	7 × 1.1/4	10	20	SP945	10 × 2	10	8
SP905	4 × 5/8	10	35	SP927	8 × 1.1/4	10	20	SP947	8 × 2.1/2	10	6
SP907	6 × 5/8	10	35	SP929	10 × 1.1/4	10	10	SP949	10 × 2.1/2	10	6
SP909	4 × 3/4	10	35	SP931	6 × 1.1/2	10	20	SP951	12 × 2.1/2	10	6
SP911	6 × 3/4	10	35	SP933	8 × 1.1/2	10	18	SP953	10 × 3	10	4
SP913	8 × 3/4	10	30	SP935	10 × 1.1/2	10	10	SP954	12 × 2	10	6
SP915	6 × 1	10	30	SP936	12 × 1.1/2	10	8	SP955	12 × 3	10	4
SP917	7 × 1	10	25	SP937	8 × 1.3/4	10	15	SP957	10 × 3.1/2	10	4
SP919	8 × 1	10	25	SP939	10 × 1.3/4	10	10	SP958	10 × 4	10	4
SP921	10 × 1	10	15	SP941	6 × 2	10	10	SP959	12 × 4	10	4

ZYP Countersunk Head Recessed
Hardened Steel Single Thread Woodscrews



Product Codes Begin **9SPACHIPPY** Product Group **5003**

SP201	3.0 × 12	10	48	SP217	4.0 × 40	10	18	SP236	5.0 × 50	10	8
SP203	3.0 × 20	10	35	SP218	4.0 × 45	10	15	SP238	5.0 × 60	10	6
SP205	3.5 × 12	10	40	SP219	4.0 × 50	10	10	SP239	5.0 × 70	10	4
SP207	3.5 × 20	10	35	SP220	4.0 × 60	10	6	SP241	5.0 × 80	10	4
SP208	3.5 × 25	10	30	SP223	4.5 × 30	10	10	SP243	5.0 × 100	10	4
SP209	3.5 × 30	10	25	SP225	4.5 × 40	10	10	SP245	6.0 × 50	10	6
SP210	3.5 × 40	10	20	SP227	4.5 × 50	10	8	SP246	6.0 × 60	10	6
SP213	4.0 × 20	10	30	SP232	5.0 × 30	10	10	SP247	6.0 × 70	10	4
SP214	4.0 × 25	10	25	SP234	5.0 × 40	10	10	SP249	6.0 × 80	10	4
SP215	4.0 × 30	10	20	SP235	5.0 × 45	10	10	SP251	6.0 × 100	10	4

Black Japanned Round Head Slotted Woodscrews



Product Codes Begin **9SPAWSSRJ** Product Group **5003**

SP055	6 × 3/4	10	40	SP065	10 × 1	10	20	SP073	10 × 1.1/2	10	15
SP057	8 × 3/4	10	25	SP067	8 × 1.1/4	10	20	SP075	8 × 2	10	15
SP061	6 × 1	10	35	SP069	10 × 1.1/4	10	15	SP076	10 × 2	10	10
SP063	8 × 1	10	25	SP071	8 × 1.1/2	10	20				



SP Clampack Range of Fasteners

Brass Countersunk Head Slotted Woodscrews



Product Codes Begin **9SPAWSBC** Product Group **5003**

Article No.	Box Qty. Size	Pack Qty.									
SP097	2 × 3/8	10	50	SP115	8 × 3/4	10	20	SP127	8 × 1.1/2	10	20
SP101	2 × 1/2	10	50	SP117	6 × 1	10	35	SP129	10 × 1.1/2	10	15
SP103	4 × 1/2	10	50	SP118	7 × 1	10	30	SP130	10 × 1.3/4	10	10
SP105	6 × 1/2	10	45	SP119	8 × 1	10	30	SP131	8 × 2	10	15
SP107	8 × 1/2	10	20	SP121	6 × 1.1/4	10	30	SP135	10 × 2	10	10
SP109	4 × 5/8	10	40	SP122	7 × 1.1/4	10	25	SP137	10 × 2.1/2	10	10
SP111	4 × 3/4	10	30	SP123	8 × 1.1/4	10	25	SP138	12 × 2.1/2	10	4
SP113	6 × 3/4	10	40	SP125	10 × 1.1/4	10	15				

Brass Round Head Slotted Woodscrews



Product Codes Begin **9SPAWSBR** Product Group **5003**

SP145	4 × 1/2	10	50	SP155	8 × 3/4	10	20	SP163	8 × 1.1/4	10	20
SP147	6 × 1/2	10	30	SP157	6 × 1	10	35	SP165	8 × 1.1/2	10	20
SP153	6 × 3/4	10	40	SP159	8 × 1	10	30	SP167	10 × 1.1/2	10	15

Chrome Plated Brass Raised Head Slotted Woodscrews



Product Codes Begin **9SPAWCPRSD** Product Group **5003**

SP170	6 × 3/4	10	26	SP173	8 × 1.1/4	10	16
SP171	6 × 1	10	24	SP174	8 × 1.1/2	10	12
SP172	8 × 1	10	20	SP176	10 × 2	10	6

Chrome Plated Steel Dome Top Mirror Screws



Product Codes Begin **9SPACDTSWS** Product Group **5003**

SP896	8 × 1	10	4
SP897	8 × 1.1/4	10	4
SP898	8 × 1.1/2	10	4

Brass Surface Screw Cups



Product Codes Begin **9SPABSURF** Product Group **5003**

SP808	6G	10	30
SP810	7-8G	10	30
SP812	9-10G	10	30



SP Clampack Range of Fasteners

Nickel Plated Brass Surface Screw Cups



Product Codes Begin **9SPABSURFNP** Product Group **5003**

Article No.	Box Qty. Size	Pack Qty.
SP814	6 g	10 30
SP816	7 - 8g	10 30
SP818	9 - 10g	10 30

Domecaps



Product Codes Begin **9SPADOMETOP** Product Group **5003**

Article No.	Box Qty. Colour	Pack Qty.
SP1102	Chrome	10 6
SP1104	White	10 20
SP1108	Dk Brown	10 20

Plustops



Product Codes Begin **9SPAPLUSTOP** Product Group **5003**

SP1122	White	10 50
SP1124	Light Brown	10 50

BZP Pan Head Recessed Self Tapping Screws AB



Product Codes Begin **9SPABZPSTS** Product Group **5003**

Article No.	Box Qty. Size	Pack Qty.
SP9108	6 × 1/2	10 28
SP9112	6 × 3/4	10 24
SP9114	6 × 1	10 20
SP9125	8 × 1/2	10 22
SP9128	8 × 3/4	10 18
SP9130	8 × 1	10 18
SP9132	8 × 1.1/4	10 14
SP9134	8 × 1.1/2	10 11
SP9143	10 × 3/4	10 15
SP9144	10 × 1	10 12
SP9148	10 × 1.1/2	10 8
SP9152	10 × 2	10 4

BZP Pan Head Machine Screws



Product Codes Begin **9SPASMTS** Product Group **5003**

SP1422	M5 × 25mm	10 4
SP1424	M5 × 40mm	10 3
SP1426	M5 × 50mm	10 2
SP1428	M6 × 25mm	10 4
SP1430	M6 × 40mm	10 3
SP1432	M6 × 50mm	10 2



SP Clampack Range of Fasteners

BZP Steel Screw Eyes



Product Codes Begin **9SPASSEYE** Product Group **5003**

Article No.	Box Qty. Size	Pack Qty.					
SP833	30mm	10	15	SP839	55mm	10	5
SP835	40mm	10	10	SP841	75mm	10	2
SP837	45mm	10	5				

EB Steel Screw Eyes



Product Codes Begin **9SPASSEYE** Product Group **5003**

SP830	14mm	10	18
-------	------	----	----

BZP Steel M Hooks



Product Codes Begin **9SPASMHK** Product Group **5003**

SP821	60mm	10	5
SP823	80mm	10	4

EB Shouldered Cup Hooks



Product Codes Begin **9SPACUPHK** Product Group **5003**

SP1208	20mm	10	8	SP1212	32mm	10	6
SP1210	25mm	10	8	SP1214	38mm	10	4

White Shouldered Cup Hooks



Product Codes Begin **9SPACUPHK** Product Group **5003**

SP1200	20mm	10	6	SP1204	32mm	10	4
SP1202	25mm	10	6	SP1206	38mm	10	3

EB Square Hooks



Product Codes Begin **9SPACUPHK** Product Group **5003**

SP1220	25mm	10	8
SP1222	32mm	10	6



SP Clampack Range of Fasteners

White Square Hooks



Product Codes Begin **9SPACUPHK** Product Group **5003**

Article No.	Size	Box Qty.	Pack Qty.
SP1216	25mm	10	6

Picture Wire



Product Codes Begin **9SPAPICHK** Product Group **5003**

SP1270	3.5mm	10	1
--------	-------	----	---

Picture Hooks



Product Codes Begin **9SPAPICHK** Product Group **5003**

SP1272	Small	10	6	SP1276	Double	10	3
SP1274	Large	10	5				

Picture Hook Pins



Product Codes Begin **9SPAPICHK/1278** Product Group **5003**

SP1278	Standard	10	6
--------	----------	----	---

BZP Curtain Wire Hooks & Eyes



Product Codes Begin **9SPAPICHK/1260** Product Group **5003**

SP1260	Standard	10	15
--------	----------	----	----

BZP Gate Hooks & Eyes



Product Codes Begin **9SPAGATEHK** Product Group **5003**

SP1268	50mm	10	3
--------	------	----	---



SP Clampack Range of Fasteners

Steel Veneer Pins



Product Codes Begin **9SPAVP** Product Group **5003**

Article No.	Size	Box Qty.	Weight per Bag
SP1334	15mm (30g)	10	30g
SP1336	20mm (30g)	10	30g
SP1338	25mm (30g)	10	30g

Steel Panel Pins



Product Codes Begin **9SPAPP** Product Group **5003**

SP1322	15mm (50g)	10	50g	SP1328	30mm (50g)	10	50g
SP1324	20mm (50g)	10	50g	SP1330	40mm (50g)	10	50g
SP1326	25mm (50g)	10	50g				

Brass Panel Pins



Product Codes Begin **9SPABPP** Product Group **5003**

SP1292	15mm (25g)	10	25g	SP1296	25mm (25g)	10	25g
SP1294	20mm (25g)	10	25g				

Blued Cut Tacks



Product Codes Begin **9SPACT** Product Group **5003**

SP1298	10mm (50g)	10	50g	SP1304	20mm (50g)	10	50g
SP1302	16mm (50g)	10	50g	SP1306	25mm (50g)	10	50g

Coppered Hardboard Pins



Product Codes Begin **9SPAHP** Product Group **5003**

SP1340	20mm (30g)	10	30g
--------	------------	----	-----

Corrugated Joint Fasteners



Product Codes Begin **9SPACFAST** Product Group **5003**

Article No.	Size	Box Qty.	Pack Qty.
SP1480	5/8x5	10	15

Wire Netting

Galvanised Before Manufacture

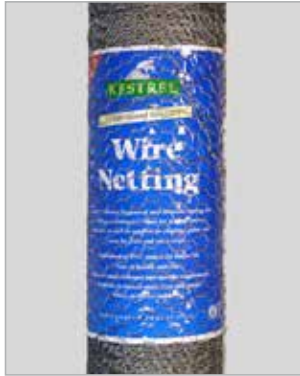

Product Codes Begin **9GALVWN5/10** Product Group **5048**

Article No.	Roll Length	Height x Mesh	Size mm							
OJ108377	5m	600 × 13		OJ243139	5m	600 × 50		OJ108322	10m	900 × 25
OJ127415	5m	900 × 50		OJ108285	10m	600 × 13		OJ108339	10m	1200 × 25
OJ243108	5m	900 × 13		OJ108292	10m	900 × 13		OJ108346	10m	600 × 50
OJ243115	5m	600 × 25		OJ108308	10m	1200 × 13		OJ108353	10m	900 × 50
OJ243122	5m	900 × 25		OJ108315	10m	600 × 25		OJ108360	10m	1200 × 50

Product Codes Begin **9GALVWN25/50** Product Group **5046**



OJ027999	25m	600 × 13		OJ028255	50m	900 × 13	
OJ028002	25m	900 × 13		OJ028262	50m	1200 × 13	
OJ028019	25m	1200 × 13		OJ028415	50m	600 × 25	
OJ028026	25m	1800 × 13		OJ028439	50m	900 × 25	
OJ028033	25m	300 × 25		OJ028453	50m	1200 × 25	
OJ028057	25m	600 × 25		OJ028460	50m	1800 × 25	
OJ028071	25m	900 × 25		OJ028651	50m	900 × 38	
OJ028088	25m	1200 × 25		OJ028705	50m	450 × 50	
OJ028095	25m	1800 × 25		OJ028712	50m	600 × 50	
OJ028156	25m	600 × 50		OJ028736	50m	900 × 50	
OJ028170	25m	900 × 50		OJ028743	50m	1200 × 50	
OJ028187	25m	1200 × 50		OJ028767	50m	1800 × 50	
OJ028200	25m	1800 × 50					

A Kestrel wire netting merchandiser is available to display this range of products.

Dimensions: H 1,950mm W 1,260mm (W 1,560mm including optional mesh panel display) D 680mm. Please contact your local sales office for more details.

Screened Netting

Product Codes Begin **9TQSCREED** Product Group **5046**

OJ523705	50m	900 × 50
OJ523712	50m	1200 × 50

Rabbit Netting

Product Codes Begin **9GALVWNR** Product Group **5046**

OJ422558	50m	1050 × 31
----------	-----	-----------

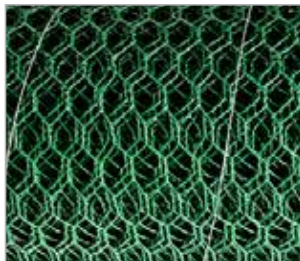

Garden Products

Green PVC Wire Netting

Product Codes Begin **9GNWN10** Product Group **5051**

OJ238562	10m	500 × 13		OJ238531	10m	1000 × 13
OJ238579	10m	500 × 25		OJ238548	10m	1000 × 25
OJ238586	10m	500 × 50		OJ238555	10m	1000 × 50

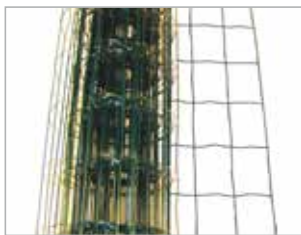

Green Trimfence

Product Codes Begin **9TRIMF** Product Group **5051**

Article No.	Roll Length	Height mm
16691	10m	900
16692	10m	1200



Green Border Fence

Product Codes Begin **9NORF** Product Group **5051**

OJ243184	10m	250	OJ108513	10m	650
OJ243191	10m	400	OJ243207	10m	900

Chain Link Fencing

Supplied with Line Wires:

2 Line Wires – 900mm

3 Line Wires – 1,200mm, 1,400mm & 1,800mm

4 Line Wires – 2,400mm & 2,750mm



Green PVC Coated

Product Codes Begin **9GNCLF** Product Group **5045**

Article No.	Length per Coil	Size
OJ108551	10m	900 × 50 × 2.50 / 1.70
OJ108568	10m	1200 × 50 × 2.50 / 1.70
OJ108575	25m	900 × 50 × 2.50 / 1.70
OJ029078	25m	900 × 50 × 3.15 / 2.24
OJ108582	25m	1200 × 50 × 2.50 / 1.70
OJ029085	25m	1200 × 50 × 3.15 / 2.24
OJ029023	25m	1400 × 50 × 2.50 / 1.70
OJ394800	25m	1500 × 50 × 3.15 / 2.24
OJ108599	25m	1800 × 50 × 2.50 / 1.70
OJ029108	25m	1800 × 50 × 3.15 / 2.24

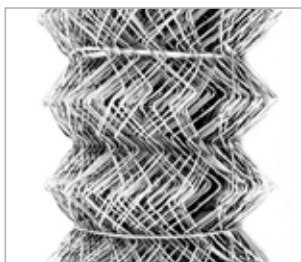

Galvanised

Product Codes Begin **9GALVCLF** Product Group **5045**

OJ223063	12.5m	900 × 50 × 2.00	OJ025360	25m	1200 × 50 × 2.50
OJ223070	12.5m	1200 × 50 × 2.00	OJ025377	25m	1400 × 50 × 2.50
OJ025353	25m	900 × 50 × 2.50	OJ025384	25m	1800 × 50 × 2.50

Chain Link Fencing

Spare Line Wires



Green PVC Coated

Product Codes Begin **9GNCLFLW** Product Group **5045**

Article No.	Roll Length	Size			
OJ108605	25m	3.15mm	OJ029429	75m	3.15mm
OJ029412	50m	3.15mm			



Galvanised

Product Codes Begin **9GALVCLFLW** Product Group **5045**

OJ108636	25m	3.00mm	OJ025476	75m	3.15mm
OJ025469	50m	3.00mm			

Wire in Coils

Galvanised



Product Codes Begin **9GALVW** Product Group **5050**

Article No.	Diameter Wire	Approx Length
-------------	---------------	---------------

25kg Coils

OJ027524	3.15mm	410
OJ027517	4.00mm	254

5kg Coils

OJ027661	1.25mm	519
OJ027654	1.60mm	316
OJ027647	2.00mm	203
OJ027630	2.50mm	130
OJ027623	3.15mm	82

10kg Coils

OJ027579	3.15mm	164
----------	--------	-----

500g Coils

OJ119472	0.71mm	161
OJ119465	0.90mm	100
OJ119458	1.00mm	81
OJ119441	1.25mm	51
OJ119434	1.60mm	31
OJ119427	2.00mm	20



Green PVC Coated Tying Wire

Product Codes Begin **9GNTW** Product Group **5045**

Article No.	Size	Coil Size
OJ238524	2.00/1.40mm	34m/500g

Product Codes Begin **9GNTW** Product Group **5051**

Article No.	Size	Coils per Box
OJ284989	100m x 1mm	10



Galvanised Stock Fence

Product Codes Begin **9HJSFOWL** Product Group **5052**

Article No.	Roll Length	Size
OJ242804	50mm	C8 / 80 / 15

• 800mm High • 8 Line Wires • 150mm Between Vertical Strands



Light Gauge Welded Mesh Galvanised

6 Metre Rolls

Product Codes Begin **9GALVT6** Product Group **36**

Article No.	Height x Mesh x Mesh x Gauge	Size mm
9/3/9	900 x 13 x 13 x 19g	12/3/6
9/3/5/9	900 x 13 x 25 x 19g	12/5/6
9/5/9	900 x 25 x 25 x 19g	9/0/6
9/3/6	900 x 13 x 13 x 16g	9/6/22
		1200 x 13 x 13 x 16g
		1200 x 25 x 25 x 16g
		900 x 50 x 50 x 16g
		900 x 6 x 6 x 22g

30 Metre Rolls

Product Codes Begin **9GALVT30** Product Group **36**

9/3/9	900 x 13 x 13 x 19g	9/5/9	900 x 25 x 25 x 19g
9/3/5/9	900 x 13 x 25 x 19g	12/5/6	1200 x 25 x 25 x 16g



Green PVC Coated

6 Metre Rolls

Product Codes Begin **9GNT6** Product Group **36**

OJ238494	900 x 13 x 13 x 20 / 23
OJ238500	900 x 25 x 25 x 15 / 17
OJ238517	900 x 50 x 50 x 12 / 14

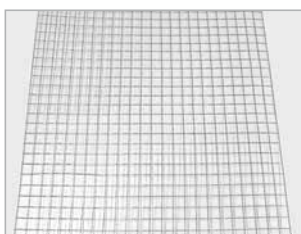

Handymesh Panels 36" x 24"

Note: Minimum order quantity = 1 pack of 10 panels.

Galvanised

Product Codes Begin **9HANDY** Product Group **36**

Article No.	Mesh x Mesh x Gauge	Size inch	
OJ108704	1/2 x 1/2 x 19g	OJ417790	1/4 x 1/4 x 22g
OJ108711	1 x 1 x 16g	OJ793092	1/2 x 1 x 19g

Green PVC

OJ108728	2 x 2 x 10g
----------	-------------

Heavy Welded Mesh

Self Colour

Product Codes Begin **5** Product Group **35**

Article No.	Roll Length	Height x Mesh	Size mm
OJ315706	4' x 8'	2 x 2 x 6g	
OJ315713	4' x 8'	3 x 3 x 6g	
OJ315720	4' x 8'	1 x 1 x 8g	
OJ315737	4' x 8'	2 x 1 x 8g	
OJ315799	4' x 8'	2 x 2 x 8g	
OJ315812	4' x 8'	3 x 1/2 x 8g	
OJ315805	4' x 8'	3 x 3 x 8g	
OJ315867	4' x 8'	1 x 1 x 10g	
OJ315881	4' x 8'	1.1/2 x 1.1/2 x 10g	
OJ315874	4' x 8'	2 x 1 x 10g	
OJ315959	4' x 8'	2 x 2 x 10g	
OJ315997	4' x 8'	3 x 1/2 x 10g	
OJ315980	4' x 8'	3 x 3 x 10g	
OJ316000	4' x 8'	4 x 4 x 10g	
OJ316055	4' x 8'	1 x 1 x 12g	
OJ316093	4' x 8'	2 x 1 x 12g	
OJ316130	4' x 8'	2 x 2 x 12g	
OJ316161	4' x 8'	3 x 1/2 x 12g	
OJ316581	4' x 8'	1/2 x 1/2 x 16g	
OJ315836	6' x 3'	1 x 1 x 10g	
OJ315911	6' x 3'	2 x 2 x 10g	
OJ316154	6' x 3'	3 x 1/2 x 12g	
OJ453556	6' x 3'	3 x 3 x 10g	

Galvanised

Product Codes Begin **5G** Product Group **35**

OJ316277	4' x 8'	3 x 3 x 6g	OJ316499	4' x 8'	3 x 1/2 x 12g
OJ316338	4' x 8'	2 x 2 x 8g	OJ316260	6' x 3'	3 x 3 x 6g
OJ316376	4' x 8'	1 x 1 x 10g	OJ316284	6' x 3'	3 x 6 x 6g
OJ316420	4' x 8'	2 x 2 x 10g	OJ316369	6' x 3'	1 x 1 x 10g
OJ316444	4' x 8'	3 x 3 x 10g	OJ454454	6' x 3'	2 x 2 x 10g
OJ316468	4' x 8'	1 x 1 x 12g	OJ454683	6' x 3'	1 x 1 x 12g
OJ316482	4' x 8'	2 x 2 x 12g			



Landscape Fabric

Product Codes Begin **9LANDSCAPE** Product Group **5051**

Article No.	Description
21350014	1 x 14m 50g Landscape Fabric

- Cost-effective weed suppressant • Free from harmful chemicals • Promotes root growth by maintaining soil temperature and moisture
- Ideal for use under decorative chippings or mulch in borders



Barbed Wire



Galvanised Rypoint on Wooden Reels

Product Codes Begin **9BARBWOODR** Product Group **5047**

Article No.	Roll Length	Size/Colour
OJ493794	200m	2.5 × 2PLY × 4PT Grey



Galvanised Lasso High Tensile

Product Codes Begin **9BARBWLASO** Product Group **5047**

OJ071077	200m	1.70mm × 2PLY × 4PT
----------	------	---------------------



Galvanised Motto

Product Codes Begin **9MBARBW** Product Group **5047**

OJ243238	200m	1.60mm × 2PLY × 4PT
----------	------	---------------------



Galvanised Garden Barbed Wire

Product Codes Begin **9GBARB** Product Group **5051**

Article No.	Length per Coil	Size
OJ108810	15m	2.50mm × 2PLY × 4PT



Razor Wire

Product Codes Begin **9BARBTAPE** Product Group **5047**

Article No.	Roll Length	Size
OJ421780	50m	B50 Medium Razor Barb



Concertina Type

Article No.	Roll Diameter	Size
OJ421803	730mm	SZ3562 Medium Razor Barb
OJ421810	450mm	SZ4562 Medium Razor Barb

Metalwork for Fencing

Black Coated Intermediate Standard

Should be placed at 3 metre intervals

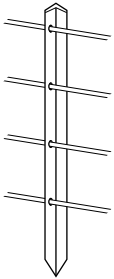

Product Codes Begin **9FPIS** Product Group **5057**

Article No.	For CLF Height	Size	Article No.	For CLF Height	Size
OJ070964	0.9m	1.50 × 40 × 40 × 5	OJ024820	1.40m	2.00 × 40 × 40 × 5
OJ070971	1.20m	1.80 × 40 × 40 × 5	OJ024837	1.80m	2.60 × 40 × 40 × 5

Black Coated Terminal Straining Pillars

Product Codes Begin **9FPTSP** Product Group **5057**

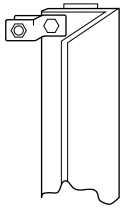

OJ024844	0.9m	1.50 × 50 × 50 × 6 + 1 Stay	OJ024868	1.40m	2.00 × 50 × 50 × 6 + 1 Stay
OJ024851	1.20m	1.80 × 50 × 50 × 6 + 1 Stay	OJ024875	1.80m	2.50 × 50 × 50 × 6 + 1 Stay

Black Coated Corner Straining Pillars

Product Codes Begin **9FPCSP** Product Group **5057**

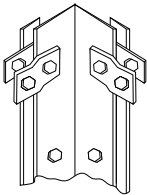

OJ024752	0.90m	1.50 × 50 × 50 × 6 + 2 Stay	OJ526294	1.40m	2.00 × 50 × 50 × 6 + 2 Stay
OJ024769	1.20m	1.80 × 50 × 50 × 6 + 2 Stay	OJ024783	1.80m	2.50 × 50 × 50 × 6 + 2 Stay

Black Coated Two-Way Straining Pillars

Product Codes Begin **9FPTWSP** Product Group **5057**

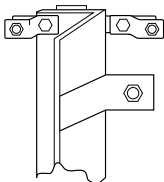

OJ024899	1.20m	1.80 × 50 × 50 × 6 + 2 Stay
OJ024912	1.80m	2.50 × 50 × 50 × 6 + 2 Stay

Stretcher Bar Sets

Product Codes Begin **9BPACBSB** Product Group **5057**



Article No.	For CLF Height	Contents	Other Sizes	
			0.90m	Other Sizes
OJ078861	0.90m	Galvanised Stretcher Bars	2	2
OJ078878	1.20m	Galvanised Angle Cleats	4	6
OJ078885	1.40m	Galvanised Straining Eye Bolts 12 × 3/8 FT	4	6
OJ078892	1.80m	BZP M8 × 25 Bolts & Nuts	4	6

Bags of Fittings for Stretcher Bars

Product Codes Begin **9SBSFIT** Product Group **5057**



Article No.	Contents	Qty.
SBBZHRH	Galvanised Angle Cleats	2
	Galvanised Straining Eye Bolts 12 × 3/8 FT	2
	BZP M8 × 25 Bolts & Nuts	2



Stretcher Bar Only

Product Codes Begin **9SBSSB** Product Group **5057**

Article No.	For CLF Height	Article No.	Size
OJ053639	0.90m	OJ053660	1.80m
OJ053646	1.20m	OJ053677	2.40m
OJ053653	1.40m		



Black Coated Bent over Arms

Half twisted for fitting to concrete posts

Product Codes Begin **9FPBOA** Product Group **5057**

Article No.	Size
OJ024738	700 × 30 × 6



Galvanised Winders

Product Codes Begin **9FPGW** Product Group **5057**

Article No.
4256



Galvanised Angle Cleats

Product Codes Begin **9BSAC** Product Group **5057**

Article No.	Size
OJ053622	38 × 38 × 30 × 5

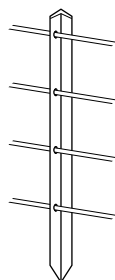

Self Colour Netting Stakes

Product Codes Begin **9NSTAK** Product Group **5057**

Article No.	For Fencing Height	Size
0.6m SC	0.60m	1.20 × 40 × 40 × 3.00
0.9m SC	0.90m	1.50 × 40 × 40 × 3.00
1.2m SC	1.20m	1.80 × 40 × 40 × 3.00

Wire Netting Fasteners



BZP 16 × 10mm

Product Codes Begin **9BZWNF** Product Group **5057**

Article No.	Box Qty.
64561	200



Sheradised Heavy Duty

Product Codes Begin **9HWNF** Product Group **5057**

OJ243030	100
----------	-----



Pliers For Wire Netting Fasteners

Product Codes Begin **9GREYMIP** Product Group **5057**

OJ029863	1 Pair
----------	--------



Galvanised Gerrard Hog Rings

Product Codes Begin **9HOG** Product Group **5057**

OJ242828	1000
----------	------



Gerrard Hog Ring Pliers

Product Codes Begin **9HOG** Product Group **5057**

OJ242811	1 Pair
----------	--------



Fence Pins For Barrier Fence 1200mm S/C

Product Codes Begin **9FENCE** Product Group **5057**

OJ583853	1
----------	---



Straining Eye Bolts



BZP Folded Eye

Fully Threaded

Product Codes Begin **9SEYEBZP** Product Group **5053**

Article No.	Size	Box Qty.
EU920BZ2	8 × 3/8	20
EU925BZ2	10 × 3/8	20



Welded Eye

Galvanised Fully Threaded

Product Codes Begin **9SEYEB** Product Group **5053**

EW925HDG2	10 × 3/8	20
EW930HDG2	12 × 3/8	20

BZP Part Threaded

EW615BZ	6 × 1/4	20	EW920BZ	8 × 3/8	20
EW820BZ	8 × 5/16	20	EW925BZ	10 × 3/8	20
EW915BZ	6 × 3/8	20	EW930BZ	12 × 3/8	20

Barrel Strainers



Galvanised

Fully Threaded

Product Codes Begin **9BSTRAIN** Product Group **5053**

4263162	M6	20
4263182	M8	20
4263202	M10	20

Easypost System

Brown Epoxy Coated on Zinc Plated Steel

Easypost Spike



Article No.	Size	Box Qty.
50/450S	50 × 50 × 450mm	6
75/600S	75 × 75 × 600mm	6
75/700S	75 × 75 × 700mm	6
100/700S	100 × 100 × 700mm	6

Product Codes Begin **9EASYPOST** Product Group **5056**



Easypost Repair Spike

75R	75 × 75mm	6
-----	-----------	---

Product Codes Begin **9EASYPOST** Product Group **5056**



Easypost Bolt-Down Support

50P	50 × 50mm	6
75P	75 × 75mm	6
100P	100 × 100mm	6

Product Codes Begin **9EASYPOST** Product Group **5056**



Easypost Concrete-In Support

Product Codes Begin **9EASYPOST** Product Group **5056**

75C	75 × 75mm	6
100C	100 × 100mm	6



Easypost Post Extender

Product Codes Begin **9EASYPOST** Product Group **5056**

1PE	3" × 3"	6
2PE	4" × 4"	6



Easypost U-Clip

Product Codes Begin **9EASYPOST** Product Group **5056**

44U	Small 44mm	100
52U	Large 51mm	100





A

Teco Galvanised Arris Rail Brackets



Product Codes Begin 9GAMAR Product Group 5052

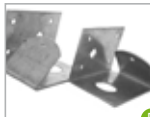

B

Article No.	Description	Box Qty.	
OJ087115	12" Galv Arris Rail Bracket	25	A
ARH	Handed Arris Rail Bracket (Pair)	25	B
ARM	Mortice Arris Rail Bracket	20	C



C

Teco Galvanised Gravel Board Clips



Product Codes Begin 9GRAVCLIP Product Group 5052



D

GBC	25mm x 125mm	50	D
GBC50	50mm x 175mm with Lip for Concrete	50	E



E

Teco Knee Rail Straps



Product Codes Begin 9KNEERAIL Product Group 5052



F

KR90B	250mm x 250mm x 90mm	50	F
-------	----------------------	----	---



G

Teco Post Shoes Heavy Duty Galvanised



Product Codes Begin 9POSTSHOE Product Group 5052

PSC	Cake Stand - 75mm Post or Above	1	G
-----	---------------------------------	---	---



Teco Joist Hangers

Galvanised Woody No Tag Timber-to-Timber Joist Hangers



Product Codes Begin **9JHWNT** Product Group **5060**

Article No.	Size	Box Qty.			
WNT 44	44mm	100	WNT 75	75mm	100
WNT 50	47mm	100	WNT 90	90mm	100
WNT 63	63mm	100	WNT 100	100mm	100



Galvanised Standard Woody Joist Hangers

Timber-to-timber with tag on base



Product Codes Begin **9JHWS** Product Group **5060**

WOODY STD 50	47mm × 275mm	100	WOODY STD 100	100mm × 300mm	50
WOODY STD 76	76mm × 300mm	50	WOODY STD 150	150mm × 300mm	50



Galvanised Long Leg Joist Hangers



Product Codes Begin **9JHWLL** Product Group **5060**

LL450X50	47 × 450mm	25	LL450X100	100 × 450mm	25
LL450X90	90 × 450mm	25			



Galvanised Mini Woody Joist Hangers



Product Codes Begin **9JHWM** Product Group **5060**

MINI 50	47mm × 94mm	25
---------	-------------	----



Galvanised Mini Mini Woody Joist Hangers



Product Codes Begin **9JHMINIMINI** Product Group **5060**

MINI MINI 50	47mm × 65mm	1
--------------	-------------	---



Galvanised Original Masonry Joist Hangers



Product Codes Begin **9JHGO** Product Group **5060**

Article No.	Size	Box Qty.					
WM 50X100	100 × 50mm	CE	45	WM 100X200	200 × 100mm	CE	15
WM 50X125	125 × 50mm	CE	40	WM 50X225	225 × 50mm	CE	30
WM 50X150	150 × 50mm	CE	40	WM 76X225	225 × 76mm	CE	20
WM 50X175	175 × 50mm	CE	30	WM 100X225	225 × 100mm	CE	15
WM 50X200	200 × 50mm	CE	30				



Galvanised FHM Single Piece Masonry Joist Hangers



Product Codes Begin **9JHFHM** Product Group **5060**

FHM 50X100	100 × 50mm	CE	30	FHM 50X175	175 × 50mm	CE	20
FHM 50X125	125 × 50mm	CE	30	FHM 50X200	200 × 50mm	CE	20
FHM 50X150	150 × 50mm	CE	20	FHM 50X225	225 × 50mm	CE	20



Galvanised Truss Clip



Product Codes Begin **9JHTC** Product Group **5060**

TCW50	47 mm	150
-------	-------	-----



Galvanised Herringbone Joist Struts



Product Codes Begin **9JSHBQ** Product Group **5060**

HB 400	400C	50
--------	------	----

Teco Galvanised Restraint Straps

Lateral – HD Heavy Duty Traditional



Product Codes Begin 9GALVSTRAP Product Group 5060



Article No.	Size	Box Qty.
OJ321367	HD800 × 26.5 × 4mm – 100mm Bend	10
OJ321374	HD1000 × 26.5 × 4mm – 100mm Bend	10
OJ321381	HD1200 × 26.5 × 4mm – 100mm Bend	10
OJ321343	HD1200 × 26.5 × 4mm – 150mm Bend	10
HD1500B100	HD1500 × 26.5 × 4mm – 100mm Bend	10
OJ027166	HD1600 × 26.5 × 4mm – 100mm Bend	10

Vertical – LD Light Duty Traditional



Product Codes Begin 9GALVSTRAP Product Group 5060



Article No.	Size	Box Qty.
LD300B100	LD300 × 27.5 × 2.4mm – 100mm Bend	100
OJ313317	LD600 × 27.5 × 2.4mm – 100mm Bend	20
OJ313324	LD800 × 27.5 × 2.4mm – 100mm Bend	20
OJ313331	LD1000 × 27.5 × 2.4mm – 100mm Bend	20
OJ313348	LD1200 × 27.5 × 2.4mm – 100mm Bend	20

Strap & Twist



Product Codes Begin 9GALVSTRAP Product Group 5060



Article No.	Size	Box Qty.
OJ313591	LD600 × 27.5 × 2.4mm – 150mm Twist	20
OJ499390	LD1000 × 27.5 × 2.4mm – 100mm Twist	20
OJ313553	LD1000 × 27.5 × 2.4mm – 150mm Twist	20
OJ030500	LD1200 × 27.5 × 2.4mm – 100mm Twist	20

Flat



Product Codes Begin 9GALVSTRAP Product Group 5060



Article No.	Size	Box Qty.
OJ321442	LD1000 × 27.5 × 2.4mm	20
OJ499413	HD1000 × 26.5 × 4mm	10
LD220F	LD220	100

Teco Galvanised Door Frame Cramps



Product Codes Begin 9DFC Product Group 5060



Article No.	Size	Box Qty.
OJ310125	6 × 1 × 1/8"	100
OJ310132	8 × 1 × 1/8"	100
OJ310149	10 × 1 × 1/8"	100



Teco Galvanised Scroll Hip Irons



Product Codes Begin **9SHI** Product Group **5060**

OJ055527	12 × 6 × 1	1
----------	------------	---



Teco Galvanised Angle Bracket



Product Codes Begin **9ANGLEBRKT** Product Group **5063**

ABLD	50 × 50 × 28mm	100	AB90	90 × 90 × 63mm	50
AB50	50 × 50 × 63mm	100	AB150/90	150 × 90 × 63mm	50
AB60	60 × 40 × 63mm	50	AB150/150	150 × 150 × 63mm	50



Teco Fixing Band



Product Codes Begin **9FIXINGBAND** Product Group **5063**

TECO FBG	20mm × 1mm – 10m Coil	1
----------	-----------------------	---



Teco Camplates



Product Codes Begin **9CAMPLATE** Product Group **5060**

TECO NP 41X152	41 × 152mm	50
TECO NP 85X175	85 × 175mm	100
TECO NP 103X152	103 × 152mm	50



Teco Wall Starter Kits



Product Codes Begin **9UNIWALL** Product Group **5060**

WSTV G.430 Wall Starter

Article No.	Material Information	Box Qty.
WSTV	Austenitic Stainless Steel; Non Magnetic, Higher Rust & Corrosive Resistance, Greater Strength	10

- Total height 2.40m
- Brick or block thickness 60-250mm
- Slide to adjust



VE4 ST Steel Type 4 Housing Ties



Product Codes Begin **9VE4TIE** Product Group **5060**

Article No.	size	Box Qty.
OJ210438	225mm C€	250

Expanded Metal

Steel Flattened

Product Codes Begin **6SF** Product Group **22**

Article No.	Reference	Size	Aperture LWM / SWM mm	Thickness mm	Strand Width / mm
OJ248127	2451F	8' x 4'	24.00/5.60	3.20/1.40	
OJ248110	2471F	8' x 4'	24.00/7.10	2.40/1.10	
OJ248059	33111F	8' x 4'	33.00/11.00	3.20/1.50	
OJ248035	39181F	8' x 4'	39.00/18.30	4.70/2.70	
OJ248028	43141F	8' x 4'	43.00/14.20	4.60/2.70	

Steel Raised

Product Codes Begin **6S** Product Group **22**

OJ248219	30121	8' x 4'	30.50/12.00	2.40/1.60	OJ248103	50232	8' x 4'	50.00/23.00	3.10/3.00
OJ246871	45131	8' x 4'	45.00/13.00	5.90/4.75	OJ248141	80241	8' x 4'	80.00/24.00	6.30/4.75

Aluminium Raised

Product Codes Begin **6AR** Product Group **22**

OJ248080	311A	2' x 25'	3.10/1.80	0.28/0.30
OJ248073	1051A	4' x 3'	10.20/5.60	1.50/0.90

Tile Guard and Brackets

Tile Guard

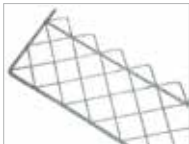

Product Codes Begin **9SNOWG** Product Group **5068**

Article No.	Material Information	Unit of Sale
OJ055824	2 Metre x 6"	1
OJ055831	2 Metre x 9"	1

• At least four brackets should be used per length of Tile Guard

Tile Guard Brackets



Product Codes Begin **9SNOWGB** Product Group **5068**

OJ055848	To Suit 6"	1
OJ055855	To Suit 9"	1



Pipe Caps

Grey Plastic Coated Wire



Product Codes Begin 9GREYPWPC Product Group 5069

Article No.	Size	Box Qty.						
OJ029870	2"	10	OJ029900	4"	5	OJ029931	9"	10
OJ029887	2.1/2"	10	OJ029917	6"	10			
OJ029894	3"	10	OJ029924	8"	10			

Chain Products Range

Merchandisers



• N100 Ready2Go



• N100 Ready2Reel



• N50 Ready2Reel

Chain Products Range

Chain



Pre-cut Lengths of Welded Chain on Hanging Cards – 5 Lengths per Box



Product Codes Begin 9TQCHAIN Product Group 5070

Article No.	Finish	Thickness	Link Length	Inside Length	Inside Width	Max Load	Length per Card
CC25BZP	BZP	2.5mm	24mm	5mm	30kg	2.5m	
CC30BZP	BZP	3mm	26mm	6mm	40kg	2.5m	
CC40BZP	BZP	4mm	32mm	8mm	80kg	3.0m	
CC50BZP	BZP	5mm	35mm	10mm	125kg	2.0m	
CC60BZP	BZP	6mm	42mm	12mm	160kg	2.0m	
CA70BZP	BZP	7mm	28mm	14mm	220kg	1.5m	



Black



BZP



HDG

Reels of Welded Chain DIN 5685

Product Codes Begin **9TQCHAIN** Product Group **5070**

Article No.	Finish	Thickness	Link Length	Inside Length	Inside Width	Max Load	Reel Length
TQA25BLK	Black	2.5mm	14mm	5mm	30kg	30m	
TQA30BLK	Black	3mm	16mm	6mm	40kg	30m	
TQA40BLK	Black	4mm	19mm	8mm	80kg	30m	
TQA50BLK	Black	5mm	21mm	10mm	125kg	30m	
TQA25BZP	BZP	2.5mm	14mm	5mm	30kg	30m	
TQC25BZP	BZP	2.5mm	24mm	5mm	30kg	30m	
TQA30BZP	BZP	3mm	16mm	6mm	40kg	30m	
TQB30BZP	BZP	3mm	21mm	8mm	40kg	30m	
TQA40BZP	BZP	4mm	19mm	8mm	80kg	30m	
TQC40BZP	BZP	4mm	32mm	8mm	80kg	30m	
TQC50BZP	BZP	5mm	35mm	10mm	125kg	30m	
TQB60BZP	BZP	6mm	33mm	13mm	160kg	20m	
TQC60BZP	BZP	6mm	42mm	12mm	160kg	20m	
TQA70BZP	BZP	7mm	28mm	14mm	220kg	15m	
TQA80BZP	BZP	8mm	32mm	16mm	320kg	15m	
TQB60HDG	HDG	6mm	33mm	13mm	160kg	20m	
TQC70HDG	HDG	7mm	49mm	14mm	220kg	15m	



Black



HDG

Cartons of Welded Chain – in 10 metre Cartons

Product Codes Begin **9TQCHAIN** Product Group **5070**

Article No.	Finish	Thickness	Link Length	Inside Length	Inside Width	Max Load
TQBA25BLK	Black	2.5mm	14mm	5mm	30kg	
TQBA40BLK	Black	4mm	19mm	8mm	80kg	
TQBC50BLK	Black	5mm	35mm	10mm	125kg	
TQBA25HDG	HDG	2.5mm	14mm	5mm	30kg	
TQBB30HDG	HDG	3mm	21mm	8mm	40kg	
TQBA40HDG	HDG	4mm	19mm	8mm	80kg	
TQBC40HDG	HDG	4mm	32mm	8mm	80kg	
TQBC50HDG	HDG	5mm	35mm	10mm	125kg	
TQBB60HDG	HDG	6mm	33mm	13mm	160kg	



Plastic Chain on Reels

Product Codes Begin **9TQCHAIN** Product Group **5070**

Article No.	Colour	Thickness	Link Length	Inside Length	Reel Length
TQPC06RWR	Red/White	6mm	50mm	30mtr	



Chain Products Range

Chain

Oval Link Chain on Reels



Product Codes Begin **9TQCHAIN** Product Group **5070**

Article No.	Finish	Link Size	Max Load	Reel Length					
TQAG017SBP	EB on Steel	1/2" x 15g	11kg	20m	TQAG020SBP	EB on Steel	5/8" x 13g	16kg	10m
TQAG017SCP	CP on Steel	1/2" x 15g	11kg	20m	TQAG020SCP	CP on Steel	5/8" x 13g	16kg	10m

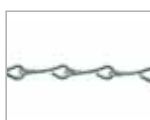

Single Jack Chain on Reels



Product Codes Begin **9TQCHAIN** Product Group **5070**

Article No.	Finish	Size	Max Load	Length
TQS20PG10	Pre Galvanised	2.0mm (No. 14)	3.5kg	10m

Rope

Polypropylene Rope on Reels – 3 Strand



Product Codes Begin **9TROPE** Product Group **5070**

Article No.	Colour	Size	Max Load	Length					
TQPP04BE	Blue	4mm	30kg	220m	TQPP10BE	Blue	10mm	180kg	55m
TQPP06BE	Blue	6mm	70kg	110m	TQPP12BE	Blue	12mm	260kg	35m
TQPP08BE	Blue	8mm	130kg	73m					



Polypropylene Rope in Mini Coils



Product Codes Begin **9ROPE** Product Group **5071**

BR630	Blue	6mm	180kg	30m	BR1030	Blue	10mm	70kg	30m
BR830	Blue	8mm	260kg	30m	BR1230	Blue	12mm	1300kg	30m



Sisal Rope on Reels – 3 Strand



Product Codes Begin **9TROPE** Product Group **5070**

Article No.	Colour	Size	Max Load	Length
TQSL08NL	Natural	8mm	60kg	73m
TQSL10NL	Natural	10mm	75kg	55m

Chain Products Range

Rope



Braided Polypropylene Rope on Reels

Product Codes Begin **9TQROPE** Product Group **5070**

Article No.	Colour	Size	Max Load	Length
TQMFB03WE	White	3mm	13kg	50m
TQMFB04WE	White	4mm	30kg	50m
TQMFB04BE	Blue	4mm	30kg	50m
TQMFB04GN	Green	4mm	30kg	50m



Wire Rope on Reels

Product Codes Begin **9TQROPE** Product Group **5070**

TQSW WR20ST	BZP	2mm	40kg	200m
TQSW WR30ST	BZP	3mm	90kg	200m
TQSW WR50ST	BZP	5mm	240kg	100m



Shock Cord Assemblies – Elastic Cord with Metal Hooks

Product Codes Begin **9TQROPE** Product Group **5070**

Article No.	Size	Length
HRT824	8mm	24"



Accessories



Quick Repair Links on Euro Slotted Header Cards

Product Codes Begin **9TQCHAIN** Product Group **5070**

Article No.	Finish	Card Qty. Size	Unit of Sale
CD03004	BZP	4mm 2	Box of 10
CD03006	BZP	6mm 2	Box of 10
CD03008	BZP	8mm 1	Box of 10



Dee Shackles on Euro Slotted Header Cards

Product Codes Begin **9TQCHAIN** Product Group **5070**

CD02005	BZP	5mm	2	Box of 10
CD02006	BZP	6mm	2	Box of 10
CD02008	BZP	8mm	1	Box of 10





Carbine Hooks on Euro Slotted Header Cards



Product Codes Begin **9TQCHAIN** Product Group **5070**

Article No.	Finish	Card Qty. Size	Unit of Sale
CD07040	BZP	4 × 40mm	2 Box of 10
CD07050	BZP	5 × 50mm	2 Box of 10
CD07060	BZP	6 × 60mm	2 Box of 10
CD07070	BZP	7 × 70mm	1 Box of 10



Wire Rope Grips on Euro Slotted Header Cards



Product Codes Begin **9TQCHAIN** Product Group **5070**

CD09003	Galvanised	3mm	4	Box of 10
CD09005	Galvanised	5mm	4	Box of 10



Swivel Spring Hook on Euro Slotted Header Cards



Product Codes Begin **9TQCHAIN** Product Group **5070**

CD04062	BZP	2.1/2"	2	Box of 10
CD04075	BZP	3"	1	Box of 10



S Hooks on Euro Slotted Header Cards



Product Codes Begin **9TQCHAIN** Product Group **5070**

CD01038	BZP	1.1/2"	3	Box of 10
CD01050	BZP	2"	3	Box of 10



Accessories

Ball Chain Fittings on Euro Slotted Header Cards



Product Codes Begin **9TQCHAIN** Product Group **5070**

Article No.	Finish	Card Qty. Size	Unit of Sale
CD08006	NP on Brass	No. 6	8 Box of 10



A

Sash Cord



Product Codes Begin **9SASHCORD** Product Group **5071**



B



C

Article No.	Finish	Card Qty. Size	Length
PJ03	Jute	No. 3 (5mm)	10m A
PJ04	Jute	No. 4 (6mm)	10m A
PWC03	Waxed Cotton	No. 3 (5mm)	10m B
PWC04	Waxed Cotton	No. 4 (6mm)	10m B
SBR08	Cotton Polished Red Spot	No. 8 (6mm)	10m C



Cable Clips and Ties

Cable Ties

Product Codes Begin **ZZV** Product Group **4009**

Article No.	Size	Colour	Box Qty.								
V59650	100×2.5	Black	100	V59660	370×7.6	Black	100	V59671	290×7.6	Natural	100
V59664	140×3.6	Black	100	V59672	450×9.0	Black	100	V59679	295×3.6	Natural	100
V59652	160×4.8	Black	100	V59674	550×9.0	Black	100	V59657	295×4.8	Natural	100
V59676	200×2.5	Black	100	V59680	780×9.0	Black	100	V59659	370×4.8	Natural	100
V59666	200×3.6	Black	100	V59651	100×2.5	Natural	100	V59661	370×7.6	Natural	100
V59654	200×4.8	Black	100	V59665	140×3.6	Natural	100	V59673	450×9.0	Natural	100
V59670	290×7.6	Black	100	V59653	160×4.8	Natural	100	V59675	550×9.0	Natural	100
V59678	295×3.6	Black	100	V59677	200×2.5	Natural	100	V59681	780×9.0	Natural	100
V59656	295×4.8	Black	100	V59667	200×3.6	Natural	100				
V59658	370×4.8	Black	100	V59655	200×4.8	Natural	100				



Adhesive Bases

Product Codes Begin **ZZV** Product Group **4009**

V59700	20×20	Black	100	V59701	20×20	Natural	100
V59702	28×28	Black	100	V59703	28×28	Natural	100



Cable Tie Wall Plug Box

Product Codes Begin **ZZV** Product Group **4009**

V54062	8mm	Black	1
--------	-----	-------	---



Cable Clips

Product Codes Begin **ZZV** Product Group **4009**

V42391	3.5mm	Black	1000	V44177	3.5mm	White	1000
V44150	4.5mm	Black	1000	V44178	4.5mm	White	1000
V44151	5.0mm	Black	1000	V44179	5.0mm	White	1000
V44152	6.0mm	Black	1000	V44180	6.0mm	White	1000
V44153	7.0mm	Black	1000	V44181	7.0mm	White	1000
V42393	9.0mm	Black	100	V42438	9.0mm	White	1000
V44154	11mm	Black	100	V44182	11.0mm	White	100
V44155	14mm	Black	100	V42439	14.0mm	White	100
V42429	4.5mm	Grey	1000	V42415	3.5mm	Brown	1000
V42430	5.0mm	Grey	1000	V44168	4.5mm	Brown	1000
V42431	6.0mm	Grey	1000	V44390	6.0mm	Brown	1000
V42432	9.0mm	Grey	100	V44169	7.0mm	Brown	1000
V44174	11mm	Grey	100	V42418	7.0mm	Red	1000
V44175	14mm	Grey	100	V42419	9.0mm	Red	100



Flat Clips

Product Codes Begin ZZV Product Group 4009

Article No.	Size	Colour	Box Qty.
V44166	2.5mm	Black	1000
V44186	4.0mm	Black	100
V44187	6.0mm	Black	100
V42413	4.0mm	Brown	100
V44167	6.0mm	Brown	100
V44161	1.0mm	Grey	1000
V44162	1.5mm	Grey	1000
V44163	2.5mm	Grey	1000
V42412	4.0mm	Grey	100

V44164	6.0mm	Grey	100
V44165	10mm	Grey	100
V44158	1.0mm	White	1000
V42404	1.5mm	White	1000
V44159	2.5mm	White	1000
V42407	4.0mm	White	100
V44160	6.0mm	White	100
V42408	10mm	White	100



Masonry Nail Pipe Clips

Product Codes Begin ZZV Product Group 4009

V44156	16mm	Black	100
V42394	19mm	Black	100
V44157	22mm	Black	100
V44176	16mm	Grey	100
V44261	19mm	Grey	100
V44262	22mm	Grey	100

V54140	16mm	Cream	100
V44183	16mm	White	100
V42441	19mm	White	100
V44184	22mm	White	100
V44185	28mm	White	50



Kliplock Single™

Product Codes Begin ZZ5 Product Group 4009

511331	15mm	White	100
511333	22mm	White	100
511363	28mm	White	100

511332	15mm	White	50
511334	22mm	White	50
511364	28mm	White	50



Kliplock Double™

Product Codes Begin ZZ5 Product Group 4009

511332	15mm	White	50
511334	22mm	White	50
511364	28mm	White	50



Openlok Single™

Product Codes Begin ZZV Product Group 4009

V43613	15mm	White	100
V43614	22mm	White	100



Openlok Double™

V43616	15mm	White	50
--------	------	-------	----

Product Codes Begin ZZV Product Group 4009



Single Open Click, Rectangular Bottom

V43615	28mm	White	100
--------	------	-------	-----

Product Codes Begin ZZV Product Group 4009



Hinged and Snap-In Open Pipe Clips

Product Codes Begin ZZV Product Group 4009

Article No.	Type	Size	Colour	Box Qty.
V53547	Single Hinge	15mm	White	100
V53548	Single Hinge	22mm	White	100
V53545	Double Hinge	15mm	White	50
V53546	Double Hinge	22mm	White	50
V53549	Single Snap In	15mm	White	100
V53551	Double Snap In	15mm	White	50
V53552	Double Snap In	22mm	White	50



Pipe Clip Reducer

Product Codes Begin ZZ5 Product Group 4009

Article No.	Size	Colour	Box Qty.
511365	22-15mm	White	100



Pipe Spacer Block

Product Codes Begin ZZ5 Product Group 4009

Article No.	Size	Colour	Box Qty.
511366	15mm	White	100
511367	22mm	White	100



Pipe Covers

Product Codes Begin ZZV Product Group 4009

Article No.	Size	Colour	Box Qty.
V42139	10mm	White	25
V42140	15mm	White	25
V42141	22mm	White	25
V42142	28mm	White	25
V42144	15mm	Silver	25
V42145	22mm	Silver	25



Ace Hose Clips & Accessories

BZP Hose Clips



Band, housing & screw: zinc plated mild steel BS5315



Product Codes Begin **ACEHCZ** Product Group **5089**

Article No.	Size (mm)	Box Qty.							
000 ACE1806	9.5-12	10	1X ACE1813	30-40	10	4 ACE1820	70-90	10	
M00 ACE1807	11-16	10	1M ACE1814	32-45	10	4X ACE1821	85-100	10	
00 ACE1808	13-20	10	2A ACE1815	35-50	10	5 ACE1822	90-120	10	
0 ACE1809	16-22	10	2 ACE1816	40-55	10	6 ACE1823	110-140	10	
0X ACE1810	18-25	10	2X ACE1817	45-60	10	7 ACE1824	135-160	10	
1A ACE1811	22-30	10	3 ACE1818	55-70	10				
1 ACE1812	25-35	10	3X ACE1819	60-80	10				

BZP Cut To Length Hose Clips



9mm band. Measuring guide included. Zinc Plated (W2).



Product Codes Begin **ACEHCR** Product Group **5089**

Article No.	Description	Box Qty.
ACE2314	30m Roll & Cut BZP - c/w 30 Heads	1

Stainless Steel Hose Clips



Stainless Steel (W4) BS5315



Product Codes Begin **ACEHCSS**

Article No.	Size (mm)	Box Qty.							
000 ACE4505	9.5-12	10	1X ACE4512	30-40	10	4 ACE4521	70-90	10	
M00 ACE4506	11-16	10	1M ACE4513	32-45	10	4X ACE4522	85-100	10	
00 ACE4507	13-20	10	2A ACE4514	35-50	10	5 ACE4523	90-120	10	
0 ACE4508	16-22	10	2 ACE4515	40-55	10	6 ACE4524	110-140	10	
0X ACE4509	18-25	10	2X ACE4516	45-60	10	7 ACE4525	135-160	10	
1A ACE4510	22-30	10	3 ACE4517	55-70	10				
1 ACE4511	25-35	10	3X ACE4520	60-80	10				

Hose Clip Accessories



Product Codes Begin **ACEHC**

Article No.	Description
ACE6020	7mm Nut Driver

BZP T Bolt Clamps – W1

Rolled edges band and flange. Band, screw, cylinders, flange: zinc plated mild steel.



Product Codes Begin **ACEHCSS**



Article No.	Size (mm)	Box Qty.						
ACE1021	20-22	10	ACE1176	40-43	10	ACE1182	64-67	10
ACE1171	23-25	10	ACE1177	44-47	10	ACE1183	68-73	10
ACE1172	26-28	10	ACE1178	48-51	10	ACE1184	74-79	10
ACE1173	29-31	10	ACE1179	52-55	10			
ACE1174	32-35	10	ACE1180	56-59	10			
ACE1175	36-39	10	ACE1181	60-63	10			

Stainless Steel T Bolt Clamps – W1

Rolled edges and flange. Band, screw, cylinders, flange.



Product Codes Begin **ACETBSS**



ACE4045	40-43	5	ACE4051	64-67	5
ACE4046	44-47	5	ACE4052	68-73	5
ACE4047	48-51	5			
ACE4048	52-55	5			
ACE4049	56-59	5			
ACE4050	60-63	5			

Hose Clip Display Stands



Product Codes Begin **ACE**

Article No.	Description	
ACE4519	Stainless Steel Hose Clip Dispenser	A
ACE1830	BZP Hose Clip Dispenser	B
ACE1309	BZP T Bolt Dispenser	C



A



B



C



Jubilee Hose Clips



Product Codes Begin **9JUBILEE**



Article No.	Size (mm)	Box Qty.						
M00	11-16	10	1A	22-30	10	3X	60-80	1
000	9.5-12	10	1X	27-40	10	4	70-90	1
00	13-20	10	2A	35-50	10	5	90-120	1
0	16-22	10	2	40-55	10	6	110-140	1
0X	18-25	10	2X	45-60	10	7	135-165	1
1	25-35	10	3	55-70	10			

Manufacturing Features

- Jubilee® clips are Kite marked to BS 5315 : 1991
- Manufactured under the stringent BS EN ISO 9001:2008 accreditation processes
- Jubilee Clips are manufactured with a built-in abuse factor to exceed British Standard breaking torque figures
- Manufactured to perform in excess of British Standard minimum requirements
- Stainless Steel range is Lloyd's Type Approved
- Rigorous quality control processes (from raw material to finished product) not only within BS 5315 but also for individual customer requirements, including testing to find out how the clips stand up to vibration, pressure and torque as well as salt spray testing to measure corrosion resistance.

Product features

- Continuously press threaded enabling flexibility of size choices
- Smooth inner band to prevent hose damage and positive contact
- Superior crimping to retain and support the screw in the housing
- 14 TPI screw and thread form allows for even and consistent tightening
- Five sizes of housing to ensure efficient thread contact and accurate form
- 7mm A/F hexagon screw with screwdriver slot
- Positively riveted housing and housing design ensures free turning torque compatible with maximum strength



BS3621 5 Lever Mortice Locks



ASSA ABLOY



A

Article No.	Prod. Code	Description	Size	Finish	Prod. Group		
J 2234E SC 67	9MORTL/320	BS3621 5 Lever Sashlock	67mm	SC	5074	<input checked="" type="checkbox"/>	A
DY2234E PL 2.5"	9DYMORTL/260	BS3621 5 Lever Sashlock	67mm	PL	5074	<input type="checkbox"/>	
DY2234E PL 3.0"	9DYMORTL/265	BS3621 5 Lever Sashlock	80mm	PL	5074	<input type="checkbox"/>	
DY2234E SC 2.5"	9DYMORTL/270	BS3621 5 Lever Sashlock	67mm	SC	5074	<input type="checkbox"/>	
DY2234E SC 3.0"	9DYMORTL/275	BS3621 5 Lever Sashlock	80mm	SC	5074	<input type="checkbox"/>	

- Deadbolt locked or unlocked by key from either side • Latch bolt withdrawn by lever handle from either side
- Extended 20mm deadbolt for secure positive deadlocking and additional resistance against attack • 2234E may be keyed alike with 2134E



B

V/3K74E/PB/67	9CHUM3K74E/005	BS3621 5 Lever Sashlock	67mm	PB	5074	<input type="checkbox"/>	B
V/3K74E/SC/67	9CHUM3K74E/015	BS3621 5 Lever Sashlock	67mm	SC	5074	<input type="checkbox"/>	

- Deadbolt is locked or unlocked by key from either side • Extended 20mm deadbolt for secure positive deadlocking and resistance against attack
- Latch bolt withdrawn by lever handle from either side • Force resistant, anti drill, anti-pick and anti-saw security features



C

DY2134E PL 2.5"	9DYMORTL/240	BS3621 5 Lever Deadlock	67mm	PL	5074	<input type="checkbox"/>	C
DY2134E PL 3.0"	9DYMORTL/245	BS3621 5 Lever Deadlock	80mm	PL	5074	<input type="checkbox"/>	
DY2134E SC 2.5"	9DYMORTL/250	BS3621 5 Lever Deadlock	67mm	SC	5074	<input type="checkbox"/>	
DY2134E SC 3.0"	9DYMORTL/255	BS3621 5 Lever Deadlock	80mm	SC	5074	<input type="checkbox"/>	

- Deadbolt locked or unlocked by the key from either side • 20mm deadbolt for secure positive deadlocking and additional resistance against attack
- 2100S can be keyed alike with 2200S • Anti-pick, anti-saw and anti-drill security features for resistance against attack



D

B/3G114E/PB/67	9CHUM3G114E/025	BS3621 5 Lever Deadlock	67mm	PB	5074	<input checked="" type="checkbox"/>	D
B/3G114E/SC/67	9CHUM3G114E/035	BS3621 5 Lever Deadlock	67mm	SC	5074	<input checked="" type="checkbox"/>	
V/3G114E/PB/67	9CHUM3G114E/005	BS3621 5 Lever Deadlock	67mm	PB	5074	<input type="checkbox"/>	
V/3G114E/SC/67	9CHUM3G114E/015	BS3621 5 Lever Deadlock	67mm	SC	5074	<input type="checkbox"/>	
V/3G114E/SC/80	9CHUM3G114E/020	BS3621 5 Lever Deadlock	80mm	SC	5074	<input type="checkbox"/>	

- Force resistant, anti drill, anti-pick and anti-saw security features • Available with square forend and striking plate • 20mm bolt throw
- Can be supplied on patented RKS key section to prevent illicit copying of keys

BS3621 5 Lever Mortice Locks



Article No.	Prod. Code	Description	Size	Finish	Prod. Group		
HQ2470/2	9HQMORT/2470	BS3621 5 Lever Sashlock	65mm	SS	5001	<input type="checkbox"/>	
HQ2471/2	9HQMORT/2471	BS3621 5 Lever Sashlock	65mm	EB	5001	<input type="checkbox"/>	
HQ2475/2	9HQMORT/2475	BS3621 5 Lever Sashlock	75mm	SS	5001	<input type="checkbox"/>	
HQ2476/2	9HQMORT/2476	BS3621 5 Lever Sashlock	75mm	EB	5001	<input type="checkbox"/>	
HQ2480/2	9HQMORT/2480	BS3621 5 Lever Sashlock	65mm	SS	5001	<input type="checkbox"/>	
HQ2481/2	9HQMORT/2481	BS3621 5 Lever Sashlock	65mm	EB	5001	<input type="checkbox"/>	
HQ2485/2	9HQMORT/2485	BS3621 5 Lever Sashlock	75mm	SS	5001	<input type="checkbox"/>	
HQ2486/2	9HQMORT/2486	BS3621 5 Lever Sashlock	75mm	EB	5001	<input type="checkbox"/>	



5 Lever Mortice Locks



ASSA ABLOY



A



B



C



D

Article No.	Prod. Code	Description	Size	Finish	Prod. Group		
DY2201 PL 2.5"	9DYMORTL/080	5 Lever Sashlock	65mm	PB	5074	<input type="checkbox"/>	A
DY2201 PL 3.0"	9DYMORTL/090	5 Lever Sashlock	77mm	PB	5074	<input type="checkbox"/>	
DY2201 SC 2.5"	9DYMORTL/075	5 Lever Sashlock	65mm	SC	5074	<input type="checkbox"/>	
DY2201 SC 3.0"	9DYMORTL/085	5 Lever Sashlock	77mm	SC	5074	<input type="checkbox"/>	

- Deadbolt locked or unlocked by key from either side • Latch bolt withdrawn by lever handle from either side
- May be keyed alike with 2101 and 2401 • Pierced to accept bolt through furniture

3K75CLAMPA PB	9CHUM3K75/005	5 Lever Economy Sashlock	67mm	PB	5074	<input type="checkbox"/>	B
---------------	---------------	--------------------------	------	----	------	--------------------------	---

DY2101 PL 2.5"	9DYMORTL/060	5 Lever Deadlock	65mm	PB	5074	<input type="checkbox"/>	C
DY2101 PL 3.0"	9DYMORTL/070	5 Lever Deadlock	77mm	PB	5074	<input type="checkbox"/>	
DY2101 SC 2.5"	9DYMORTL/055	5 Lever Deadlock	65mm	SC	5074	<input type="checkbox"/>	
DY2101 SC 3.0"	9DYMORTL/065	5 Lever Deadlock	77mm	SC	5074	<input type="checkbox"/>	

- Deadbolt locked or unlocked by key from either side • May be keyed alike with 2201 & 2401
- NB: Not suitable for master keying • Security box striking plate

3G115 PL	9CHUM3G115/010	5 Lever Mortice Deadlock	67mm	PB	5074	<input type="checkbox"/>	D
3G115 SC	9CHUM3G115/005	5 Lever Mortice Deadlock	67mm	SC	5074	<input type="checkbox"/>	

- Deadbolt is locked or unlocked by key from either side • Force resistant, anti-pick and anti-saw security features
- Available with square forend and striking plate • 14mm bolt throw

5 Detainer Mortice Locks



ASSA ABLOY



A



B

Article No.	Prod. Code	Description	Size	Finish	Prod. Group		
3G110/106	9CHUM3G110/005	5 Detainer Deadlock	73mm	SC	5074	<input type="checkbox"/>	A
3G110/109	9CHUM3G110/010	5 Detainer Deadlock	73mm	PB	5074	<input type="checkbox"/>	B

- Deadbolt is locked or unlocked by key from either side
- Force resistant, anti-drill, anti-pick and anti-saw security features • 14mm bolt throw

3K70/218	9CHUM3K70/020	5 Detainer Upright Lock RH	73mm	PB	5074	<input type="checkbox"/>	B
----------	---------------	----------------------------	------	----	------	--------------------------	---

- Deadbolt is locked or unlocked by key from either side • Latch bolt withdrawn by lever handle from either side
- Force resistant, anti-pick and anti-saw security features



3 Lever Mortice Locks



Article No.	Prod. Code	Description	Size	Finish	Prod. Group		
PM320PB 2.5"	9YABMLPM320/051	3 Lever Sashlock	65mm	PB	5098	<input type="checkbox"/>	<input checked="" type="checkbox"/> A



3 Lever Mortice Locks



HQ2400/2	9HQMORT/2400	3 Lever Sashlock	65mm	NP/EB	5001	<input type="checkbox"/>	
HQ2405/2	9HQMORT/2405	3 Lever Sashlock	75mm	NP/EB	5001	<input type="checkbox"/>	<input checked="" type="checkbox"/> A
HQ2410/2	9HQMORT/2410	3 Lever Deadlock	65mm	NP/EB	5001	<input type="checkbox"/>	
HQ2415/2	9HQMORT/2415	3 Lever Deadlock	75mm	NP/EB	5001	<input type="checkbox"/>	

• Easy reversible latch bolt • 100 differs



3 Lever Mortice Locks

KX1030	9KXMORT/1030	3 Lever Sashlock	50mm	NP	5000	<input checked="" type="checkbox"/>	<input checked="" type="checkbox"/> A
KX1035	9KXMORT/1035	3 Lever Sashlock	65mm	NP/EB	5000	<input checked="" type="checkbox"/>	
KX1040	9KXMORT/1040	3 Lever Sashlock	75mm	NP/EB	5000	<input checked="" type="checkbox"/>	
KX1045	9KXMORT/1045	3 Lever Deadlock	65mm	NP/EB	5001	<input checked="" type="checkbox"/>	
KX1050	9KXMORT/1050	3 Lever Deadlock	75mm	NP/EB	5001	<input checked="" type="checkbox"/>	



3 Lever Mortice Locks



2277 PL 2.5"	9MORTL/041	3 Lever Sashlock	65mm	PL	5074	<input checked="" type="checkbox"/>	<input checked="" type="checkbox"/> A
2277 SC 2.5"	9MORTL/035	3 Lever Sashlock	65mm	SC	5074	<input checked="" type="checkbox"/>	
2277 SC 3.0"	9MORTL/040	3 Lever Sashlock	77mm	SC	5074	<input checked="" type="checkbox"/>	
DY2277 PL 2.5"	9DYMORTL/016	3 Lever Sashlock	65mm	PL	5074	<input type="checkbox"/>	
DY2277 PL 3.0"	9DYMORTL/021	3 Lever Sashlock	77mm	PL	5074	<input type="checkbox"/>	
DY2277 SC 2.5"	9DYMORTL/015	3 Lever Sashlock	65mm	SC	5074	<input type="checkbox"/>	
DY2277 SC 3.0"	9DYMORTL/020	3 Lever Sashlock	77mm	SC	5074	<input type="checkbox"/>	

• Deadbolt locked or unlocked by key from either side • Latch bolt withdrawn by lever handle from either side
 • May be keyed alike with 2077, 2157, 2177 and 2477 (not 51mm case) • Pierced to accept bolt through furniture



DY2177 PL 2.5"	9DYMORTL/006	3 Lever Deadlock	65mm	PL	5074	<input type="checkbox"/>	<input checked="" type="checkbox"/> B
DY2177 PL 3.0"	9DYMORTL/011	3 Lever Deadlock	77mm	PL	5074	<input type="checkbox"/>	
DY2177 SC 2.5"	9DYMORTL/005	3 Lever Deadlock	65mm	SC	5074	<input type="checkbox"/>	
DY2177 SC 3.0"	9DYMORTL/010	3 Lever Deadlock	77mm	SC	5074	<input type="checkbox"/>	

• Deadbolt locked or unlocked by key from either side • May be keyed alike with 2077, 2157, 2277 and 2477
 • NB: Not suitable for master keying • Available with square forend and striking plate



2077 PL 5.0"	9MORTL/011	3 Lever Horizontal Lock	124mm	PL	5074	<input checked="" type="checkbox"/>	<input checked="" type="checkbox"/> C
2077 PL 6.0"	9MORTL/012	3 Lever Horizontal Lock	149mm	PL	5074	<input checked="" type="checkbox"/>	
2077 SC 5.0"	9MORTL/013	3 Lever Horizontal Lock	124mm	SC	5074	<input checked="" type="checkbox"/>	
2077 SC 6.0"	9MORTL/010	3 Lever Horizontal Lock	149mm	SC	5074	<input checked="" type="checkbox"/>	
2477 SC 3.0"	9MORTL/060	3 Lever Sliding Door Lock	77mm	SC	5074	<input checked="" type="checkbox"/>	<input checked="" type="checkbox"/> D

• Expanding claw deadbolt • Claw deadbolt locked or unlocked by key from either side • May be keyed alike with 2077, 2157, 2177 and 2277



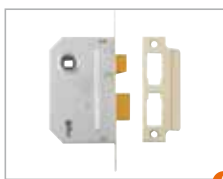

2 Lever Mortice Locks



Article No.	Prod. Code	Description	Size	Finish	Prod. Group		
PM246CP 2.5"	9YABMLPM246/005	2 Lever Sashlock	63mm	CH	5098	<input type="checkbox"/>	<input checked="" type="checkbox"/>

• 2 Lever Security • Standard Security level • 2 Year Guarantee



2 Lever Mortice Locks



2295 CH 2.5"	9MORTL/045	2 Lever Sashlock	63mm	CH	5074	<input checked="" type="checkbox"/>	<input checked="" type="checkbox"/>	<input checked="" type="checkbox"/>
2295 PL 2.5"	9MORTL/051	2 Lever Sashlock	63mm	PB	5074	<input checked="" type="checkbox"/>	<input type="checkbox"/>	<input type="checkbox"/>
DY2295 CH 2.5"	9DYMORTL/025	2 Lever Sashlock	63mm	CH	5074	<input type="checkbox"/>	<input type="checkbox"/>	<input type="checkbox"/>
DY2295 CH 3.0"	9DYMORTL/030	2 Lever Sashlock	76mm	CH	5074	<input type="checkbox"/>	<input type="checkbox"/>	<input type="checkbox"/>
DY2295 PL 2.5"	9DYMORTL/026	2 Lever Sashlock	63mm	PB	5074	<input type="checkbox"/>	<input type="checkbox"/>	<input type="checkbox"/>
DY2295 PL 3.0"	9DYMORTL/031	2 Lever Sashlock	76mm	PB	5074	<input type="checkbox"/>	<input type="checkbox"/>	<input type="checkbox"/>

• Deadbolt locked or unlocked by key from either side • Latch bolt withdrawn by lever handle from either side
• Reversible latch bolt • May be keyed alike with 2242



2 Lever Rebated Mortice Locks



2242 SC 2.5"	9MORTL/025	2 Lever Rebated Sashlock	65mm	SE	5074	<input checked="" type="checkbox"/>	<input checked="" type="checkbox"/>	<input checked="" type="checkbox"/>
2242 EB 2.5"	9MORTL/031	2 Lever Rebated Sashlock	65mm	EB	5074	<input checked="" type="checkbox"/>	<input type="checkbox"/>	<input type="checkbox"/>
DY2242 EB 2.5"	9DYMORTL/014	2 Lever Rebated Sashlock	66mm	EB	5074	<input type="checkbox"/>	<input type="checkbox"/>	<input type="checkbox"/>
DY2242 SE 2.5"	9DYMORTL/013	2 Lever Rebated Sashlock	66mm	SE	5074	<input type="checkbox"/>	<input type="checkbox"/>	<input type="checkbox"/>

• Deadbolt locked or unlocked by key from either side • Latch bolt withdrawn by lever handle from either side • Suitable for 12.5mm full rebated timber doors



Bathroom Mortice Lock



Article No.	Prod. Code	Description	Size	Finish	Prod. Group		
2294 CH 2.5"	9MORTL/055	Bathroom Lock	63mm	CH	5074	<input checked="" type="checkbox"/>	<input checked="" type="checkbox"/> A
DY2294 CH 2.5"	9DYMORTL/045	Bathroom Lock	63mm	CH	5074	<input type="checkbox"/>	
DY2294 CH 3.0"	9DYMORTL/050	Bathroom Lock	76mm	CH	5074	<input type="checkbox"/>	
DY2294 PL 2.5"	9DYMORTL/046	Bathroom Lock	63mm	PB	5074	<input type="checkbox"/>	
DY2294 PL 3.0"	9DYMORTL/051	Bathroom Lock	76mm	PB	5074	<input type="checkbox"/>	

- Deadbolt locked or unlocked by separate turn from inside • Deadbolt unlocked by separate emergency release from outside
- Latch bolt withdrawn by lever handle from either side • Reversible latch bolt



Bathroom Mortice Lock



Article No.	Prod. Code	Description	Size	Finish	Prod. Group		
HQ2450/2	9HQMORTL/2450	Bathroom Lock	65mm	SSS/PSS	5001	<input type="checkbox"/>	
HQ2455/2	9HQMORTL/2455	Bathroom Lock	75mm	SSS/PSS	5001	<input type="checkbox"/>	

- Deadbolt locked or unlocked by separate turn from inside • Deadbolt unlocked by separate emergency release from outside
- Latch bolt withdrawn by lever handle from either side • Reversible latch bolt



Bathroom Mortice Lock

KX1055	9KXMORT/1055	Bathroom Lock	65mm	SSS/PSS	5000	<input checked="" type="checkbox"/>	
KX1060	9KXMORT/1060	Bathroom Lock	75mm	SSS/PSS	5000	<input checked="" type="checkbox"/>	

- Deadbolt locked or unlocked by separate turn from inside • Deadbolt unlocked by separate emergency release from outside
- Latch bolt withdrawn by lever handle from either side • Reversible latch bolt



Tubular Mortice Latch



Article No.	Prod. Code	Description	Size	Finish	Prod. Group		
PM888BRASS 2.5"	9YABMLPM888/025	Tubular Mortice Latch	64mm	PB	5098	<input type="checkbox"/>	A
PM888BRASS 3.0"	9YABMLPM888/030	Tubular Mortice Latch	76mm	PB	5098	<input type="checkbox"/>	

• Standard Security level • 2 Year Guarantee

Tubular Mortice Latch



ASSA ABLOY

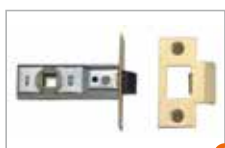

2648 EB 2.5"	9MORTL/077	Tubular Mortice Latch	64mm	PB	5074	<input checked="" type="checkbox"/>	A
2648 EB 3.5"	9MORTL/084	Tubular Mortice Latch	91mm	PB	5074	<input checked="" type="checkbox"/>	
2648 SC 2.5"	9MORTL/075	Tubular Mortice Latch	64mm	SC	5074	<input checked="" type="checkbox"/>	
2648 SC 3.0"	9MORTL/080	Tubular Mortice Latch	80mm	SC	5074	<input checked="" type="checkbox"/>	
DY2648 PL 2.5"	9DYMORTL/037	Tubular Mortice Latch	65mm	PB	5074	<input type="checkbox"/>	
DY2648 PL 3.0"	9DYMORTL/043	Tubular Mortice Latch	80mm	PB	5074	<input type="checkbox"/>	
DY2648 SE 2.5"	9DYMORTL/035	Tubular Mortice Latch	65mm	SC	5074	<input type="checkbox"/>	
DY2648 SE 3.0"	9DYMORTL/040	Tubular Mortice Latch	80mm	SC	5074	<input type="checkbox"/>	

• Latch bolt withdrawn by sprung lever handle from either side • Two way action • 2650 • rebated mortice latch (suitable for 13mm rebate)
• Available with square forend and striking plate • Case Size: 64.5mm (2.5"), 80mm (3") or 91.5mm (3.5")

Tubular Mortice Latch



HQ2231/4	9HTUBULAR/2231	Tubular Mortice Latch	€€	65mm	SNP	5001	<input type="checkbox"/>	A
HQ2233/4	9HTUBULAR/2233	Tubular Mortice Latch	€€	65mm	SNP	5001	<input type="checkbox"/>	
HQ2235/4	9HTUBULAR/2235	Tubular Mortice Latch	€€	75mm	SNP	5001	<input type="checkbox"/>	
HQ2239/4	9HTUBULAR/2239	Tubular Mortice Latch		65mm	NP	5001	<input type="checkbox"/>	
HQ2241/4	9HTUBULAR/2241	Tubular Mortice Latch		75mm	NP	5001	<input type="checkbox"/>	
HQ2243/4	9HTUBULAR/2243	Tubular Mortice Latch		65mm	EB	5001	<input type="checkbox"/>	
HQ2245/4	9HTUBULAR/2245	Tubular Mortice Latch		75mm	EB	5001	<input type="checkbox"/>	

Tubular Mortice Latch



KX1000	9KXMORT/1000	Tubular Latch Bolt		65mm	NP	5000	<input checked="" type="checkbox"/>	A
KX1005	9KXMORT/1005	Tubular Latch Bolt		75mm	NP	5000	<input checked="" type="checkbox"/>	
KX1010	9KXMORT/1010	Tubular Latch Bolt		65mm	EB	5000	<input checked="" type="checkbox"/>	
KX1015	9KXMORT/1015	Tubular Latch Bolt		75mm	EB	5000	<input checked="" type="checkbox"/>	
KX1020	9KXMORT/1020	Tubular Mortice Latch	€€	65mm	SNP	5000	<input checked="" type="checkbox"/>	
KX1025	9KXMORT/1025	Tubular Mortice Latch	€€	75mm	SNP	5000	<input checked="" type="checkbox"/>	



Fastlatch Latch/Bolt



JFL26-CH-2.5	9MORTL/130	Fastlatch Latch	60mm	PC	5074	■	
JFL26-SN-2.5	9MORTL/135	Fastlatch Latch	60mm	SN	5074	■	
JFL26-PB-2.5	9MORTL/140	Fastlatch Latch	60mm	PB	5074	■	
JFL26-CH-3.0	9MORTL/145	Fastlatch Latch	79mm	PC	5074	■	
JFL26-SN-3.0	9MORTL/150	Fastlatch Latch	79mm	SN	5074	■	
JFL26-PB-3.0	9MORTL/155	Fastlatch Latch	79mm	PB	5074	■	
JFL27-CH-2.5	9MORTL/160	Fastlatch Bolt	60mm	PC	5074	■	
JFL27-SN-2.5	9MORTL/165	Fastlatch Bolt	60mm	SN	5074	■	
JFL27-PB-2.5	9MORTL/170	Fastlatch Bolt	60mm	PB	5074	■	
JFL27-CH-3.0	9MORTL/175	Fastlatch Bolt	73mm	PC	5074	■	
JFL27-SN-3.0	9MORTL/180	Fastlatch Bolt	73mm	SN	5074	■	
JFL27-PB-3.0	9MORTL/185	Fastlatch Bolt	73mm	PB	5074	■	



Rebated Tubular Mortice Latch



ASSA ABLOY

Article No.	Prod. Code	Description	Size	Finish	Prod. Group		
DY2650 EB 2.5"	9DYMORTL/033	Rebated Tubular Latch	64mm	EB	5074		

- Latch bolt withdrawn by sprung lever handle from either side • Two way action • 2650 • Rebated mortice latch (suitable for 13mm rebate)
- Available with square forend and striking plate • Case Size: 64.5mm (2.5"), 80mm (3") or 91.5mm (3.5")



Standard Mortice Latch



ASSA ABLOY

2642 PL 3.0"	9MORTL/071	Mortice Latch	76mm	PB	5074		
2642 SC 2.5"	9MORTL/065	Mortice Latch	63mm	CH	5074		

- Latch bolt withdrawn by knob or sprung lever handles • Two way action • Available with square forend and locking plate
- Case Size: 63.5mm (2.5"), 76.5mm (3") or 101.5mm (4")



Oval Cylinder Mortice Lock Cases



ASSA ABLOY

L2241 SCP 3.0"	9MORTCYL/010	Oval Mortice Sashlock Case	77mm	SC	5074		
----------------	--------------	----------------------------	------	----	------	--	--

- Modular case range • Deadbolt is locked or unlocked by oval cylinder • Latch bolt withdrawn by lever handle • Pierced to accept bolt through furniture



Euro Cylinder Mortice Lock Cases

Article No.	Prod. Code	Description	Finish	Prod. Group		
KX1065	KXMORT/1065	Euro Profile Sashlock 47.6mm Centres	CE	SSS/PSS	5000	
KX1070	KXMORT/1070	Euro Profile Sashlock 47.6mm Centres	CE	SSS/PSS	5000	
KX1075	KXMORT/1075	Euro Profile Deadlock 47.6mm Centres	CE	SSS/PSS	5000	
KX1080	KXMORT/1080	Euro Profile Deadlock 47.6mm Centres	CE	SSS/PSS	5000	

Euro Profile Cylinders



Article No.	Prod. Code	Description	Size	Finish	Prod. Group		
PKM3535 NP	9YABCYLKM3535/005	Double Euro Profile	35 × 35 (80mm)	NP	5098	<input type="checkbox"/>	
PKM3545 NP	9YABCYLKM3545/005	Double Euro Profile	35 × 45 (90mm)	NP	5098	<input type="checkbox"/>	A
PKM4045 NP	9YABCYLKM4045/005	Double Euro Profile	40 × 45 (95mm)	NP	5098	<input type="checkbox"/>	
PKM4050 NP	9YABCYLKM4050/005	Double Euro Profile	40 × 50 (100mm)	NP	5098	<input type="checkbox"/>	
PKM4545 NP	9YABCYLKM4545/005	Double Euro Profile	45 × 45 (100mm)	NP	5098	<input type="checkbox"/>	

- Replacement 6 pin Euro Profile Cylinder • Available in Euro Single, Euro Double and Euro Turn • BSI Kitemark Approved – KM532920
- TS007 1 Star Cylinder • Secured by Design approved • High Security level • 10 Year Guarantee

Euro Profile Cylinders



Article No.	Prod. Code	Description	Size	Finish	Prod. Group		
HQ2300/4	9HQCYL/2300	Key Blank Euro & Rim Bag (3)			5001	<input type="checkbox"/>	
HQ2305/2	9HQCYL/2305	Double Euro Profile	30 × 30	NP	5001	<input type="checkbox"/>	B
HQ2310/2	9HQCYL/2310	Double Euro Profile	35 × 35	NP	5001	<input type="checkbox"/>	
HQ2315/2	9HQCYL/2315	Double Euro Profile	40 × 40	NP	5001	<input type="checkbox"/>	
HQ2320/2	9HQCYL/2320	Double Euro Profile	40 × 45	NP	5001	<input type="checkbox"/>	
HQ2325/2	9HQCYL/2325	Double Euro Profile	40 × 50	NP	5001	<input type="checkbox"/>	
HQ2330/2	9HQCYL/2330	Double Euro Profile	40 × 60	NP	5001	<input type="checkbox"/>	
HQ2335/2	9HQCYL/2335	Double Euro Profile	45 × 45	NP	5001	<input type="checkbox"/>	
HQ2340/2	9HQCYL/2340	Double Euro Profile	45 × 55	NP	5001	<input type="checkbox"/>	
HQ2345/2	9HQCYL/2345	Thumb Turn	30 × 30	NP	5001	<input type="checkbox"/>	
HQ2350/2	9HQCYL/2350	Thumb Turn	35 × 35	NP	5001	<input type="checkbox"/>	
HQ2355/2	9HQCYL/2355	Thumb Turn	40 × 40	NP	5001	<input type="checkbox"/>	
HQ2360/2	9HQCYL/2360	Spare Rim Cylinder		Brass	5001	<input type="checkbox"/>	
HQ2365/2	9HQCYL/2365	Spare Rim Cylinder		NP	5001	<input type="checkbox"/>	



ASSA ABLOY

Oval Cylinders



2X13 SCP A	9MORTCYL/060	AA Key & Turn Oval Cylinder		SC	5074	<input type="checkbox"/>	C
------------	--------------	-----------------------------	--	----	------	--------------------------	----------

- Extensive differs, available both 5 or 6 pin • May be supplied to differ, keyed alike or keyed to pass
- May be supplied master keyed • Construction keying, clutch release and classroom functionality available



Rebate Sets



ASSA ABLOY



Article No.	Prod. Code	Description	Size	Finish	Prod. Group		
DY2964 PL	9DYREBATE/080	To Suit Union 2234 Mortice Lock	13mm	PL	5074	<input type="checkbox"/>	<input checked="" type="checkbox"/> A
DY2964 SC	9DYREBATE/085	To Suit Union 2234 Mortice Lock	13mm	SC	5074	<input type="checkbox"/>	

Rebate Sets



Article No.	Description	Size	Finish	Prod. Group		
KX1100	To Suit 3 Lever Sashlocks		NP	5000	<input checked="" type="checkbox"/>	<input checked="" type="checkbox"/> A
KX1105	To Suit 3 Lever Sashlocks		EB	5000	<input checked="" type="checkbox"/>	
KX1110	To Suit BS3621 Sashlocks		PL	5000	<input checked="" type="checkbox"/>	
KX1115	To Suit BS3621 Sashlocks		NP	5000	<input checked="" type="checkbox"/>	

Cylinder Rim Nightlatches



473H PB	9KSCYL/205	Bird Traditional Nightlatch	60mm	GOLD/PB	5000	<input checked="" type="checkbox"/>	
476H PB	9KSCYL/210	Bird Narrow Traditional Nightlatch	40mm	GOLD/PB	5000	<input checked="" type="checkbox"/>	

Cylinder Rim Nightlatches



A



B



C



D



E



F



G



H



I

Article No.	Prod. Code	Description	Size	Finish	Prod. Group		
77 PB	9YACYL77/065	Traditional Nightlatch	60mm	ENB/PB	5098	<input checked="" type="checkbox"/>	A
P77 BLUX	9YABCYLP77/056	Traditional Nightlatch	60mm	BLX/PB	5098	<input type="checkbox"/>	
P77PB	9YABCYLP77/055	Traditional Nightlatch	60mm	ENB/PB	5098	<input type="checkbox"/>	
P77KC ENB	9YABCYLCASE/025	Traditional Nightlatch Case Only	60mm	ENB	5098	<input type="checkbox"/>	

• The Original Yale Lock • 60mm Backset • Standard Security • 2 Year Guarantee

706 PB	9YACYL706/005	Narrow Traditional Nightlatch	40mm	ENB/PB	5098	<input checked="" type="checkbox"/>	B
--------	---------------	-------------------------------	------	--------	------	-------------------------------------	---

81 PB	9YACYL81/076	Rollerbolt Nightlatch	60mm	DMG/PB	5098	<input checked="" type="checkbox"/>	C
-------	--------------	-----------------------	------	--------	------	-------------------------------------	---

• Rollerbolt Operation • 60mm Backset • Standard Security • 2 Year Guarantee

82 PB	9YACYL82/005	Deadbolt Nightlatch	60mm	DMG/PB	5098	<input checked="" type="checkbox"/>	D
-------	--------------	---------------------	------	--------	------	-------------------------------------	---

• Standard security • 2 Year Guarantee

88 PB	9YACYL88/106	Standard Nightlatch	60mm	DMG/PB	5098	<input checked="" type="checkbox"/>	E
-------	--------------	---------------------	------	--------	------	-------------------------------------	---

88 SCP	9YACYL88/111	Standard Nightlatch	60mm	DMG/SC	5098	<input checked="" type="checkbox"/>	
--------	--------------	---------------------	------	--------	------	-------------------------------------	--

P88 PB	9YABCYLP88/081	Standard Nightlatch	60mm	DMG/PB	5098	<input type="checkbox"/>	
--------	----------------	---------------------	------	--------	------	--------------------------	--

• 60mm Backset • Standard Security • 2 Year Guarantee

84 PB	9YACYL84/081	Narrow Nightlatch	40mm	DMG/PB	5098	<input checked="" type="checkbox"/>	
-------	--------------	-------------------	------	--------	------	-------------------------------------	--

P84 PB	9YABCYLP84/061	Narrow Nightlatch	40mm	DMG/PB	5098	<input type="checkbox"/>	
--------	----------------	-------------------	------	--------	------	--------------------------	--

• 40mm Backset • Standard Security • 2 Year Guarantee

P-Y3-BL-PB-60	9YABCYLPY3/005	Contemporary Nightlatch	60mm	BLK/PB	5098	<input type="checkbox"/>	F
---------------	----------------	-------------------------	------	--------	------	--------------------------	---

• Retro-fit replacement for P77 Traditional Nightlatch • No additional chiselling required • 60mm Backset • Standard Security • 2 Year Guarantee

89 PB	9YACYL89/116	Double Locking Deadlatch	60mm	DMG/PB	5098	<input checked="" type="checkbox"/>	G
-------	--------------	--------------------------	------	--------	------	-------------------------------------	---

89 SCP	9YACYL89/126	Double Locking Deadlatch	60mm	DMG/SC	5098	<input checked="" type="checkbox"/>	
--------	--------------	--------------------------	------	--------	------	-------------------------------------	--

P89 SCP	9YABCYLP89/086	Double Locking Deadlatch	60mm	DMG/SC	5098	<input type="checkbox"/>	
---------	----------------	--------------------------	------	--------	------	--------------------------	--

P89 PB	9YABCYLP89/091	Double Locking Deadlatch	60mm	DMG/PB	5098	<input type="checkbox"/>	
--------	----------------	--------------------------	------	--------	------	--------------------------	--

P89/B	9YABCYLP89/095	Double Locking Deadlatch	60mm	BLX/PB	5098	<input type="checkbox"/>	
-------	----------------	--------------------------	------	--------	------	--------------------------	--

P89 CH	9YABCYLP89/100	Double Locking Deadlatch	60mm	CH/CH	5098	<input type="checkbox"/>	
--------	----------------	--------------------------	------	-------	------	--------------------------	--

P89KC DMG 60	9YABCYLCASE/015	Case Only	60mm	DMG	5098	<input type="checkbox"/>	
--------------	-----------------	-----------	------	-----	------	--------------------------	--

• 89 Series • 60mm Backset • For doors with no restriction on width • Supplied with an 1109 cylinder • High Security • 2 Year Guarantee

85 PB	9YACYL85/091	Narrow Double Locking Deadlatch	40mm	DMG/PB	5098	<input checked="" type="checkbox"/>	H
-------	--------------	---------------------------------	------	--------	------	-------------------------------------	---

P85 PB	9YABCYLP85/071	Narrow Double Locking Deadlatch	40mm	DMG/PB	5098	<input type="checkbox"/>	
--------	----------------	---------------------------------	------	--------	------	--------------------------	--

P85/B	9YABCYLP85/075	Narrow Double Locking Deadlatch	40mm	BLX/PB	5098	<input type="checkbox"/>	
-------	----------------	---------------------------------	------	--------	------	--------------------------	--

P85 CH	9YABCYLP85/080	Narrow Double Locking Deadlatch	40mm	CH/CH	5098	<input type="checkbox"/>	
--------	----------------	---------------------------------	------	-------	------	--------------------------	--

P85KC DMG	9YABCYLCASE/005	Case Only	40mm	DMG	5098	<input type="checkbox"/>	
-----------	-----------------	-----------	------	-----	------	--------------------------	--

• 85 Series • 40mm Backset • Recommended for doors where there is a restricted width to mount a lock • Supplied with an 1109 cylinder

• High Security • 2 Year Guarantee

P/BS1/BLX/PB/60	9YABCYLBBS1/005	Twin Cylinder Rimlock	60mm	BLX/PB	5098	<input type="checkbox"/>	I
-----------------	-----------------	-----------------------	------	--------	------	--------------------------	---

P/BS1/CH/CH/60	9YABCYLBBS1/015	Twin Cylinder Rimlock	60mm	CH/CH	5098	<input type="checkbox"/>	
----------------	-----------------	-----------------------	------	-------	------	--------------------------	--

• Kitemarked to BS3621:2007 • Complies to the standard BS EN 12209:2003 & BS EN 1303:2005 • CE marked – suitable for use on FD60 timber fire doors

• Recommended by insurance companies and the Police • Supplied with anti-drill, anti-pick and anti-bump 6 pin rim cylinder • Anti-carding protection

• 20mm bolt for increased strength • 60mm Backset • Maximum Security • 10 Year Guarantee



Rim Locks



Article No.	Prod. Code	Description	Size	Finish	Prod. Group		
P334 GREY	9YABRIMP334/005	Rim Lock	156mm	Grey	5098		

• For use with rim knobs • 156mm x 104mm • Standard Security • 2 Year Guarantee

P401 GREY	9YABRIMP401/010	Narrow Rim Lock	138mm	Grey	5098		
-----------	-----------------	-----------------	-------	------	------	--	--

• For use with rim knobs • 138mm x 76mm • Standard Security • 2 Year Guarantee



Rim Locks



DY1445 CG	9DYRIML/015	Rim Lock	153mm	CG	5074		
1445 6.0"	9RIML/020	Rim Lock	153mm	BJ	5074		

• The deadbolt is locked or unlocked by key from either side • The latch bolt is withdrawn by knob from either side
• Backset: 51mm • Case & Keep: Steel, black enamel finish



1448 5.5"	9RIML/025	Rim Lock	140mm	BJ	5074		
-----------	-----------	----------	-------	----	------	--	--

• The deadbolt is locked or unlocked by key from either side • The latch bolt is withdrawn by knob from either side
• Backset: 51mm • Case & Keep: Steel, black enamel finish



1439 LH 6.0"	9RIML/010	Handed Rim Lock LH	155mm	BJ	5074		
1439 RH 6.0"	9RIML/015	Handed Rim Lock RH	155mm	BJ	5074		

• The deadbolt is locked or unlocked by key from either side • The latch bolt is withdrawn by knob from either side
• Backset: 53mm • Case & Keep: Steel, black enamel finish



Rim Locks

Article No.	Prod. Code	Description	Size	Finish	Prod. Group		
KX142	9KXRIML/142	Narrow Rimlock	140 x 76mm	BLK	5000		



KX131	9KXRIM/131	Contract Narrow Rimlock-Differ	140 x 76mm	BLK	5000		
KX130	9KXRIM/130	Contract Narrow Rimlock - To Pass (Reversible)	140 x 76mm	BLK	5000		



KX140	9KXRIML/140	Fluted Edge Rimlock	150 x 100mm	BLK	5000		
-------	-------------	---------------------	-------------	-----	------	--	--



KX144	9KXRIML/144	Rim Deadlock	100 x 76mm	BLK	5000		
-------	-------------	--------------	------------	-----	------	--	--

KX146	9KXRIML/146	Rimlatch	100 x 76mm	BLK	5000		
-------	-------------	----------	------------	-----	------	--	--



Rim Locks



Article No.	Prod. Code	Description	Finish	Prod. Group		
HQ2500/2	9HQRIM/2500	Rim Lock 150 x 100mm	BLK	5001	<input type="checkbox"/>	
HQ2505/2	9HQRIM/2505	Rim Lock 140 x 76mm	BLK	5001	<input type="checkbox"/>	
HQ2510/2	9HQRIM/2510	Rim Dead Lock 100 x 75mm	BLK	5001	<input type="checkbox"/>	
HQ2515/2	9HQRIM/2515	Rim Latch 100 x 75mm	BLK	5001	<input type="checkbox"/>	



Press Locks

Article No.	Prod. Code	Description	Size	Finish	Prod. Group		
KX938	9KXSEC/938	Contract Presslock	65mm	BLK	5000	<input checked="" type="checkbox"/>	<input checked="" type="checkbox"/>
KX940	9KXSEC/940	Contract Presslock	76mm	BLK	5000	<input type="checkbox"/>	<input type="checkbox"/>

• Standard Asian pattern with 1 long key



Rim Cylinders



Article No.	Prod. Code	Description	Finish	Prod. Group		
1109PB	9YACYL1109/140	Rim Cylinder	PB	5098	<input checked="" type="checkbox"/>	<input checked="" type="checkbox"/>
1109SCP	9YACYL1109/145	Rim Cylinder	SC	5098	<input checked="" type="checkbox"/>	<input checked="" type="checkbox"/>
P1109 PB	9YABRCP1109/005	Rim Cylinder	PB	5098	<input type="checkbox"/>	<input type="checkbox"/>
P1109 SCP	9YABRCP1109/010	Rim Cylinder	SC	5098	<input type="checkbox"/>	<input type="checkbox"/>
4KP1109PB	9YABCYLCASE/060	Key Choice Cylinder & 4 Keys	PB	5098	<input type="checkbox"/>	<input type="checkbox"/>
6KP1109PB	9YABCYLCASE/065	Key Choice Cylinder & 6 Keys	PB	5098	<input type="checkbox"/>	<input type="checkbox"/>

• Replacement 5 pin Rim Cylinder • Suitable for doors 38mm to 57mm in thickness • Standard Security level • 2 Year Guarantee



Rim Cylinders

480H 555	9KSCYL/250	Pin Rim Cylinder	PB	5000	<input checked="" type="checkbox"/>	<input checked="" type="checkbox"/>
----------	------------	------------------	----	------	-------------------------------------	-------------------------------------



Digital Door Locks



Article No.	Prod. Code	Description	Finish	Prod. Group		
HQ2031/1	9HQDIGITALSCP/2031	Push Button Digital Lock & Holdback	SCP	5001	<input type="checkbox"/>	A
HQ2033/1	9HQDIGITALSN/2033	Push Button Digital Lock & Holdback	SN	5001	<input type="checkbox"/>	B
HQ2029/1	9HQDIGITALSCP/2029	Push Button Digital Lock with Handle	SCP	5001	<input type="checkbox"/>	C
HQ2039/1	9HQDIGITALEB/2039	Mini Push Button Digital Lock	EB	5001	<input type="checkbox"/>	D
HQ2037/1	9HQDIGITALSN/2037	Mini Push Button Digital Lock	SN	5001	<input type="checkbox"/>	E

- Interior or exterior use • Reversible with clutch protection • Large indented push buttons, engraved not painted
- Lock with holdback has 5,000 combinations • Lock with handle has 8,000 combinations • Mini lock has 3,000 combinations



Padlocks



Article No.	Prod. Code	Description	Size	Finish	Prod. Group		
713	9YAPL713/005	Diecast Padlock	40mm	Zinc	5098	<input type="checkbox"/>	A

- Zinc body • Hardened steel sprung shackle



P220/51/118/1	9YABPLP220/005	Weatherproof Padlock	51mm	Steel	5098	<input type="checkbox"/>	B
---------------	----------------	----------------------	------	-------	------	--------------------------	---

- Solid multi layered steel body protection system • Keyway cover cap to prevent rusting • Double ball bearing lock for added security



Padlocks



Article No.	Prod. Code	Description	Size	Finish	Prod. Group		
KX151	9KXPAD/151	Brass Padlock	25mm	Brass	5000	<input type="checkbox"/>	A
KX152	9KXPAD/152	Brass Padlock	30mm	Brass	5000	<input type="checkbox"/>	
KX153	9KXPAD/153	Brass Padlock	40mm	Brass	5000	<input type="checkbox"/>	
KX154	9KXPAD/154	Brass Padlock	50mm	Brass	5000	<input type="checkbox"/>	
KX155	9KXPAD/155	Brass Padlock	60mm	Brass	5000	<input type="checkbox"/>	
KP150	9KPPAD/150	Brass Padlock	20mm	Brass	5001	<input type="checkbox"/>	
KP151	9KPPAD/151	Brass Padlock	25mm	Brass	5001	<input type="checkbox"/>	
KP152	9KPPAD/152	Brass Padlock	30mm	Brass	5001	<input type="checkbox"/>	
KP153	9KPPAD/153	Brass Padlock	40mm	Brass	5001	<input type="checkbox"/>	
KP154	9KPPAD/154	Brass Padlock	50mm	Brass	5001	<input type="checkbox"/>	
KP155	9KPPAD/155	Brass Padlock	60mm	Brass	5001	<input type="checkbox"/>	
KX158	9KXPAD/158	Brass Padlock to Pass	40mm	Brass	5000	<input type="checkbox"/>	
KX159	9KXPAD/159	Brass Padlock to Pass	50mm	Brass	5000	<input type="checkbox"/>	
KX160	9KXPAD/160	Brass Padlock to Pass	60mm	Brass	5000	<input type="checkbox"/>	



Padlocks



- Solid Brass Body / Pin Tumbler Mechanism



- Hardened Steel Shackle / Double Locking / Pin Tumbler Mechanism



- Hardened Steel Shackle / Double Locking / Pin Tumbler Mechanism



- Hardened Steel Long Shackle / Double Locking / Pin Tumbler Mechanism



- 2 Locks Working From 1 Key / Hardened Steel Shackle / Double Locking



- Hardened Steel Shackle / Double Locking / Pin Tumbler Mechanism



- Solid Brass Body / Pin Tumbler Mechanism



- Solid Brass Body / Pin Tumbler Mechanism



- Solid Brass Body / Pin Tumbler Mechanism



- Forged Steel Shackle & Steel Case / 4 Lever lock mechanism / Keyhole Cover



- Forged Steel Shackle & Steel Case / 4 Lever lock mechanism / Keyhole Cover



- Forged Steel Shackle & Steel Case / 4 Lever lock mechanism / Keyhole Cover

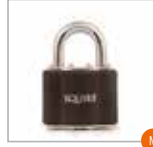

- Hardened Steel Shackle / Double Deadlocking / Covered Steel Body with anti corrosion finish

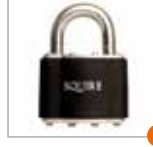

- Hardened Steel Shackle / Double Deadlocking / Covered Steel Body with anti corrosion finish

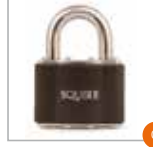

- Hardened Steel Shackle / Double Deadlocking / Covered Steel Body with anti corrosion finish



- Hardened Steel Closed Shackle / Double Deadlocking / Covered Steel Body with anti corrosion finish



- Steel Shackle / Solid Brass Body / Resettable Combination, 1,000s of Combinations



- Steel Shackle / Solid Brass Body / Resettable Combination, 1,000s of Combinations



- Hardened Steel 8mm Shackle / Highly resistant to corrosion, excellent weather protection / 10,000 possible combinations



- Hardened Steel 8mm Shackle Diameter, Long Shackle / Highly resistant to corrosion, excellent weather protection / 10,000 possible combinations

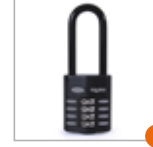

- Hardened Steel 8mm Shackle Diameter, Long Shackle / Highly resistant to corrosion, excellent weather protection / 10,000 possible combinations



- Hardened Steel Construction with Anti corrosion finish / Coach bolt fixings for added security / Can be used on single and double doors

Article No.	Prod. Code	Description	Size	Finish	Prod. Group		
LN2	9SQUIREPAD/017	Brass Padlock	25mm	Brass	5095	<input type="checkbox"/>	A
LN3	9SQUIREPAD/018	Brass Padlock	30mm	Brass	5095	<input type="checkbox"/>	B
LN4	9SQUIREPAD/019	Brass Padlock	40mm	Brass	5095	<input type="checkbox"/>	C
LN4/2.1/2"	9SQUIREPAD/021	Brass Padlock 2.1/2" Shackle	40mm	Brass	5095	<input type="checkbox"/>	D
LN4T	9SQUIREPAD/022	Brass Padlock Keyed Alike Twin Pack	40mm	Brass	5095	<input type="checkbox"/>	E
LN5	9SQUIREPAD/020	Brass Padlock	50mm	Brass	5095	<input type="checkbox"/>	F
LP6	9SQUIREPAD/026	Brass Padlock	20mm	Brass	5095	<input type="checkbox"/>	G
LP7	9SQUIREPAD/027	Brass Padlock	25mm	Brass	5095	<input type="checkbox"/>	H
LP8	9SQUIREPAD/028	Brass Padlock	30mm	Brass	5095	<input type="checkbox"/>	I
220	9SQUIREPAD/105	Old English Padlock	40mm	Galv	5095	<input type="checkbox"/>	J
440	9SQUIREPAD/110	Old English Padlock	50mm	Galv	5095	<input type="checkbox"/>	K
660	9SQUIREPAD/115	Old English Padlock	65mm	Galv	5095	<input type="checkbox"/>	L
35	9SQUIREPAD/155	Stronglock Pin Tumbler Padlock	40mm	Lam Stl	5095	<input type="checkbox"/>	M
37	9SQUIREPAD/160	Stronglock Pin Tumbler Padlock	45mm	Lam Stl	5095	<input type="checkbox"/>	N
39	9SQUIREPAD/165	Stronglock Laminated Padlock 2 Tumbler	50mm	Lam Stl	5095	<input type="checkbox"/>	O
39CS	9SQUIREPAD/163	Stronglock Pin Tumbler Padlock Closed Shackle	50mm	Lam Stl	5095	<input type="checkbox"/>	P
CTL1	9SQUIREPAD/330	Combination Padlock Luggage/Toolbox	30mm	Brass	5095	<input type="checkbox"/>	Q
CSL1	9SQUIREPAD/335	Recodable Combination Padlock	40mm	Brass	5095	<input type="checkbox"/>	R
CP50	9SQUIREPAD/220	Recodable Combination Padlock	50mm	Steel	5095	<input type="checkbox"/>	S
CP50/1.5	9SQUIREPAD/225	Recodable Combination Padlock 1.1/2" Shackle	50mm	Steel	5095	<input type="checkbox"/>	T
CP50/2.5	9SQUIREPAD/230	Recodable Combination Padlock 2.1/2" Shackle	50mm	Steel	5095	<input type="checkbox"/>	U
NO.6H	9SQUIREHS/020	Maxiclam Hasp & Staple	152mm	Steel	5095	<input type="checkbox"/>	V



Door Locks/Bolts



PM444-PB	9YABMLP444/002	Door Security Bolt (1 Bolt + 1 Key)	PB	5098	<input type="checkbox"/>	D
P-2PM444-PB-2	9YABMLP444/005	Door Security Bolt (2 Bolts + 1 Key)	PB	5098	<input type="checkbox"/>	
PM-444-WE	9YABMLP444/008	Door Security Bolt (1 Bolt + 1 Key)	WE	5098	<input type="checkbox"/>	
P-2PM444-WE-2	9YABMLP444/010	Door Security Bolt (2 Bolts + 1 Key)	WE	5098	<input type="checkbox"/>	



Door Locks/Bolts



KX212	9KXSEC/212	Rack Bolt Only 2.3/8"	EB	5000	<input checked="" type="checkbox"/>	A
HQ2061/2	9HQRACKEB/2061	Rack Bolt & Key (Pack of 2) 2.3/8"	EB	5001	<input type="checkbox"/>	

• Brass bolt with extra long throw for improved security

KX214	9KXSEC/214	Rack Bolt Key	Red	5000	<input checked="" type="checkbox"/>	B
HQ2059/2	9HQRACKKEY/2059	Rack Bolt Key (Pack of 2)	Red	5001	<input type="checkbox"/>	

• Universal rack bolt key

Window Locks/Bolts

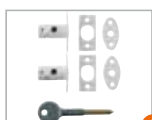

Article No.	Prod. Code	Description	Finish	Prod. Group	<input type="checkbox"/>	A
V8001-2-PL	9YABWBV8001/005	Window Security Bolt (Pack of 2)	PL	5098	<input type="checkbox"/>	A
8001/K/P25	9CHUSB8001/020	Keys for 8001 (Pack of 2)		5098	<input type="checkbox"/>	
B-8001-KX	9CHUSB8001/025	Long Key for 8001/8002		5098	<input checked="" type="checkbox"/>	



P117 WHITE	9YABWLP117/005	Ventilation Window Lock	WE	5098	<input type="checkbox"/>	B
------------	----------------	-------------------------	----	------	--------------------------	----------



P-6P119-6	9YABWLP6P119/005	Sash Window Bolt (Pack of 6)	PB	5098	<input type="checkbox"/>	C
-----------	------------------	------------------------------	----	------	--------------------------	----------



8013	9CHUDS8013/005	Sliding Sash Window Bolt (Pack of 2)	PB	5098	<input type="checkbox"/>	D
8013/K	9CHUDS8013/010	Keys for 8013 (Pack of 2)		5098	<input type="checkbox"/>	



8K101/M BN	9CHUWC8K101/002	Pivoted Window Catch (4 Catches + 1 Key)	BN	5098	<input type="checkbox"/>	
8K101/M	9CHUWC8K101/004	Pivoted Window Catch (4 Catches + 1 Key)	WE	5098	<input type="checkbox"/>	E
8K101/K	9CHUWC8K101/010	Keys for 8K101 (Pack of 2)		5098	<input type="checkbox"/>	

ALL PRODUCTS • Standard Security • 2 Year Guarantee

Window Locks/Bolts



A

Article No.	Prod. Code	Description	Finish	Prod. Group		
HQ2053/2	9HQSTAYLOCKEB/2053	Staylock (Pk2)	EB	5001	<input type="checkbox"/>	A

Locking Window Stays and Fasteners



A

P YWHLCK40N PC	9YABHANPC/010	PVCU Window Handle	PC	5098	<input type="checkbox"/>	A
P YWHLCK40N WH	9YABHANWH/010	PVCU Window Handle	WH	5098	<input type="checkbox"/>	

• Standard Security • 2 Year Guarantee

Locking Window Stays and Fasteners



A

HQ1839/4	9HQSTAYLOCK/1839	Locking Casement Stay 10"	White	5001	<input type="checkbox"/>	A
HQ1841/4	9HQSTAYLOCK/1841	Locking Casement Stay 10"	GL	5001	<input type="checkbox"/>	



B

HQ1833/4	9HQCFASTLOCK/1833	Locking Casement Fastener	SCP	5001	<input type="checkbox"/>	B
HQ1843/4	9HQCFASTLOCK/1843	Locking Casement Fastener	White	5001	<input type="checkbox"/>	
HQ1845/4	9HQCFASTLOCK/1845	Locking Casement Fastener	GL	5001	<input type="checkbox"/>	



Door Viewers



Article No.	Prod. Code	Description	Finish	Prod. Group		
P9401 PB	9YABDVP9401/005	Door Viewer	PB	5098	<input type="checkbox"/>	<input checked="" type="checkbox"/> A

• Standard Security • 2 Year Guarantee



Door Viewers



Article No.	Prod. Code	Description	Finish	Prod. Group		
KX240	9KXSEC/240	Door Viewer 160°	CP	5000	<input checked="" type="checkbox"/>	<input checked="" type="checkbox"/> A
KX239	9KXSEC/239	Door Viewer 160°	EB	5000	<input checked="" type="checkbox"/>	
HQ1571/2	9HQVIEWERCP/1571	Door Viewer 160°	CP	5001	<input type="checkbox"/>	

• Easy to install • Suitable for doors 25mm to 57mm thick



Door Chains



WS6/02	9CHUDCWS6/015	Doormaster Chain	SC	5098	<input type="checkbox"/>	<input checked="" type="checkbox"/> A
--------	---------------	------------------	----	------	--------------------------	---------------------------------------

• Approved to DHF TS003:2012 • Door Chains & Limiters • Secured By Design approved • High Security • 2 Year Guarantee



Door Chains



HQ2069/2	9HQCHAINED/2069	Security Door Chain	EB	5001	<input type="checkbox"/>	<input checked="" type="checkbox"/> A
HQ2071/2	9HQCHAINSCP/2071	Security Door Chain	SCP	5001	<input type="checkbox"/>	



HQ1245/2	9HQCHAINPB/1245	Contract Door Chain	EB	5001	<input type="checkbox"/>	<input checked="" type="checkbox"/> B
HQ1569/2	9HQCHAINCP/1569	Contract Door Chain	CP	5001	<input type="checkbox"/>	

Bolts

Straight Tower Bolts

A standard bolt often used on shed doors



Boxed

Article No.	Prod. Code	Size	No. of screws Size mm	Screw size / Size mm	Finish	Unit of Sale	Prod. Group
923A 3	9TQIJTB/006	3"	75	8g/6	EXB	10	5000
923A 4	9TQIJTB/011	4"	100	8g/8	EXB	10	5000
923A 6	9TQIJTB/016	6"	150	8g/8	EXB	10	5000
923A 8	9TQIJTB/021	8"	200	8g/10	EXB	10	5000
923A 10	9TQIJTB/026	10"	250	8g/10	EXB	10	5000
923A 12	9TQIJTB/031	12"	300	8g/10	EXB	10	5000
923AZP 075	9TQIZPTB/006	3"	75	8g/6	BZP	10	5000
923AZP 100	9TQIZPTB/011	4"	100	8g/8	BZP	10	5000
923AZP 150	9TQIZPTB/016	6"	150	8g/8	BZP	10	5000
923AZP 200	9TQIZPTB/021	8"	200	8g/10	BZP	10	5000
923AZP 250	9TQIZPTB/026	10"	250	8g/10	BZP	10	5000
923AZP 300	9TQIZPTB/031	12"	300	8g/10	BZP	10	5000
923A GALV3	9BZTB/005	3"	75	8g/6	Galv	10	5000
923A GALV4	9BZTB/010	4"	100	8g/8	Galv	10	5000
923A GALV6	9BZTB/015	6"	150	8g/8	Galv	10	5000
923A GALV8	9BZTB/020	8"	200	8g/10	Galv	10	5000

Pre-packed

HQ1847/4	9HQTOWEREXB/1847	3"	75	8g/6	EXB	4 Bags	5001
HQ1849/4	9HQTOWEREXB/1849	4"	100	8g/8	EXB	4 Bags	5001
HQ1851/4	9HQTOWEREXB/1851	6"	150	8g/8	EXB	4 Bags	5001
HQ1853/4	9HQTOWEREXB/1853	8"	200	8g/10	EXB	4 Bags	5001
HQ1854/4	9HQTOWEREXB/1854	10"	250	8g/10	EXB	4 Bags	5001
HQ1859/4	9HQTOWERGALV/1859	4"	100	8g/8	BZP	4 Bags	5001
HQ1861/4	9HQTOWERGALV/1861	6"	150	8g/8	BZP	2 Bags	5001
HQ1863/4	9HQTOWERGALV/1863	8"	200	8g/10	BZP	2 Bags	5001
HQ1860/4	9HQTOWERGALV/1860	4"	100	8g/10	Galv	2 Bags	5001
HQ1862/4	9HQTOWERGALV/1862	6"	150	8g/10	Galv	4 Bags	5001
HQ1864/4	9HQTOWERGALV/1864	8"	200	8g/10	Galv	4 Bags	5001





Necked Tower Bolts

Used to bolt double doors with a recessed frame. Uses a flat plate instead of a staple.

Boxed

Article No.	Prod. Code	Size	No. of screws Size mm	Screw size l	Finish	Unit of Sale	Prod. Group
923AN 100	9TQIJNTB/005	4"	100	8g/4	EXB	10	5000
923AN 150	9TQIJNTB/010	6"	150	8g/6	EXB	10	5000
923AN 200	9TQIJNTB/015	8"	200	8g/10	EXB	10	5000
923AN Z100	9TQIZPNTB/005	4"	100	8g/4	BZP	10	5000
923AN Z150	9TQIZPNTB/010	6"	150	8g/6	BZP	10	5000
923AN Z200	9TQIZPNTB/015	8"	200	8g/10	BZP	10	5000

Pre-packed

HQ1865/4	9HQ TOWEREXBN/1865	4"	100	8g/4	EXB	4Bags	5001
HQ1867/4	9HQ TOWEREXBN/1867	6"	150	8g/6	EXB	4 Bags	5001



Black Antique Straight Door Bolts

Boxed

Article No.	Prod. Code	Size	Size mm	Finish	Unit of Sale	Prod. Group
KX977	9KXANTIQUE/977	4"	100	EXB	5	5000
KX980	9KXANTIQUE/980	6"	150	EXB	5	5000

Pre-packed

HQ1467/4	9HQ BOLT BANT/1467	5"	127	EXB	4 Bags	5001
----------	--------------------	----	-----	-----	--------	------



Black Antique Necked Door Bolts

Boxed

KX981	9KXANTIQUE/981	4"	100	EXB	5	5000
KX982	9KXANTIQUE/982	5"	127	EXB	5	5000
KX983	9KXANTIQUE/983	6"	150	EXB	5	5000

Bolts

Straight Barrel Bolts

Brass: Extruded brass bolt with a brass shoot



Boxed

Article No.	Prod. Code	Size	No. of screws / Size mm	Screw size / Size mm	Finish	Unit of Sale	Prod. Group
280 2.0	9TQIABB/005	2" x 1"	50 x 25	4g/6	Alum	10	5000
280 3.0	9TQIABB/015	3" x 1"	75 x 25	4g/6	Alum	10	5000
280 4.0	9TQIABB/020	4" x 1"	100 x 25	4g/6	Alum	10	5000
220 1.5	9TQIBBB/005	1.1/2" x 1"	40 x 25	4g/6	Brass	10	5000
220 2.0	9TQIBBB/010	2" x 1"	50 x 25	4g/6	Brass	10	5000
220 2.5	9TQIBBB/015	2.1/2" x 1"	65 x 25	4g/6	Brass	10	5000
220 3.0	9TQIBBB/020	3" x 1"	75 x 25	4g/6	Brass	10	5000
220 4.0	9TQIBBB/025	4" x 1"	100 x 25	4g/6	Brass	10	5000
220 2.0CP	9TQICPBB/010	2" x 1"	50 x 25	4g/6	CP/B	10	5000
220 2.5CP	9TQICPBB/015	2.1/2" x 1"	65 x 25	4g/6	CP/B	10	5000
220 3.0CP	9TQICPBB/020	3" x 1"	75 x 25	4g/6	CP/B	10	5000
220 4.0CP	9TQICPBB/025	4" x 1"	100 x 25	4g/6	CP/B	10	5000

Pre-packed



HQ1039/4	9HQBARRELAA/1039	2" x 1"	50 x 25	4g/6	Alum	4 Bags	5001
HQ1045/4	9HQBARRELAA/1045	4" x 1"	100 x 25	4g/6	Alum	4 Bags	5001
HQ1047/4	9HQBARRELAA/1047	6" x 1"	150 x 25	4g/6	Alum	4 Bags	5001
HQ1353/4	9HQBARRELBR/1353	2" x 1"	50 x 25	4g/6	Brass	4 Bags	5001
HQ1355/4	9HQBARRELBR/1355	2.1/2" x 1"	65 x 25	4g/6	Brass	4 Bags	5001
HQ1357/4	9HQBARRELBR/1357	3" x 1"	75 x 25	4g/6	Brass	4 Bags	5001
HQ1359/4	9HQBARRELBR/1359	4" x 1"	100 x 25	4g/6	Brass	4 Bags	5001
HQ1361/4	9HQBARRELBR/1361	6" x 1"	150 x 25	4g/6	Brass	4 Bags	5001
HQ1363/2	9HQBARRELBRHD/1363	6" x 1.1/2"	150 x 38	6g/10	Brass	2 Bags	5001
HQ1549/4	9HQBARRELCP/1549	1.1/2" x 1"	40 x 25	4g/6	CP/B	4 Bags	5001
HQ1551/4	9HQBARRELCP/1551	2" x 1"	50 x 25	4g/6	CP/B	4 Bags	5001
HQ1553/4	9HQBARRELCP/1553	2.1/2" x 1"	65 x 25	4g/6	CP/B	4 Bags	5001
HQ1555/4	9HQBARRELCP/1555	3" x 1"	75 x 25	4g/6	CP/B	4 Bags	5001
HQ1557/4	9HQBARRELCP/1557	4" x 1"	100 x 25	4g/6	CP/B	4 Bags	5001
HQ1559/4	9HQBARRELCP/1559	6" x 1"	150 x 25	4g/6	CP/B	4 Bags	5001



Necked Barrel Bolts

Aluminium: Extruded aluminium bolt with a BZP steel shoot

Brass: Extruded brass bolt with a brass shoot / Use necked for recessed applications



Boxed

Article No.	Prod. Code	Size	No. of screws Size mm	Screw size / Screws	Finish	Unit of Sale	Prod. Group
285 4.0	9TQIABBN/010	4" x 1"	100 x 25	4g/6	Alum	10	5000
240 2.0	9TQIBBBN/005	2" x 1"	50 x 25	4g/6	Brass	10	5000
240 2.5	9TQIBBBN/010	2.1/2" x 1"	65 x 25	4g/6	Brass	10	5000
240 3.0CP	9TQICPBBN/015	3" x 1"	75 x 25	4g/6	CP/B	10	5000
240 4.0CP	9TQICPBBN/020	4" x 1"	100 x 25	4g/6	CP/B	10	5000

Pre-packed



HQ1051/4	9HQBARRELAAN/1051	4" x 1"	100 x 25	4g/6	Alum	4 Bags	5001
HQ1367/4	9HQBARRELB RN/1367	3" x 1"	75 x 25	4g/6	Brass	4 Bags	5001
HQ1369/4	9HQBARRELB RN/1369	4" x 1"	100 x 25	4g/6	Brass	4 Bags	5001
HQ1371/4	9HQBARRELB RN/1371	6" x 1"	150 x 25	4g/6	Brass	4 Bags	5001
HQ1561/4	9HQBARRELC PN/1561	2" x 1"	50 x 25	4g/6	CP/B	4 Bags	5001
HQ1563/4	9HQBARRELC PN/1563	3" x 1"	75 x 25	4g/6	CP/B	4 Bags	5001
HQ1565/4	9HQBARRELC PN/1565	4" x 1"	100 x 25	4g/6	CP/B	4 Bags	5001
HQ1567/4	9HQBARRELC PN/1567	6" x 1"	150 x 25	4g/6	CP/B	4 Bags	5001

1A Heavy Pattern, Brenton Pattern Pad Bolts

For heavy duty applications. Use 6mm diameter coach bolts when fixing.



Boxed

1A 6GALV	9GALVBPB/023	6" x 5/8"	150 x 16	8g/6	Galv	5	5000
1A 8	9GALVBPB/025	8" x 5/8"	200 x 16	8g/6	Galv	5	5000
1A 10	9GALVBPB/030	10" x 5/8"	250 x 16	8g/6	Galv	5	5000
1A 12GALV	9GALVBPB/033	12" x 5/8"	300 x 16	8g/6	Galv	5	5000

Bolts

2A Brenton Pattern Pad Bolts

Use a 6mm diameter coach bolt when fixing



Boxed

Article No.	Prod. Code	Size	No. of screws / Size mm	Screw size / Size mm	Finish	Unit of Sale	Prod. Group
2AEXB 100	9TQIEXBBPB/005	4" x 1/2"	100 x 12	8g / 6	EXB	5	5000
2AEXB 150	9TQIEXBBPB/010	6" x 1/2"	150 x 12	8g / 6	EXB	5	5000
2AEXB 200	9TQIEXBBPB/015	8" x 1/2"	200 x 12	8g / 6	EXB	5	5000
2A 4ZP	9TQIGALVBPB/005	4" x 1/2"	100 x 12	8g / 6	BZP	5	5000
2A 6ZP	9TQIGALVBPB/006	6" x 1/2"	150 x 12	8g / 6	BZP	5	5000
2A 8ZP	9TQIGALVBPB/011	8" x 1/2"	200 x 12	8g / 6	BZP	5	5000
2A 10ZP	9TQIGALVBPB/016	10" x 1/2"	250 x 12	8g / 6	BZP	5	5000
2A 4GALV	9GALVBPB/003	4" x 1/2"	100 x 12	8g / 6	Galv	5	5000
2A 6GALV	9GALVBPB/005	6" x 1/2"	150 x 12	8g / 6	Galv	5	5000
2A 8GALV	9GALVBPB/010	8" x 1/2"	200 x 12	8g / 6	Galv	5	5000
2A 10GALV	9GALVBPB/015	10" x 1/2"	250 x 12	8g / 6	Galv	5	5000
2A 12GALV	9GALVBPB/020	12" x 1/2"	300 x 12	8g / 6	Galv	5	5000

Pre-packed

HQ1869/4	9HQPADBOLT/1869	100mm	8g / 6	BZP	4 Bags	5001
HQ1871/4	9HQPADBOLT/1871	150mm	8g / 6	BZP	1 Bag	5001
HQ1873/4	9HQPADBOLT/1873	200mm	8g / 6	BZP	1 Bag	5001
HQ1872/4	9HQPADBOLT/1872	150mm	8g / 6	Galv	1 Bag	5001
HQ1874/4	9HQPADBOLT/1874	200mm	8g / 6	Galv	1 Bag	5001
HQ2221/4	9HQPADBOLT/2221	100mm	8g / 6	EXB	1 Bag	5001
HQ2223/4	9HQPADBOLT/2223	150mm	8g / 6	EXB	1 Bag	5001
HQ2225/4	9HQPADBOLT/2225	200mm	8g / 6	EXB	1 Bag	5001



5A Slimline Brenton Pattern Pad Bolts

Suitable for applications with thinner timber dimensions, such as rabbit hutches



Boxed

5A 4ZP	9TQIGALVBPB/004	4" x 1/2"	100 x 12	8g / 6	BZP	10	5000
5A 6ZP	9TQIGALVBPB/007	6" x 1/2"	150 x 12	8g / 6	BZP	5	5000

4A Oval Pattern Pad Bolts

Suitable for applications with width restrictions



Boxed

4A BZP	9TQIZPOPB/006	4"	100	8g / 4	BZP	10	5000
4A	9GALVOPB/005	4"	100	8g / 4	Galv	10	5000

Pre-packed

HQ1875/4	9HQPADBOLT/1875	5"	115mm	8g / 4	BZP	4 Bags	5001
HQ1876/4	9HQPADBOLT/1876	5"	115mm	8g / 4	Galv	4 Bags	5001





Flush Bolts



Lever action bolt, that sits in the rebate. For flush fitting on the door face.
Used to secure double doors.

Boxed

Article No.	Prod. Code	Size	No. of screws / Size mm	Screw size / Finish	Unit of Sale	Prod. Group
680	9TQIAFB/005	6" x 3/4"	150 x 19	6g/5 Alum	10	5000

Pre-packed



HQ1377/4	9HQBOLTFBBR/1377	6" x 3/4"	150 x 19	6g/5	PLB	4 Bags	5001
HQ1669/4	9HQBOLTFBCP/1669	6" x 3/4"	150 x 19	6g/5	CP/B	4 Bags	5001

Surface Slide Bolts



Boxed

290 6.0	9TQITSB/005	152mm	6g/10	PLB	5	5000
---------	-------------	-------	-------	-----	---	------

Pre-packed

HQ1373/4	9HQBOLTSBBR/1373	100mm	6g/6	PLB	4 Bags	5001
----------	------------------	-------	------	-----	--------	------



• A more substantial door bolt

Bolts

Foot Bolts



Boxed

Article No.	Prod. Code	Size	Size mm	No. of screws / Screw size /	Finish	Unit of Sale	Prod. Group
68EXB	9JFB/005	7" x 2"	175 x 50	10g / 8	EXB	5	5000
68GALV	9GALVFB/005	7" x 2"	175 x 50	10g / 8	Galv	5	5000

• For use at the bottom of the door • The bolt is thrown by pressing the sole of the foot down on the plate

Chain Bolts

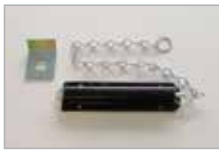

Boxed

66EXB	9JCB/005	8.1/2"	200	10g / 8	EXB	5	5000
66GALV	9GALVCB/005	8.1/2"	200	10g / 8	Galv	5	5000

• For use at the top of a garage door, with vertical insertion • The chain is pulled to release the bolt

Heavy Cross Bolts



Boxed

597 GALV12	9GALVHCB/005	12"	300	12g / 18	Galv	2	5000
597 GALV18	9GALVHCB/010	18"	450	12g / 18	Galv	2	5000

• Horizontal bolt, often used on agricultural buildings

Light Garage Door Bolts



Boxed

1260L 300EXB	9EXBGDB/005	300mm	10g / 12	EXB	5	5000
1260L 375EXB	9EXBGDB/010	375mm	10g / 12	EXB	5	5000
1260L 450EXB	9EXBGDB/015	450mm	10g / 12	EXB	4	5000
1260L 600EXB	9EXBGDB/020	600mm	10g / 12	EXB	4	5000
1260L 300BZP	9ZPGDB/005	300mm	10g / 12	BZP	5	5000
1260L 375BZP	9ZPGDB/010	375mm	10g / 12	BZP	5	5000
1260L 450BZP	9ZPGDB/015	450mm	10g / 12	BZP	5	5000

• Can be used with both single and double garage doors



Heavy Garage Door Bolts

Boxed

Article No.	Prod. Code	No. of screws / Size	Screw size / Finish	Unit of Sale	Prod. Group
1260	9JGDB/010	300mm	12g / 16	EXB	1 5000
1260H 300HSG	9GALVGDB/005	300mm	12g / 16	HSG	1 5000
1260H 450HSG	9GALVGDB/010	450mm	12g / 16	HSG	1 5000
1260H 600HSG	9GALVGDB/015	600mm	12g / 16	HSG	1 5000

• Can be used with both single and double garage doors



Garage Door Holders

Boxed



Article No.	Prod. Code	Size	Finish	Unit of Sale	Prod. Group
1010 EXB	9GDH1010/005	600mm Senior, for Wide Lintels	EXB	1	5000 A
1011	9GDH1011/005	600mm for Narrow Lintels	EXB	1	5000 B
1012	9GDH1012/005	375mm Junior for Wide Lintels	EXB	1	5000 C

• Supplied as pairs for garage doors, operated by cord



Spring Loaded Animal Bolts

Boxed

Article No.	Prod. Code	No. of screws / Size mm	Screw size / Finish	Unit of Sale	Prod. Group
513 10MM	9GALVSLAB/005	10mm Shoot	10g / 4	HSG	5 5000 A
514 12MM	9GALVSLAB/010	12mm Shoot	10g / 8	HSG	5 5000

• Also suitable for use on metal containers and portable buildings • Supplied in a bag c/w fixings



Monkey Tail Bolts

Boxed

60MT 12	9JMTB/005	300 × 16	8g / 6	EXB	2	5000 A
60MT 15	9JMTB/010	375 × 16	8g / 6	EXB	2	5000
60MT 18	9JMTB/015	450 × 16	8g / 6	EXB	2	5000
60MT 24	9JMTB/020	600 × 16	8g / 6	EXB	2	5000
60MT 30	9JMTB/025	750 × 16	8g / 6	EXB	2	5000
60MT 36	9JMTB/030	900 × 16	8g / 6	EXB	2	5000

Bolts

Bow Handle Bolts



Boxed

Article No.	Prod. Code	No. of screws Size mm	Screw size / Finish	Unit of Sale	Prod. Group
60BH 12	9EXBBHB/005	300	10g/6	EXB	2 5000
60BH 18	9EXBBHB/015	450	10g/6	EXB	2 5000

• Often used with garage doors, the shoot slotting into a plate, socket or staple • Boxed bolts are individually bagged c/w fixings

Square Plates for Monkey Tail Bolts



Boxed

Article No.	Prod. Code	Size	Finish	Unit of Sale	Prod. Group
484 EG	9JMTBP/005	16	EG	50	5000

Latches

Automatic Gate Latches



Boxed

Article No.	Prod. Code	Description	No. of screws Screw size / Finish	Unit of Sale	Prod. Group
1819 EXB	9TQIAGLEXB/005	1819 Standard	8g/6	EXB	10 5000
1819 BZP	9TQIGALVAGL/010	1819 Standard	8g/6	BZP	10 5000
1819 GALV	9GALVAGL/005	1819 Standard	8g/6	Galv	10 5000
1822	9GALVAGL/010	1822 Heavy	12g/6	Galv	10 5000

Pre-packed



HQ1987/4	9HQGATEAEXB/1987	1819 Standard	8g/6	EXB	4 Bags	5001
HQ1911/4	9HQGATEAGALV/1911	1819 Standard	8g/6	BZP	4 Bags	5001
HQ1912/4	9HQGATEAGALV/1912	1822 Standard	8g/6	Galv	4 Bags	5001

• Can be locked with a padlock



Ring Gate Latches – Plain Ring

Boxed

Article No.	Prod. Code	Size	Size mm	No. of screws	Screw size /	Finish	Unit of Sale	Prod. Group
1136 5EXB	9TQIJRGL/006	5"	127	8g/12	8g/12	EXB	5	5000
1136 6EXB	9TQIJRGL/011	6"	150	8g/12	8g/12	EXB	5	5000
1136 7EXB	9TQIJRGL/016	7"	175	8g/12	8g/12	EXB	5	5000
1136 5BZP	9TQIBZPRGL/010	5"	127	8g/12	8g/12	BZP	5	5000
1136 6BZP	9TQIRGLZP/005	6"	150	8g/12	8g/12	BZP	5	5000
1136 5HSG	9GALVRGL/001	5"	127	8g/12	8g/12	Galv	5	5000
1136 6HSG	9GALVRGL/005	6"	150	8g/12	8g/12	Galv	5	5000
1136 7HSG	9GALVRGL/010	7"	175	8g/12	8g/12	Galv	5	5000

Pre-packed



HQ1909/4	9HQGATEREXB/1909	6"	150	8g/12	EXB	4 Bags	5001
HQ1989/2	9HQGATERGALV/1989	6"	150	8g/12	BZP	4 Bags	5001
HQ1990/4	9HQGATERGALV/1990	6"	150	8g/12	Galv	4 Bags	5001

• Used on garden gates



Ring Gate Latches – Twisted Ring

Boxed

1137 6EXB	9JTRGL/005	6"	150	8g/12	EXB	5	5000
137	9TQIRO/005	Ring Only		8g/12	EXB	5	5000

Pre-packed



HQ1443/2	9HQGATEBANT/1443	6"	150	8g/12	B/ANT	4 Bags	5001
----------	------------------	----	-----	-------	-------	--------	------

• Used on garden gates



Suffolk Latches

Boxed

20/2 TQEXB	9TQIJSL/010	No.2	8g/12	EXB	10	5000
20/2 BZP	9TQIBZPSL/005	No.2	8g/12	BZP	10	5000
20/2 GALV	9GALVSL/005	No.2	8g/12	Galv	10	5000
20/3 GALV	9GALVSL/010	No.3	8g/12	Galv	5	5000
20/4 GALV	9GALVSL/015	No.4	8g/12	Galv	5	5000

Pre-packed



HQ1905/4	9HQSUFFOLKEXB/1905	No.2	8g/12	EXB	4 Bags	5001
HQ1907/4	9HQSUFFOLKGALV/1907	No.2	8g/12	BZP	4 Bags	5001
HQ1906/4	9HQSUFFOLKEXB/1906	No.3	8g/12	EXB	4 Bags	5001

• For use on garden gates and timber brace doors, where rim fitting is required



Latches

Black Antique, Locking Thumb Latch

Boxed



Article No.	Prod. Code	Finish	Unit of Sale	Prod. Group
KX917	9KXANTIQUE/917	B/ANT	1	5000 A

Pre-packed

HQ1441/2	9HQTHUMBANT/1441	B/ANT	2 Bags	5001
----------	------------------	-------	--------	------

• Locked by inserting pin into a hole, which ensures the latch cannot be raised



Black Antique, Door Studs

Boxed

KX933	9KXANTIQUE/933	B/ANT	50	5000
-------	----------------	-------	----	------

• For decorative purposes

Cabin Hooks

28 Wire Pattern

Boxed



Article No.	Prod. Code	Size	No. of screws / Size mm	Screw size /	Finish	Unit of Sale	Prod. Group
28 4TQ	9TQIJCH/006	4"	100	6g/8	EXB	25	5000
28 6TQ	9TQIJCH/011	6"	150	6g/8	EXB	25	5000
28 8TQ	9TQIJCH/016	8"	200	6g/8	EXB	25	5000
28 4BZP	9TQIBZPCH/005	4"	100	6g/8	BZP	25	5000
28 6BZP	9TQIBZPCH/010	6"	150	6g/8	BZP	25	5000
28 8BZP	9TQIBZPCH/015	8"	200	6g/8	BZP	25	5000

• Steel wire construction • Used to restrain door and gate movement



Black Antique

Boxed

KX958	9KXANTIQUE/958	100mm	B/ANT	10	5000
KX959	9KXANTIQUE/959	150mm	B/ANT	10	5000

Pre-packed



HQ1507/4	9HQHOOKBANT/1507	100mm	B/ANT	4 Bags	5001
HQ1509/4	9HQHOOKBANT/1509	150mm	B/ANT	4 B	5001

• Malleable Castings, with two traditional rings



1637 Malleable

Boxed

Article No.	Prod. Code	Size	No. of screws Size mm	Screw size /	Finish	Unit of Sale	Prod. Group
1637/3EXB	9JCHK/005	3"	75	8g / 4	EXB	10	5000
1637/4EXB	9JCHK/010	4"	100	8g / 4	EXB	10	5000
1637/6EXB	9JCHK/015	6"	150	8g / 4	EXB	10	5000
1637/8EXB	9JCHK/020	8"	200	8g / 4	EXB	10	5000
1637/10EXB	9JCHK/025	10"	250	8g / 4	EXB	10	5000
1637/12EXB	9JCHK/030	12"	300	8g / 4	EXB	10	5000
1637/4GALV	9GALVCHK/005	4"	100	8g / 4	Galv	10	5000
1637/6GALV	9GALVCHK/010	6"	150	8g / 4	Galv	10	5000
1637/8GALV	9GALVCHK/015	8"	200	8g / 4	Galv	10	5000
1637/10GALV	9GALVCHK/020	10"	250	8g / 4	Galv	10	5000
1637/12GALV	9GALVCHK/025	12"	300	8g / 4	Galv	10	5000

• Cast malleable iron • Used to restrain door and gate movement

Pre-packed



HQ1899/4	9HQHOOKEXB/1899	4"	100	8g / 4	EXB	4 Bags	5001
HQ1901/4	9HQHOOKEXB/1901	6"	150	8g / 4	EXB	4 Bags	5001
HQ1903/2	9HQHOOKEXB/1903	8"	200	8g / 4	EXB	4 Bags	5001



Brass

Boxed

Article No.	Prod. Code	Size	Finish	Unit of Sale	Prod. Group
KX441	9KXVIC/441	75mm	PLB	10	5000
KX442	9KXVIC/442	100mm	PLB	10	5000
KX443	9KXVIC/443	150mm	PLB	5	5000
KX444	9KXVIC/444	200mm	PLB	5	5000

Pre-packed



HQ1295/4	9HQHOOKVIC/1295	75mm	PLB	4 Cards	5001
HQ1297/4	9HQHOOKVIC/1297	100mm	PLB	4 Cards	5001
HQ1299/4	9HQHOOKVIC/1299	150mm	PLB	4 Cards	5001
HQ1301/4	9HQHOOKVIC/1301	200mm	PLB	4 Cards	5001
HQ1635/4	9HQHOOKCP/1635	100mm	CP	4 Cards	5001
HQ1637/4	9HQHOOKCP/1637	150mm	CP	4 Cards	5001
HQ1639/2	9HQHOOKCP/1639	200mm	CP	2 Cards	5001

• Solid and durable hooks with quality cast keeps • Laquered to resist weathering and tarnishing

Cabin Hooks

Brass, Heavy

Boxed



Article No.	Prod. Code	Size	Finish	Unit of Sale	Prod. Group
KX445	9KXVIC/445	152mm	PLB	10	5000
KX446	9KXVIC/446	203mm	PLB	10	5000
KX447	9KXVIC/447	254mm	PLB	5	5000
KX448	9KXVIC/448	305mm	PLB	5	5000

• Solid and durable, traditional quality hooks with cast keeps • Laquered to resist weathering and tarnishing

Hasp & Staples

617 Safety Hasp & Staples

Boxed



Article No.	Prod. Code	Size	No. of screws	Screw size / Size mm	Finish	Unit of Sale	Prod. Group
617EXB3	9TQIEXBSHS/005	3"	75	8g/6	EXB	10	5000
617EXB4.5	9TQIEXBSHS/010	4.1/2"	115	8g/6	EXB	10	5000
617EXB6	9TQIEXBSHS/015	6"	150	8g/6	EXB	10	5000
617BZP 3	9TQIBZPSHS/005	3"	75	8g/6	BZP	10	5000
617BZP 4.5	9TQIBZPSHS/010	4.1/2"	115	8g/6	BZP	10	5000
617BZP 6	9TQIBZPSHS/015	6"	150	8g/6	BZP	10	5000
617GALV 3	9BZSHS/005	3"	75	8g/6	HSG	10	5000
617GALV4.5	9BZSHS/010	4.1/2"	115	8g/6	HSG	10	5000
617GALV6	9BZSHS/015	6"	150	8g/6	HSG	10	5000

Pre-packed



HQ1887/4	9HQHASPSEXB/1887	3"	75	8g/6	EXB	4 Bags	5001
HQ1889/4	9HQHASPSEXB/1889	4.1/2"	115	8g/6	EXB	4 Bags	5001
HQ1891/4	9HQHASPSEXB/1891	6"	150	8g/6	EXB	4 Bags	5001
HQ1893/4	9HQHASPSPGALV/1893	3"	75	8g/6	BZP	4 Bags	5001
HQ1895/4	9HQHASPSPGALV/1895	4.1/2"	115	8g/6	BZP	4 Bags	5001
HQ1897/4	9HQHASPSPGALV/1897	6"	150	8g/6	BZP	4 Bags	5001

• Screwheads are covered when the hasp is closed, for additional security

618 Heavy Safety Hasp & Staples

Boxed



618EXB 7	9HHSEXB/005	7"	175	12g/8	EXB	5	5000
618GALV 7	9HHSGALV/010	7"	175	12g/8	HSG	5	5000

Pre-packed



HQ1892/4	9HQHASPSEXB/1892	6"	150MM	12g/8	Black	4 Bags	5001
HQ1898/4	9HQHASPSPGALV/1898	7"	175MM	12g/8	Galv	4 Bags	5001

• A heavier duty version of the 617 Hasp & Staple



149 Safety Hasp & Staples

Boxed

Article No.	Prod. Code	Size	No. of screws Size mm	Screw size / No. of screws	Finish	Unit of Sale	Prod. Group
149M 8EXB	9HHSEXB/020	8" Med	200	10g/8	EXB	5	5000
149M 8GALV	9HHSGALV/030	8" Med	200	10g/8	HSG	5	5000
149H 10EXB	9HHSEXB/025	10" Hvy	250	10g/8	EXB	5	5000
149H 8GALV	9HHSGALV/033	8" Hvy	200	10g/8	HSG	5	5000
149H 10GALV	9HHSGALV/035	10" Hvy	250	10g/8	HSG	5	5000

• A heavier duty Hasp & Staple • Medium weight requires 8mm diameter coach bolts • Heavy weight requires 12mm diameter coach bolts



610 Wire Hasp & Staples

Boxed

610EXB3	9TQIEXBWHS/005	3"	75	6g/5	EXB	10	5000
610EXB4	9TQIEXBWHS/010	4"	100	6g/5	EXB	10	5000
610EXB5	9TQIEXBWHS/015	5"	125	6g/7	EXB	10	5000
610EXB6	9TQIEXBWHS/020	6"	150	6g/8	EXB	10	5000

Pre-packed



HQ1883/4	9HQHASPWEXB/1883	3"	75	6g/5	EXB	4 Bags	5001
HQ1885/4	9HQHASPWEXB/1885	4"	100	6g/5	EXB	4 Bags	5001

• Often used on small animal hutches



608 Light Wire Hasp & Staples

Boxed

608 3EXB	9TQIEXBWHS/001	3"	75	6g/5	EXB	50	5000
608 3BZP	9TQIBZPWHS/001	3"	75	6g/5	BZP	50	5000

• A lighter version of the 610 Hasp & Staple



146 Vertical Hasp & Staples

Boxed

146EXB	9VHS/005	6"	150	12g/8	EXB	5	5000
--------	----------	----	-----	-------	-----	---	------

• For use where there is a horizontal restriction • Use 12mm diameter coach bolts

Hasp & Staples

147 Locking Bars



Boxed

Article No.	Prod. Code	Size	No. of screws Size mm	Screw size / Finish	Unit of Sale	Prod. Group
147/8EXB	9SLB/005	8"	200	12g/8	EXB	5 5000
147/8GALV	9SLB/025	8"	200	12g/8	HSG	5 5000

• A swivelling locking bar with the screw plate hidden • Widely specified by local authorities

Pre-packed



HQ1882/2	9HQHASPSSLBEXB/1882	10"	250	12g/8	Black	5001
----------	---------------------	-----	-----	-------	-------	------

930 Padlock Protection Bars



Boxed

Article No.	Prod. Code	Size	Finish	Unit of Sale	Prod. Group
930EXB LH	9TQIEXBPPB/005	Left Hand	EXB	1	5000
930EXB RH	9TQIEXBPPB/010	Right Hand	EXB	1	5000

• Available in left or right hand • Protects the padlock on a Hasp & Staple from attack by hammer

Agricultural Ironmongery

Adjustable Field Gate Sets



Boxed

OJ147796	9GALVAFGS/015	600mm	HSG	1	5000
133 HSG	9GALVAFGSP/005	600mm on 100 x 100 Plates	HSG	1	5000

• Suitable for 3" gates

Field Gate Catch and Cranked Peg c/w Fittings



Boxed

4200 175MM	9GALVFGC/005	175mm	HSG	1	5000
------------	--------------	-------	-----	---	------



Self Locking Gate Catch

Boxed

Article No.	Prod. Code	Size	Finish	Unit of Sale	Prod. Group
500 HSG	9GALVFGC/050	175 x 115	HSG	1	5000



Staple on Plate

Boxed

512 HSG	9GALVFGC/075	50mm Square Plate	HSG	10	5000
---------	--------------	-------------------	-----	----	------



Hook on Plate

Boxed

511 HSG	9GALVFGC/080	50mm Square Plate	HSG	10	5000
153 HSG	9GALVGHHK/005	100mm Square Plate	HSG	5	5000



Ring on Plate

Boxed

517 HSG	9GALVFGC/085	50mm Square Plate	HSG	10	5000
---------	--------------	-------------------	-----	----	------

Agricultural Ironmongery

Adjustable Gate Eyes



Boxed

Article No.	Prod. Code	Size	Unit of Sale Finish	Prod. Group
165 150MM	9GALVFGC/105	19mm/150mm	BZP 5	5000
165 200MM	9GALVFGC/110	19mm/200mm	BZP 5	5000
165 250MM	9GALVFGC/115	19mm/250mm	BZP 5	5000

• 3/4" shank, c/w 2 nuts

Spring Field Gate Sets



Boxed

Article No.	Prod. Code	Description	Unit of Sale Finish	Prod. Group
OJ026831	9GALVSFGS/005	Complete Set	HSG 1	5000 A

Throw Over Gate Loops



Boxed

Article No.	Prod. Code	Size	Unit of Sale Finish	Prod. Group
156/M	9GALVTGL/010	350 x 50 x 6	HSG 2	5000 A

• Suitable for pairs of gates

Heavy Kick Over Stable Latch



Boxed

Article No.	Prod. Code	Size	Unit of Sale Finish	Prod. Group
4203GALV	9KOSL/005	225mm	HSG 1	5000

• Used for stable doors or other applications where there needs to be a hands-free shutting method



Cleat Hooks

Boxed

Article No.	Prod. Code	Size	No. of screws / Size mm	Screw size /	Finish	Unit of Sale	Prod. Group
150/4GALV	9GALVCCCHK/003	4"	100	8g/2	Galv	25	5000
150/5GALV	9GALVCCCHK/005	12	125	8g/2	Galv	10	5000

Pre-packed



HQ1993/4	9HQHOOKGALV/1993	127mm	8g/2	BZP	4 Bags of 2	5001
----------	------------------	-------	------	-----	-------------	------

Pulleys

Boxed



Article No.	Prod. Code	Description	No. of screws / Size	Screw size /	Finish	Unit of Sale	Prod. Group	Availability	Category
202/S	9TQIPULLEY/005	44mm 202/S Nylon Wheel Sash Pulley	8g/2	BZP	10	5000	<input checked="" type="checkbox"/>	A	
HQ1935/2	9HQSASHBZ/1935	44mm 202/S Nylon Wheel Sash Pulley	8g/2	BZP	4 Bags	5001	<input type="checkbox"/>		
202/BS	9TQIPULLEY/010	44mm 202/BS Nylon Wheel Sash Pulley	8g/2	B/F	10	5000	<input checked="" type="checkbox"/>		
HQ1937/2	9HQSASHBR/1937	44mm 202/BS Nylon Wheel Sash Pulley	8g/2	B/F	2 Bags	5001	<input type="checkbox"/>		
41/N EXB	9PULLEY/010	41/N 1.3/4" Single Screw Pulley			EXB	10	5000	<input checked="" type="checkbox"/>	B
31/N	9PULLEY/005	31/N 1.1/2" Single Side Pulley			EXB	10	5000	<input checked="" type="checkbox"/>	C
261/N	9PULLEY/060	261/N 1.1/2" Single Line Pulley			EXB	10	5000	<input checked="" type="checkbox"/>	D
40/42N	9PULLEY/020	40-42N 13/4" Double Screw Pulley			EXB	10	5000	<input checked="" type="checkbox"/>	E
264/N	9PULLEY/070	264/N 1.1/2" Upright Pulley			EXB	10	5000	<input checked="" type="checkbox"/>	
260/N	9PULLEY/050	260/N 1.1/4" Clothes Line Pulley			EXB	10	5000	<input checked="" type="checkbox"/>	F
HQ1991/4	9HPULLEY/1991	260/N 1.1/4" Clothes Line Pulley			EXB	10	5001	<input type="checkbox"/>	



A



B



C



D



E



F



Gate/Door Springs

UNIFIX[®]

Article No.	Prod. Code	Size	No. of screws Size mm	Screw size / Screw	Finish	Unit of Sale	Prod. Group	
774-8	9TQIEXBDS/005	8"	200	8g / 4	EXB	10	5000	<input checked="" type="checkbox"/>
774-10	9TQIEXBDS/010	10"	250	8g / 4	EXB	10	5000	<input checked="" type="checkbox"/>
774 8BZ	9TQIBZDS/005	8"	200	8g / 4	BZP	10	5000	<input checked="" type="checkbox"/>
HQ1913/4	9HQSPRINGEXB/1913	8"	200	8g / 4	EXB	4 Bags	5001	<input type="checkbox"/>
HQ1915/4	9HQSPRINGEXB/1915	10"	250	8g / 4	EXB	4 Bags	5001	<input type="checkbox"/>

• A self closing spring, suitable for lightweight gates and doors



Door/Wardrobe Hooks

UNION
ASSA ABLOY

Article No.	Prod. Code	Description	Size	Finish	Prod. Group	
8710AS	9ALUHCH/005	J-8710 Aluminium Hat & Coat Hook	110×18×65mm	AS	5074	<input checked="" type="checkbox"/>

• Material: Aluminium with black plastic moulded end caps • Return to door • Sprung lever handle mechanism • Handle Length: 100mm



Door/Wardrobe Hooks



Article No.	Prod. Code	Description	Finish	Unit of Sale	Prod. Group		
KX375	9KXALUM/375	125mm Alum Hat & Coat Hook	SAA	50	5000	<input checked="" type="checkbox"/>	A
HQ1089/4	9HQHOOKAA/1089	125mm Alum Hat & Coat Hook	SAA	4 Bags of 2	5001	<input type="checkbox"/>	
KX475	9KXVIC/475	125mm Brass Hat & Coat Hook	PLB	10	5000	<input checked="" type="checkbox"/>	B
HQ1289/4	9HQHOOKVIC/1289	125mm Brass Hat & Coat Hook	PLB	4 Bags of 2	5001	<input type="checkbox"/>	
HQ1633/4	9HQHOOKCP/1633	125mm Brass Hat & Coat Hook	PC	4 Bags of 2	5001	<input type="checkbox"/>	
KX474	9KXVIC/474	150mm Brass H/Duty Hat & Coat Hook	PLB	10	5000	<input checked="" type="checkbox"/>	C
KX975	9KXANTIQUE/975	150mm Blk Antique Hat & Coat Hook	B/ANT	5	5000	<input checked="" type="checkbox"/>	D
HQ1485/4	9HQHOOKBANT/1485	150mm Blk Antique Hat & Coat Hook	B/ANT	4 Bags	5001	<input type="checkbox"/>	
KX376	9KXALUM/376	50mm Alum Wardrobe Hook	SAA	25	5000	<input checked="" type="checkbox"/>	E
HQ1091/4	9HQHOOKAA/1091	50mm Alum Wardrobe Hook	SAA	4 Bags of 2	5001	<input type="checkbox"/>	
HQ1291/4	9HQHOOKVIC/1291	50mm Brass Wardrobe Hook	PLB	4 Bags of 2	5001	<input checked="" type="checkbox"/>	F
HQ1691/4	9HQHOOKCP/1691	50mm Brass Wardrobe Hook	PC	4 Bags	5001	<input type="checkbox"/>	
KX476	9KXVIC/476	50mm Brass Wardrobe Hook	PLB	25	5000	<input type="checkbox"/>	
KX477	9KXVIC/477	50mm Brass Double Wardrobe Hook	PLB	25	5000	<input checked="" type="checkbox"/>	G
HQ1293/4	9HQHOOKVIC/1293	50mm Brass Double Wardrobe Hook	PLB	4 Bags	5001	<input type="checkbox"/>	

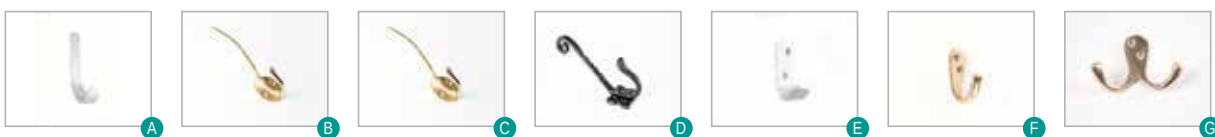

Handrail Brackets



Article No.	Prod. Code	Description	No. of screws	Screw size / Size	Finish	Unit of Sale	Prod. Group		
236 2.5ZP	9TQIBZHB/006	236 Handrail Brackets 2.1/2"		10g/5	BZP	10	5000	<input checked="" type="checkbox"/>	A
236 3.0ZP	9TQIBZHB/011	236 Handrail Brackets 3"		10g/5	BZP	10	5000	<input checked="" type="checkbox"/>	
236 2.5W	9TQIWHHB/006	236 Handrail Brackets 2.1/2"		10g/5	EXW	10	5000	<input checked="" type="checkbox"/>	
236 3.0W	9TQIWHHB/011	236 Handrail Brackets 3"		10g/5	EXW	10	5000	<input checked="" type="checkbox"/>	
HQ1827/4	9QHHRBZ/1827	236 Handrail Brackets 2.1/2"		10g/5	BZP	4 Bags of 2	5001	<input type="checkbox"/>	
HQ1829/4	9QHHRBEXW/1829	236 Handrail Brackets 2.1/2"		10g/5	EXW	4 Bags of 2	5001	<input type="checkbox"/>	
KX373	9KXALUM/373	Alum Hvy Duty Handrail Bracket 2.1/2"			SAA	5	5000	<input checked="" type="checkbox"/>	B
HQ1113/4	9QHHRBAA/1113	Alum Hvy Duty Handrail Bracket 2.1/2"			SAA	4 Bags of 2	5001	<input type="checkbox"/>	
KX472	9KXVIC/472	Brass Handrail Bracket 2.1/2"			PLB	5	5000	<input checked="" type="checkbox"/>	C
KX572	9KXVIC/572	Brass Handrail Bracket 2.1/2"			CP	5	5000	<input checked="" type="checkbox"/>	
HQ1303/4	9QHHRVIC/1303	Brass Handrail Bracket 2.1/2"			PLB	4 Bags	5000	<input type="checkbox"/>	
HQ1689/4	9QHHRBCP/1689	Brass Handrail Bracket 2.1/2"			CP	4 Bags 5	5000	<input type="checkbox"/>	



Plates & Brackets

UNIFIX®



319 Corner Braces

Article No.	Prod. Code	Size	No. of screws	Screw size / Size	Finish	Unit of Sale	Prod. Group	
319 1.0	9TQIZPCOB/005	1"	25	6g/2	ZYP	50	5000	<input checked="" type="checkbox"/>
319 1.5	9TQIZPCOB/010	1.1/2"	38	5g/4	ZYP	50	5000	<input checked="" type="checkbox"/>
319 2.0	9TQIZPCOB/015	2"	50	5g/4	ZYP	50	5000	<input checked="" type="checkbox"/>
319 2.5	9TQIZPCOB/020	2.1/2"	65	5g/4	ZYP	50	5000	<input checked="" type="checkbox"/>
319 3.0	9TQIZPCOB/025	3"	75	6g/6	ZYP	50	5000	<input checked="" type="checkbox"/>
319 4.0	9TQIZPCOB/030	4"	100	6g/6	ZYP	25	5000	<input checked="" type="checkbox"/>
319 5.0	9TQIZPCOB/035	5"	125	6g/6	ZYP	25	5000	<input checked="" type="checkbox"/>
319 6.0	9TQIZPCOB/040	6"	150	6g/6	ZYP	25	5000	<input checked="" type="checkbox"/>
HQ1939/4	9HQCORNERBZP/1939	1"	25	6g/2	ZYP	4 Bags of 2	5001	<input type="checkbox"/>
HQ1941/4	9HQCORNERBZP/1941	1.1/2"	38	5g/4	ZYP	4 Bags of 2	5001	<input type="checkbox"/>
HQ1943/4	9HQCORNERBZP/1943	2"	50	5g/4	ZYP	4 Bags of 2	5001	<input type="checkbox"/>
HQ1945/4	9HQCORNERBZP/1945	2.1/2"	65	5g/4	ZYP	4 Bags of 2	5001	<input type="checkbox"/>
HQ1947/4	9HQCORNERBZP/1947	3"	75	6g/6	ZYP	4 Bags of 2	5001	<input type="checkbox"/>



324 Corner Plates

UNIFIX®

324 2.0	9TQIZPCOP/005	2"	50	5g/4	ZYP	50	5000	<input checked="" type="checkbox"/>
324 2.5	9TQIZPCOP/010	2.1/2"	65	7g/4	ZYP	50	5000	<input checked="" type="checkbox"/>
324 3.0	9TQIZPCOP/015	3"	75	8g/4	ZYP	50	5000	<input checked="" type="checkbox"/>
324 4.0	9TQIZPCOP/020	4"	100	8g/6	ZYP	25	5000	<input checked="" type="checkbox"/>
324 5.0	9TQIZPCOP/025	5"	125	8g/6	ZYP	25	5000	<input checked="" type="checkbox"/>
324 6.0	9TQIZPCOP/030	6"	150	8g/6	ZYP	25	5000	<input checked="" type="checkbox"/>
HQ1949/4	9HQCORNERPZP/1949	2"	50	5g/4	ZYP	4 Bags of 2	5001	<input type="checkbox"/>
HQ1951/4	9HQCORNERPZP/1951	2.1/2"	65	7g/4	ZYP	4 Bags of 2	5001	<input type="checkbox"/>



325 Mending Plates

UNIFIX®

325 3.0	9TQIZPMEP/005	3"	75	7g/4	ZYP	50	5000	<input checked="" type="checkbox"/>
325 4.0	9TQIZPMEP/010	4"	100	7g/4	ZYP	50	5000	<input checked="" type="checkbox"/>
325 5.0	9TQIZPMEP/015	5"	125	8g/4	ZYP	25	5000	<input checked="" type="checkbox"/>
325 6.0	9TQIZPMEP/020	6"	150	8g/4	ZYP	25	5000	<input checked="" type="checkbox"/>
HQ1957/4	9HQMENDPZP/1957	3"	75	7g/4	ZYP	4 Bags of 2	5001	<input type="checkbox"/>
HQ1959/4	9HQMENDPZP/1959	4"	100	7g/4	ZYP	4 Bags of 2	5001	<input type="checkbox"/>



318 Tee Plates



Article No.	Prod. Code	Size	No. of screws	Screw size / Size	Finish	Unit of Sale	Prod. Group	
318 3.0	9TQIZPTEEP/005	3"	75	8g/5	ZYP	25	5000	<input checked="" type="checkbox"/>
318 4.0	9TQIZPTEEP/010	4"	100	8g/5	ZYP	25	5000	<input checked="" type="checkbox"/>



326 Connecting Brackets



326	9TQIZPCONB/005	2"	50	6g/2	BZP	50	5000	<input checked="" type="checkbox"/>
-----	----------------	----	----	------	-----	----	------	-------------------------------------



322 Flange Corner Brackets – 90°



322 50BZP	9TQIZPFCB/005	2"	50	6g/4	BZP	50	5000	<input checked="" type="checkbox"/>
HQ2211/4	9HQBRACKET/2211	2"			BZP	4 Bags of 2	5001	<input type="checkbox"/>



323 Flat Corner Brackets



323 83BZP	9TQIZPFCB/010	83mm	6g/4	BZP	20	5000	<input checked="" type="checkbox"/>
HQ2213/4	9HQBRACKET/2213			BZP	2	5001	<input type="checkbox"/>



Table Stretcher Plates



315	9TQIZPTSP/005	1.1/2"	40	8g/2	ZYP	100	5000	<input checked="" type="checkbox"/>
HQ1963/4	9HQSTRECHBZP/1963	1.1/2"	40	8g/2	ZYP	4 Bags of 2	5001	<input type="checkbox"/>



Z Connecting Brackets – Cranked



328	9TQIZPZCONB/010	28mm	6g/2	BZP	50	5000	<input checked="" type="checkbox"/>
-----	-----------------	------	------	-----	----	------	-------------------------------------

Plates & Brackets

Glass Plates



Article No.	Prod. Code	No. of screws / Size	Screw size / Size	Finish	Unit of Sale	Prod. Group	
HQ2109/4	9HQGLASSP/2109	Plain 1"	6g/2	PLB	4 Cards of 2	5001	<input type="checkbox"/>
HQ2111/4	9HQGLASSP/2111	Plain 1.1/2"	6g/2	PLB	4 Cards of 2	5001	<input type="checkbox"/>
HQ2113/4	9HQGLASSP/2113	Slotted 1.1/4"	6g/2	PLB	4 Cards of 2	5001	<input type="checkbox"/>
HQ2115/4	9HQGLASSP/2115	Slotted 1.1/2"	6g/2	PLB	4 Cards of 2	5001	<input type="checkbox"/>

Ridge Plates



331	9TQIRP/005	331 Ridge Plate ZYP	6g/2	ZYP	100	5000	<input checked="" type="checkbox"/>
-----	------------	---------------------	------	-----	-----	------	-------------------------------------

Bookcase Strip

Strip



Article No.	Prod. Code	Description	Finish	Unit of Sale	Prod. Group	
BSRN	9TQIBCS/005	Raised 1800mm Lengths	NP	10	5000	<input checked="" type="checkbox"/>
BSRE	9TQIBCS/010	Raised 1800mm Lengths	EB	10	5000	<input checked="" type="checkbox"/>
BSRI	9TQIBCS/015	Raised 1800mm Lengths	IBMA	10	5000	<input checked="" type="checkbox"/>
BSFN	9TQIBCS/020	Flat 1800mm Lengths	NP	10	5000	<input checked="" type="checkbox"/>
BSFE	9TQIBCS/025	Flat 1800mm Lengths	EB	10	5000	<input checked="" type="checkbox"/>
BSFI	9TQIBCS/030	Flat 1800mm Lengths	IBMA	10	5000	<input checked="" type="checkbox"/>

Studs



SRSN	9TQIBCSS/005	Studs for Raised Bookcase Strip	NP	50	5000	<input checked="" type="checkbox"/>
SRSE	9TQIBCSS/010	Studs for Raised Bookcase Strip	EB	50	5000	<input checked="" type="checkbox"/>
SRSI	9TQIBCSS/015	Studs for Raised Bookcase Strip	IBMA	50	5000	<input checked="" type="checkbox"/>
SFSN	9TQIBCSS/020	Studs for Flat Bookcase Strip	NP	50	5000	<input checked="" type="checkbox"/>
SFSE	9TQIBCSS/025	Studs for Flat Bookcase Strip	EB	50	5000	<input checked="" type="checkbox"/>
SFSI	9TQIBCSS/030	Studs for Flat Bookcase Strip	IBMA	50	5000	<input checked="" type="checkbox"/>



Modesty Blocks



Article No.	Prod. Code	Description	Finish	Unit of Sale	Prod. Group
HQ2097/4	9HQBLOCK/2097	Modesty Block – Pack 25	White	4 Cards	5001



Toilet Roll Holders

KX395	9KXALUM/395	Alum Toilet Roll Holder	SAA	10	5000
-------	-------------	-------------------------	-----	----	------



Cupboard/Turn Buttons

Article No.	Prod. Code	Size	No. of screws	Screw size / Size mm	Finish	Unit of Sale	Prod. Group
56 42BLK	9TQIBLKT/005	1.1/2"	42	10g/1	EXB	100	5000
56 38BZP	9TQIBZPT/005	1.1/2"	38	10g/1	BZP	100	5000
55 50EXB	9TQIJCB/005	2"	50	10g/1	EXB	100	5000
57EXB 2.50	9TQIJCB/010	2.1/2"	65	10g/1	EXB	100	5000
55	9TQIZPCB/005	2"	50	10g/1	BZP	50	5000
57BZP 2.50	9TQIZPCB/010	2.1/2"	65	10g/1	BZP	100	5000

MAP Products

Louvre Flush Vents

Product Codes Begin **9MAPVENT** Product Group **5026**



Article No.	Article No.	Finish	Box Qty.	Unobstructive	Easy Surface Mounting	Removable Fly Screen	Integral Fly Screen	Venting Gas Appliances	Internal or Exterior Use	Low Profile Design	Concealed Screws	
913 02	229 x 75	White	10	●	●	●	●	●	●	●	●	A
916 02	9" x 152	White	10	●	●	●	●	●	●	●	●	A

Louvre Surface Vents

922 02	150 x 75	White	10	●	●	●	●	●	●	●	●	B
923 02	229 x 75	White	10	●	●	●	●	●	●	●	●	B
926 02	229 x 152	White	10	●	●	●	●	●	●	●	●	B
929 02	229 x 229	White	10	●	●	●	●	●	●	●	●	B
953 31	229 x 75	SAA	10	●	●	●	●	●	●	●	●	C
956 31	229 x 152	SAA	10	●	●	●	●	●	●	●	●	C
959 31	229 x 229	SAA	10	●	●	●	●	●	●	●	●	C
966 33	229 x 152	Gold	10	●	●	●	●	●	●	●	●	D



Adjustable Surface Vents

902 02	150 x 75	White	10	●	●	●	●	●	●	●	●	E
903 02	229 x 75	White	10	●	●	●	●	●	●	●	●	E
906 02	229 x 6"	White	10	●	●	●	●	●	●	●	●	E
909 02	229 x 9"	White	10	●	●	●	●	●	●	●	●	E
933 31	229 x 75	SAA	10	●	●	●	●	●	●	●	●	F
939 31	229 x 9"	SAA	10	●	●	●	●	●	●	●	●	F



Round Soffit Vents

901 02	70 mm	White	1 x 10	●	●	●	●	●	●	●	●	G
M901 02	70 mm	White	1 x 50	●	●	●	●	●	●	●	●	G

• Easy push fit • No fixings required

Slot/Trickle Vents

971 02	375 mm	White	5	●	●	●	●	●	●	●	●	H
971 04	375 mm	Brown	5	●	●	●	●	●	●	●	●	H

• Meets building regulations • Reduces the problem of stale air • Unobstructive draught-free



Castors



Product Codes Begin **9MAPCASTOR** Product Group **5026**

Article No.	Description	Finish	Box Qty.
24407	Castors with 32mm Plate	Black Wheel	6 × 2

• A set of user-friendly and durable single wheel castors, plate fitting

Lengths of Tube & Accessories



CP



BP

Tube

Product Codes Begin **9CPTUBE** Product Group **5084**

Article No.	Size	Finish	Box Qty.
HQ3851H	0.91m (3ft) × 19mm	CP	10
HQ3852H	1.20m (4ft) × 19mm	CP	5
HQ3854H	1.83m (6ft) × 19mm	CP	5
HQ3855H	2.44m (8ft) × 19mm	CP	5
HQ3857H	0.91m (3ft) × 25mm	CP	10
HQ3858H	1.20m (4ft) × 25mm	CP	10

HQ3860H	1.83m (6ft) × 25mm	CP	5
HQ3861H	2.44m (8ft) × 25mm	CP	5



A



B



C

Accessories



Product Codes Begin **9CPTUBE/9BPTUBE** Product Group **5084**

Article No.	Description	Finish	Box Qty.
HQ222SP	End Sockets 19mm	CP	5
HQ224SP	End Sockets 25mm	CP	5
HQ570SP	End Brackets 19mm	CP	5
HQ3490SP	End Brackets 25mm	CP	5
HQ572SP	Centre Brackets 19mm	CP	5
HQ3492SP	Centre Brackets 25mm	CP	5

Slik Sliding Door Gear

Product Codes Begin **9SLIK** Product Group **5085**

Article No.	Description	Box Qty.
08SL0011219	Slik Wardrobe Gear No.1 1219mm	1
08SL0011524	Slik Wardrobe Gear No.1 1524mm	1
08SL0011828	Slik Wardrobe Gear No.1 1828mm	1
08SL0021828	Slik Wardrobe Gear No.2 1828mm	1

- Ideal for built-in storage space and wardrobes. Doors are allowed to bypass each other smoothly carried by nylon wheels on strong aluminium tracks
- Total weight of all doors should not exceed 40kg (88lbs). Minimum door thickness 16mm (5/8"). Maximum door width 1.22m (4'0"). Maximum door height 2.19m (7'6") • For fitting two or more doors to bypass each other. 914mm (3'0"), 1,219mm (4'0"), 1,524mm (5'0") & 1,828mm (6'0") kits supplied with fittings for 2 doors, 2,438mm (8'0") kit supplied with fittings for 3 doors

08SL0041219	Slik Cupboard Door Gear 1219mm	1
08SL0041524	Slik Cupboard Door Gear 1524mm	1
08SL0041828	Slik Cupboard Door Gear 1828mm	1

08SL0030762	Slik Ballrace Door Gear 762mm	1
08SL0030914	Slik Ballrace Door Gear 914mm	1

- The Ballrace system can be used for converting an existing internal hinged door to a sliding door or fitting an internal door to an existing opening
- Minimum door thickness 22mm (7/8") and Maximum door weight 35kg (77lbs) • Extra smooth running 'Ball Race action'

08SL0050914	Slik Double Wheel Type Door Gear 914mm	1
-------------	--	---

- The Double Wheel Type system can be used for converting an existing internal hinged door to a sliding door or fitting an internal door to an existing opening • Minimum door thickness 22mm (7/8"). Maximum door weight 30kg (66lbs) • Smooth running, robust and adaptable door system featuring twin nylon wheels riveted to tough steel trolleys, which run in a hard wearing aluminium track

08SL0061219	Slik Folding Door Gear 1219mm	1
08SL0061524	Slik Folding Door Gear 1524mm	1
08SL0061828	Slik Folding Door Gear 1828mm	1

- For fitting doors to fold either side of an opening • Maximum weight per door is 15kg (33lbs) each. Maximum system weight 60kg (132lbs). Doors from 1" (25mm) to 1.3/8" (34mm) thick • A sturdy design to allow doors to fold either side of an opening leaving the floor clear for easy access

9SLIKMERCH/005	Slik V3 Small Merch Only	1
----------------	--------------------------	---

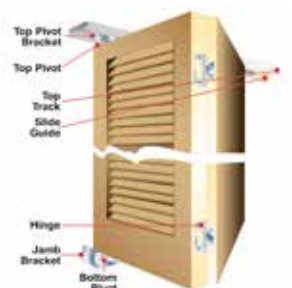
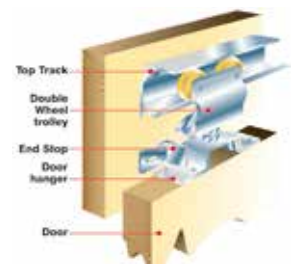
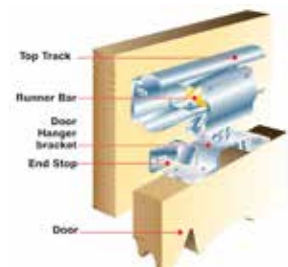
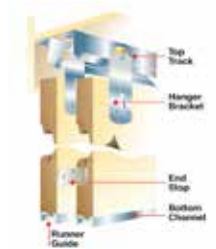



BALL RACE SLIDING DOOR GEAR

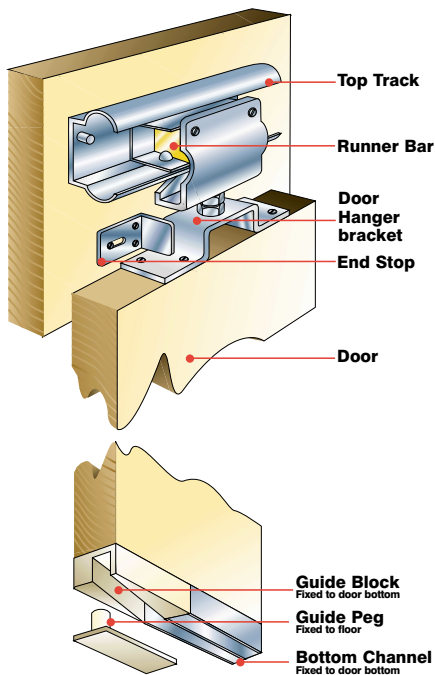

DOUBLE WHEEL TYPE SLIDING DOOR GEAR

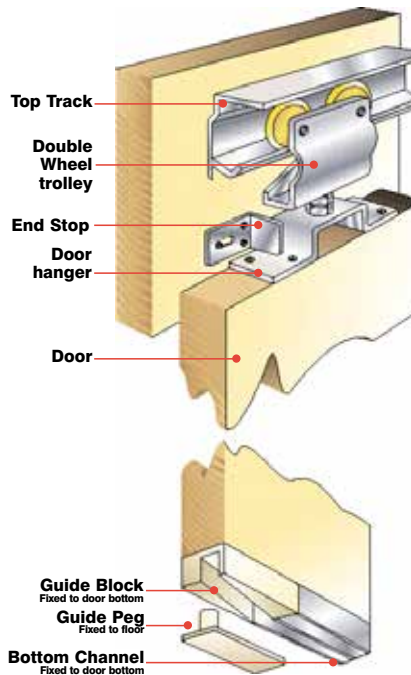

USE BALL RACE FOR

- Highly durable - Smooth running action
- Converting an existing internal hinged door to a sliding door.
- Fitting an internal sliding door to an existing opening.
- Doors up to 2'6" (762mm) use 2'6" kit.
- Doors up to 3'0" (914mm) use 3'0" kit.
- Max. door weight 35kg (77lbs) Min. door thickness 22mm (7/8").

The Ball Race system should not be cut down to lengths in between the above measurements. If your door opening is smaller than 3'0" but larger than 2'6" buy the 3'0" kit and position the endstops included in the kit to allow the door to open/close in the correct position.

KIT CONTAINS

1 top track assembly incl. runner bar, 2 hangers, 1 guide peg, 2 guide blocks, 2 end stops, 1 bottom channel, fixing screws, nuts and bolts.

TOOLS REQUIRED

Screwdriver, 10mm spanner, Hacksaw, Marker, Drill, Tape measure.

USE DOUBLE WHEEL TYPE FOR

- Converting an existing internal hinged door to a sliding door.
- Fitting an internal sliding door to an existing opening.
- Doors up to 3'0" (914mm) use one 3'0" kit, for narrower doors cut track to suit.
- Double doors 2 x 3' (914mm) buy 2 kits.
- Max door weight 30kg (66lbs).
- Min door thickness 22mm (7/8").

KIT CONTAINS

1 top track assembly, 2 trolleys, 2 hangers, 1 guide peg, 2 guide blocks, 2 end stops, 1 bottom channel, fixing screws, nuts and bolts.

TOOLS REQUIRED

Screwdriver, 10mm spanner, Hacksaw, Marker, Drill, Tape measure.

Slik Small Merchandiser



Sapphire Shelving

Twin Slot Uprights



Product Codes Begin **NEWTU** Product Group **5018**



Article No.	Size	Colour	Box Qty.
DU430	430mm / 16.3/4"	White	10
DU710	710mm / 28"	White	10
DU1000	1000mm / 39.1/4"	White	10
DU1220	1220mm / 48"	White	10

DU1600	1600mm / 63"	White	10
DU1980	1980mm / 78"	White	10
DU2400	2400mm / 94.1/4"	White	10

• White brackets & uprights have an Anti-Bacterial coating



DU430CH	430mm / 16.3/4"	Chrome	10
DU710CH	710mm / 28"	Chrome	10
DU1000CH	1000mm / 39.1/4"	Chrome	10
DU1220CH	1220mm / 48"	Chrome	10

DU1600CH	1600mm / 63"	Chrome	10
DU1980CH	1980mm / 78"	Chrome	10
DU2400CH	2400mm / 94.1/4"	Chrome	10

Twin Slot Brackets

Product Codes Begin **NEWTB** Product Group **5018**



SDB120BC	120mm / 5"	White	10
SDB170BC	170mm / 7"	White	10
SDB220BC	220mm / 9"	White	10
SDB270BC	270mm / 10.1/2"	White	10
SDB320BC	320mm / 12.1/2"	White	10
SDB370BC	370mm / 14.1/2"	White	10

DMDB370	370mm / 14.1/2" with 3" Base	White	10
SDB470BC	470mm / 18.1/2" with 3" Base	White	10
DHB470	470mm / 18.1/2" with 4" Base	White	6
SDB610BC	610mm / 24" with 3" Base	White	10
DHB610	610mm / 24" with 4" Base	White	6

• White brackets & uprights have an Anti-Bacterial coating • Drop & Lock Safety Protection Feature



DB120CH	120mm / 5"	Chrome	10
DB170CH	170mm / 7"	Chrome	10
DB220CH	220mm / 9"	Chrome	10
DB270CH	270mm / 10.1/2"	Chrome	10

DB320CH	320mm / 12.1/2"	Chrome	10
DB370CH	370mm / 14.1/2"	Chrome	10
DB470CH	470mm / 18.1/2" with 3" Base	Chrome	10

Reinforced Cantilever Brackets

Product Codes Begin **NEWTB** Product Group **5018**



DRB10	100 × 75mm / 4" × 3"	White	10
DRB15	150 × 120mm / 6" × 5"	White	10
DRB20	200 × 150mm / 8" × 6"	White	10
DRB25	250 × 200mm / 10" × 8"	White	10

Mitred Brackets

Product Codes Begin **NEWTMB** Product Group **5018**



DMB200	200 × 200mm / 8" × 8"	White	10
DMB250	250 × 250mm / 10" × 10"	White	10
DMB300	300 × 300mm / 12" × 12"	White	10
DMB350	350 × 350mm / 14" × 14"	White	10

• Mitred for increased strength



Steel Shelves

Product Codes Begin **NEWSHELF** Product Group **5018**



Article No.	Size	Colour	Box Qty.
DSS1022	1000 × 220mm	White	1
DSS1027	1000 × 270mm	White	1
DSS1032	1000 × 320mm	White	1
DSS1037	1000 × 370mm	White	1
DSS1047	1000 × 470mm	White	1

Twin Slot Shelf Ends

Product Codes Begin **NEWTSE** Product Group **5018**



DSE150	150mm / 6" LH & 6" RH	White	10
DSE200	200mm / 8" LH & 8" RH	White	10

Spring Rod Bookends

Product Codes Begin **NEWTBE** Product Group **5018**



DFB150	150mm / 6"	White	10
DFB200	200mm / 8"	White	10
DFB250	250mm / 10"	White	10

Square Book Support

Product Codes Begin **NEWTBS** Product Group **5018**



FSB150	130mm / 5"	White	10
--------	------------	-------	----

Sapphire Merchandiser

Product Codes Begin **NEWTMERCH** Product Group **5018**





London Pattern Shelf Brackets

Product Codes Begin **9SHELFB** Product Group **5000**

Article No.	Size	Finish / Colour	Box Qty.				
OJ141015	4 × 3	Grey	20	OJ141091	4 × 3	White	20
OJ141022	5 × 4	Grey	20	OJ141107	5 × 4	White	20
OJ141039	6 × 5	Grey	20	OJ141114	6 × 5	White	20
OJ141046	8 × 6	Grey	20	OJ141121	8 × 6	White	20
OJ141053	9 × 7	Grey	20	OJ141138	9 × 7	White	20
OJ141060	10 × 8	Grey	20	OJ141145	10 × 8	White	20
OJ141077	12 × 10	Grey	20	OJ141152	12 × 10	White	20
OJ141084	14 × 12	Grey	20	OJ141169	14 × 12	White	20



Fluted Angle Brackets

Product Codes Begin **9FAB** Product Group **5000**

247 3X2	3 × 2	Galv	20	247 8X6	8 × 6	Galv	20
247 4X3	4 × 3	Galv	20	247 10X8	10 × 8	Galv	20
247 5X4	5 × 4	Galv	20	247 12X10	12 × 10	Galv	20
247 6X5	6 × 5	Galv	20				



Worktop Legs

Product Codes Begin **WORKTOP** Product Group **5018**

Article No.	Size	Finish / Colour	Box Qty.
44001	60 × 710mm	Chrome	1 × 4
44003	60 × 870mm	Chrome	1 × 4



CE13 Hinges

Grade CE13 Stainless Steel Ball Bearing Hinges



Boxed

Product Codes Begin **AIHI** Product Group **203**

Article No.	Size	Finish	Box Qty.	
AIHI3002SSS	102 × 75 × 3mm	CE	SSS	1 Pr
AIHI3006SSS	102 × 75 × 3mm	CE	SSS	1.1/2 Pr
AIHI3003PSS	102 × 75 × 3mm	CE	PSS	1 Pr
AIHI3006PSS	102 × 75 × 3mm	CE	PSS	1.1/2 Pr

Quality & Performance: BS EN 1935 4 7 6 1* 1 4 0 13

Fire Safety: Included in a successful fire test to BS EN 1634 Part1: 2000. For use on a 30 min, 1 hour and 2 hour fire door.



Pre-packed

Product Codes Begin **9HQ** Product Group **5001**

Article No.	Size	Finish	Box Qty.	
HQ2161/4	100 × 75 × 3mm	CE	PSS	4 Bags
HQ2163/4	100 × 75 × 3mm	CE	SSS	4 Bags
HQ2165/4	100 × 75 × 3mm	CE	EB	4 Bags

* Supplied with fixing screws

CE11 Hinges

Grade CE11 Stainless Steel Ball Bearing Hinges



Article No.	Size	Finish	Box Qty.	
HQ2173/4	75 × 50 × 2mm	CE	PSS	4 Bags
HQ2175/4	75 × 50 × 2mm	CE	SSS	4 Bags
HQ2177/4	75 × 50 × 2mm	CE	EB	4 Bags

CE7 Hinges

Grade CE7 Steel Hinges



Article No.	Size	Finish	Box Qty.	
9TQIHINGEC7/005	75mm	CE	ZP	1Pr

Stainless Steel Ball Bearing Hinges



Product Codes Begin **AIHI** Product Group **203**

Article No.	Size	Finish	Box Qty.
AIHI3000SSS	70 × 50 × 2mm	SSS	1 Pr
AIHI3001PSS	70 × 50 × 2mm	PSS	1 Pr



1838 Light Steel Butts

Boxed

Product Group 5000

Article No.	Prod. Code	Size	No. of screws Size mm	Screw size / Screws	Finish	Unit of Sale
1838 1.0	9TQILSB/006	1"	25	4g/8	SC	25
1838 1.5	9TQILSB/011	1.1/2"	38	5g/8	SC	10
1838 2.0	9TQILSB/016	2"	50	6g/8	SC	10
1838 2.5	9TQILSB/021	2.1/2"	65	6g/12	SC	10
1838 3.0	9TQILSB/026	3"	75	7g/12	SC	10
1838 4.0	9TQILSB/031	4"	100	8g/16	SC	5
1838 3.0CP	9TQILSB/005	3"	75	7g/12	CP	10
1838 4.0CP	9TQILSB/010	4"	100	8g/16	CP	5
1838 2.0EB	9TQILSBEB/010	2"	50	6g/8	EB	10
1838 2.5EB	9TQILSBEB/011	2.1/2"	65	6g/12	EB	10
1838 3.0EB	9TQILSBEB/016	3"	75	7g/12	EB	10
1838 4.0EB	9TQILSBEB/021	4"	100	8g/16	EB	5
1838 2.5ZP	9TQILSBZP/011	2.1/2"	65	6g/12	BZP	10
1838 3.0ZP	9TQILSBZP/016	3"	75	7g/12	BZP	10
1838 4.0ZP	9TQILSBZP/021	4"	100	8g/16	BZP	5

• Cranked light weight hinge

Pre-packed

Product Group 5001

HQ1725/4	9HQBUTTLS/1725	2"	50	6g/8	SC	4 Bags
HQ1727/4	9HQBUTTLS/1727	2.1/2"	65	6g/12	SC	4 Bags
HQ1729/4	9HQBUTTLS/1729	3"	75	7g/12	SC	4 Bags
HQ1731/4	9HQBUTTLS/1731	4"	100	8g/16	SC	4 Bags
HQ1739/4	9HQBUTTLSBZ/1739	3"	75	7g/12	BZP	4 Bags
HQ1973/4	9HQBUTTLSBZ/1973	4"	100	8g/16	BZP	4 Bags
HQ1969/4	9HQBUTTLSCP/1969	3"	75	7g/12	CP	4 Bags
HQ1971/4	9HQBUTTLSCP/1971	4"	100	8g/16	CP	4 Bags
HQ1735/4	9HQBUTTLSEB/1735	3"	75	7g/12	EB	4 Bags
HQ1737/4	9HQBUTTLSEB/1737	4"	100	8g/16	EB	4 Bags



453 Stainless Steel Light Butts

Boxed

Product Group 5000

453 3	9TQISSLSB/006	3"	75	7g/12	SSS	10
453 4	9TQISSLSB/011	4"	100	8g/16	SSS	5
453P 3	9TQISSLSB/016	3"	75	7g/12	PSS	10
453P 4	9TQISSLSB/021	4"	100	8g/16	PSS	5



1840 Loose Pin Butts



Boxed

Product Group 5000

Article No.	Prod. Code	Size	No. of screws / Size mm	Screw size / Finish	Unit of Sale
1840 3.0	9TQILPBSC/005	3"	75	7g/12 SC	10
1840 4.0	9TQILPBSC/010	4"	100	8g/16 SC	5
1840 3.0ZP	9TQILPBZP/005	3"	75	7g/12 BZP	10
1840 4.0ZP	9TQILPBZP/010	4"	100	8g/16 BZP	5
1840 3.0EB	9TQILPBEB/005	3"	75	7g/12 EB	10
1840 4.0EB	9TQILPBEB/010	4"	100	8g/16 EB	5
1840 3.0CP	9TQILPBSP/005	3"	75	7g/12 CP	10

Pre-packed

Product Group 5001

HQ1745/2	9HQBUTTLPBZ/1745	3"	75	7g/12 BZP	2 Bags
HQ1741/4	9HQBUTTLPEB/1741	3"	75	7g/12 EB	4 Bags

• Loose pins mean that doors can be taken off without removing hinges

457 Lift Off Butts



Boxed

Product Group 5000

457 LH3	9LOBLH/005	3" LH	75	10g/12 SC	10
457 RH3	9LOBRH/005	3" RH	75	10g/12 SC	10
457 LH4	9LOBLH/010	4" LH	100	10g/16 SC	5
457 RH4	9LOBRH/010	4" RH	100	10g/16 SC	5

• Handed hinges • Two-part hinge splits to facilitate easy removal of the door

200 Cast Butts



Boxed

Product Group 5000

BH325	9TQICBH/005	2" x 1.3/4"	50	10g/12 SC	10
BH326	9TQICBH/010	2.1/2" x 1.3/4"	65	10g/12 SC	10
BH327	9TQICBH/015	3" x 2"	75	10g/16 SC	5
BH328	9TQICBH/020	4" x 2.1/2"	100	10g/16 SC	5

• Manufactured from cast malleable iron

899 Double Pressed Strong Butts



Boxed

Product Group 5000

899SC 3	9TQIDPSB/003	3"	75	12g/16 SC	10
899SC 4	9TQIDPSB/005	4"	100	12g/16 SC	5
899SC 6	9TQIDPSB/008	6"	150	12g/16 SC	2

• A double thickness flap for extra strength



466 Steel Rising Butts

UNIFIX®

Boxed

Product Group 5000

Article No.	Prod. Code	Size	No. of screws / Size mm	Screw size / Size mm	Finish	Unit of Sale
466 LH3	9TQISRBLHSC/006	3" LH	75	8g / 12	SC	5
466 RH3	9TQISRBRHSC/006	3" RH	75	8g / 12	SC	5
466 LH4	9TQISRBLHSC/011	4" LH	100	10g / 16	SC	5
466 RH4	9TQISRBRHSC/011	4" RH	100	10g / 16	SC	5
466ZP LH4	9TQISRBLHWP/011	4" LH	100	10g / 16	BZP	5
466ZP RH4	9TQISRBRHWP/011	4" RH	100	10g / 16	BZP	5
466EB LH3	9TQISRBLHEB/006	3" LH	75	8g / 12	EB	5
466EB RH3	9TQISRBRHEB/006	3" RH	75	8g / 12	EB	5
466EB LH4	9TQISRBLHEB/011	4" LH	100	10g / 16	EB	5
466EB RH4	9TQISRBRHEB/011	4" RH	100	10g / 16	EB	5

Pre-packed

Product Group 5001

HQ1975/2	9HQBUTTRIS/1975	3" LH	75	8g / 12	BZP	2 Bags
HQ1977/2	9HQBUTTRIS/1977	3" RH	75	8g / 12	BZP	2 Bags

• Handed hinges • The design of the hinge causes the door to rise and fall when opened and closed



451 Strong Steel Butts

Boxed

Product Group 5000

451	9TQISSB/011	4"	100	10g / 16	SC	5
451ZP	9TQISSBZP/006	4"	100	10g / 16	BZP	5
451EB	9TQISSBEB/005	4"	100	10g / 16	EB	5



105 Solid Drawn Brass Butts

UNIFIX®

Boxed

Product Group 5000

105/25	9TQISDBH/006	1"	25	4g / 8	BR	10
105/40	9TQISDBH/011	1.1/2"	38	4g / 12	BR	10
105/50	9TQISDBH/016	2"	50	4g / 12	BR	10
105/65	9TQISDBH/021	2.1/2"	65	4g / 12	BR	10
105/75	9TQISDBH/026	3"	75	7g / 12	BR	10
105/100	9TQISDBH/031	4"	100	10g / 16	BR	5

Pre-packed

Product Group 5001

HQ1387/4	9HQBUTTBH/1387	1.1/2"	38	4g / 12	BR	4 Bags
HQ1389/4	9HQBUTTBH/1389	2"	50	4g / 12	BR	4 Bags
HQ1391/4	9HQBUTTBH/1391	2.1/2"	65	4g / 12	BR	4 Bags
HQ1393/4	9HQBUTTBH/1393	3"	75	7g / 12	BR	4 Bags
HQ1395/4	9HQBUTTBH/1395	4"	100	10g / 16	BR	4 Bags



115 Heavy Duty Solid Drawn Brass Butts



Boxed

Product Group 5000

Article No.	Prod. Code	Size	No. of screws Size mm	Screw size / Size mm	Finish	Unit of Sale
115/3	9TQIHDSDBH	3"×1.5/8"	75 x 40	7g/12	BR	10

106 Solid Drawn Brass Butts – Double Steel Washered



Boxed

Product Group 5000

Article No.	Prod. Code	Size	No. of screws Size	Screw size / Size	Finish	Unit of Sale
106/3X2	9TQISDBHDW/021	75 × 50		8g/12	BR	10
106/4X2	9TQISDBHDW/026	100 × 67		10g/16	BR	5
106/4X3	9TQISDBHDW/030	100 × 75		10g/16	BR	5
106P/3X2	9TQISDPBHDW/021	75 × 50		8g/12	PB	10
106P/4X2	9TQISDPBHDW/026	100 × 67		10g/16	PB	5
106P/4X3	9TQISDPBHDW/030	100 × 75		10g/16	PB	5
106C 3	9SDBHDSWCP/035	75 × 50		8g/12	CP	10
106C 4	9SDBHDSWCP/030	100 × 67		10g/16	CP	5

Pre-packed



Product Group 5001

HQ1399/2	9HQBUTTBDRSW/1399	75 × 50		8g/12	BR	2 Bags
HQ1405/4	9HQBUTTBDRSW/1405	75 × 50		8g/12	PB	2 Bags
HQ1407/4	9HQBUTTBDRSW/1407	100 × 67		10g/16	PB	2 Bags
HQ1677/4	9HQBUTTCPDSW/1677	75 × 50		8g/12	CP	2 Bags
HQ1679/4	9HQBUTTCPDSW/1679	100 × 67		10g/16	CP	2 Bags

• Steel washers reduce the wear on the soft brass

108/108P/118P Solid Drawn Brass Butts – Double Phosphor Bronze Washered



Boxed

Product Group 5000

Article No.	Prod. Code	Size	No. of screws Size	Screw size / Size	Finish	Unit of Sale
108P/3X2	9TQISDPBPBW/005	75 × 50		8g/12	PB	10
108P/4X2	9TQISDPBPBW/010	100 × 67		10g/16	PB	5
108P/4X3	9TQISDPBPBW/015	100 × 75		10g/16	PB	5
118P/3X2	9TQISDPHPBW/006	75 × 50		8g/12	PB	10
118P/4X2	9TQISDPHPBW/011	100 × 67		10g/16	PB	5

109P/119P Solid Drawn Brass Ball Bearing Hinge



Boxed

Product Group 5000

Article No.	Prod. Code	No. of screws / Size	Screw size /	Finish	Unit of Sale
109P/4X3	9TQISDBBBM/010	100 × 75	10g / 16	PB	5
119P/4X3	9TQISDBBBHD/010	100 × 75	10g / 16	PB	5

• Ball bearings are housed in four races and give extended life to the hinge

Solid Drawn Brass Parliament Hinges



Pre-packed

Product Group 5001

HQ1423/2	9HQPARLBR/1423	100 × 100 × 150 × 4mm	12g / 16	PB	2 Bags
----------	----------------	-----------------------	----------	----	--------

Brass Counter Hinges



Note: Sold in singles, not pairs



Pre-packed

Product Group 5001

HQ1425/2	9HQHINGECF/1425	102 x 38	10g / 12	PB	4 Bags
----------	-----------------	----------	----------	----	--------

• Used in conjunction with Counterflap Catches below

Brass Counter Flap Catches



Pre-packed

Product Group 5001

Article No.	Prod. Code	Size	Finish	Unit of Sale
HQ1337/4	9HQCATCHBR/1337	60mm	BR	4 Bags



Concealed Hinges

102 Pattern



Boxed

Product Group 5000

Article No.	Prod. Code	Size	Finish	Unit of Sale
102 NP	9CONCEALED/102	35mm	NP	5

• Sprung with an adjustable cruciform plate • 90° opening

Pre-packed

HQ1980/4	9QHINGECONC/1980	35mm	NP	4 Bags of 2
----------	------------------	------	----	-------------

103 Pattern – Snap Fit



Boxed

Product Group 5000

103 NP	9CONCEALED/103	35mm	NP	5
--------	----------------	------	----	---

Pre-packed

Product Group 5001

HQ1981/4	9QHINGECONC/1981	35mm	NP	4 Bags of 2
----------	------------------	------	----	-------------

• Snap fit allows for easy removal of the door • Sprung with an adjustable cruciform plate • 110° opening.

151 Pattern



Boxed

Product Group 5000

151 NP	9CONCEALED/151	35mm	NP	5
--------	----------------	------	----	---

Pre-packed

Product Group 5001

HQ1785/4	9QHINGECONC/1785	35mm	NP	4 Bags of 2
----------	------------------	------	----	-------------

• Sprung with an adjustable cruciform plate • 165° opening

Easy On Hinge



Pre-packed

Product Group 5001

Article No.	Prod. Code	Description	Finish	Unit of Sale
HQ1783/4	9QHINGEEASY/1783	1783/2 NP Easy On Hinge (Pk2)	NP	4 Bags of 2

• This hinge does not require any routing out

Cranked Cabinet Hinges



Boxed

Product Group 5000

Article No.	Prod. Code	No. of screws / Size	Screw size /	Finish	Unit of Sale
107 63BZP	9CCHZP/005	63mm	8g / 12	BZP	10

104 Hurlinges



Boxed

Product Group 5000

Article No.	Prod. Code	No. of screws / Size	Screw size /	Finish	Unit of Sale
104ZP 2	9BZHURL/005	50mm	4g / 8	BZP	25
104ZP 2.5	9BZHURL/010	63mm	5g / 10	BZP	25
104ZP 3	9BZHURL/015	75mm	6g / 12	BZP	25
104ZP 4	9BZHURL/020	100mm	8g / 12	BZP	10
104EB 3	9EBHURL/015	75mm	6g / 12	EB	25
104EB 4	9EBHURL/020	100mm	8g / 12	EB	10

• A flush hinge with self locating lugs on the spine that mark the wood and make fixing easier

105 Flush Hinges



Boxed

Product Group 5000

105/40ZP	9TQIZPFH/005	40mm	4g / 8	BZP	25
105/50ZP	9TQIZPFH/010	50mm	4g / 8	BZP	25
105/60ZP	9TQIZPFH/015	60mm	4g / 10	BZP	25
105/75ZP	9TQIZPFH/020	75mm	6g / 10	BZP	25
105/40EB	9TQIEBFH/005	40mm	4g / 8	EB	25
105/50EB	9TQIEBFH/010	50mm	4g / 8	EB	25
105/60EB	9TQIEBFH/015	60mm	4g / 10	EB	25
105/75EB	9TQIEBFH/020	75mm	6g / 10	EB	25

Pre-packed

Product Group 5001

HQ1767/4	9HQFLUSHBZ/1767	40mm	4g / 8	BZP	4 Bags
HQ1769/4	9HQFLUSHBZ/1769	50mm	4g / 8	BZP	4 Bags
HQ1771/4	9HQFLUSHBZ/1771	60mm	4g / 10	BZP	4 Bags
HQ1773/4	9HQFLUSHBZ/1773	75mm	6g / 10	BZP	4 Bags
HQ1775/4	9HQFLUSHEB/1775	40mm	4g / 8	EB	4 Bags
HQ1777/4	9HQFLUSHEB/1777	50mm	4g / 8	EB	4 Bags
HQ1779/4	9HQFLUSHEB/1779	60mm	4g / 10	EB	4 Bags
HQ1781/4	9HQFLUSHEB/1781	75mm	6g / 10	EB	4 Bags

• Also known as an 'Easyfit' hinge as there is no cutting of wood required for installation



400 Backflap Hinges



Boxed

Product Group 5000

400 1.0	9TQISBH/005	25	6g/12	SC	25
400 1.25	9TQISBH/010	32	7g/12	SC	10
400 1.5	9TQISBH/015	38	8g/12	SC	10
400 2.0	9TQISBH/020	50	8g/12	SC	10
400 2.50	9TQISBH/025	63	10g/12	SC	10
400 3.0	9TQISBH/030	75	10g/12	SC	5

Pre-packed

Product Group 5001

HQ1757/4	9HQBACK/1757	38	8g/12	SC	4 Bags
HQ1759/4	9HQBACK/1759	50	8g/12	SC	4 Bags

• Widely used in cabinet and garden furniture manufacture



1951 Stormproof Hinges



Boxed

Product Group 5000

Article No.	Prod. Code	No. of screws / Size	Screw size / Finish	Unit of Sale
1951ZP	9TQISHZP/006	65	8g/12 BZP	10
1951EB	9TQISHEB/006	65	8g/12 EB	10
1951EXBR 63	9TQISHEXBR/006	65	8g/12 EXBR	10

Pre-packed

Product Group 5001

HQ1753/4	9HQSTORMBZ/1753	2.1/2"	8g/12	BZP	4 Bags
----------	-----------------	--------	-------	-----	--------



488 Steel Parliament Hinges

Boxed

Product Group 5000

488 3	9TQISPH/006	75	10g/12	SC	5
488 4	9TQISPH/011	100	10g/16	SC	5



Double Action Spring Hinges

Boxed

Product Group 5000

Article No.	Prod. Code	Size	Closing Torque	Max Closing Torque at 90° (kgf.m)	Finish	Unit of Sale
OJ077178	9DASH/005	75	20×25mm	0.25	EXS	1
OJ077185	9DASH/010	100	21×30mm	0.35	EXS	1
OJ077192	9DASH/015	125	25×35mm	0.50	EXS	1
OJ077208	9DASH/020	150	25×40mm	0.70	EXS	1
OJ768328	9DASH/025	175	33×55mm	0.80	EXS	1



Tee Hinges

Light Weight

Boxed

Product Group 5000

Article No.	Prod. Code	No. of screws Size	Screw size / Size	Finish	Unit of Sale								
121L 100	9TQIJTH/006	4"	100mm	6g / 12	EXB	10	121LZP 100	9TQIZPTH/006	4"	100mm	6g / 12	BZP	10
121L 150	9TQIJTH/011	6"	150mm	6g / 14	EXB	10	121LZP 150	9TQIZPTH/011	6"	150mm	6g / 14	BZP	10
121L 200	9TQIJTH/016	8"	200mm	6g / 14	EXB	10	121LZP 200	9TQIZPTH/016	8"	200mm	6g / 14	BZP	10
121L 230	9TQIJTH/021	9"	230mm	6g / 14	EXB	10	121LZP 230	9TQIZPTH/021	9"	230mm	6g / 14	BZP	10
121L 250	9TQIJTH/026	10"	250mm	6g / 14	EXB	10	121LZP 250	9TQIZPTH/026	10"	250mm	6g / 14	BZP	10
121L 300	9TQIJTH/031	12"	300mm	6g / 14	EXB	10	121LZP 300	9TQIZPTH/031	12"	300mm	6g / 14	BZP	10

Pre-packed



Product Group 5001

HQ1789/4	9HQTEEXB/1789	4"	100mm	6g / 12	EXB	4 Bags	HQ1801/4	9HQTEEBZ/1801	6"	150mm	6g / 14	BZP	4 Bags
HQ1791/4	9HQTEEXB/1791	6"	150mm	6g / 14	EXB	4 Bags	HQ1803/4	9HQTEEBZ/1803	8"	200mm	6g / 14	BZP	4 Bags
HQ1793/4	9HQTEEXB/1793	8"	200mm	6g / 14	EXB	4 Bags	HQ1799/4	9HQTEEBZ/1799	9"	230mm	6g / 14	BZP	4 Bags
HQ1797/4	9HQTEEXB/1797	9"	230mm	6g / 14	EXB	4 Bags	HQ1805/4	9HQTEEBZ/1805	10"	250mm	6g / 14	BZP	4 Bags
HQ1795/4	9HQTEEXB/1795	10"	250mm	6g / 14	EXB	4 Bags	HQ1807/4	9HQTEEBZ/1807	12"	300mm	6g / 14	BZP	4 Bags
HQ1823/4	9HQTEEXB/1823	12"	300mm	6g / 14	EXB	4 Bags							

* For use on timber doors in a wide range of domestic and agricultural buildings



Medium Weight

Boxed

Product Group 5000

121M 250	9TQIJTH/034	10"	250mm	8g / 16	EXB	5	121MZP 375	9TQIZPTH/041	15"	375mm	10g / 18	BZP	5
121M 300	9TQIJTH/035	12"	300mm	8g / 16	EXB	5	121MZP 400	9TQIZPTH/046	16"	400mm	10g / 18	BZP	5
121M 350	9TQIJTH/036	14"	350mm	8g / 18	EXB	5	121MZP 450	9TQIZPTH/051	18"	450mm	10g / 18	BZP	5
121M 375	9TQIJTH/041	15"	375mm	10g / 18	EXB	5	121MZP 500	9TQIZPTH/056	20"	500mm	10g / 20	BZP	5
121M 400	9TQIJTH/046	16"	400mm	10g / 18	EXB	5	121MZP 600	9TQIZPTH/061	24"	600mm	10g / 20	BZP	5
121M 450	9TQIJTH/051	18"	450mm	10g / 18	EXB	5	121MHSGP 300	9TQIHSGTHBP/010	12"	300mm*	8g / 16	HSG	5
121M 500	9TQIJTH/056	20"	500mm	10g / 20	EXB	5	121MHSG 250	9TQIHSGTH/026	10"	250mm	8g / 16	HSG	5
121M 600	9TQIJTH/061	24"	600mm	10g / 20	EXB	5	121MHSG 300	9TQIHSGTH/031	12"	300mm	8g / 16	HSG	5
121MZP 250	9TQIZPTH/034	10"	250mm	8g / 16	BZP	5	121MHSG 375	9TQIHSGTH/041	15"	375mm	10g / 18	HSG	5
121MZP 300	9TQIZPTH/035	12"	300mm	8g / 16	BZP	5	121MHSG 450	9TQIHSGTH/051	18"	450mm	10g / 18	HSG	5
121MZP 350	9TQIZPTH/036	14"	350mm	8g / 18	BZP	5	121MHSG 600	9TQIHSGTH/061	24"	600mm	10g / 20	HSG	5

Pre-packed



Product Group 5001

HQ1809/2	9HQTEEXB/1809	14"	350mm	8g / 18	EXB	4 Bags	HQ1817/2	9HQTEEBZ/1817	14"	350mm	8g / 18	BZP	4 Bags
HQ1825/2	9HQTEEXB/1825	15"	375mm	10g / 18	EXB	4 Bags	HQ1815/2	9HQTEEBZ/1815	15"	375mm	10g / 18	BZP	4 Bags
HQ1811/2	9HQTEEXB/1811	16"	400mm	10g / 18	EXB	4 Bags	HQ1819/2	9HQTEEBZ/1819	16"	400mm	10g / 18	BZP	4 Bags
HQ1813/2	9HQTEEXB/1813	18"	450mm	10g / 18	EXB	4 Bags	HQ1821/2	9HQTEEBZ/1821	18"	450mm	10g / 18	BZP	4 Bags

* For use on timber doors in a wide range of domestic and agricultural buildings

* Brass Pin



Tee Hinges

Heavy Weight

Boxed

Product Group 5000

Article No.	Prod. Code	No. of screws / Size	Screw size / Finish	Unit of Sale
910 12BZP	9BZHTH/025	12" / 300mm	12g / 16	BZP 5
910 18BZP	9BZHTH/030	18" / 450mm	14g / 18	BZP 2
910 24BZP	9BZHTH/035	24" / 600mm	14g / 18	BZP 2
910 GALV9	9GALVHTH/005	9" / 230mm	10g / 14	HSG 5

910 GALV12	9GALVHTH/010	12" / 300mm	12g / 16	HSG	5
910 GALV15	9GALVHTH/015	15" / 375mm	12g / 18	HSG	2
910 GALV18	9GALVHTH/020	18" / 450mm	14g / 18	HSG	2
910 GALV24	9GALVHTH/025	24" / 600mm	14g / 18	HSG	2

Pre packed



HQ2151/4	9HQTEEGALV/2151	"/ 150mm	/	Galv	
HQ2153/4	9HQTEEGALV/2153	9" / 230mm	/	Galv	
HQ2155/4	9HQTEEGALV/2155	12" / 300mm	/	Galv	

HQ2157/4	9HQTEEGALV/2157	15" / 375mm	/	Galv	
HQ2159/4	9HQTEEGALV/2159	18" / 450mm		Galv	

- For use on timber doors in a wide range of domestic and agricultural buildings



950 Strap Hinges

Boxed

Product Group 5000

950L 100	9TQISTRAPH/005	100	6g / 12	SC	10
950L 150	9TQISTRAPH/010	150	8g / 16	SC	10
950L 200	9TQISTRAPH/015	200	8g / 16	SC	5

950M 250	9TQISTRAPH/020	250	12g / 20	SC	5
950M 300	9TQISTRAPH/025	300	12g / 20	SC	5

- Used in the manufacture of trestle tables and cold frames



140 Hook Only on Plate

Boxed

Product Group 5000

140EXB 12	9EXBHCRP/010	12mm Pin	12g / 8	EXB	10
OJ147857	9GALVHKRP/010	12mm Pin	12g / 8	HSG	5
OJ147864	9GALVHKRP/015	16mm Pin	14g / 8	HSG	5

- Sold in pairs



499 Heavy Reversible Hinges

Boxed

Product Group 5000

Article No.	Prod. Code	Size	Screw size / Pin Size	Finish	Unit of Sale
127/12"	9EXBHREHV/002	300	14g / 11mm	EXB	2
127/14"	9EXBHREHV/003	350	14g / 12mm	EXB	2
127/16"	9EXBHREHV/004	400	14g / 16mm	EXB	2
127/18"	9EXBHREHV/005	450	14g / 16mm	EXB	1
127/20"	9EXBHREHV/007	500	14g / 16mm	EXB	1
127/24"	9EXBHREHV/010	600	14g / 16mm	EXB	1
127/30"	9EXBHREHV/015	750	14g / 19mm	EXB	1
127/36"	9EXBHREHV/020	900	14g / 22mm	EXB	1

127/12"GALV	9GALVHREHV/002	300	14g / 11mm	HDG	2
127/14"GALV	9GALVHREHV/003	350	14g / 12mm	HDG	2
127/16"GALV	9GALVHREHV/004	400	14g / 16mm	HDG	2
127/18"GALV	9GALVHREHV/005	450	14g / 16mm	HDG	1
127/20"GALV	9GALVHREHV/007	500	14g / 16mm	HDG	1
127/24"GALV	9GALVHREHV/010	600	14g / 16mm	HDG	1
127/30"GALV	9GALVHREHV/015	750	14g / 19mm	HDG	1
127/36"GALV	9GALVHREHV/020	900	14g / 22mm	HDG	1

- Cast iron cups hold steel bands in position and prevent the gate being removed • Used extensively on stables and garages



1055 Hook & Band Hinges

Boxed

Product Group 5000

Article No.	Prod. Code	No. of screws / Size	Screw size / Finish	Unit of Sale							
1055/128L 12EXB	9EXBLHKRPB/010	12" 300mm	12g/12	EXB	2	1055/128 24"HSG	9GALVHHKRP/020	24" 600mm	12g/14	HSG	1
1055/128L 16EXB	9EXBLHKRPB/020	16" 400mm	12g/14	EXB	2	1055/128 30"HSG	9GALVHHKRP/025	30" 750mm	12g/16	HSG	1
1055/128 18EXB	9EXBHHKRPB/015	18" 450mm	14g/14	EXB	1	1055/128 36"HSG	9GALVHHKRP/030	36" 900mm	14g/16	HSG	1
1055EXB 24	9EXBHHKRPB/020	24" 600mm	14g/14	EXB	1						
1055EXB 30	9EXBHHKRPB/025	30" 750mm	14g/16	EXB	1						
1055EXB 36	9EXBHHKRPB/030	36" 900mm	14g/16	EXB	1						
1055/128 12"HSG	9GALVHHKRP/004	12" 300mm	12g/12	HSG	2						
1055/128 14"HSG	9GALVHHKRP/005	14" 350mm	12g/12	HSG	2						
1055/128 16"HSG	9GALVHHKRP/009	16" 400mm	12g/14	HSG	2						
1055/128 18"HSG	9GALVHHKRP/010	18" 450mm	12g/14	HSG	1						
1055/128 20"HSG	9GALVHHKRP/015	20" 500mm	12g/14	HSG	1						

• Also known as hook and ride hinges



1056 Cranked Hook & Band Hinges

Boxed

Product Group 5000

1056/130 12"EXB	9EXBCHHKRP/004	12" 300mm	12g/12	EXB	2	1056/130 14"HSG	9GALVCHHKRP/005	14" 350mm	12g/12	HSG	2
1056/130 14"EXB	9EXBCHHKRP/005	14" 350mm	12g/12	EXB	2	1056/130 16"HSG	9GALVCHHKRP/010	16" 400mm	12g/14	HSG	2
1056/130 16"EXB	9EXBCHHKRP/010	16" 400mm	12g/14	EXB	2	1056/130 18"HSG	9GALVCHHKRP/015	18" 450mm	12g/14	HSG	1
1056/130 18"EXB	9EXBCHHKRP/015	18" 450mm	14g/14	EXB	1	1056/130 20"HSG	9GALVCHHKRP/019	20" 500mm	12g/14	HSG	1
1056/130 24"EXB	9EXBCHHKRP/020	24" 600mm	14g/14	EXB	1	1056/130 24"HSG	9GALVCHHKRP/020	24" 600mm	12g/14	HSG	1
1056/130 30"EXB	9EXBCHHKRP/025	30" 750mm	14g/16	EXB	1	1056/130 30"HSG	9GALVCHHKRP/025	30" 750mm	12g/16	HSG	1
1056/130 36"EXB	9EXBCHHKRP/030	36" 900mm	14g/16	EXB	1	1056/130 36"HSG	9GALVCHHKRP/030	36" 900mm	14g/16	HSG	1
1056/130 12"HSG	9GALVCHHKRP/004	12" 300mm	12g/12	HSG	2						

• Also known as hook and ride hinges



131/B Hook to Bolt

Boxed

Product Group 5000

Article No.	Prod. Code	Size	Finish	Unit of Sale
131/B	9GALVHKB/005	19mm	HSG	5

• For use with hooks and bands on wooden posts from 3"-8"



131/D Hook to Drive

Boxed

Product Group 5000

131/D	9GALVHKD/005	19mm	HSG	5
-------	--------------	------	-----	---

• For use with wooden posts • 19mm / 3/4" pin



Black Antique Hinges

Ornate Coronet Hinges



Boxed

Product Group 5000

Article No.	Prod. Code	Size	Finish	Unit of Sale
KX952	9KXANTIQUE/952	300mm	B/ANT	5

Unequal Hinges



Boxed

Product Group 5000

KX953	9KXANTIQUE/953	89mm	B/ANT	10
-------	----------------	------	-------	----

Spear Hinges



Boxed

Product Group 5000

KX954	9KXANTIQUE/954	150mm	B/ANT	10	A
KX955	9KXANTIQUE/955	229mm	B/ANT	5	
KX969	9KXANTIQUE/969	229mm	B/ANT	5	B



Butterfly Hinges



Boxed

Product Group 5000

KX956	9KXANTIQUE/956	75mm	B/ANT	25
-------	----------------	------	-------	----

Butterfly Front



Pre-packed



Product Group 5001

HQ1463/4	9HQHINGEBANT/1463	400mm	B/ANT	4 Bags
----------	-------------------	-------	-------	--------

Plain Hinges



Boxed

Product Group 5000

Article No.	Prod. Code	Size	Finish	Unit of Sale
KX968	9KXANTIQUE/968	229mm	B/ANT	Each

101 Continuous Hinges



Boxed

Product Group 5000

Article No.	Prod. Code	Size	Finish	Unit of Sale
102/S25EB	9TQICONTEB/018	25mm × 0.9m	EB	10
101/S25EB	9TQICONTEB/015	25mm × 1.8m	EB	10
101/S25NP	9TQICONTEB/010	25mm × 1.8m	NP	10
101/S32EB	9TQICONTEB/020	32mm × 1.8m	EB	10
101/S32NP	9TQICONTEB/015	32mm × 1.8m	NP	10
101SZP 1200	9TQICONTZP/005	76mm × 1.2m	BZP	5
101SZP 1500	9TQICONTZP/010	76mm × 1.5m	BZP	5
101SZP 1800	9TQICONTZP/015	76mm × 1.8m	BZP	5

• Also known as piano hinge

Handles

Lichfield



Article No.	Prod. Code	Description	Finish	Prod. Group	
KX323	9KXALUM/323	Lever - Lock	SAA	5000	<input checked="" type="checkbox"/>
KX324	9KXALUM/324	Lever - Latch	SAA	5000	<input checked="" type="checkbox"/>
KX325	9KXALUM/325	Lever - Privacy	SAA	5000	<input checked="" type="checkbox"/>
HQ1001/4	9HQFURNLICH/1001	Lever - Lock	SAA	5001	<input type="checkbox"/>
HQ1003/2	9HQFURNLICH/1003	Lever - Latch	SAA	5001	<input type="checkbox"/>
HQ1005/2	9HQFURNLICH/1005	Lever - Privacy	SAA	5001	<input type="checkbox"/>

• Cast handle • Extruded backplate with black end caps

Wells



Article No.	Prod. Code	Description	Finish	Prod. Group	
KX332	9KXALUM/332	Lever - Lock	PAA	5000	<input checked="" type="checkbox"/>
KX333	9KXALUM/333	Lever - Latch	PAA	5000	<input checked="" type="checkbox"/>
KX334	9KXALUM/334	Lever - Privacy	PAA	5000	<input checked="" type="checkbox"/>
KX335	9KXALUM/335	Lever - Euro Profile	PAA	5000	<input checked="" type="checkbox"/>
HQ1009/2	9HQFURNWELLS/1009	Lever - Lock	PAA	5001	<input type="checkbox"/>
HQ1011/2	9HQFURNWELLS/1011	Lever - Latch	PAA	5001	<input type="checkbox"/>
HQ1013/2	9HQFURNWELLS/1013	Lever - Privacy	PAA	5001	<input type="checkbox"/>
HQ1015/2	9HQFURNWELLS/1015	Lever - Euro Profile	PAA	5001	<input type="checkbox"/>

• Cast handle • Pressed backplate



A

Rochester

Boxed



B

KX342	9KXALUM/342	Round Rose 19mm	PAA	5000	<input checked="" type="checkbox"/>	A
KX343	9KXALUM/343	Lever – Lock 19mm	PAA	5000	<input checked="" type="checkbox"/>	
KX344	9KXALUM/344	Lever – Latch 19mm	PAA	5000	<input checked="" type="checkbox"/>	B
KX346P	9KXALUMP/346	Lever – Euro Profile	PAA	5000	<input checked="" type="checkbox"/>	

• 19mm round bar cast handle • Concealed fixing backplates



Chichester

Pre packed



HQ1093/2	9HQFURNCHICH/1093	Lever – Lock	PAA	5001	<input type="checkbox"/>
HQ1095/2	9HQFURNCHICH/1095	Lever – Latch	PAA	5001	<input type="checkbox"/>
HQ1097/2	9HQFURNCHICH/1097	Lever – Privacy	PAA	5001	<input type="checkbox"/>

• Cast straight handle • Pressed backplate

Handles Designer Range



Hereford

Pre packed

Article No.	Prod. Code	Description	Finish	Prod. Group	
HQ3000/2	9HQDESIGN/3000	Lever on Rose	SCP	5001	<input type="checkbox"/>
HQ3001/2	9HQDESIGN/3001	Lever on Rose	PC	5001	<input type="checkbox"/>



Exeter

Pre packed

HQ3005/2	9HQDESIGN/3005	Lever on Rose	SCP	5001	<input type="checkbox"/>
HQ3006/2	9HQDESIGN/3006	Lever on Rose	PC	5001	<input type="checkbox"/>



Westminster Duo Tone

Pre packed

H3010/2	9HQDESIGN/3010	Lever on Rose	PC/SCP	5001	<input type="checkbox"/>
---------	----------------	---------------	--------	------	--------------------------



Canterbury

Pre packed

HQ3030/2	9HQDESIGN/3030	Lever - Lock	PC	5001	<input type="checkbox"/>
HQ3035/2	9HQDESIGN/3035	Lever - Long Latch	PC	5001	<input type="checkbox"/>
HQ3040/2	9HQDESIGN/3040	Lever - Bathroom	PC	5001	<input type="checkbox"/>
HQ3045/2	9HQDESIGN/3045	Lever - Lock	SCP	5001	<input type="checkbox"/>
HQ3050/2	9HQDESIGN/3050	Lever - Long Latch	SCP	5001	<input type="checkbox"/>
HQ3055/2	9HQDESIGN/3055	Lever - Bathroom	SCP	5001	<input type="checkbox"/>

• Forged handle and plates • Electro phoretic finished



Ely

Pre packed

HQ3070/2	9HQDESIGN/3070	Lever - Lock	PC	5001	<input type="checkbox"/>
HQ3075/2	9HQDESIGN/3075	Lever - Long Latch	PC	5001	<input type="checkbox"/>
HQ3080/2	9HQDESIGN/3080	Lever - Bathroom	PC	5001	<input type="checkbox"/>
HQ3085/2	9HQDESIGN/3085	Lever - Lock	SCP	5001	<input type="checkbox"/>
HQ3090/2	9HQDESIGN/3090	Lever - Long Latch	SCP	5001	<input type="checkbox"/>
HQ3095/2	9HQDESIGN/3095	Lever - Bathroom	SCP	5001	<input type="checkbox"/>

• Forged handle and plates • Electro phoretic finished



Handles Brass Lever

Budget Victorian



Pre packed

Article No.	Prod. Code	Description	Finish	Prod. Group	
HQ1213/2	9HQFURNBVIC/1213	Lever – Lock	PLB	5001	<input type="checkbox"/>
HQ1215/2	9HQFURNBVIC/1215	Lever – Latch	PLB	5001	<input type="checkbox"/>
HQ1575/2	9HQFURNCP/1575	Lever – Lock	CP	5001	<input type="checkbox"/>
HQ1577/2	9HQFURNCP/1577	Lever – Latch	CP	5001	<input type="checkbox"/>
HQ1579/2	9HQFURNCP/1579	Lever – Bathroom	CP	5001	<input type="checkbox"/>

• Straight handle • Sand cast

Premium Victorian Scroll



Pre packed

HQ1177/2	9HQSCROLLPVIC/1177	Lever – Lock	EPB	5001	<input type="checkbox"/>
HQ1179/2	9HQSCROLLPVIC/1179	Lever – Latch	EPB	5001	<input type="checkbox"/>
HQ1181/2	9HQSCROLLPVIC/1181	Lever – Privacy	EPB	5001	<input type="checkbox"/>
HQ1183/2	9HQSCROLLPVIC/1183	Lever – Bathroom	EPB	5001	<input type="checkbox"/>

• Hot forged scroll handle • Electro phoretic coating

Budget Victorian Scroll



Pre packed

HQ1187/4	9HQSCROLLBVIC/1187	Lever – Lock	PLB	5001	<input type="checkbox"/>
HQ1189/4	9HQSCROLLBVIC/1189	Lever – Latch	PLB	5001	<input type="checkbox"/>
HQ1581/2	9HQSCROLLCP/1581	Lever – Lock	CP	5001	<input type="checkbox"/>
HQ1583/2	9HQSCROLLCP/1583	Lever – Latch	CP	5001	<input type="checkbox"/>
HQ1585/2	9HQSCROLLCP/1585	Lever – Bathroom	CP	5001	<input type="checkbox"/>

• Scroll handle • Sand cast

Handles Lever

Premium Georgian



Pre packed

Article No.	Prod. Code	Description	Finish	Prod. Group	
HQ1131/2	9HQFURNPGE0/1131	Lever – Lock	EPB	5001	<input type="checkbox"/>
HQ1133/2	9HQFURNPGE0/1133	Lever – Latch	EPB	5001	<input type="checkbox"/>
HQ1135/2	9HQFURNPGE0/1135	Lever – Privacy	EPB	5001	<input type="checkbox"/>
HQ1137/2	9HQFURNPGE0/1137	Lever – Bathroom	EPB	5001	<input type="checkbox"/>

• Hot forged handle • Electro phoretic coating



Black Antique Lever Handles

Traditional



KX900	9KXANTIQUE/900	Lever – Lock	B/ANT	5000	<input checked="" type="checkbox"/>
KX951	9KXANTIQUE/951	Lever – Lock, Narrow Style	B/ANT	5000	<input checked="" type="checkbox"/>
HQ1427	9HQFURNBANT/1427	Lever – Lock	B/ANT	5001	<input type="checkbox"/>
HQ1429	9HQFURNBANT/1429	Lever – Latch	B/ANT	5001	<input type="checkbox"/>
HQ1431	9HQFURNBANT/1431	Lever – Bathroom	B/ANT	5001	<input type="checkbox"/>

Ornate



KX906	9KXANTIQUE/906	Lever – Lock	B/ANT	5000	<input checked="" type="checkbox"/>
HQ1433	9HQFURNBANT/1433	Lever – Lock	B/ANT	5001	<input type="checkbox"/>
HQ1435	9HQFURNBANT/1435	Lever – Latch	B/ANT	5001	<input type="checkbox"/>

Aluminium Concealed Fix Pull Handles

19mm Diameter



Article No.	Prod. Code	Size	Finish	Unit of Sale	Prod. Group	
KX352	9KXALUM/352	150mm	PAA	10	5000	<input checked="" type="checkbox"/>
KX353	9KXALUM/353	225mm	PAA	10	5000	<input checked="" type="checkbox"/>
KX354	9KXALUM/354	300mm	PAA	10	5000	<input checked="" type="checkbox"/>
HQ1069/4	9HQHANDLEAA/1069	150mm	PAA	4 Bags	5001	<input type="checkbox"/>
HQ1071/4	9HQHANDLEAA/1071	225mm	PAA	4 Bags	5001	<input type="checkbox"/>
HQ1125/4	9HQHANDLEAA/1125	300mm	PAA	4 Bags	5001	<input type="checkbox"/>

• 19mm round bar

Oval Grip Handles – Aluminium



KX357	9KXALUM/357	225mm	SAA	10	5000	<input checked="" type="checkbox"/>
HQ1061/2	9HQHANDLEAA/1061	225mm	SAA	4 Bags	5001	<input type="checkbox"/>



Pull Handles

Oval Grip Handles – Brass



Article No.	Prod. Code	Size	Finish	Unit of Sale	Prod. Group	
HQ1259/2	9HQHANDLEVIC/1259	225mm	PLB	2 Bags	5001	<input type="checkbox"/>
HQ1613/2	9HQHANDLECP/1613	225mm	CP	2 Bags	5001	<input type="checkbox"/>

Hot Bed Handles



Article No.	Prod. Code	No. of screws / Size	Screw size / Finish	Unit of Sale	Prod. Group		
44/6	9TQIEXBHBH/005	150mm	8g/4	EXB	25	5000	<input checked="" type="checkbox"/>
44/7	9TQIEXBHBH/010	175mm	8g/4	EXB	25	5000	<input checked="" type="checkbox"/>
44GALV 6	9GALVHBH/005	150mm	8g/4	Galv	25	5000	<input checked="" type="checkbox"/>
44GALV 7	9GALVHBH/010	175mm	8g/4	Galv	25	5000	<input checked="" type="checkbox"/>
HQ1877/4	9HQHANDLEEXB/1877	150mm	8g/4	EXB	4 Bags of 2	5001	<input type="checkbox"/>
HQ1879/4	9HQHANDLEEXB/1879	175mm	8g/4	EXB	4 Bags of 2	5001	<input type="checkbox"/>

Bow Handles – Aluminium



Article No.	Prod. Code	Size	Finish	Unit of Sale	Prod. Group	
KX363	9KXALUM/363	150mm	SAA	10	5000	<input checked="" type="checkbox"/>
HQ1063/4	9HQHANDLEAA/1063	150mm	SAA	4 Bags	5001	<input type="checkbox"/>

Bow Handles – Brass



HQ1257/4	9HQHANDLEVIC/1257	150mm	PLB	4 Bags	5001	<input type="checkbox"/>
HQ1611/4	9HQHANDLECP/1611	150mm	CP	4 Bags	5001	<input type="checkbox"/>

Tubular Handles



Article No.	Prod. Code	No. of screws / Size	Screw size / Finish	Unit of Sale	Prod. Group		
332 6.0	9JTUBH/005	150mm	8g/4	EXB	20 Prs	5000	<input checked="" type="checkbox"/>

D Handles – Aluminium

UNIFIX®



Article No.	Prod. Code	Size	Finish	Unit of Sale	Prod. Group	
KX351	9KXALUM/351	100	SAA	10	5000	<input checked="" type="checkbox"/>
KX349	9KXALUM/349	150	SAA	10	5000	<input checked="" type="checkbox"/>
HQ1073/4	9HQHANDLEAA/1073	100	SAA	4 Bags	5001	<input type="checkbox"/>
HQ1129/2	9HQHANDLEAA/1129	150	SAA	4 Bags	5001	<input type="checkbox"/>

• 7mm diameter bar • Complete with fixings

D Handles – Brass

UNIFIX®



HQ1265/2	9HQHANDLEVIC/1265	100mm	PLB	4 Bags	5001	<input type="checkbox"/>
----------	-------------------	-------	-----	--------	------	--------------------------

• 7mm diameter bar • Complete with fixings

Brass Sash Pulls

UNIFIX®



HQ1251/4	9HQSASHVIC/1251	100	PLB	4 Bags	5001	<input type="checkbox"/>
HQ1253/4	9HQSASHVIC/1253	150	PLB	4 Bags	5001	<input type="checkbox"/>
HQ1605/4	9HQSASHCP/1605	100	PC	4 Bags	5001	<input type="checkbox"/>
HQ1607/4	9HQSASHCP/1607	150	PC	4 Bags	5001	<input type="checkbox"/>

Black Antique Ornate Pull Handles

UNIFIX®



KX961	9KXANTIQUE/961	100mm	B/ANT	50	5000	<input checked="" type="checkbox"/>
KX962	9KXANTIQUE/962	128mm	B/ANT	25	5000	<input checked="" type="checkbox"/>
KX963	9KXANTIQUE/963	175mm	B/ANT	5	5000	<input checked="" type="checkbox"/>
HQ1473/4	9HQHANDLEBANT/1473	100mm	B/ANT	4 Bags	5001	<input type="checkbox"/>
HQ1475/4	9HQHANDLEBANT/1475	175mm	B/ANT	4 Bags	5001	<input type="checkbox"/>

Aluminium Flush Pulls

UNIFIX®



HQ1075/2	9HQHANDLEAA/1075	90	SAA	4 Bags	5001	<input type="checkbox"/>
----------	------------------	----	-----	--------	------	--------------------------

Brass Flush Pulls

UNIFIX®



HQ1261/4	9HQHANDLEVIC/1261	90	PLB	4 Bags	5001	<input type="checkbox"/>
----------	-------------------	----	-----	--------	------	--------------------------

Chest Handles

UNIFIX®



246	9JCHH/005	100	EXB	5 Prs	5000	<input checked="" type="checkbox"/>
-----	-----------	-----	-----	-------	------	-------------------------------------



Door Knobs

Black Antique Oval Mortice Knobs



Article No.	Prod. Code	Size	Finish	Unit of Sale	Prod. Group	
HQ1437/2	9HQKNOBBANT/1437	65mm	B/ANT	2 Cards	5001	<input type="checkbox"/>

Brass Mortice Knobs



Article No.	Prod. Code	Size	Finish	Unit of Sale	Prod. Group	
HQ1227/2	9HQKNOBVIC/1227	57mm Sprung	PLB	2 Bags	5001	<input type="checkbox"/>
HQ1589/2	9HQKNOBCP/1589	57mm Sprung	CP	2 Bags	5001	<input type="checkbox"/>
HQ1685/4	9HQKNOBCP/1685	50mm Unsprung	CP	4 Bags	5001	<input type="checkbox"/>
HQ1703/2	9HQKNOBSN/1703	50mm Unsprung	SNP	2 Bags	5001	<input type="checkbox"/>

Brass Rim Knobs



KX425	9KXVIC/425	53mm Unsprung	PLB	1 Set	5000	<input checked="" type="checkbox"/>
HQ1385/2	9HQKNOBVIC/1385	57mm Unsprung	PLB	2 Cards	5001	<input type="checkbox"/>

Black Antique Rim Knobs



KX925	9KXANTIQUE/925	Ball Knob	B/ANT	1 Set	5000	<input checked="" type="checkbox"/>
-------	----------------	-----------	-------	-------	------	-------------------------------------

Plastic Rim/Mortice Knobs



Article No.	Prod. Code	Size	Finish	Unit of Sale	Prod. Group	
KX147	9KXPLASFURN/147	50mm	White	10	5000	<input checked="" type="checkbox"/>
KX148	9KXPLASFURN/148	50mm	Black	10	5000	<input checked="" type="checkbox"/>
KX149	9KXPLASFURN/149	50mm	Brown	10	5000	<input checked="" type="checkbox"/>
HQ2079/4	9HQFURNRIM/2079	50mm	White	4 Bags	5001	<input type="checkbox"/>
HQ2081/4	9HQFURNRIM/2081	50mm	Black	4 Bags	5001	<input type="checkbox"/>
HQ2083/4	9HQFURNRIM/2083	50mm	Brown	4 Bags	5001	<input type="checkbox"/>

• Comes with 2 escutcheons, 2 roses and 2 knobs, with a drilled and tapped spindle • Suitable for both rim and mortice application



Brass



Article No.	Prod. Code	Size	Finish	Unit of Sale	Prod. Group	
HQ1267/4	9HQKNOBVIC/1267	25mm	PLB	4 Bags of 2	5001	<input type="checkbox"/>
HQ1269/4	9HQKNOBVIC/1269	32mm	PLB	4 Bags of 2	5001	<input type="checkbox"/>
HQ1271/4	9HQKNOBVIC/1271	38mm	PLB	4 Bags of 2	5001	<input type="checkbox"/>
HQ1615/4	9HQKNOBCP/1615	25mm	CP	4 Bags of 2	5001	<input type="checkbox"/>
HQ1617/4	9HQKNOBCP/1617	32mm	CP	4 Bags of 2	5001	<input type="checkbox"/>
HQ1619/4	9HQKNOBCP/1619	38mm	CP	4 Bags of 2	5001	<input type="checkbox"/>



Pine



Article No.	Prod. Code	Size	Finish	Unit of Sale	Prod. Group	
HQ2087/4	9HQKNOBPINE/2087	35mm	Pine	4 Bags of 2	5001	<input type="checkbox"/>



Door Escutcheons



Pre-packed

Article No.	Description	Finish	Unit of Sale	Prod. Grp
HQ3205/4	Keytype Open Set	SCP	4 Bags of 2	5001
HQ3210/4	Keytype Open Set	PCSCP	4 Bags of 2	5001
HQ3215/4	Euro Open Set	SCP	4 Bags of 2	5001
HQ3220/4	Euro Open Set	PCSCP	4 Bags of 2	5001

• Woodscrews & bolt fixings included • Supplied in pairs

Aluminium



Article No.	Prod. Code	Description	Finish	Unit of Sale	Prod. Grp	
KX330	9KXALUM/330	Escutcheon Plate – Open	SAA	10	5000	<input checked="" type="checkbox"/>
KX331	9KXALUM/331	Escutcheon Plate – Covered	SAA	10	5000	<input checked="" type="checkbox"/>

Brass



Article No.	Prod. Code	Description	Finish	Unit of Sale	Prod. Group	
HQ1249/4	9HQESCUTCHVIC/1249	Victorian Brass – Covered	PLB	4 Bags of 2	5001	<input type="checkbox"/>
HQ1675/4	9QESCUTHEONCP/1675	Victoria Brass Set - Covered/Open	CP	4 Bags of 2	5001	<input type="checkbox"/>



Black Antique



Article No.	Prod. Code	Description	Finish	Unit of Sale	Prod. Grp	
KX957	9KXANTIQUE/957	Plain Oval – Open 50mm	B/ANT	10	5000	<input checked="" type="checkbox"/>
HQ1453/4	9HQESCUTCHBANT/1453	Ornate – Covered 50mm	B/ANT	4 Bags	5001	<input type="checkbox"/>

Indicating Bolts



ASSA ABLOY



Article No.	Prod. Code	Finish	Prod. Grp	
8094 SCP	9INDB/005	SC	5074	<input checked="" type="checkbox"/>
DY8094 SC	9DYINDB/005	SC	5074	<input type="checkbox"/>

• Suitable for wooden doors between 28 and 48mm

Indicating Bolts



Product Group 5001



Article No.	Prod. Code	Finish	Unit of Sale	
HQ1059/4	9HQINDBAA/1059	SAA	4 Bags	<input type="checkbox"/>

Turn and Release



Product Group 5001



Article No.	Prod. Code	Description	Finish	Unit of Sale	
HQ3225/4	9DESIGN/3225	Bathroom Turn & Indicator, 4mm High	PC	4 Bags	<input type="checkbox"/>
HQ3230/4	9DESIGN/3230	Bathroom Turn & Indicator, 4mm High	SCP	4 Bags	<input type="checkbox"/>

Door & Cupboard Catches

Magnetic Catches



A



B

Product Codes begin **9MAPCATCH** Product Group **5026**

Article No.	Description	Finish	Unit of Sale	
121 02	Small	White	12	A
122 02	Medium	White	12	
122 04	Medium	Brown	10	B
123 02	Large	White	6	
123 04	Large	Brown	6	

Door & Cupboard Catches

Magnetic Catches



A



B



Article No.	Prod. Code	Description	Finish	Unit of Sale	Prod. Grp		
KX288	9KXCATCH/288	Medium 4kg Pull	White	10	5000	<input checked="" type="checkbox"/>	A
KX289	9KXCATCH/289	Large 6kg Pull	White	10	5000	<input checked="" type="checkbox"/>	
KX293	9KXCATCH/293	Large 6kg Pull	Brown	10	5000	<input checked="" type="checkbox"/>	B
HQ2003/4	9HQCATCHMAG/2003	Medium 4kg Pull	White	4 Bags of 2	5001	<input type="checkbox"/>	
HQ2005/4	9HQCATCHMAG/2005	Large 6kg Pull	White	4 Bags of 2	5001	<input type="checkbox"/>	

Door & Cupboard Catches

Roller Door Catches

Product Codes begin **9MAPCATCH** Product Group **5026**

Article No.	Prod. Code	Description	Finish	Unit of Sale
101 02	9MAPCATCH/005	Single Roller	White	6

• An adjustable mortice fixing roller catch • Usage: Suitable for internal use



Door & Cupboard Catches

Roller Door Catches

UNIFIX®



A



B

Article No.	Prod. Code	Description	Finish	Unit of Sale	Prod. Grp		
KX280	9KXCATCH/280	Single Roller	NP	10	5000	<input checked="" type="checkbox"/>	
KX281	9KXCATCH/281	Single Roller	EB	10	5000	<input checked="" type="checkbox"/>	A
KX284	9KXCATCH/284	Double Roller	NP	10	5000	<input checked="" type="checkbox"/>	B
HQ1995/4	9HQCATCHNP/1995	Single Roller	NP	4 Bags	5001	<input type="checkbox"/>	
HQ1997/4	9HQCATCHEB/1997	Single Roller	EB	4 Bags	5001	<input type="checkbox"/>	
HQ1999/4	9HQCATCHBZ/1999	Double Roller	NP	4 Bags	5001	<input type="checkbox"/>	

Double Ball Catches

UNIFIX®



Article No.	Prod. Code	Size	Finish	Unit of Sale	Prod. Grp	
HQ1339/4	9HQCATCHBR/1339	40mm	Brass	4 Bags	5001	<input type="checkbox"/>
HQ1341/4	9HQCATCHBR/1341	50mm	Brass	4 Bags	5001	<input type="checkbox"/>

Bales Catches

UNIFIX®



Article No.	Prod. Code	Size	Finish	Unit of Sale	Prod. Grp	
HQ2007/4	9HQCATCHEB/2007	16mm	EB	4 Bags of 2	5001	<input type="checkbox"/>
HQ2009/4	9HQCATCHEB/2009	19mm	EB	4 Bags of 2	5001	<input type="checkbox"/>

Turn Cupboard Catch

UNIFIX®



Article No.	Prod. Code	Size	Finish	Unit of Sale	Prod. Grp	
HQ1983/4	9HQCATCHCP/1983	45mm	CP	4 Bags	5001	<input type="checkbox"/>
HQ2001/4	9HQCATCHEB/2001	45mm	EB	4 Bags	5001	<input type="checkbox"/>

Touch Latch

UNIFIX®



Article No.	Prod. Code	Finish	Unit of Sale	Prod. Grp	
HQ2011/4	9HQTOUCHBZ/2011	BZP	4 Bags	5001	<input type="checkbox"/>

Letter Plates

Aluminium Front Fix



Article No.	Prod. Code	Size	Finish	Unit of Sale	Prod. Grp	
KX310	9KXALUM/310	250×75	SAA	5	5000	<input checked="" type="checkbox"/>
KX311	9KXALUM/311	300×75	SAA	5	5000	<input checked="" type="checkbox"/>
HQ1027/2	9HQLETPAA/1027	250×75	SAA	2 Bags	5001	<input type="checkbox"/>

• Attached by four front fix screws

Aluminium Rear Fix



HQ1025/2	9HQLETPAA/1025	250×75	SAA	2 Bags	5001	<input type="checkbox"/>
----------	----------------	--------	-----	--------	------	--------------------------

• Attached by two rear fix bolts

Brass



HQ1231/2	9HQLETPVIC/1231	250 x 75	PLB	2 Bags	5001	<input type="checkbox"/>
HQ1593/2	9HQLETPCP/1593	250 x 75	CP	2 Bags	5001	<input type="checkbox"/>
HQ1381/2	9HQKNOCKVIC/1381	250 x 75 *	PLB	2 Bags	5001	<input type="checkbox"/>

• Attached by two rear fix bolts

* With Knocker



Brass Internal Letter Flap



HQ1235/2	9HQLETPVIC/1235	250mm	PLB	2 Bags	5001	<input type="checkbox"/>
HQ1595/2	9HQLETPCP/1595	250mm	CP	2 Bags	5001	<input type="checkbox"/>

• Attached by two rear fix bolts



Letter Plates

Black Antique – Traditional Design



Article No.	Prod. Code	Size	Finish	Unit of Sale	Prod. Grp	
HQ1445/2	9HQLETPBANT/1445	250 x 75	B/ANT	2 Bags	5001	<input type="checkbox"/>

• Attached by two rear fix bolts

Finger Plates



Article No.	Prod. Code	Description	Finish	Unit of Sale	Prod. Grp	
KX340	9KXALUM/340	300x75	SAA	10	5000	<input checked="" type="checkbox"/>
HQ1031	9HQFINGERPAA/1031	300x75 Plain	SAA	4 Bags	5000	<input type="checkbox"/>
HQ1033	9HQFINGERPAA/1033	300x75 Push	SAA	4 Bags	5000	<input type="checkbox"/>
HQ1035	9HQFINGERPAA/1035	300x75 Pull	SAA	4 Bags	5000	<input type="checkbox"/>

Signs



Article No.	Prod. Code	Description	Finish	Unit of Sale	Prod. Grp	
HQ1117/2	9HQFEMALEAA/1117	Self Adhesive Female	SAA	4 Bags	5001	<input type="checkbox"/>
HQ1118/4	9HQMALEAA/1118	Self Adhesive Male	SAA	4 Bags	5001	<input type="checkbox"/>

Cylinder/Door Pulls

Aluminium



Article No.	Prod. Code	Finish	Unit of Sale	Prod. Grp	
KX350	9KXALUM/350	SAA	10	5000	<input checked="" type="checkbox"/>
HQ1037/2	9HQCYLPULLAA/1037	SAA	4 Bags	5001	<input type="checkbox"/>

Door Stops

Boxed

Product Group 5000/5001



Article No.	Prod. Code	Description	Finish	Unit of Sale	Prod. Grp		
KX378	9KXALUM/378	Tubular 75mm	SAA	10	5000	<input checked="" type="checkbox"/>	A
KX379	9KXALUM/379	Skirting Mounted 65mm	SAA	10	5000	<input checked="" type="checkbox"/>	B
HQ1103/4	9HQSTOPAA/1103	Skirting Mounted 65mm	SAA	4 Bags	5001	<input type="checkbox"/>	
KX380	9KXALUM/380	Oval Shield	SAA	10	5000	<input checked="" type="checkbox"/>	C
KX480	9KXVIC/480	Oval Shield	PLB	5	5000	<input checked="" type="checkbox"/>	
HQ1101/4	9HQSTOPAA/1101	Oval Shield	SAA	4 Bags	5001	<input type="checkbox"/>	
HQ1667/4	9HQSTOPCP/1667	Oval Shield	CP	4 Bags	5001	<input type="checkbox"/>	
739 NP	9TQINPSDS/005	Spring 65mm	NP	10	5000	<input checked="" type="checkbox"/>	
HQ2077/4	9HQSTOPEB/2077	Spring 65mm	EB	4 Bags	5001	<input type="checkbox"/>	D
737WH L	9TQIWDS/005	PVC 35mm	White	30	5000	<input checked="" type="checkbox"/>	E
737WH S	9TQIWDS/010	PVC 25mm	White	30	5000	<input checked="" type="checkbox"/>	
737BL L	9TQIBDS/005	PVC 35mm	Black	30	5000	<input checked="" type="checkbox"/>	
737BL S	9TQIBDS/010	PVC 25mm	Black	30	5000	<input checked="" type="checkbox"/>	
HQ2075/4	9HQSTOPRUBBLK/2075	PVC 35mm	Black	4 Bags	5001	<input type="checkbox"/>	
HQ2073/4	9HQSTOPRUBWH/2073	PVC 35mm	White	4 Bags	5001	<input type="checkbox"/>	

Numerals



Article No.	Prod. Code	Description	Finish	Unit of Sale	Prod. Grp		
HQ1307/4	9HQNUMERALVIC/1307	Face Fix 75mm No.0	PLB	4 Bags	5001	<input type="checkbox"/>	
HQ1309/4	9HQNUMERALVIC/1309	Face Fix 75mm No.1	PLB	4 Bags	5001	<input type="checkbox"/>	
HQ1311/4	9HQNUMERALVIC/1311	Face Fix 75mm No.2	PLB	4 Bags	5001	<input type="checkbox"/>	
HQ1313/4	9HQNUMERALVIC/1313	Face Fix 75mm No.3	PLB	4 Bags	5001	<input type="checkbox"/>	
HQ1315/4	9HQNUMERALVIC/1315	Face Fix 75mm No.4	PLB	4 Bags	5001	<input type="checkbox"/>	
HQ1317/4	9HQNUMERALVIC/1317	Face Fix 75mm No.5	PLB	4 Bags	5001	<input type="checkbox"/>	
HQ1319/4	9HQNUMERALVIC/1319	Face Fix 75mm No.6	PLB	4 Bags	5001	<input type="checkbox"/>	
HQ1321/4	9HQNUMERALVIC/1321	Face Fix 75mm No.7	PLB	4 Bags	5001	<input type="checkbox"/>	
HQ1323/4	9HQNUMERALVIC/1323	Face Fix 75mm No.8	PLB	4 Bags	5001	<input type="checkbox"/>	
HQ1325/4	9HQNUMERALVIC/1325	Face Fix 75mm No.9	PLB	4 Bags	5001	<input type="checkbox"/>	
HQ1641/4	9HQNUMERALCP/1641	Face Fix 75mm No.0	CP	4 Bags	5001	<input type="checkbox"/>	
HQ1643/4	9HQNUMERALCP/1643	Face Fix 75mm No.1	CP	4 Bags	5001	<input type="checkbox"/>	
HQ1645/4	9HQNUMERALCP/1645	Face Fix 75mm No.2	CP	4 Bags	5001	<input type="checkbox"/>	
HQ1647/4	9HQNUMERALCP/1647	Face Fix 75mm No.3	CP	4 Bags	5001	<input type="checkbox"/>	
HQ1649/4	9HQNUMERALCP/1649	Face Fix 75mm No.4	CP	4 Bags	5001	<input type="checkbox"/>	
HQ1651/4	9HQNUMERALCP/1651	Face Fix 75mm No.5	CP	4 Bags	5001	<input type="checkbox"/>	
HQ1653/4	9HQNUMERALCP/1653	Face Fix 75mm No.6	CP	4 Bags	5001	<input type="checkbox"/>	
HQ1655/4	9HQNUMERALCP/1655	Face Fix 75mm No.7	CP	4 Bags	5001	<input type="checkbox"/>	
HQ1657/4	9HQNUMERALCP/1657	Face Fix 75mm No.8	CP	4 Bags	5001	<input type="checkbox"/>	
HQ1659/4	9HQNUMERALCP/1659	Face Fix 75mm No.9	CP	4 Bags	5001	<input type="checkbox"/>	

* 76mm, lacquered to reduce tarnishing



Kicking Plates

Aluminium



Article No.	Prod. Code	Description	Finish	Unit of Sale	Prod. Grp	
KX760	9KXKICK/760	750mm x 150mm	SAA	1	5000	<input checked="" type="checkbox"/>
KX761	9KXKICK/761	825mm x 150mm	SAA	1	5000	<input checked="" type="checkbox"/>
KX765	9KXKICK/765	750mm x 200mm	SAA	1	5000	<input checked="" type="checkbox"/>
KX766	9KXKICK/766	825mm x 200mm	SAA	1	5000	<input checked="" type="checkbox"/>
HQ1121/2	9HQKICKAA/1121	750mm x 152mm	SAA	2 Bags	5001	<input type="checkbox"/>

Brass



HQ1343/2	9HQKICKBR/1343	750mm x 152mm	PLB	2 Bags	5001	<input type="checkbox"/>
----------	----------------	---------------	-----	--------	------	--------------------------

Door Closers

Boxed

Product Group 205



Article No.	Description	Finish	Unit of Sale
AIDC5103SE	Power Size 3	CE	SE 1

Quality & Performance: Successfully type tested to all the requirements of BS EN 1154:1996 + A1:2002 4 8 3 1 13

CE Marked: 1121

Fire Safety: Included in a successful fire test to BS EN 1634 Part1: 2000. For use on a 2 hour fire door.

- Suitable for Door 950mm – Wide / 65kg – Weight • Adjustable Closing Speed
- Adjustable Latching Speed • Supplied for Use in Fig 1, Fig 61 and Fig 66 Application
- Snap On Arm for Easy Fitting • Silver Body Mechanism, Silver Armset and Bracket



AIDC5324SE	Power Size 2-4 by Template	CE	SE 1
------------	----------------------------	----	------

Quality & Performance: Successfully type tested to all the requirements of BS EN 1154:1996 + A1:2002 3 8 3 1 13

CE Marked: 1121-CPD-AD0019

Fire Safety: Included in a successful fire test to BS EN 1634 Part1: 2000. For use on a 2 hour fire door.

- Suitable for Door 950-1050mm – Wide / 85kg – Weight • Adjustable Closing Speed
- Adjustable Latching Speed • Supplied for Use in Fig 1, Fig 61 and Fig 66 Application
- Snap On Arm for Easy Fitting • Silver Body Mechanism, Silver Armset and Bracket
- Backcheck

Door Closers



ASSA ABLOY



Article No.	Prod. Code	Description	CE	Finish	Unit of Sale	Prod. Grp		
N8824BCSIL	9UNIONDC/003	Medium Duty with Backcheck Power Size 2-4	CE	SIL	1	5074	<input checked="" type="checkbox"/>	<input checked="" type="checkbox"/>

- Suitable for fire resistant doors and other internal doors
- Sizes EN 2-4 wind through adjustable



N8834SIL	9UNIONDC/002	CE Marked Door Closer	CE	SIL	1	5074	<input checked="" type="checkbox"/>	<input checked="" type="checkbox"/>
----------	--------------	-----------------------	----	-----	---	------	-------------------------------------	-------------------------------------

- Suitable for fire resistant doors and other internal doors
- Sizes EN 3-4, template selectable

Door Closers



DC30	9DORCON/010	Surface Fixing - Push Close	WE	1	5000	<input checked="" type="checkbox"/>	<input checked="" type="checkbox"/>
DC35	9DORCON/035	Surface Fixing - Push Close	SCP	1	5000	<input checked="" type="checkbox"/>	<input checked="" type="checkbox"/>
DC70	9DORCON/005	Chain Door Closer - Pull Close	EB	1			



Door Closer

Fixed CEF 3 Rack & Pinion Door



CE3F	9UNIONDC/008	CE	166mm	Silver	1	5074	<input type="checkbox"/>
------	--------------	----	-------	--------	---	------	--------------------------

- EN1154 size 3 CE Marked as Size 3 in all 3 fixing positions • Fire rated for timber (FD120) and metal (FD240)
- 10 year guarantee



ASSA ABLOY



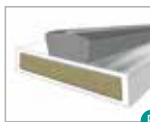

Intumescent Strips



Article No.	Description	Finish	Box Qty.
AF1504FOB	Fire Strip 15mm×4mm×2.1m 30 Minute	Brown	1 A
AF1504FOW	Fire Strip 15mm×4mm×2.1m 30 Minute	White	1
OJ790275	Fire Strip 10mm×4mm×2.1m 30 Minute	Brown	1
OJ790282	Fire Strip 10mm×4mm×2.1m 30 Minute	White	1

• Certifire approval • Passed at BS476 part 22 & 31.1 • Smoke seals to EN1634-3 • All seals are supplied with self adhesive backing tape

AF1504FSB	Fire & Smoke 15mm×4mm×2.1m 30 Minute	Brown	1 B
AF1504FSW	Fire & Smoke 15mm×4mm×2.1m 30 Minute	White	1
OJ790299	Fire & Smoke 10mm×4mm×2.1m 30 Minute	Brown	1
OJ790305	Fire & Smoke 10mm×4mm×2.1m 30 Minute	White	1

• Fire only seals are for use where no smoke sealing is required • Fire and smoke seals provide a safe and effective barrier against fire, cold smoke and hot gases

Emergency Exit Hardware

Boxed

Product Group 206

Article No.	Description	Finish	Pack Qty.
AIPB991SE	Reversible Panic Latch	CE	SE 1 B
AIPB992SE	Panic Bolt	CE	SE 1 C
AIPB993SE	Reversible Emergency Latch	CE	SE 1 D

Single point latch, vertical bolts or mortice nightlatch options:

- Supplied as Left Hand or Right Hand but can be reversed on-site • Tested for use on Fire Doors to EN 1634-1 (Check for details)
- Can be cut down on site for doors up to 1,300mm wide and 2,500mm high • Universal Keep for single doors and rebated double door applications
- Keep can be surface mounted or morticed into a timber frame on single door applications
- Adjustable top/bottom shoots of vertical bolts with ±5mm of adjustment
- Anti thrust device on vertical bolts prevents shoot bolt being forcibly retracted
- Vertical bolts supplied with easy clean socket and flat plate keep • All versions supplied with fixings for timber doors
- Available in SE – Powder coated silver (as standard) or SC – Satin Chrome plated to order • 240 hour salt spray tested



Draught Excluders

Product Codes Begin **9STORM** Product Group **5126**

Article No.	Description	Finish	Box Qty.
01SR0242057A	Around Door Sealing Kit	Alum	1
01SR0242057G	Around Door Sealing Kit	Gold	1
01SR0242057W	Around Door Sealing Kit	White	1
01SR0262057B	Slikseal Door Sealing Kit	Brown	1
01SR0262057W	Slikseal Door Sealing Kit	White	1
01SR0302057W	Bryseal Door Sealing Kit	White	1
02SR0190914A	Heavy Duty Bottom Door Brush Strip 914mm	Alum	1
02SR0190914G	Heavy Duty Bottom Door Brush Strip 914mm	Gold	1
02SR0192134A	Heavy Duty Bottom Door Brush Strip 7ft	Alum	1
02SR0200914B	PVC Bottom Door Brush Strip 914mm	Brown	1
02SR0200914W	PVC Bottom Door Brush Strip 914mm	White	1
04SR0010914A	Lowline Threshold 914mm	Alum	1
04SR0010914G	Lowline Threshold 914mm	Gold	1
04SR0040914A	Trimline Threshold Kit 914mm	Alum	1
04SR3330914A	SG100 Threshold 914mm	Alum	1
04SR3330914G	SG100 Threshold 914mm	Gold	1
05SR022005MB	Self Adhesive Foam 5m	Brown	1
05SR022005MW	Self Adhesive Foam 5m	White	1
05SR022015MW	Self Adhesive Foam 15m	White	1
05SR033005MB	EPDM E Profile 5m	Brown	1
05SR033005MW	EPDM E Profile 5m	White	1
05SR034005MB	EPDM P Profile 5m	Brown	1
05SR034005MW	EPDM P Profile 5m	White	1
05SR0363.5MBL	Extra Thick Rubber Foam 3.5m	Black	1
05SR0363.5MW	Extra Thick Rubber Foam 3.5m	White	1
06SR015B	Brush Letterplate No Flap	Brown	1
06SR015W	Brush Letterplate No Flap	White	1
06SR016B	Brush Letterplate With Flap	Brown	1
06SR016W	Brush Letterplate With Flap	White	1
07SR0130914A	32mm Rain Deflector 914mm	Alum	1
07SR0130914G	32mm Rain Deflector 914mm	Gold	1
18SR6820000RE	Outside Tap Cover		5



01SR0242057A Alum
01SR0242057G Gold
01SR0242057W White

- Excellent performance under severe weather conditions. Draught proofing strips bridge the gap between the door and the frame. Wind pressure increases the efficiency of the system.
- Quick and easy to fit.
- Can be used as a 'cold smoke seal'.

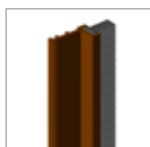

01SR0262057B Brown
01SR0262057W White

- Also suitable for outward opening and sliding sash windows.
- Lightweight draught excluder, with 5mm black polypropylene brush in PVC housing.
- Can be used as a 'cold smoke seal'.

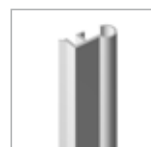
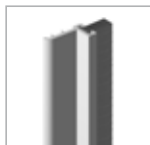

01SR0302057W White

- Also suitable for outward opening windows.
- Light and easy to use draught strip with one piece PVC 3/4" 'C' section.
- Paintable, wipe clean surface.



02SR0190914A Alum
02SR0190914G Gold
02SR0192134A Alum

- Simple, effective brush draught excluder with a 26mm polypropylene brush in a heavy duty aluminium carrier.
- Seals gaps 5mm-15mm and comes with pre drilled holes and fixing screws.
- Ideal for sliding, folding, hinged and garage doors.

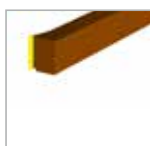

05SR022005MB Brown
05SR022005MW White
05SR022015MW White

- Seals gaps up to 3mm. Self adhesive. Wipe clean.
- Excellent memory, returns back to its original shape after compression.
- Ideal for gaps around doors and windows.



06SR015B Brown
06SR015W White

- Intermeshing, twin brush design.
- Quick and easy to fit, with pre-drilled fixing holes.
- Wipe clean finish.



02SR0200914B Brown
02SR0200914W White

- Simple, effective brush draught excluder with a 26mm polypropylene brush in a PVC carrier.
- Seals gaps 5mm-15mm and comes with pre drilled holes and fixing screws.
- Ideal for sliding, folding, hinged and garage doors.

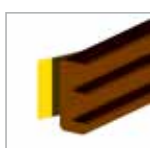

05SR033005MB Brown E
05SR033005MW White E

- Excellent quality long life self-adhesive EPDM rubber (ethylene propylene diene M-class rubber) draught strip.
- Seals gaps 1.5mm-3mm.
- Stretch resistant during fitting and in use.



06SR016B Brown
06SR016W White

- Intermeshing, twin brush design, with hinged flap to cover bristles.
- Quick and easy to fit, with pre-drilled fixing holes.
- Wipe clean finish.

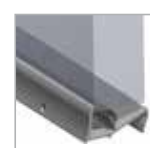

04SR0010914A Alum

- Excellent performance under severe weather conditions.
- Central nitrile rubber seal.
- Based on the tried, tested and original "Macclesfield Step" Design.



05SR034005MB Brown P
05SR034005MW White P

- Excellent quality long life self-adhesive EPDM rubber (ethylene propylene diene M-class rubber) draught strip.
- Seals gaps 1.5mm-3mm.
- Stretch resistant during fitting and in use.



07SR0130914A Alum
07SR0130914G Gold

- Intermeshing, twin brush design, with hinged flap to cover bristles.
- Quick and easy to fit, with pre-drilled fixing holes.
- Wipe clean finish.

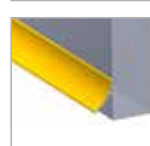

04SR3330914A Alum
04SR3330914G Gold

- Low profile threshold with concealed fixings.
- Central rubber seal.
- Suitable for inward or outward opening Doors.

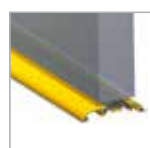

05SR0363.5MBL Black
05SR0363.5MW White

- Excellent quality long life self-adhesive EPDM rubber (ethylene propylene diene M-class rubber) draught strip.
- Seals gaps 1.5mm-3mm.
- Stretch resistant during fitting and in use.



18SR6820000RE

- Insulates outdoor taps to prevent freezing when the temperature drops below zero.
- Quick and easy to fit.
- Quick and easy to remove.

Window Accessories



900A Casement Stays

Article No.	Prod. Code	Description Size /	No. of screws Screw size /	Finish	Unit of Sale	Prod. Group	
900A 8BRN	9BRNZKCS/005	200mm	8g / 4	Brown	10	5000	<input checked="" type="checkbox"/>
900A 10BRN	9BRNZKCS/010	250mm	8g / 4	Brown	10	5000	<input checked="" type="checkbox"/>
900A 250EXBL	9EXBLCS/005	250mm	8g / 4	Black	10	5000	<input checked="" type="checkbox"/>
900A 12GREY	9GREYKCS/015	300mm	8g / 4	Grey	10	5000	<input checked="" type="checkbox"/>

561 Curly Tail Casement Stays



561 10	9CSTAY/036	250mm	8g / 4	EXB	10	5000	<input checked="" type="checkbox"/>
HQ1921/4	9HQCSTAYEXB/1921	250mm	8g / 4	EXB	4 Bags	5001	<input type="checkbox"/>

Aluminium Casement Stays – Extruded



Article No.	Prod. Code	Description Size /	Finish	Unit of Sale	Prod. Group	
KX385	9KXALUM/385	200mm	SAA	25	5000	<input checked="" type="checkbox"/>
KX386	9KXALUM/386	250mm	SAA	25	5000	<input checked="" type="checkbox"/>
HQ1105/4	9HQCSTAYAA/1105	200mm	SAA	4 Bags	5001	<input type="checkbox"/>
HQ1107/4	9HQCSTAYAA/1107	250mm	SAA	4 Bags	5001	<input type="checkbox"/>
HQ1109/4	9HQCSTAYAA/1109	300mm	SAA	4 Bags	5001	<input type="checkbox"/>

Brass Casement Stays



KX486	9KXVIC/486	250mm	PLB	5	5000	<input checked="" type="checkbox"/>
KX487	9KXVIC/487	300mm	PLB	5	5000	<input checked="" type="checkbox"/>
KX460	9KXVIC/460	250mm	PLB	2	5000	<input checked="" type="checkbox"/>
HQ1277/4	9HQCSTAYVIC/1277	250mm	PLB	4 Bags	5001	<input type="checkbox"/>
HQ1621/2	9HQCSTAYCP/1621	250mm	PC	4 Bags	5001	<input type="checkbox"/>
HQ1713/4	9HQCSTAYSN/1713	250mm	SNP	4 Bags	5001	<input type="checkbox"/>



Black Antique Casement Stays



Article No.	Prod. Code	Description	Size / Finish	Unit of Sale	Prod. Group		
KX985	9KXANTIQUE/985	200mm Curly Tail	PLB	10	5000	<input checked="" type="checkbox"/>	A
KX986	9KXANTIQUE/986	250mm Curly Tail	PLB	5	5000	<input checked="" type="checkbox"/>	
KX987	9KXANTIQUE/987	250mm Solid	B/ANT	5	5000	<input checked="" type="checkbox"/>	B
HQ1479/2	9HQCSTAYBANT/1479	250mm Curly Tail	B/ANT	2 Bags	5001	<input type="checkbox"/>	
HQ1477/2	9HQCSTAYBANT/1477	250mm Solid	B/ANT	2 Bags	5001	<input type="checkbox"/>	



890 Casement Fasteners

Article No.	Prod. Code	Description	Size / No. of screws	Screw size / Finish	Unit of Sale	Prod. Group	
890 WH	9WHITEKWPCF/005	Wedge Plate	8g/4	White	5	5000	<input checked="" type="checkbox"/>



521 Casement Fasteners

HQ1925/4	9HQCFASTEHB/1925	Hook/Mortice Plate	8g/4	EXB	4 Bags	5001	<input type="checkbox"/>
----------	------------------	--------------------	------	-----	--------	------	--------------------------



Aluminium Casement Fasteners

HQ1111/4	9HQCFASTAA/1111	Wedge Plate	8g/4	SAA	4 Bags	5001	<input type="checkbox"/>
----------	-----------------	-------------	------	-----	--------	------	--------------------------



Brass Casement Fasteners



Article No.	Prod. Code	Description	Size / Finish	Unit of Sale	Prod. Group		
KX462	9KXVIC/462	Night Vent, Wedge Plate	PLB	5	5000	<input checked="" type="checkbox"/>	A
HQ1281/4	9HQCFASTVIC/1281	Hook/Mortice Plate	PLB	4 Bags	5001	<input type="checkbox"/>	
HQ1623/4	9HQCFASTCP/1623	Hook/Mortice Plate	PC	4 Bags	5001	<input type="checkbox"/>	



Window Accessories

Black Antique Casement Stays



Article No.	Prod. Code	Description	Size /	Finish	Unit of Sale	Prod. Group	
KX988	9KXANTIQUE/988	Hook/Mortice Plate, Curly Tail		B/ANT	5	5000	<input checked="" type="checkbox"/> A
HQ1483/2	9HQCFASBANT/1483	Hook/Mortice Plate, Curly Tail		B/ANT	2 Bags	5001	<input type="checkbox"/>

No.1 Fitch Fasteners



Article No.	Prod. Code	No. of screws /	Screw size /	Finish	Unit of Sale	Prod. Group	
NO.1 ZP	9TQIFFZP/005	8g / 4		ZP	10	5000	<input checked="" type="checkbox"/>

A1 Sash Fasteners



A1 SILVER	9TQITSSF/010	8g / 4	Silver	10	5000	<input checked="" type="checkbox"/>
A1 GOLD	9TQITGSF/010	8g / 4	Gold	10	5000	<input checked="" type="checkbox"/>
HQ1927/4	9HQSASBZ/1927	8g / 4	Silver	4 Bags	5001	<input type="checkbox"/>
HQ1929/4	9HQSASHEB/1929	8g / 4	Gold	4 Bags	5001	<input type="checkbox"/>

Brass Fitch Fasteners



Article No.	Prod. Code	Finish	Unit of Sale	Prod. Group	
KX570	9KXVIC/570	PLB	10	5000	<input checked="" type="checkbox"/>
HQ1287/4	9HQFITCHVIC/1287	PLB	4 Bags	5001	<input type="checkbox"/>



Brass Sash Fasteners



A

Article No.	Prod. Code	Description	Size /	Finish	Unit of Sale	Prod. Group		
KX438	9KXVIC/438	Brighton Design		PLB	10	5000	<input checked="" type="checkbox"/>	A
HQ1285/4	9HQSASHVIC/1285	Brighton Design		PLB	4 Bags	5001	<input type="checkbox"/>	
HQ1629/4	9HQSASHCP/1629	Brighton Design		PC	4 Bags	5001	<input type="checkbox"/>	



Brass Fanlight Catches

KX429	9KXVIC/429	Square Catch w / Ring		PLB	4	5000	<input checked="" type="checkbox"/>	
-------	------------	-----------------------	--	-----	---	------	-------------------------------------	--

Brass Sash Lifts



A

KX449	9KXVIC/449	Architectural		PLB	20	5000	<input checked="" type="checkbox"/>	A
KX539	9KXVIC/539	Architectural		PC	20	5000	<input checked="" type="checkbox"/>	
HQ1255/4	9HQSASHVIC/1255	Architectural		PLB	4 Bags	5001	<input type="checkbox"/>	
HQ1609/4	9HQSASHCP/1609	Architectural		PC	4 Bags	5001	<input type="checkbox"/>	

Abracs

Cut & Grind



Product Group 94

Abracs are proud to supply only the highest quality ranges of abrasive cutting and grinding discs. Discs are available for use on mild steel or iron, stone and building materials, stainless steel, cast iron, aluminium and foundry materials. All Abracs discs are subject to stringent quality control procedures and meet all required safety standards.

General Information

Markings on abrasive disc labels



The safe use of abrasive cutting and grinding discs: -

It is very important to always comply with all safety and accident prevention regulations when using abrasive cutting and grinding discs. All Abracs discs are marked with the appropriate safety information pictograms.

Always wear a dust mask. Always wear ear protection. Always wear safety goggles or glasses. Always wear safety gloves. Always observe ALL safety instructions.

Grade explanation. Example: A 30 S BF

A: Indicates the abrasive grain (A=Aluminium Oxide for metal, C=Silicon Carbide for stone)

30: Indicates the grit size. The higher the number, the finer the grade.

S: Indicates the hardness of the disc.

BF: Indicates the nature of the bond. "BF" stands for reinforced bond.

Type explanation: Abrasive discs are available in several different types. The most common being F41 (Flat centre), F42 (DPC centre for cutting) and F27 (DPC centre for grinding)

Operating speeds: Maximum operating speeds are marked clearly on all Abracs discs and should never be exceeded.

Full training on the safe use and fitting of abrasive wheels is available from Abracs. Please speak to our Head Office or your Area Manager for full details on available courses.



Cutting & Grinding - Abracs' signature product range, offers one of the most comprehensive and highest quality abrasive disc ranges available on the UK market. With an extensive range of Cutting, Grinding, Extra Thin and Specialist discs available for use on a wide range of applications. All Abracs discs are subject to rigorous quality control procedures and are manufactured to European safety standards. Abracs range into 3 star and 5 star quality levels & application types to make selecting the right product as easy as possible.



Cut & Grind - Proflex



Product Group 94

Specification	Grade	Max Rpm	Box Qty	Outer Qty	Prod. Code
100mm x 3mm x 16mm DPC METAL	A30S4BF	15200	25	400	PF10030DM
100mm x 3mm x 16mm DPC STONE	C30S4BF	15200	25	400	PF10030DS
100mm x 3mm x 16mm FLAT METAL	A30S4BF	15200	25	400	PF10030FM
100mm x 3mm x 16mm FLAT STONE	C30S4BF	15200	25	400	PF10030FS
100mm x 6mm x 16mm DPC METAL	A30S4BF	15200	25	200	PF10060DM
115mm x 3mm x 22mm DPC METAL	A30S4BF	13200	25	200	PF11530DM
115mm x 3mm x 22mm DPC STONE	C30S4BF	13200	25	200	PF11530DS
115mm x 3mm x 22mm FLAT METAL	A30S4BF	13200	25	200	PF11530FM
115mm x 3mm x 22mm FLAT STONE	C30S4BF	13200	25	200	PF11530FS
115mm x 6mm x 22mm DPC METAL	A30S4BF	13200	25	100	PF11560DM
115mm x 6mm x 22mm DPC STONE	A30S4BF	13200	25	100	PF11560DS
125mm x 3mm x 22mm DPC METAL	A30S4BF	12200	25	200	PF12530DM
125mm x 3mm x 22mm DPC STONE	C30S4BF	12200	25	200	PF12530DS
125mm x 3mm x 22mm FLAT METAL	A30S4BF	12200	25	200	PF12530FM
125mm x 3mm x 22mm FLAT STONE	C30S4BF	12200	25	200	PF12530FS
125mm x 6mm x 22mm DPC METAL	A30S4BF	12200	25	100	PF12560DM
180mm x 3mm x 22mm DPC METAL	A30S4BF	8600	25	100	PF17830DM
180mm x 3mm x 22mm FLAT METAL	A30S4BF	8600	25	100	PF17830FM
180mm x 3mm x 22mm FLAT STONE	C30S4BF	8600	25	100	PF17830FS
180mm x 6mm x 22mm DPC METAL	A30S4BF	8600	25	50	PF17860DM
230mm x 3mm x 22mm DPC METAL	A30S4BF	6600	25	50	PF23030DM
230mm x 3mm x 22mm DPC STONE	C30S4BF	6600	25	50	PF23030DS
230mm x 3mm x 22mm FLAT METAL	A30S4BF	6600	25	50	PF23030FM
230mm x 3mm x 22mm FLAT STONE	C30S4BF	6600	25	50	PF23030FS
230mm x 6mm x 22mm DPC METAL	A30S4BF	6600	25	50	PF23060DM
230mm x 6mm x 22mm FLAT STONE	C30S4BF	6600	25	50	PF23060DS
300mm x 3.0mm x 20mm FLAT METAL	A30S4BF	5100	25	25	PF3003020FM
300mm x 3.0mm x 20mm FLAT STONE	C30S4BF	5100	25	25	PF3003020FS
355mm x 2.8 x 25.4mm FLAT METAL	A24RBF	4000	25	25	PF3502825FM

Abracs

Cut & Grind - Phoenix II



Product Group 94

Specification	Grade	Max Rpm	Box Qty	Outer Qty	Prod.Code
100mm x 3mm x 16mm DPC METAL	A30S4BF	15200	25	400	PH10030DM
100mm x 3mm x 16mm FLAT METAL	A30S4BF	15200	25	400	PH10030FM
100mm x 6.5 x 16mm DPC METAL	A24S4BF	15200	25	200	PH10060DM
115mm x 3mm x 22mm DPC METAL	A30S4BF	13200	25	200	PH11530DM
115mm x 3mm x 22mm FLAT METAL	A30S4BF	13200	25	200	PH11530FM
115mm x 3mm x 22mm FLAT STONE	C30S4BF	13200	25	200	PH11530FS
115mm x 6.5 x 22mm DPC METAL	A24S4BF	13200	25	100	PH11560DM
115mm x 6.5 x 22mm DPC STONE	A24S4BF	13200	25	100	PH11560DS
125mm x 3mm x 22mm DPC METAL	A30S4BF	12200	25	200	PH12530DM
125mm x 3mm x 22mm FLAT METAL	A30S4BF	12200	25	200	PH12530FM
125mm x 6.5 x 22mm DPC METAL	A24S4BF	12200	25	100	PH12560DM
178mm x 3mm x 22mm DPC METAL	A30S4BF	8600	25	100	PH17830DM
178mm x 3mm x 22mm FLAT METAL	A30S4BF	8600	25	100	PH17830FM
178mm x 6.8 x 22mm DPC METAL	A24S4BF	8600	25	50	PH17860DM
230mm x 3mm x 22mm DPC METAL	A30S4BF	6600	25	50	PH23030DM
230mm x 3mm x 22mm DPC STONE	C30S4BF	6600	25	50	PH23030DS
230mm x 3mm x 22mm FLAT METAL	A30S4BF	6600	25	50	PH23030FM
230mm x 3mm x 22mm FLAT STONE	C30S4BF	6600	25	50	PH23030FS
230mm x 6.8 x 22mm DPC METAL	A24S4BF	6600	25	50	PH23060DM
230mm x 6.8 x 22mm DPC STONE	A24S4BF	6600	25	50	PH23060DS
300mm x 3.5mm x 20mm FLAT METAL	A30S4BF	5100	25	25	PH3003020FM
300mm x 4mm x 20mm FLAT STONE	C30S4BF	5100	25	25	PH3003020FS
300mm x 3.5mm x 22mm FLAT METAL	A30S4BF	5100	25	25	PH3003022FM
300mm x 4mm x 22mm FLAT STONE	C30S4BF	5100	25	25	PH3003022FS
300mm x 3.5 x 25.4mm FLAT METAL	A30S4BF	5100	25	25	PH3003025FM
350mm x 2.5 x 25.4mm METAL	A36SBF	4000	25	25	PH3502525FM
350mm x 3.2 x 25.4mm FLAT STONE	C30S4BF	4000	25	25	PH3503025FS
350mm x 3.5mm x 22mm FLAT MET	A30S4BF	5500	25	25	PH3503522FM
350mm x 3.5 x 25.4mm FLAT MET	A24S4BF	4370	25	25	PH3503525FM
350mm x 4.0mm x 20mm FLAT METAL	A24RBF	5500	25	25	PH3504020FM



Extra Thin INOX Cutting Discs



Product Group 94

Extra Thin Cutting discs are the fastest and most efficient blades for cutting both mild steel and stainless steel. They have been designed specifically for special cutting applications where speed, efficiency and accuracy are all important. EXTRA THIN do not contain Fe, S or Cl (Iron, sulphur chlorine) and are suitable for cutting stainless steel, construction steel, special material samples and are suitable for use in the petro-chemical, nuclear and food industries. Manufactured to European safety standards and supplied in attractive display boxes ideal for any trade counter or shop display. Abracs Extra Thin discs are available in both our Phoenix and Proflex range.

Key Features:

- Extremely fast cutting
- Minimum effort required
- Iron, Sulphur and chlorine free
- Precision cutting to the millimetre
- Safer and easier to use than a standard disc
- Low vibration
- Less burning than with a standard disc
- Suitable for cutting mild steel and stainless steel
- Professional performance and long life



Proflex Extra Thin are an incredibly good value product with an exceptional cost per cut ratio. Manufactured to European quality standards, a high performance disc designed for speed, accuracy and long life. The Proflex Extra Thin Discs do not contain iron, sulphur or chlorine so are suitable for stainless steel cutting applications.

Specification	Grade	Max Rpm	Box Qty	Prod. Code
100mm x 1.0mm INOX	A60TBF	15200	100	PFET10010FI
115mm x 1.0mm INOX	A60TBF	13300	10	PFET11510FI
115X1.0X22MM INOX	A60TBF	13300	25	PFET11510FI25
115mm x 1.6mm INOX	A60TBF	13300	100	PFET11516FI
125mm x 1.0mm INOX	A60RBF	12200	100	PFET12510FI
125mm x 1.6mm INOX	A60RBF	12200	100	PFET12516FI
230mm x 1.8mm INOX	A60RBF	6600	25	PFET23018FI



The Phoenix II discs are a signature product. A superior quality European manufactured range of extra thin cutting discs produced to O.S.A. Safety standards. Extremely fast and precise cutting with minimal effort required. Phoenix discs have been developed for precision cutting sheet metal and with strengthened core stability for reduced vibration. Phoenix Extra Thin Discs do not contain iron, sulphur or chlorine so are suitable for stainless steel cutting applications.

Specification	Grade	Max Rpm	Box Qty	Outer Qty	Prod. Code
50mm x 1.0mm x 10mm	20A60RBF	30560	25	100	PH05010FI
75mm x 1.0mm x 10mm	A46TBF	20400	25	100	PH07510FI
75mm x 1.6mm x 10mm	A46TBF	20400	25	100	PH07516FI
75mm x 2.0mm x 10mm	A46TBF	20400	25	100	PH07520FI
100mm x 1.0mm x 16mm	20A60RBF	15200	50	50	PHET10010FI
100mm x 1.2mm x 16mm	20A46RBF	15200	50	50	PHET10012FI
100mm x 1.6mm x 16mm	20A46RBF	15200	50	50	PHET10016FI
115mm x 1.0mm x 22mm	20A46RBF	13300	50	50	PHET11510FI
115mm x 1.2mm x 22mm	20A46RBF	13300	50	50	PHET11512FI
115mm x 1.6mm x 22mm	20A46RBF	13300	50	50	PHET11516FI
125mm x 1.0mm x 22mm	20A46RBF	12200	50	50	PHET12510FI
125mm x 1.2mm x 22mm	20A46RBF	12200	50	50	PHET12512FI
125mm x 1.6mm x 22mm	20A46RBF	12200	50	50	PHET12516FI
178mm x 1.6mm x 22mm	20A46RBF	8600	50	50	PHET17816FI
230mm x 1.8mm x 22mm	20A46RBF	6600	50	50	PHET23018FI

Abracs

Extra Thin INOX Cutting Discs



Product Group 94



Phoenix Silver is a European manufactured disc range free from Iron, Sulphur and Chlorine. Similar to the Extra Thin Cutting Discs range, the Phoenix Silver range of cutting and grinding discs is designed specifically for use on stainless steel as these specialist discs do not leave residue or contamination. Phoenix Ali are expert quality, heavy duty specialist Cutting and Grinding Discs designed specifically for use on aluminium and other non-ferrous materials. The composition of this specialist disc is designed so it is highly resistant to clogging and will protect against overheating the material. Both Discs are Made to O.S.A. Safety standards and marked with EN12413.

Specification	Grade	Max Rpm	Box Qty	Prod. Code
ALI 115mm x 1.0mm x 22mm	54A30RBF	13200	25	PHA11510FA
ALI 115mm x 3mm x 22mm	54A30RBF	13200	25	PHA11530DA
ALI 115mm x 7mm x 22mm	54A30RBF	13200	25	PHA11570DA
ALI 230mm x 3mm x 22mm	54A30RBF	6600	25	PHA23030DA
ALI 230mm x 7mm x 22mm	54A30RBF	6600	25	PHA23070DA
SILVER 100mm x 3mm x 16mm DPC INOX	20A24P4BF	15200	25	PHS10030DI
SILVER 115mm x 3mm x 22mm DPC INOX	20A24P4BF	13200	25	PHS11530DI
SILVER 115mm x 6.5 x 22mm DPC INOX	20A24P4BF	13200	25	PHS11560DI
SILVER 125mm x 3mm x 22mm DPC INOX	20A24P4BF	12200	25	PHS12530DI
SILVER 125mm x 6.5 x 22mm DPC INOX	20A24P4BF	12200	25	PHS12560DI
SILVER 178mm x 3mm x 22mm DPC INOX	20A24P4BF	8600	25	PHS17830DI
SILVER 178mm x 6.8 x 22mm DPC INOX	20A24P4BF	8600	25	PHS17860DI
SILVER 230mm x 3mm x 22mm DPC INOX	20A24P4BF	6600	25	PHS23030DI
SILVER 230mm x 6.8 x 22mm DPC INOX	20A24P4BF	6600	25	PHS23060DI
SILVER 350mm x 2.8 x 25.4mm FLAT INOX	20A24P4BF	4000	25	PHS3502825FI

Multi Function Pin Spinner



Product Group 94

Versatile & multi-functional pin spanner with an adjustable head making it suitable for any size of grinder. This product incorporates a shaped hole which can be used as a wrench to unscrew and fasten 10mm-19mm bolts as well as a flat handle base that can be used as a screwdriver.



Specification	Box Qty	Outer Qty	Prod. Code
MULTI-FUNCTION PIN SPANNER	1	10	ABSPADJ



Hybrid Discs



Product Group 94



Designed for increasing productivity, maximising output and increasing work site safety. The new Abracs "Hybrids" product range consist of the "5in1 MAXI" disc for cutting virtually all materials and the "3in1 MULTI" disc for cutting, grinding and finishing applications

Specification	Grade	Max. Rpm	Box Qty	Prod. Code
5in1 MAXI DISC 115 X 1.6 X 22MM FLAT	A36RBF	13200	50	HY11516FM
3in1 MULTI DISC 115 X 2.5 X 22MM DPC	A36SBF	13200	25	HY11525DM

Flap Discs



Product Group 94



Premium quality flap discs are engineered for ultimate performance stock removal, blending and finishing. The lightweight fibreglass backing absorbs vibration and makes this product incredibly strong and durable. All Abracs flap discs are extremely long life & suitable for a full range of metal applications. Manufactured to O.S.A. Safety standards.

Specification	Max. Rpm	Box Qty	Outer Qty	Prod. Code
115mm x 40g AL/OX	13200	25	100	ABFA115B040
115mm x 60g AL/OX	13200	25	100	ABFA115B060
115mm x 80g AL/OX	13200	25	100	ABFA115B080
115mm x 120g AL/OX	13200	25	100	ABFA115B120
100mm x 40g ZIRCONIUM	15300	25	100	ABFZ100B040
100mm x 60g ZIRCONIUM	15300	25	100	ABFZ100B060
100mm x 80g ZIRCONIUM	15300	25	100	ABFZ100B080
100mm x 120g ZIRCONIUM	15300	25	100	ABFZ100B120
115mm x 40g ZIRCONIUM	13300	25	100	ABFZ115B040
115mm x 60g ZIRCONIUM	13300	25	100	ABFZ115B060
115mm x 80g ZIRCONIUM	13300	25	100	ABFZ115B080
115mm x 120g ZIRCONIUM	13300	25	100	ABFZ115B120
125mm x 40g ZIRCONIUM	12250	25	100	ABFZ125B040
125mm x 60g ZIRCONIUM	12250	25	100	ABFZ125B060
125mm x 80g ZIRCONIUM	12250	25	100	ABFZ125B080
125mm x 120g ZIRCONIUM	12250	25	100	ABFZ125B120
180mm x 40g ZIRCONIUM	8500	25	100	ABFZ180B040
180mm x 60g ZIRCONIUM	8500	25	100	ABFZ180B060
180mm x 80g ZIRCONIUM	8500	25	100	ABFZ180B080
115mm BROWN (COARSE)	13280	10	10	ABPOBROWN
115mm GREEN (FINE)	13280	10	10	ABPOGREEN
115mm MAROON (MEDIUM)	13280	10	10	ABPOMAROON

Abracs

Fibre Sanding Discs



Product Group 94



Fibre discs feature a full resin bond system with heavy-duty fibre backing for increased strength, durability and tear resistance. Manufactured to O.S.A. Safety standards. long life and high performance all come as standard.

Specification	Max Rpm	Box Qty	Outer Qty	Prod. Code
100mm x 24 grit AL/OX	15300	25	25	ABFD100024A
100mm x 24 grit ZIRC.	15300	25	25	ABFD100024Z
100mm x 36 grit AL/OX	15300	25	25	ABFD100036A
100mm x 36 grit ZIRC.	15300	25	25	ABFD100036Z
100mm x 60 grit AL/OX	15300	25	25	ABFD100060A
100mm x 60 grit ZIRC.	15300	25	25	ABFD100060Z
100mm x 80 grit AL/OX	15300	25	25	ABFD100080A
100mm x 80 grit ZIRC.	15300	25	25	ABFD100080Z
100mm x 120grit AL/OX	15300	25	25	ABFD100120A
100mm x 120 grit ZIRC	15300	25	25	ABFD100120Z
115mm x 24 grit AL/OX	13300	25	25	ABFD115024A
115mm x 24 grit ZIRC.	13300	25	25	ABFD115024Z
115mm x 36 grit AL/OX	13300	25	25	ABFD115036A
115mm x 36 grit ZIRC.	13300	25	25	ABFD115036Z
115mm x 60 grit AL/OX	13300	25	25	ABFD115060A
115mm x 60 grit ZIRC.	13300	25	25	ABFD115060Z
115mm x 80 grit AL/OX	13300	25	25	ABFD115080A
115mm x 80 grit ZIRC.	13300	25	25	ABFD115080Z
115mm x 120grit AL/OX	13300	25	25	ABFD115120A
115mm x 120 grit ZIRC	13300	25	25	ABFD115120Z
125mm x 24 grit AL/OX	12200	25	25	ABFD125024A
125mm x 24 grit ZIRC.	12200	25	25	ABFD125024Z
125mm x 36 grit AL/OX	12200	25	25	ABFD125036A
125mm x 36 grit ZIRC.	12200	25	25	ABFD125036Z
125mm x 60 grit AL/OX	12200	25	25	ABFD125060A
125mm x 60 grit ZIRC.	12200	25	25	ABFD125060Z
125mm x 80 grit AL/OX	12200	25	25	ABFD125080A
125mm x 80 grit ZIRC.	12200	25	25	ABFD125080Z
125mm x 120grit AL/OX	12200	25	25	ABFD125120A
125mm x 120 grit ZIRC	12200	25	25	ABFD125120Z
178mm x 24 grit AL/OX	8500	25	25	ABFD178024A
178mm x 24 grit ZIRC.	8500	25	25	ABFD178024Z
178mm x 36 grit AL/OX	8500	25	25	ABFD178036A
178mm x 36 grit ZIRC.	8500	25	25	ABFD178036Z
178mm x 60 grit AL/OX	8500	25	25	ABFD178060A
178mm x 60 grit ZIRC.	8500	25	25	ABFD178060Z
178mm x 80 grit AL/OX	8500	25	25	ABFD178080A
178mm x 80 grit ZIRC.	8500	25	25	ABFD178080Z
178mm x 120grit AL/OX	8500	25	25	ABFD178120A
178mm x 120 grit ZIRC	8500	25	25	ABFD178120Z



Backing Pads



Product Group 94

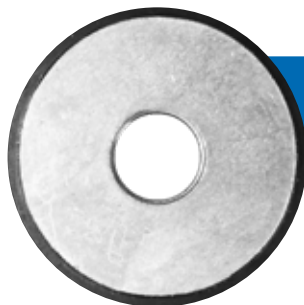

Abracs Backing Pads are manufactured from premium nylon compound to give maximum flexibility and support along with long life. Abracs Backing Pads are suitable for fibre discs and semi-flexible grinding discs.

Specification	Max Rpm	Box Qty	Outer Qty	Prod.Code
100mm x M10 1.5mm	15300	1	1	PHBP100101.5
115mm x M14	13300	1	1	PHBP11514
125mm x M14	12200	1	1	PHBP12514
178mm x M14	8500	1	1	PHBP17814

Poly Discs



Product Group 94



Abracs ultimate performance Poly Discs have a unique structure and synthetic resin coating which enables effective removal of rust, paint, thermal blueing and other contaminants. The lightweight fibreglass backing absorbs vibration and makes this product incredibly strong and durable. The design of these unique products ensures a minimal risk of scratching the work piece. Suitable for a wide range of materials. For use on angle grinders.

Specification	Max Rpm	Box Qty	Outer Qty	Prod.Code
115mm - BLACK	13200	24	24	ABPOLY115
115mm - BLUE	13200	24	24	ABPOLY115B

Hand Pads



Product Group 94



Abracs Non-Woven Hand Pads provide consistent surface preparation. Ideal for cleaning a wide range of applications and specially designed to resist loading, prolonging pad life. Tightly woven for consistent action without compromising durability. Flexible construction is ideal for grooves, scratch in channels and other hard to reach areas. Available in 4 different levels of coarseness for different applications.

Specification	Grade	Box Qty	Outer Qty	Prod.Code
NON WOVEN PAD BROWN (COARSE)	A0150	10	300	ABFHPBROWN
NON WOVEN PAD GREEN (GENERAL PURPOSE)	A0240	10	300	ABFHPGREEN
NON WOVEN PAD GREY (FINE)	SC1000	10	300	ABFHPGREY
NON WOVEN HAND PAD MAROON(MEDIUM)	A0400	10	300	ABFHPMAROON

Abracs

Spindle Mounted Flap Wheels



Product Group 94

Abracs range of Spindle Mounted Flap Wheels offer a superb combination of performance & versatility. Available in a broad range of sizes, materials and grades making them suitable for virtually all applications. All products are mounted on a 6mm spindle making them suitable for electric drills and air tools.

3PC FLAP WHEEL PACK



Specification	Max. Rpm	Box Qty	Outer Qty	Prod. Code
25MMX15MMX40/80/120G	16500	1	250	FWPK325
30MMX20MMX40/80/120G	16500	1	250	FWPK330
40MMX20MMX40/80/120G	12500	1	125	FWPK340
50MMX20MMX40/80/120G	10000	1	125	FWPK350
60MMX30MMX40/80/120G	8300	1	80	FWPK360
80MMX30MMX40/80/120G	6200	1	40	FWPK380

FLAP WHEEL



25mm x 15mm x 40grit	16500	10	200	PHFWSA2515040
25mm x 15mm x 60grit	16500	10	200	PHFWSA2515060
25mm x 15mm x 80grit	16500	10	200	PHFWSA2515080
25mm x 15mm x 120grit	16500	10	200	PHFWSA2515120
30mm x 20mm x 40grit	16500	10	200	PHFWSA3020040
30mm x 20mm x 60grit	16500	10	200	PHFWSA3020060
30mm x 20mm x 80grit	16500	10	200	PHFWSA3020080
30mm x 20mm x 120grit	16500	10	200	PHFWSA3020120
40mm x 20mm x 40grit	12500	10	200	PHFWSA4020040
40mm x 20mm x 60grit	12500	10	200	PHFWSA4020060
40mm x 20mm x 80grit	12500	10	200	PHFWSA4020080
40mm x 30mm x 40grit	12500	10	200	PHFWSA4030040
40mm x 30mm x 60grit	12500	10	200	PHFWSA4030060
40mm x 30mm x 80grit	12500	10	200	PHFWSA4030080
50mm x 20mm x 40grit	10000	10	200	PHFWSA5020040
50mm x 20mm x 60grit	10000	10	200	PHFWSA5020060
50mm x 20mm x 80grit	10000	10	200	PHFWSA5020080
50mm x 30mm x 40grit	10000	10	200	PHFWSA5030040
50mm x 30mm x 60grit	10000	10	200	PHFWSA5030060
50mm x 30mm x 80grit	10000	10	200	PHFWSA5030080
50mm x 40mm x 40grit	10000	10	200	PHFWSA5040040
50mm x 40mm x 60grit	10000	10	200	PHFWSA5040060
50mm x 40mm x 80grit	10000	10	200	PHFWSA5040080
60mm x 30mm x 60grit	8300	10	200	PHFWSA6030060
60mm x 30mm x 80grit	8300	10	200	PHFWSA6030080
60mm x 40mm x 40grit	8300	10	200	PHFWSA6040040
60mm x 40mm x 60grit	8300	10	200	PHFWSA6040060
60mm x 40mm x 80grit	8300	10	200	PHFWSA6040080
80mm x 30mm x 40grit	6200	10	200	PHFWSA8030040
80mm x 30mm x 60grit	6200	10	200	PHFWSA8030060
80mm x 30mm x 80grit	6200	10	200	PHFWSA8030080

MIXED FLAP WHEEL DISPLAY PACK



50pc MIXED FLAP WHEEL DISPLAY PACK	various	1	1	PHFWSAMIX50
------------------------------------	---------	---	---	-------------



Diamond Blades



Product Group 94

Abracs specialise in ultimate performance, expert quality Diamond Blade design and manufacture. Abracs have a comprehensive range of innovative Diamond Blade solutions for all industrial & construction market needs. Developed with over 25 years market expertise. Abracs precision manufacture and modern quality control methods allow Abracs to control and regulate the variables that affect blade life, quality of cut and product performance. Available in 3 quality levels in ranges designed to specialise across all application types.

DIAMOND BLADE TRADE



Specification	Max Rpm	Box Qty	Seg Height	Prod. Code
115mm x 10mm x 22mm	13200	1	10mm	ABDD115M
230mm x 10mm x 22mm	6600	1	10mm	ABDD230M
300mm x 10mm x 20mm	5100	1	10mm	ABDD30020M

DIAMOND BLADE PRO



Specification	Max Rpm	Box Qty	Seg Height	Prod. Code
115mm x 10mm x 22mm	13200	1	10mm	ABDT115M
230mm x 10mm x 22mm	6600	1	10mm	ABDT230M
300mm x 10mm x 20mm	5100	1	10mm	ABDT30020M

MORTAR/BRICK RAKING BLADE



Specification	Max Rpm	Box Qty	Seg Height	Prod. Code
115mm x 6.5mm x 22mm	13300	1	7mm	ABDBTPH115

TILE & PORCELAIN CUTTING BLADE



Specification	Max Rpm	Box Qty	Seg Height	Prod. Code
115mm x 1.2mm x 22mm	13300	1	10mm	ABDCR115
180mm x 1.6mm x 25.4/22mm	8600	1	10mm	ABDCR180
230mm x 2.4mm x 25.4/22mm	6600	1	10mm	ABDCR230

Abracs

Surface Conditioning



Product Group 94

Extensive range of expert quality Cobalt Holesaws for use on a wide range of applications. Abracs Cobalt Holesaws are designed for use by professional trades people and manufactured from premium quality materials.

COBALT HOLESAW



Specification	Box Qty	Outer Qty	Prod. Code
14mm	1	200	ABHSC014
16mm	1	200	ABHSC016
17mm	1	200	ABHSC017
19mm	1	200	ABHSC019
20mm	1	200	ABHSC020
21mm	1	200	ABHSC021
22mm	1	200	ABHSC022
25mm	1	200	ABHSC025
27mm	1	200	ABHSC027
30mm	1	200	ABHSC030
32mm	1	200	ABHSC032
35mm	1	200	ABHSC035
38mm	1	100	ABHSC038
40mm	1	100	ABHSC040
41mm	1	100	ABHSC041
44mm	1	100	ABHSC044
48mm	1	50	ABHSC048

Specification	Box Qty	Outer Qty	Prod. Code
51mm	1	50	ABHSC051
54mm	1	50	ABHSC054
57mm	1	50	ABHSC057
60mm	1	50	ABHSC060
64mm	1	50	ABHSC064
65mm	1	50	ABHSC065
70mm	1	50	ABHSC070
73mm	1	50	ABHSC073
76mm	1	50	ABHSC076
79mm	1	50	ABHSC079
83mm	1	50	ABHSC083
102mm	1	25	ABHSC102
108mm	1	25	ABHSC108
114mm	1	10	ABHSC114
127mm	1	10	ABHSC127
152mm	1	10	ABHSC152

ARBOR & PILOT DRILL BITS



Specification	Box Qty	Prod. Code
A1 Arbor To Fit Holesaw 14mm-30mm	1	ABHSA1
A2 Arbor To Fit Holesaw 32mm-152mm	1	ABHSA2
A1 Sds Arbor To Fit Holesaw Sizes 14mm-30mm	1	ABHSSDSA1
A2 Sds Arbor To Fit Holesaw Sizes 32mm-152mm	1	ABHSSDSA2
Hole Saw Pilot Drill Bit	10	ABHSPILLOT

HOLESAW KITS



Specification	Box Qty	Prod. Code
11pc ELECTRICIANS COBALT HOLESAW KIT	1	ABHCKIT11
17pc PLUMBERS COBALT HOLESAW KIT	1	ABHCKIT17



Abracs

Screwdriver Bits



Product Group 94

Abracs Screwdriver Bits are manufactured with S2 Premium Steel Quality Construction materials for long life and are suitable for all heavy duty screwdriving applications. Measuring 25mm in length they are available in a range of Head types - PZ1, PZ2, PZ2 & PH2.



Specification	Box Qty	Prod. Code
25MM PZ2 SCREWDRIVER BIT (100PC TUB)	1	PZ2100



Specification	Box Qty	Prod. Code
PK (5 x 25PCS) PH2 25mm Screwdriver Bit	1	PH205
PK (5 x 25PCS) PZ1 25mm Screwdriver Bits	1	PZ105
PK (5 x 25PCS) PZ2 25mm Screwdriver Bits	1	PZ205
PK (5 x 25PCS) PZ3 25mm Screwdriver Bits	1	PZ305

Abracs Reciprocating Saw Blade range is packed with product features such as ultra flexible for flush cutting, heavy duty for strength & durability and progressive cutting for a smooth start to cutting hard materials. There is selected high carbon steel, bi-metal and HSS material blade construction within the product ranges to ensure maximum performance when used on the intended application.

RECIP SAW BLADE



Specification	Box Qty	Prod. Code
150x19x0.9mm - METAL (5)	1	RBS123XF A
150x19x0.9mm - METAL (5)	1	RBS922BF
150x19x0.9mm - METAL (5)	1	RBS922EF
150x19x0.9mm - METAL (5)	1	RBS922AF
225x19x0.9mm - METAL (5)	1	RBS1122BF
225x19x0.9mm - METAL (5)	1	RBS1122EF
225x19x0.9mm - METAL (5)	1	RBS1122AF
150x19x0.9mm WOOD/METAL (5)	1	RBS922HF B
225x19x1.25mm WOOD/METAL (5)	1	RBS1111DF
225x19x0.9mm WOOD/METAL (5)	1	RBS1122VF
300x19x1.25mm WOOD/METAL (5)	1	RBS1411DF
150x19x1.2mm - WOOD (5)	1	RBS617K C
150x19x1.2mm - WOOD (5)	1	RBS644D
240x19x1.5mm - WOOD (5)	1	RBS1531L
300x19x1.2mm - WOOD (5)	1	RBS1617K
150x22x1.6mm DEMOLITION (3)	1	RBSDEM150 D
225x22x1.6mm DEMOLITION (3)	1	RBSDEM225
8 pc MIXED PACK-2x RBS922HF. 2x RBS922EF. 2x RBS644D. 2x RBS1531L	1	RBSMIX8 E

Abracs

Jigsaw Blades



Product Group 94

Abracs Jigsaw Blades come in an extensive range of sizes, tooth shapes and configurations and are manufactured using a variety of materials to make each individual blade the highest possible performance for cutting the intended material application. There is specific blades for use on wood, metal, wood & metal and aluminium cutting applications.



Specification	Box Qty	Outer Qty	Prod. Code
PK 5 CLEAN WOOD 1.4MM TEETH	1	50	ABT101AO
PK 5 HARDWOOD 1.4MM TEETH	1	50	ABT101AOF
PK 5 CLEAN WOOD 2.7MM TEETH	1	50	ABT101B
PK 5 CLEAN WOOD 2.5MM TEETH	1	50	ABT101BR
PK 5 CLEAN WOOD 4MM TEETH	1	50	ABT101D
PK 5 STD WOOD 3MM TEETH	1	50	ABT111C
PK 5 STD METAL 1.5MM TEETH	1	50	ABT118A
PK 5 STD METAL 2.3MM TEETH	1	50	ABT118B
PK 5 STD METAL 0.7MM TEETH	1	50	ABT118G
PK 5 STD WOOD 2MM TEETH	1	50	ABT119B
PK 5 STD WOOD 2MM TEETH	1	50	ABT119BO
PK 5 ALUM/METAL 3MM TEETH	1	50	ABT127D
PK 5 FAST WOOD 4MM TEETH	1	50	ABT144D
PK 5 FAST WOOD 4MM TEETH	1	50	ABT144DP
PK 5 FAST WOOD 4MM TEETH	1	50	ABT244D
PK 5 STD METAL 1.2MM TEETH	1	50	ABT318A
PK 5 STD METAL 2MM TEETH	1	50	ABT318B
PK 5 WOOD/MET 2-4.5MM TEETH	1	50	ABT345XF



Specification		Box Qty	Prod. Code
10PC JIGSAW BLADE MIXED PACK	2x ABT111C. 2x ABT19BO. 2x ABT101B. 2x ABT118A. 2x ABT127D	1	ABTMIX10



Coated Abrasives



Product Group 94

The Abracs range of Coated Abrasives includes Sanding Belts, Emery Rolls, Waterproof Paper, Emery Sheets, Floor Sander Sheets, P.S.A. Discs, Hook & Loop products, Mesh Sanding Sheets, Pole Sanding Sheets and many more. All products are manufactured using premium quality materials to ensure top quality performance and excellent results every time.

EMERY ROLLS



Specification	Box Qty	Outer Qty	Prod. Code
25mm x 50M x 40grit	1	10	ABER2550040
25mm x 50M x 60grit	1	10	ABER2550060
25mm x 50M x 80grit	1	10	ABER2550080
25mm x 50M x 100grit	1	10	ABER2550100
25mm x 50M x 120grit	1	10	ABER2550120
25mm x 50M x 150grit	1	10	ABER2550150
25mm x 50M x 180grit	1	10	ABER2550180
25mm x 50M x 280grit	1	10	ABER2550280
50mm x 50M x 40grit	1	10	ABER5050040
50mm x 50M x 60grit	1	10	ABER5050060
50mm x 50M x 80grit	1	10	ABER5050080
50mm x 50M x 100grit	1	10	ABER5050100
50mm x 50M x 120grit	1	10	ABER5050120
50mm x 50M x 150g	1	10	ABER5050150
50mm x 50M x 180g	1	10	ABER5050180
50mm x 50M x 280g	1	10	ABER5050280

EMERY SHEETS



40 grit	25	250	ABES040
60 grit	25	250	ABES060
80 grit	25	250	ABES080
100 grit	25	250	ABES100
120 grit	25	250	ABES120
150 grit	25	250	ABES150
280 grit	25	250	ABES280

WATERPROOF PAPER SHEETS



120 grit	25	500	ABWD0120
180 grit	25	500	ABWD0180
220 grit	25	500	ABWD0220
240 grit	25	500	ABWD0240
280 grit	25	500	ABWD0280
320 grit	25	500	ABWD0320
400 grit	25	500	ABWD0400
600 grit	25	500	ABWD0600
800 grit	25	500	ABWD0800
1000 grit	25	500	ABWD1000
1200 grit	25	500	ABWD1200
1500 grit	25	500	ABWD1500
2000 grit	25	500	ABWD2000

GENERAL PURPOSE SANDPAPER SHEETS



230mm x 280mm x 40g	25	250	ABSP040
230mm x 280mm x 60g	25	250	ABSP060
230mm x 280mm x 80g	25	250	ABSP080
230mm x 280mm x 120g	25	250	ABSP120
230mm x 280mm x 180g	25	250	ABSP180
230mm x 280mm x 240g	25	250	ABSP240

Abracs

Coated Abrasives



Product Group 94

GENERAL PURPOSE SANDPAPER ROLLS



Specification	Box Qty	Outer Qty	Prod. Code
115mm x 5M x 40G	1	20	ABS11505040
115mm x 5M x 60G	1	20	ABS11505060
115mm x 5M x 80G	1	20	ABS11505080
115mm x 5M x 100G	1	20	ABS11505100
115mm x 5M x 120G	1	20	ABS11505120
115mm x 5M x 150G	1	20	ABS11505150
115mm x 5M x 180G	1	20	ABS11505180
115mm x 5M x 240G	1	20	ABS11505240
115mm x 10M x 40G	1	20	ABS11510040
115mm x 10M x 60G	1	20	ABS11510060
115mm x 10M x 80G	1	20	ABS11510080
115mm x 10M x 100G	1	20	ABS11510100
115mm x 10M x 120G	1	20	ABS11510120
115mm x 10M x 150G	1	20	ABS11510150
115mm x 10M x 180G	1	20	ABS11510180
115mm x 10M x 240G	1	20	ABS11510240
115mm x 50M x 40G	1	4	ABS11550040
115mm x 50M x 60G	1	4	ABS11550060
115mm x 50M x 80G	1	4	ABS11550080
115mm x 50M x 100G	1	4	ABS11550100
115mm x 50M x 120G	1	4	ABS11550120
115mm x 50M x 150G	1	4	ABS11550150
115mm x 50M x 180G	1	4	ABS11550180
115mm x 50M x 240G	1	4	ABS11550240

DECORATORS SANDPAPER ROLLS



115MM X 5M X 40G	1	20	ABSG11505040
115MM X 5M X 60G	1	20	ABSG11505060
115MM X 5M X 80G	1	20	ABSG11505080
115MM X 5M X 120G	1	20	ABSG11505120

SANDING BELTS - ALUMINIUM OXIDE



100mm x 610mm x 40grit	10	100	ABSB100610040
100mm x 610mm x 60grit	10	100	ABSB100610060
100mm x 610mm x 80grit	10	100	ABSB100610080
100mm x 610mm x 100grit	10	100	ABSB100610100
100mm x 610mm x 120grit	10	100	ABSB100610120
100mm x 610mm x 150grit	10	100	ABSB100610150



Coated Abrasives



Product Group 94

HOOK & LOOP SANDING DISCS



Specification	Box Qty	Outer Qty	Prod. Code
125mm x 40g - 0 HOLES	25	500	ABHL0125040
125mm x 60g - 0 HOLES	25	500	ABHL0125060
125mm x 80g - 0 HOLES	25	500	ABHL0125080
125mm x 100g - 0 HOLES	25	500	ABHL0125100
125mm x 120g - 0 HOLES	25	500	ABHL0125120
125mm x 180g - 0 HOLES	25	500	ABHL0125180
125mm 220/240g 0 HOLES	25	500	ABHL0125240
125mm x 400g - 0 HOLES	25	500	ABHL0125400
150mm x 40g - 0 HOLES	25	250	ABHL0150040
150mm x 60g - 0 HOLES	25	250	ABHL0150060
150mm x 80g - 0 HOLES	25	250	ABHL0150080
150mm x 100g - 0 HOLES	25	250	ABHL0150100
150mm x 120g - 0 HOLES	25	250	ABHL0150120
150mm x 180g - 0 HOLES	25	250	ABHL0150180
150mm 220/240g 0 HOLES	25	250	ABHL0150240
150mm x 320g - 0 HOLES	25	250	ABHL0150320
150mm x 400g - 0 HOLES	25	250	ABHL0150400
125mm x 40g - 8 HOLES	25	500	ABHL8125040
125mm x 60g - 8 HOLES	25	500	ABHL8125060
125mm x 80g - 8 HOLES	25	500	ABHL8125080
125mm x 100g - 8 HOLES	25	500	ABHL8125100
125mm x 120g - 8 HOLES	25	500	ABHL8125120
125mm x 180g - 8 HOLES	25	500	ABHL8125180
125mm 220/240g 8 HOLES	25	500	ABHL8125240
125mm x 320g - 8 HOLES	25	500	ABHL8125320
125mm x 400g - 8 HOLES	25	500	ABHL8125400
150mm x 40g - 6 HOLES	25	250	ABHL8150040
150mm x 60g - 6 HOLES	25	250	ABHL8150060
150mm x 80g - 6 HOLES	25	250	ABHL8150080
150mm x 100g - 6 HOLES	25	250	ABHL8150100
150mm x 120g - 6 HOLES	25	250	ABHL8150120
150mm x 180g - 6 HOLES	25	250	ABHL8150180
150mm 220/240g 6 HOLES	25	250	ABHL8150240
150mm x 320g - 6 HOLES	25	250	ABHL8150320
150mm x 400g - 6 HOLES	25	250	ABHL8150400

PSA SANDING DISCS



150mm x 40g	100	600	ABPSA150040
150mm x 60g	100	600	ABPSA150060
150mm x 80g	100	600	ABPSA150080
150mm x 120g	100	600	ABPSA150120
150mm x 180g	100	600	ABPSA150180
150mm x 220/240g	100	600	ABPSA150240
150mm x 320g	100	600	ABPSA150320

PSA BACKING PAD



150mm x 5/16 UNF	1	100	ABPSABP150
------------------	---	-----	------------

Abracs

Coated Abrasives



Product Group 94

MESH SANDING STRIPS



Specification	Box Qty	Outer Qty	Prod. Code
230x38mm	10	1000	ABMS0180

WIRE WOOL



Specification	Box Qty	Outer Qty	Prod. Code
FINE (GRADE 0)	1	30	ABWW0
MEDIUM (GRADE 2)	1	30	ABWW2
COARSE (GRADE 3)	1	30	ABWW3

SPIRABAND KIT



Specification	Box Qty	Prod. Code
25pc ABRACS SPIRABAND KIT - ZIRCONIUM	Spirabands - 4 x 13mm, 19mm, 25mm, 38mm, 50mm. Abrors - 1 x 13mm, 19mm, 25mm, 38mm, 50mm	1 ABSRKITZ

Screwmagnet



Product Group 94

The Screwmagnet features a super strong magnet with a bearing strength of 25 lbor holding up to 11.3kg's. The Neodymium magnet is the strongest type available worldwide today and can hold anything from a screw to tools such as screwdrivers & even hammers.



Specification	Box Qty	Outer Qty	Prod. Code
ABRACS SCREW MAGNET	1	48	SCRMAG



Wire Brushes



Product Group 94

Abracs comprehensive range of wire brushes are tested to extremes to ensure maximum performance when used in industrial environments. Abracs stock an unrivalled range of wire brushes for all machine types and applications, both general purpose and specialist.

WIRE BRUSHES



Specification	Max Rpm	Box Qty	Seg Height	Prod.Code
70mm x M10 x1.5 T/Knot Wirebrush	12500	1	60	ABWB07010T1.5
70mm x M14 T/Knot Wirebrush S/S	12500	1	60	ABWB07014ST
70mm x M14 T/Knot Wirebrush	12500	1	60	ABWB07014T
95mm x M14 T/Knot Wirebrush	8500	1	20	ABWB09514T
120mm x M14 T/Knot Wirebrush	6500	1	10	ABWB12014T

CRIMP WIREBRUSH



ABRACS 75mmx M14	12500	1	60	ABWB07514C
ABRACS 75mmx M14	12500	1	60	ABWB07514SC
ABRACS 100mm x M14	8500	1	30	ABWB10014C
ABRACS 120mm x M14	6500	1	20	ABWB12014C

CRIMP WIRE WHEEL



150mm x 20mm CRIMP	6000	1	30	ABWBWF15020C
200mm x 25mm CRIMP	4500	1	20	ABWBWF20025C

BEVEL BRUSH



100mm x M14 T/KNOT	12500	1	60	ABWBB100M14T
115mm x M14 CRIMP	12500	1	60	ABWBB115M14C
115mm x M14 T/KNOT	12500	1	60	ABWBB115M14T

SPINDLE MOUNTED BRUSH



50mm CIRCULAR WIRE BRUSH	4500	1	120	ABWBCIR50
75mm CIRCULAR WIRE BRUSH	4500	1	120	ABWBCIR75
75mm CIRCULAR BRUSH S/S	4500	1	120	ABWBCIR75S
75mm CUP WIRE BRUSH	4500	1	100	ABWBCUP75
19mm END BRUSH	4500	1	200	ABWBEND

Specification	Box Qty	Prod.Code
40PC MIXED DISPLAY 8 x 50mm Crimped Circular Brush. 8 x 50mm Crimped Cup Brush. 8x 75mm Crimped Cup Brush. 8x75mm Crimped Circular Brush. 8 x 19mm Crimped End Brush	1	ABWBSMDISP

WOODEN HANDLED BRUSH



Specification	Box Qty	Outer Qty	Prod.Code
4 Row Wooden Handled Brush	12	120	ABWHB4
Scratch Brush (4 Row) With Metal Scraper	12	120	ABWHBSCR
Plastic Handle Scratch Brush. Brass Dip	24	24	ABWBSCRATCH
Scratch Brush (Stainless Steel)	24	24	ABWBSCRATCHSS

Action Can

General Lubricants



Product Codes Begin **Q99** Product Group **92**



Article No.	Description	Box Qty.	
AC90 425ML	AC90 Multi-Purpose Lubricant 425ml	CTN 15	A
AC90 5LTR	AC90 Multi-Purpose Lubricant 5l Can	CTN 4	
HX571461	AC90 TwinSpray 500ml	CTN 15	B
HX571478	AC90 Fluid 5ltr Pack with Trigger Spray	CTN 1	



Key Features • Does not contain Silicone or CFC • Multi-purpose industrial spray lubricant/cleaner • Strong water and moisture displacing action
• Penetrates rust and corrosion • Cleans and Protects all metals against rust • Suitable for electronic ignition systems

Application • Anti-seize, Assembly, Dismantle • Cleaners / Degreasers • Corrosion Protection • Electrical Products
• General Lubricant • Release Fluids • Welding Products • Plumbing Products



SL90 500ML	SL90 Lubricating Oil + PTFE 500ml	CTN 15	C
------------	-----------------------------------	--------	----------

Key Features • Fully synthetic • Strong anti fling properties • Wide operating temperature range from -35°C to +200°C • Multi viscosity capability
• Good metal to metal parts lubrication • Water, steam, acid and alkalis resistant • Corrosion inhibitor built into formulation • Clean and clear
• Silicone and CFC free

Application • Chain Lubricant • General Lubricant • PTFE Lubricant • Electrical Products



CG90 500ML	CG90 Clear Grease 500ml	CTN 15	D
------------	-------------------------	--------	----------

Key Features • Food Grade certified to H1 standard by InS 1795391 • Clean and clear • Non toxic no odour
• Reduced stick slip behaviour • Corrosion inhibitor built into formulation • Water, steam, acid and alkalis resistant
• Wide temperature range from -40°C to +200°C (applies to base product before aerosol packing)

Application • Food Grade Products • Bearing Lubricant • Chain Lubricant • Corrosion Protection • General Lubricant
• PTFE Lubricant • Plumbing Products • Electrical Products



CS90 500ML	CS90 Copper Anti-Seize Grease 500ml Aerosol	CTN 15	E
CS90 500GR	CS90 Copper Anti-Seize Grease 500g Tub Compound	CTN 12	

Key Features • High quality grease • Free from lead, zinc, nickel, and silicone • Contains pure micro fine copper flake and micro fine graphite flakes
• Very high temperature resisting rate 1200°C • Increased lubrication with added graphite
• Waterproof, anti-corrosion, anti-rust, anti-acid and heat resistant

Application • Anti-seize, Assembly and Dismantle



RP90 500ML	RP90 Rapid Penetrating Oil 500ml	CTN 15	F
------------	----------------------------------	--------	----------

Key Features • Excellent penetrating power • Fast acting releasing capability • Protects against rust and corrosion • Reduces friction and wear

Application • Anti-seize, Assembly and Dismantle • General Lubricant • Release Fluids • Plumbing Products • Electrical Products



WG90 500ML	WG90 White Grease 500ml	CTN 15	G
------------	-------------------------	--------	----------

Key Features • General purpose lasting lubricant • Reduces wear • Heat and water resistant • Corrosion preventive

Application • Bearing Lubricant • Chain Lubricant • Corrosion Protection • General Lubricant • Electrical Products



Food Grade Lubricants



Product Codes Begin **Q99** Product Group **92**



Article No.	Description	Box Qty.
AC90 FGR 500ML	AC90 H1 Food Grade Multi Purpose Lubricant 500ml	CTN 15

- Key Features**
- H1 Food Grade certified by NSF #14359 and InS #1795389 • Cleans and Protects all metals against rust
 - Essential for safe operations and manufacturing for pharmaceutical, food and beverage industries • Does not contain Silicone or CFC
 - Tasteless and odourless • Multi-purpose industrial spray lubricant/cleaner • Penetrates rust and corrosion

- Application**
- Food Grade Products • Anti-seize, Assembly & Dismantle • Cleaners / Degreasers • Corrosion Protection
 - General Lubricant • Release Fluids • Welding Products • Plumbing Products • Electrical Products



AG90S 200ML	AG90 Food Grade Anti Galling Lubricant 200ml Aerosol	CTN 6
AG90M 125ML	AG90 Food Grade Anti Galling Lubricant 125ml can with spout	CTN 12
AG90S 125ML	AG90 Food Grade Anti Galling Lubricant 125ml can with spout	CTN 6

- Key Features**
- H1 food grade certified by InS #1796317 • Prevents fastener threads seizing and galling on Stainless Steel fasteners
 - Lubricates a wide range of components and machinery moving parts • Recommended for all assembly work • Reduces wear and friction
 - Ease of assembly and disassembly of fasteners and mechanisms • Protects against rust and corrosion in even the harshest industrial environments

- Application**
- Food Grade Products • Anti-seize, Assembly & Dismantle • PTFE Lubricant



SC90 500ML	SC90 Food Grade Stainless Steel Cleaner 500ml	CTN 15
------------	---	--------

- Key Features**
- Cleaning all types of Stainless Steel surfaces and equipment • Leaves a unique protective soil resistant film on treated surfaces
 - Removes finger prints, water marks, all types of food residue • Does not contain solvent, abrasives, acids, bleach or salts • Retains a lasting shine
 - A1 food grade approval certified by InS #1795951 • For use on surfaces in food processing areas

- Application**
- Food Grade Products • Cleaners / Degreasers



SP90 FGR 500ML	SP90 Food Grade Dry Film Silicone Lubricant 500ml	CTN 15
----------------	---	--------

- Key Features**
- H1 Food grade • Certified by NSF #143541 and InS #1795388 • Superior non toxic maximum silicone lubricant
 - Clear, clean, and dry lubricating film • Low odour and non staining lubricant spray • Reduces friction and static • Stable over a wide temperature range
 - Prevents sticking of rubber or plastic parts • Protects against corrosion and oxidation • Ideal for use on rubber, plastics, metal, vinyl, and glass

- Application**
- Food Grade Products • Anti-seize, Assembly & Dismantle • Silicone Lubricant • Release Fluids • Plumbing Products • Electrical Products



CD90 FGR 500ML	CD90 H1 Food Grade Chain & Drive Spray 500ml	CTN 15
----------------	--	--------

- Key Features**
- H1 Food grade certified by NSF #143540 • H1 & 3H Incidental and direct food contact certification InS #1795390
 - Water displacing properties ideal for wet and damp conditions • Silicone or CFC free
 - Anti fling properties • Strong anti rust capability • Highly water resistant and repellent • No added solvent
 - Temperature range -12°C to 200°C (applies to base product before aerosol packing) • Viscosity at 20°C

- Application**
- Food Grade Products • Bearing Lubricant • Chain Lubricant • Electrical Products

Action Can

Chain Lubricants



Product Codes Begin **Q99** Product Group **92**



Article No.	Description	Box Qty.
CD90 500ML	CD90 Chain & Drive Spray 500ml	CTN 15

Key Features

- Multi viscosity capability • Ideal for wet and damp conditions • Silicone or CFC free • Anti fling properties • Strong anti rust capability
- Highly water resistant and repellent • Water displacing properties • No added solvent

Application

- Bearing Lubricant • Chain Lubricant • Electrical Products

Belt Lubricants



BD90 500ML	BD90 Drive Belt Dressing Spray 500ml	CTN 15
------------	--------------------------------------	--------

Key Features

- Restores and adds grip to drive belts • Reduces belt slippage and glazing • Prolongs belt life • Increases power transfer
- Prevents belts cracking • Ideal for wet belts and belts in outdoor environments • Displaces moisture

Application

- Bearing Lubricant • Agricultural equipment • Conveyor belts

Machine Oil Lubricants



HX573571	MO90 Machine Oil Lubricant 500ml	CTN 15
----------	----------------------------------	--------

Key Features

- Highly refined oil • Non-staining • Effective temperature range -15°C to +150°C

Application

- Chains, conveyors and mechanical parts

Dry Lubricants – Non Silicone



DM90	DM90 Dry Moly Spray Lubricant 500ml	CTN 15
------	-------------------------------------	--------

Key Features

- Long lasting non greasy dry film lubricant • Touch dry in 15 minutes / can be polished after 12 hours
- Performs well under extremely heavy loads, high pressure and high temperature • Low coefficient of friction
- Reduces wear and abrasion • Effective corrosion resistant / low friction coating • Prevents galling, seizing, and sticking

Application

- Extreme Pressure Lubricant



PTFE 500ML	PTFE Dry Film Lubricant 500ml	CTN 15
------------	-------------------------------	--------

Key Features

- Food Grade certified to H1 standard by InS 1795391 • Clean and clear • Non toxic no odour • Reduced stick slip behaviour
- Corrosion inhibitor built into formulation • Water, steam, acid and alkalis resistant
- Wide temperature range from -40°C to +200°C (applies to base product before aerosol packing)

Application

- Food Grade Products • Bearing Lubricant • Chain Lubricant • Corrosion Protection • General Lubricant
- PTFE Lubricant • Plumbing Products • Electrical Products

Dry Lubricants Silicone



SP90 500ML	SP90 Dry Film Silicone Lubricant 500ml	CTN 15
------------	--	--------

Key Features

- Superior non toxic maximum silicone lubricant • Superior non toxic maximum silicone lubricant • Clear, clean, and dry lubricating film
- Low odour and non staining lubricant spray • Reduces friction and static • Stable over a wide temperature range
- Prevents sticking of rubber or plastic parts • Protects against corrosion and oxidation • Ideal for use on rubber, plastics, metal, vinyl, and glass

Application

- Anti-seize, Assembly & Dismantle • Silicone Lubricant • Release Fluids • Plumbing Products • Electrical Products



Paints



Product Codes Begin **Q99** Product Group **92**



Article No.	Description	Box Qty.
LM90 BLACK	LM90 Line Marker Black 750ml - RAL 9004	CTN 12
LM90 BLUE	LM90 Line Marker Blue 750ml - RAL 5015	CTN 12
LM90 GREEN	LM90 Line Marker Green 750ml - RAL 6018	CTN 12
LM90 ORANGE	LM90 Line Marker Orange 750ml - RAL 2003	CTN 12
LM90 RED	LM90 Line Marker Red 750ml - RAL 3018	CTN 12
LM90 WHITE	LM90 Line Marker White 750ml - RAL 9003	CTN 12
LM90 YELLOW	LM90 Line Marker Yellow 750ml - RAL 1018	CTN 12

- Key Features**
- Fast drying application
 - Lead free product
 - Highly durable and hard wearing
 - Range of bright colours white, yellow, red, blue, green, orange, and black
 - For use on internal and external areas

- Application**
- Safety products

Anti-Corrosion



RX90 500ML	RX90 Red Oxide Anti Rust Primer Oxide Spray 500ml	CTN 15
------------	---	--------

- Key Features**
- Guards against rust
 - Effective on bare metal or lightly rusted metal surfaces
 - Use as an undercoat with most popular paints
 - Protective basecoat
 - Low topcoat absorption
 - Fast drying formula

- Application**
- Anti-rust Paint



MZ90 500ML	MZ90 Matt Zinc Galvanising Spray 500ml	CTN 15
------------	--	--------

- Key Features**
- Repair coating for newly galvanized metal
 - Fast drying
 - Long term protection against rust and corrosion
 - Two buttons for varied spray patterns and easy application in exterior conditions
 - High performance finish
 - Zinc purity 98%



ZG90 500ML	ZG90 Cold Zinc Galvanising Spray 500ml	CTN 15
ZG90BL	ZG90 Satin Finish Paint Blue 500ml - RAL 5012	CTN 15
ZG90GRE	ZG90 Satin Finish Paint Green 500ml - RAL 6010	CTN 15
ZG90RED	ZG90 Satin Finish Paint Red 500ml -RAL 3000	CTN 15
ZG90YLW	ZG90 Satin Finish Paint Yellow 500ml - RAL 1004	CTN 15
ZG90WHT	ZG90 Satin Finish Paint White 500ml - RAL 9010	CTN 15
ZG90BLK	ZG90 Satin Finish Paint Black 500ml - RAL 9005	CTN 15
ZG90B 500ML	ZG90 Cold Zinc Galvanising Brush On 500ml	CTN 6
ZG90BLKBR 500ML	ZG90 Cold Zinc Galvanising Brush On - Black 500ml	CTN 6

- Key Features**
- Repair coating for newly galvanized metal
 - Extremely fast drying
 - Long term protection against rust and corrosion
 - Two buttons for varied spray patterns and application in exterior windy conditions
 - High performance finish
 - Zinc purity 98%
 - Suitable as a base for most common finishes
 - Also available in red, blue, green, white and black

- Application**
- Anti-rust Paint

Action Can

Cleaners



Product Codes Begin **Q99** Product Group **92**



Article No.	Description	Box Qty.
ANTISTATIC	Anti-Static Foam Cleaner 500ml	CTN 15

- Key Features**
- Cleaner for removing oil, grease, general soiling, dust and other contaminants
 - Foaming action for penetration of the contamination
 - A multi-surface cleaner for plastics, metals, ceramic, glass windows, Stainless Steel and mirrors
 - Strong anti-static properties

- Application**
- Cleaners / Degreasers



ESC 500ML	EC90 Electrical Contact Cleaner Spray 500ml	CTN 15
-----------	---	--------

- Key Features**
- Provides a good quality cleaning of electrical parts and components
 - Residue free
 - Removes oil, greases, dirt and grime
 - Delays corrosion and oxidation
 - Fast drying
 - Gentle manner on delicate components
 - Prolongs life of switch

- Application**
- Cleaners / Degreasers
 - Electrical Products



GC 750ML	Blue Crystal Glass Cleaner A1 Food Grade 750ml	CTN 12
----------	--	--------

- Key Features**
- Holds A1 Food Grade approval for use in all food handling, manufacture and storage locations
 - Multi-purpose glass cleaner and polish
 - Very effective, fast and easy to use
 - Rapid cleaning
 - Smear free finish
 - No streaking
 - Anti static additive to prevent the build up of dust on surfaces
 - A1 Food grade certified InS #1795625

- Application**
- Cleaners / Degreasers
 - Food Grade



BC90 500ML	BC90 Brake & Clutch Cleaner 500ml	CTN 15
------------	-----------------------------------	--------

- Key Features**
- Strong action that cleans brakes and clutch parts
 - Removes dirt, grime, dust, fluids, oils and other contaminants
 - Can be used as a solvent and degreaser of metal parts
 - Free from CFCs
 - Evaporates leaving no residue
 - Ease brake squeal and clutch chatter
 - Use without dismantling brakes and clutches

- Application**
- Cleaners / Degreasers



HAND 5LTR	Lemon Hand Cleaner 5l	CTN 4
-----------	-----------------------	-------

- Key Features**
- Industrial strength hand cleaner
 - Contains poly granules
 - Tough on embedded oil, grease and dirt
 - Fresh clean lemon fragrance
 - Non-solvent formula
 - Added moisturiser

- Application**
- Cleaners / Degreasers



IPA 500ML	Isopropyl Alcohol Solvent Cleaner 500ml	CTN 15
-----------	---	--------

- Key Features**
- Multi-purpose cleaning solvent
 - Cleans electrical contacts and components
 - Delicate formulation can be used on rubber and plastic electrical parts
 - Rapid evaporating
 - Leaves no residue
 - Conforms to BS 1595/ASTM D770/DIN 53245

- Application**
- Cleaners / Degreasers
 - Electrical Products



Cleaners

Product Codes Begin **Q99** Product Group **92**



Article No.	Description	Box Qty.
WIPE 6X80	Large Wipes Tub 80 Sheets	CTN 6

- Key Features**
- Large industrial grade deep cleaning wipes for quick job site cleaning
 - Multi-purpose for cleaning hands, tools, equipment and hard surfaces
 - Hard surface wipes for all types of metal, gloss painted wood, plastic and glass
 - Quick clean up of light contamination of oil, grease, wet paint, wet tar, silicone, gap fill adhesive, PU foam and all general soiling
 - Infused with a disinfectant non toxic cleaning fluid which is kind on hands
 - Convenient and portable as water is not required and good hygiene is essential
 - Easy to dispense container and snap lid
 - Contains 80 Large size wipes

- Application**
- Cleaners / Degreasers



TF90 500ML	TF90 Fast Drying Cleaning Solvent and Degreaser 500ml	CTN 15
------------	---	--------

- Key Features**
- Effective and quick cleaner and degreaser
 - Fast removal of oil, grease, tar, wax, carbon and containments
 - Evaporating action leaves a clean, clear, and dry surface
 - Replacement for 111-Trichloroethane based products

- Application**
- Anti-seize, Assembly & Dismantle
 - Cleaners / Degreasers
 - Welding Products
 - Electrical Products

Adhesives



SA90 500ML	SA90 Heavy Duty Industrial Adhesive 500ml	CTN 15
------------	---	--------

- Key Features**
- Restores and adds grip to drive belts
 - Reduces belt slippage and glazing
 - Prolongs belt life
 - Increases power transfer
 - Prevents belts cracking
 - Ideal for wet belts and belts in outdoor environments
 - Displaces moisture

- Application**
- Bearing Lubricant

Cutting & Tapping



CT90 480GR	CT90 Cutting & Tapping Compound 480g	CTN 12
CT90 500ML	CT90 Cutting Fluid Bottle with Spout 500ml	CTN 12
CT90 500ML	CT90 Cutting & Tapping Aerosol 500ml	CTN 15
CT90 5LTR	CT90 Cutting & Tapping Bulk Fluid 5l	CTN 1

- Key Features**
- Drilling, sawing, and thread cutting simplified
 - Safe on steels, designed for Stainless Steel and ceramics
 - Extends tool life
 - High rates of metal removal
 - High anti weld features
 - Extreme pressure rated lubricant
 - Silicone and CFCs Free
 - Reduces heat and improves surface finish
 - Poly bottle packs for flood lubrication

- Application**
- Cutting Fluid
 - Electrical Products

Action Can

Compressor Oil



Product Codes Begin **Q99** Product Group **92**

Article No.	Description	Box Qty.
AT90 500ML	AT90 Air Tool Lubricant Bottle with Spout 500ml	CTN 12
AT90 5LTR	AT90 Air Tool Lubricant 5l	CTN 1

Key Features • For all air operated tools • Excellent air release quality • Low foaming ability • Can be mixed with all mineral based lubricants without draining system
• Prolongs tool life • Maximises tool performance • ISO GRADE VG22 • Removes moisture • Inhibits rust and corrosion

Application • Compressor Oil

Corrosion Protection



ST 500ML	Supertrol Anti-Rust Fluid 500ml	CTN 15
----------	---------------------------------	--------

Key Features • Excellent penetrating capability • Prevents corrosion • Dries to a soft film • Clear film

Application • Compressor Oil

Leak Detector



LD90 400ML	LD90 Gas Leak Detector 400ml	CTN 15
LD90 250ML	LD90 Gas Leak Detector Gel 250ml	CTN 15

Key Features • Detects minute leaks and leaks under pressure • Non flammable, non toxic, kind to skin • Meets British standards BS EN 14291: 2004
• Compressed air propellant • Conforms with VOSA leak detector British standard BS EN 14921:2004 requirement for use in MOT testing station

Application • Plumbing Products

Welding



AS90 400GR	AS90 Welders Multi-Purpose Anti-Spatter Spray 400g	CTN 15
------------	--	--------

Key Features • Pre-weld spray • Welding Wire lubricant • Post weld Corrosion protector
• Anti-spatter • Prevents the formulation of rust • Silicone free • Easy to wipe or rub away

Application • Welding Products



Metolux Wood Filler Products



Timbafil Two-Part Wood Filler



Product Codes Begin **9METOLUX** Product Group **93**

Article No.	Description	Box Qty.	Article No.	Description	Box Qty.
31195	275ml Pine	2	31196	770ml Pine	2
31201	275ml Redwood/Light	2	31202	770ml Redwood/Light	2
31192	275ml Teak/ D Oak	2	31193	770ml Teak/ D Oak	2
31198	275ml Light Oak	2	31199	770ml Light Oak	2
31189	275ml White	2	31190	770ml White	2
31204	275ml Mahogany/Dark	2	31205	770ml Mahogany/Dark	2

- High performance polyester wood filler • Ready to use tin with hardener and activator • Available in a large range of colours • Easily blended
- Paintable and stainable variants • Large scale repairs up to 5-6mm depth • Frames, sills, doors, furniture, skirting and fencing amongst the possible applications
- Easy to sand and paint without primers, accepts screws, nails and staples

Timbermate One-Part Wood Filler



Product Codes Begin **9METOLUX** Product Group **93**

30001	250ml White	6	30004	250ml Teak / Dark Oak	6
30002	250ml Pine	6	30005	250ml Mahogany	6
30003	250ml Light Oak	6	30006	250ml Stainable Light	6

- Ready to use air drying wood stopper • For pinholes and fine grain • Stainable or pre-matched • Cost effective and simple to use
- Ideal for small cracks and imperfections • Use as a filler for example in screw holes

Hardeners



Product Codes Begin **9METOLUX** Product Group **93**

32002	40g Speedset Hardener	1 x 25
-------	-----------------------	--------



Bond It Mate Range



- A comprehensive range of silicone and water based sealants for a diverse range of jobs for internal and external applications
- Manufactured to ISO standards, quality products at affordable prices

Silicone & Acrylic Sealants

Product Codes Begin **BIBD** Product Group **95**



Article No.	Size	Description	Colour	Box Qty.	
BDBAWH	EU3	Bath & Kitchen Sealant	White	25	A

- Waterbased, cost effective solution for sealing around sanitary/bathroom items • Can be over painted



BDLEAD	EU3	Flash-Mate Lead Sealant	Grey	25	B
--------	-----	-------------------------	------	----	----------

- For sealing lead flashing to most substrates, including glass, glazing plastics, stone and brick • Fast surface cure

BDFMBR	EU3	Frame-Mate Sealant	Brown	25	C
BDFMWH	EU3	Frame-Mate Sealant	White	25	

- Suitable for most building substrates, except plastics • Use around windows and doors for an over paintable water tight seal



BDMBL	EU3	Multi-Mate GP Silicone	Black	25	D
BDMT	EU3	Multi-Mate GP Silicone	Translucent	25	
BDMBR	EU3	Multi-Mate GP Silicone	Brown	25	
BDMGR	EU3	Multi-Mate GP Silicone	Grey	25	
BDMWH	EU3	Multi-Mate GP Silicone	White	25	

- Sealing and waterproofing of high humidity areas • Remains flexible, has good adhesion to most plastics and paints

BDPMT	EU3	Pro-Mate LMA Silicone	Translucent	25	E
BDPMWH	EU3	Pro-Mate LMA Silicone	White	25	

- Suitable for sealing and glazing applications, where a waterproof application is required by the trade

BDUT	EU3	Ulti-Mate Neutral Cure Silicone	Translucent	25	F
BDUWH	EU3	Ulti-Mate Neutral Cure Silicone	White	25	

- Used on pre-cast concrete and brick work, ideal for expansion joints • Remains flexible for 25 years



Applicator Guns



Product Codes Begin **BIBD** Product Group **95**

Article No.	Size	Description	Box Qty.	
BDCG300	300ml	Economy Sealant Gun	24	A
BDCG400	400ml	Economy Sealant Gun	24	
BDHDG	400ml	Pro Plus Heavy Duty Gun	12	



A

Specialist Sealants Construction Adhesive



Product Codes Begin **BIBD** Product Group **95**



B

Article No.	Size	Description	Colour	Box Qty.	
BDAWSBL	EU3	Rain-Mate All Weather Sealant	Black	25	A
BDAWSCL	EU3	Rain-Mate All Weather Sealant	Clear	25	

• Adheres to all surfaces, even when wet • Remains flexible with age, can be over painted



C

BDGR	EU3	Roof & Gutter Sealant	Black	25	B
------	-----	-----------------------	-------	----	---

• Bitumen based product, can be applied to most materials • Ideal for gutter and drainage repairs, and felt overlapping



C

BDSN2	EU3	Saves Nails Express	Beige	25	C
-------	-----	---------------------	-------	----	---

• A DIY instant grab adhesive for most materials • Has gap fill usage and replaces need for standard fixings



D

BDOHC300	EU3	Caulk-Mate One Hour Decorators Caulk	White	25	D
----------	-----	--------------------------------------	-------	----	---

• Fast curing, gap filling to most materials • Retains some flexibility to account for movement, can be over painted



E

BDSVWH	EU3	GP200 General Purpose Silicone Sealant	White	25	E
BDSVBR	EU3	GP200 General Purpose Silicone Sealant	Brown	25	
BDSVT	EU3	GP200 General Purpose Silicone Sealant	Translucent	25	
BDSVBL	EU3	GP200 General Purpose Silicone Sealant	Black	25	
BDMWH	EU3	Multi-Mate GP Silicone	White	25	

• Fast curing general purpose silicone • Cost effective, contains a fungicide to delay mould growth in humid areas



F

WP70T	EU3	WP70 Neutral Cure Oxime Silicone	Translucent	25	F
-------	-----	----------------------------------	-------------	----	---

• Neutral cure exterior glazing silicone, suitable for all PVC and glass use (note: not bedding in) • 20 year life



Bond It Rescue Tape



Product Codes Begin **BIBD** Product Group **95**

Article No.	Description	Colour	Box Qty.	
BDRTBL	Rescue Multi Purpose Silicone Repair Tape	Black	12	A
BDRTCL	Rescue Multi Purpose Silicone Repair Tape	Clear	12	

- A self-fusing, silicone repair product with infinite uses
- Resists fuels, oil, acids, solvents, salt water, road salt and UV rays
- For repairing leaks on plumbing and hoses in a flash
- It can be used to insulate electrical wiring and it can withstand a constant working temperature of 200°C
- Simply stretch and wrap for a permanent seal

Bond It Premiere Range



- Trade grade silicones and foams for the professional user
- ISO approved, premium quality

Premier Silicone Sealants

Product Codes Begin **BIBD** Product Group **95**



A



B



C



D



E



F

Article No.	Size	Description	Colour	Box Qty.	
BDFWH	EU3	Fireshield AC Intumescent Acrylic	White	25	A

- Acrylic sealant for sealing most material joints where a fire resistant seal is required
- When subjected to heat product swells to give a smoke and fire resistant seal

BDHT30R	310ml	HT30 Heat Resistant Silicone	Red	12	B
---------	-------	------------------------------	-----	----	----------

- Will withstand temperatures up to 250°C • For use with joints of high temperature exposure i.e ovens and stoves

BDPU18BL	EU3	PU18 Sealant / Adhesive	Black	12	C
BDPU18GR	EU3	PU18 Sealant / Adhesive	Grey	12	
BDPU18WH	EU3	PU18 Sealant / Adhesive	White	12	

- Polyurethane adhesive & sealant, developed for the engineering, construction, automotive & marine markets
- Bonds most materials, giving a tough, elastic seal • Can be used to fix wooden doors

BDS3IV	EU3	S3 Sanitary Silicone	Ivory	25	D
BDS3T	EU3	S3 Sanitary Silicone	Translucent	25	
BDS3WH	EU3	S3 Sanitary Silicone	White	25	

- For sealing and providing a water resistant seal on most kitchen and bathroom areas • Contains a biocide to prevent mould growth

BDHA6T	310ml	HA6 Marine Silicone	Translucent	25	E
BDHA6WH	310ml	HA6 Marine Silicone	White	25	

- A high modulus, non shrinking, marine quality silicone sealant and adhesive
- Contains no fungicides or oils which may leach into water • Temperature stability: -60°C to +200°C

BDLN7T	310ml	LN7 LMN Silicone	Translucent	25	F
--------	-------	------------------	-------------	----	----------

- 100% neutral cure, pure silicone sealant • Gives off no solvents or corrosive vapours whilst setting



A

Polyurethane Foams & Applicator Guns



Product Codes Begin **BIBD** Product Group **95**



B

Article No.	Size	Description	Colour	Box Qty.	
BDFIX750	750ml	Fill and Fix Expanding Foam Aerosol	Beige	12	A
BDFIXG750	750ml	Fill and Fix Expanding Foam Gun Grade	Beige	12	B

• General purpose polyurethane foam • Yields 40 times can volume, making this a cost effective gap and fixing solution



C

BDCF1	500ml	Cleaning Fluid for Expanding Foam Gun		12	C
-------	-------	---------------------------------------	--	----	---

• Solvent cleaner for cleaning applicator guns • Simply screws on to gun and flushes out foam



D

BDEFR750	750ml	Fire Resistant PU Expanding Foam	Pink	12	D
BDEFRG750	750ml	Fire Resistant PU Foam Gun Grade	Pink	12	

• Highest B1 rated fire grade currently available in the UK

BDEF750	750ml	Mega Foam Gun / Aerosol Expanding Foam	Beige	12	E
---------	-------	--	-------	----	---

• Unique PU foam filling with a 360° application method, high dense building grade, yielding 30% more than standard foams



E

BDAG1	STD	Professional Gun Foam Applicator		1	F
BDAK45	STD	Heavy Duty Professional Foam Gun		1	G

• Teflon coated to facilitate easy cleaning after use



F



G



Bond It Adhesives & Glues



• A range of high performance adhesives for most interior and exterior building applications

General Building & Construction Adhesives

Product Codes Begin **BIBD** Product Group **95**



Article No.	Size	Description	Colour	Box Qty.	
BDA007	500ml	Aerosol Spray Adhesive		12	A

• General purpose spray contact adhesive, particularly good for carpet and floor tile applications, for spot fixing



BDAC1	1l	Contractors Grade PVA	White	12	B
BDAC5	5l	Contractors Grade PVA	White	4	

• All purpose trade adhesive and sealer for plaster and concrete



BDA001	500ml	Contact Adhesive	Beige	12	C
BDA002	1l	Contact Adhesive	Beige	12	

• High grab, with ability to allow repositioning • Bonds most materials • Not suitable for painted surfaces



BDA050	125ml	Duo 2 In 1 Wood Glue	White	24	D
BDA051	250ml	Duo 2 In 1 Wood Glue	White	12	
BDA052	500ml	Duo 2 In 1 Wood Glue	White	20	
BDA053	1l	Duo 2 In 1 Wood Glue	White	12	

• All in one wood adhesive suitable for both external and internal use, for use on all wood related products • DIN rated



BDMSPBL	EU3	GB Pro Hybrid Sealant & Adhesive	Black	12	E
BDMSPCL	EU3	GB Pro Hybrid Sealant & Adhesive	Crystal Clear	12	
BDMSPWH	EU3	GB Pro Hybrid Sealant & Adhesive	White	12	

• A hybrid polymer product that seals and fills • Gives high strength joints, remains flexible and clear

• Waterproof, can be applied in wet conditions • Can be painted over



BDGB12	350ml	Gripbond – Instant Grab Adhesive	Beige	12	F
--------	-------	----------------------------------	-------	----	----------

• A superior fixing grab adhesive that requires no fixings, anti slump, instant strong grab to all materials, along with gap fill properties

• Can be painted over



BDPGE	300ml	Saves Nails SF	White	25	G
-------	-------	----------------	-------	----	----------

• A solvent-free fixing/grab construction adhesive • Can be used with polystyrene as well as most building materials

BDEFMS	750ml	Mega Stik PU Adhesive	Beige	12	H
--------	-------	-----------------------	-------	----	----------

• Instant fix of plasterboards, one can fixes five boards • Use for timber, plaster, brick, stone and slate

• Quick dry • Use with standard foam applicator



BDA022	1l	PVA Adhesive & Sealer	White	12	I
BDA024	2.5l	PVA Adhesive & Sealer	White	4	
BDA023	5l	PVA Adhesive & Sealer	White	4	

• Premium quality PVA used to seal plaster/concrete • Quick dry, high bond strength, can be diluted four to one.



Bond It Adhesives & Glues

Industrial & Specialist Glues



Product Codes Begin **BIBD** Product Group **95**



A



B



C



D



E



F



G



H



I

Article No.	Size	Description	Colour	Box Qty.	
BIA7050	50ml	A70 Studlock	Red	15	A

• For locking and sealing of metal to metal joints that require a permanent joint

BIA4350	50ml	A43 Threadlock	Blue	15	B
---------	------	----------------	------	----	----------

• For those threaded joints that need a shakeproof fixing without the need for lock washers, but is removable

HVC1620	20g	Cyanoacrylate Superglue – Hi Viscosity	Clear	25	C
---------	-----	--	-------	----	----------

• For non porous surfaces, including PVC plastics, and gives gap filling properties for uneven surfaces

RGC2420	20g	Cyanoacrylate Superglue – Med Viscosity	Clear	25	D
---------	-----	---	-------	----	----------

• Fast fix to flat and even surfaces

BIMP400	400ml	Multi-Purpose Spray Lubricant	Clear	12	E
---------	-------	-------------------------------	-------	----	----------

• A high performance, high penetrating lubricant, with anti corrosive and water dispersant properties

BDAPU5	300ml	PU Wood Gel	Translucent	12	F
--------	-------	-------------	-------------	----	----------

• For strong rapid adhesion/gluing of wood based materials, resists acids, waterproof, even to sea water • Sets in five minutes

BDMI	200ml + 50g	Mitre Kit Adhesive	Clear	12	G
------	-------------	--------------------	-------	----	----------

• A high strength bonding system comprising cyanoacrylate adhesive and aerosol activator

BDAPU150	150ml	The Beast PU Adhesive	Brown	12	H
BDAPU250	250ml	The Beast PU Adhesive	Brown	9	
BDAPU500	500ml	The Beast PU Adhesive	Brown	6	

• Fast Drying • High bond strength • For ceramics, metal, stone, wood, glass & most plastics • Interior and exterior use • Waterproof

BDGMD3125	125ml	Glue Monster Wood Adhesive		12	I
BDGMD3250	250ml	Glue Monster Wood Adhesive		9	
BDGMD3500	500ml	Glue Monster Wood Adhesive		6	

• Fast Drying • Interior and exterior use • High bond strength • Waterproof



A

Bond It Tile Adhesives, Grouts & Fillers



- Ready mixed and cement based powder & grouts

Adhesives



B

Product Codes Begin **BIBD** Product Group **95**

Article No.	Size	Description	Colour	Box Qty.
BDTA01	7.5kg	Aqua-Tile	Off White	1
BDTA02	15kg	Aqua-Tile	Off White	1

A

- Ready mixed, easy application, non-slip, shower resistant, for use in power showers etc, when used with waterproof grout
- CE Approved. EN12004 D2



D

BDTA06	7.5kg	Supergrip	Off White	1
BDTA07	Trade Pack	Supergrip	Off White	1

B

- Ready mixed tile adhesive, high spread rate, shower resistant, high instant grab rate, cost effective every day use
- CE Approved. EN12004 D1T



E

BDRS20	20kg	Rapid-Set	Grey	1
--------	------	-----------	------	---

D

- Fast set tile adhesive for wall and floor tiles • Grouting can be applied 2-3 hours after application • For exterior or interior use
- Suitable for installations subject to occasional wetting eg domestic shower, saunas and bathrooms • CE Approved. EN12004 C1F

BDTRF	20kg	Rapid-Flex	Grey	1
-------	------	------------	------	---

E

- Rapid set, flexible floor and wall tile adhesive suitable for mosaics, porcelain and natural stone, having flexible properties
- Ideal for use on wood, timber panels, plywood etc, as well as impermeable surfaces • Interior and exterior use
- Can receive light foot traffic 2-3 hours after application • CE Approved. EN12004 C2F



F

Ceramic Tile Grouts

Product Codes Begin **BIBD** Product Group **95**

BDTA10	1.5kg	Fix 'N' Grout	Brilliant White	6
BDTA11	3.75kg	Fix 'N' Grout	Brilliant White	1

F

- Brilliant white adhesive and grout in one ready mixed tub • Suitable for all ceramic tiles and mosaics, can be used in showers
- CE Approved. EN12004 D2



G

BDFTG3	3kg	Floor Tile Grout	Grey	5
--------	-----	------------------	------	---

G

- For joints 3-12mm, easy smooth application with maximum spread • Sets to a hard durable finish



H

BDWTG4	3kg	Wall Tile Grout	High White	1
--------	-----	-----------------	------------	---

H

- For joints up to 3mm wide • Totally waterproof when set, can be used in swimming pools etc



Bond It Tile Adhesives, Grouts & Fillers

Decorators Fillers



Product Codes Begin **BIBD** Product Group **95**

Article No.	Size	Description	Colour	Box Qty.
BDLWF05	500ml	One Hit Wonder Lightweight Filler	White	12
BDLWF1	1l	One Hit Wonder Lightweight Filler	White	6

• Ultra light filler which gives superior non shrink gap fill properties on most surfaces, easy to sand to smooth finish • Over paintable



Bond It Builders Complete



• Ready mixed and cement based powder and grouts

Building Chemicals & Mixes

Product Codes Begin **BIBD** Product Group **95**



Article No.	Size	Description	Colour	Box Qty.
BDH080	2.5l	Brick & Patio Cleaner	Clear	4
BDH081	5l	Brick & Patio Cleaner	Clear	4

• Acid based powerful cleaner for all mortar splashes, grease and oil on brick and concrete



BDH020	5l	Integral Water Resistant Plasticiser	Pink	4
--------	----	--------------------------------------	------	---

• Gives waterproof resistance to cement when set • Ideal for external rendering applications • CE Approved. EN934-3

BDH070	5l	Mould-Stop!		4
--------	----	-------------	--	---

• Removes and eradicates organic growth • Effective on wood, concrete, plastic, stone and tarmac • Easy to use



Compounds



Product Codes Begin **BIBD** Product Group **95**

BDJC15	15kg	Wide Gap Allweather Jointfill – Paving Compound	Buff	1
--------	------	---	------	---

• Modern MS technology, gives a credible alternative to sand and cement grouting outside • Can be used in the wet



BDH100	10kg	Levelmaster Self Levelling Compound	Grey	1
--------	------	-------------------------------------	------	---

• Sets hard in 2-3 hours, can be trowelled to feather edge • Low odour • Covering can be laid 6-8 hours after application
• CE Approved EN19813 CT-C16-F

Bond It Builders Complete Cleaners



Product Codes Begin **BIBD** Product Group **95**



A



B



C



D



E



F



G



H



I

Article No.	Size	Description	Colour	Box Qty.	
BDC001	1l	Glass Cleaner	Clear	12	A

- Non smear formula, non smear finish

BDC002	1	PVCu Solvent Free Cream Cleaner	White	12	B
--------	---	---------------------------------	-------	----	---

- Non corrosive cream cleaner for those built in stains on PVC windows, baths etc

BDC003	1l	PVCu Fast Acting Solvent Cleaner	Clear	12	C
--------	----	----------------------------------	-------	----	---

- Low residue, general solvent cleaner for general PVC plastics.

BDC007	1l	Foilsafe Solvent Cleaner	Clear	12	D
--------	----	--------------------------	-------	----	---

- For use on foil covered PVC, where standard PVCu cleaners would react by lifting foils and damaging surfaces.

BDHW80	80	Multi-Wipes	White	8	E
--------	----	-------------	-------	---	---

- Removes most building related product, including paint, grease, silicone etc • Contains Aloe Vera skin care formula
- Anti-Bacterial action effective against E-Coli, MRSA, Salmonella & Listeria

Marking & Masking



Product Codes Begin **BIBD** Product Group **95**

BDDJ2	48mm	Drywall Scrim Tape – 90m	White	24	F
-------	------	--------------------------	-------	----	---

- Alleviates the need for pre-plastering, saving time and money

BIBDDT45S	45mm	Duct Tape – 50m	Silver	24	G
-----------	------	-----------------	--------	----	---

BIDDT45BL	45mm	Duct Tape – 50m	Black	24	
-----------	------	-----------------	-------	----	--

- A highly versatile tape that is strong and used for sealing, binding, repairing and joining a wide range of materials

BDLM001	750ml	Line It Line Marker Paint	Yellow	12	H
---------	-------	---------------------------	--------	----	---

BDLM002	750ml	Line It Line Marker Paint	White	12	
---------	-------	---------------------------	-------	----	--

BDLM003	750ml	Line It Line Marker Paint	Red	12	
---------	-------	---------------------------	-----	----	--

BDLM004	750ml	Line It Line Marker Paint	Blue	12	
---------	-------	---------------------------	------	----	--

BDLM007	750ml	Line It Line Marker Paint	Black	12	
---------	-------	---------------------------	-------	----	--

- Lead free marker paint, hard wearing and gives good UV stability

BDMT25	25mm	Masking Tape – 50m	Buff	36	I
--------	------	--------------------	------	----	---

BDMT38	38mm	Masking Tape – 50m	Buff	24	
--------	------	--------------------	------	----	--

BDMT48	48mm	Masking Tape – 50m	Buff	24	
--------	------	--------------------	------	----	--

BDMT75	75mm	Masking Tape – 50m	Buff	12	
--------	------	--------------------	------	----	--

- For use when decorating



Bond It Bitubond



• Bitumen solutions and paints for roofing applications

Bitumen Compounds & Paints

Product Codes Begin **BIBD** Product Group **95**



A



B



C

Article No.	Size	Description	Colour	Box Qty.
BDB026	2.5l	All-Weather Roofing Compound	Black	6
BDB027	5l	All-Weather Roofing Compound	Black	4

• Waterproof coating that can be applied in damp conditions, stable in cold and hot temperatures

BDB015	1l	Bitumen Paint	Black	6
BDB016	2.5l	Bitumen Paint	Black	6

• Paint for waterproofing and weather protecting steelwork and concrete • Apply by brush or spray

BDB000	1l	Felt Adhesive	Black	6
BDB001	2.5l	Felt Adhesive	Black	6

• Cold applied heavy duty adhesive for bonding bituminous roofing felts to asphalt, metal, felt and concrete

• Also bonds mineral chippings to bituminous surfaces • Apply by brush, mop or squeegee

Flashing Tapes



Product Codes Begin **BIBD** Product Group **95**



A

BDF002	75mm	Flashing Tape – 10m	Grey	8
BDF003	100mm	Flashing Tape – 10m	Grey	6
BDF004	150mm	Flashing Tape – 10m	Grey	4

• Crease resistant self adhesive flashing tape • For general repairs on roofs, parapits and chimney stacks

Bond It Xtreme Products



Product Codes Begin **BIBD** Product Group **95**



A

Article No.	Size	Description	Colour	Box Qty.
BDSANXWH	310ml	Xtreme Always White	White	12

• High quality anti-mould silicone that prevents mould growth for up to 10 years



Miscellaneous

Dust Sheets

Article No.	Description	Colour	Box Qty.	
V48041	Barrier Stair Runner 9m x 1m	Cloth	Blue	1
V48040	Barrier Dust Sheet 3m x 3m	Cloth	Blue	1
V47978	Harris 12' x 9' Cotton Twill Dust Sheet	Polyback	White	1
N39505	Light Protection Dust Sheet 3.2m x 3.2m	Clear Polythene	Clear	1



PVC Insulating Tape

Article No.	Description	Colour	Box Qty.
V48200	19mm x 33m	Black	8
V48201	19mm x 33m	White	8
V48202	19mm x 33m	Red	8
V48203	19mm x 33m	Blue	8
V48204	19mm x 33m	Green	8
V48205	19mm x 33m	Yellow	8
V48206	19mm x 33m	Green/Yellow	8
V48213	19mm x 33m	Grey	8
V48214	19mm x 33m	Brown	8

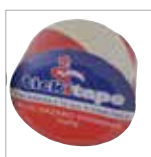

PVC Hazard Warning Tape



Article No.	Description	Colour	Box Qty.
V58783	33mm x 50mm	Red/White	1
V58786	33mm x 50mm	Yellow/Black	1



Self-Amalgamating Tape

Article No.	Description	Colour	Box Qty.
V58789	19mm x 10mm	Black	1



PTFE Tape



Article No.	Description	Colour	Box Qty.
581006	PTFE Tape Gas	White	10
V48209	PTFE Tape Air and Water	White	10

Parcel Tape Low Noise



Article No.	Description	Colour	Box Qty.
V58768	48mm x 66mm	Buff	1

Aluminium Tape



Article No.	Description	Colour	Box Qty.
V42268	Asl 252 Aluminium Foil Tape (40 microns)	Aluminium	1



NOTES

A large rectangular area defined by a dotted border, intended for writing notes.





NOTES

NOTES





NOTES

INDEX

A

Abracs	405-422
Abrasives	405-422
Abrasives Coated	418-421
AC90	423
Ace Hose Clips & Accessories	316
Acrylic Sealants	431-433
Action Can	423-429
Adhesive Bases (for Cable Ties)	313
Adhesives (Action Can)	428
Adhesives (Bond It)	435-437
Adjustable Field Gate Sets	351
Adjustable Shelving	361
Adjustable Surface Vents	267
Agricultural Ironmongery	351-353
All Thread Studs	54
Aluminium Clout Nails	133
Aluminium Letter Plates	393
Aluminium Lever Handles	385-387
Aluminium Pull Handles	385-387
Aluminium Tape	442
Aluminium Tile Pegs	134
Aluminum Nails	133 & 134
Angle Bracket (Building/Fencing)	306
Angle Brackets	55
Angle Brackets (Fluted)	367
Angle Cleats	298
Animal Bolts	344
Ankerbolts	198-200
Ankerbolt Drop In Setting Tool	201
Ankernuts	225
Annular Ring Shank Nails	126
Anti Vandal Screws	9
Antique Hinges	380
Applicator Guns	431
Arris Rail Brackets	302
Assembled HT Set, Nut & Washer	47
Automatic Gate Latches	345
Axle Pulleys	354

B

B2 & B3 Rated Expanding Foam	220
Backflap Hinges	376
Backing Pads (Abracs)	414
Bales Catches	392
Ball Bearing Hinge Brass	373
Ball Bearing Hinges	368
Ball Catches	392
Ball Chain	312
Ball Chain Fittings	312
Ball Race Door Gear	363
Barbed Wire	296
Barrel Bolts	339-340
Barrel Strainers	300
Base Plates	56
Basin Fixing Sets	228
Bathroom Mortice Lock	323
Bathroom Sealant	431
Bayonet Tacks	137
Belt Lubricants	425
Bent over Arms	298
Bigtwist Nails	217

Binx Nuts	69
Bitumen Compounds and Paints	440
Black Antique Hinges	380
Black Antique Letter Plates	394
Black Antique Lever Handles	385
Black Antique Pull Handles	387
Black Japanned, Round Head	7
Blindbolts	148
Blind Rivets	149-158
Blue Rosett Cavity Fixing (Trade Bag)	266
Blued Cut Tacks Pre-packed	137
Blued Fine Cut Tacks	137
Blow Out Pump	212
Bolt & Nut Cover Caps	91
Bolt Projecting Shield Anchors	206
Bolt Through Tubular Mortice Latch	324
Bolts (Retail Bags)	273 & 274
Bond It Range	431-440
Book Support	272
Bookcase Strip	357
Bookcase Studs	357
Bookends	366
Border Fence	292
Bow Handle Bolts	345
Bow Handles	386
Brackets & Plates	357 & 358
Brad Nails	127
Brads	132
Braided Rope	311
Brass Butt Hinges	371 & 372
Brass Counter Flap Catches	373
Brass Counter Hinges	373
Brass Dome Nuts	72
Brass Escutcheon Pins	137
Brass Fitch Fasteners	403
Brass Flat Washers	80
Brass Hexagon Full Nuts	63
Brass Hinges	373-375
Brass Letter Plates	393
Brass Lever Handles	384
Brass Locknuts (Half Nuts)	68
Brass Machine Screws	114-117
Brass Panel Pins	137
Brass Parliament Hinges	373
Brass Pull Handles	386 & 387
Brass Sash Fasteners	404
Brass Screw Cup	10
Brass Set Screws	41
Brass Studding	52
Brass, Countersunk Head	8
Brass, Raised Head	9
Brass, Round Head	8
Brenton Pattern Pad Bolt	340 & 341
Brick Raking Blade	414
Brick Ties	306
British Standard Mortice Locks	319
Briton Door Closers	396
BS3621 5 Lever Mortice Locks	319
BT Type 25 Thread Cutting Screws	24
Bugle Head Drywall Screws	17
Butterfly Hinges	380
Butt Hinges	369-371
Button Flange Socket Screw	106

C

Button Head Socket Screw	107
Buttons (Turn)	360
BZP Hose Clips	316
BZP Screw Eyes	271
Cabin Hooks	347-349
Cabinet Hinges	375
Cable Clips	313
Cable Ties	313
Cable Tie Wall Plug Box	313
Camplates	306
Canterbury Lever Handles	383
Cantilever Brackets	365
Capscrews	93-98
Carbine Hooks	312
Carcass Screws	9
Cartridge Tools	232
Casement Fasteners	402 & 403
Casement Stays	401 & 402
Cast Butts	370
Castors	362
Cavity Fixings	226
Cavity Fixings (Retail Bag)	282
Cavity Fixings by Lindapter	143
CE7 Hinges	368
CE11 Hinges	368
CE13 Hinges	368
Ceiling Hangers	232
Cementitious Grout	218
Centre Spur Wood Bits	241
Chain Accessories	311 & 312
Chain Bolts	344
Chain Link Fencing	292
Chain Lubricants	425
Chain Products Range	307-312
Challenge Tacks & Pins	137 & 138
Channel Accessories	55-57
Channel Nuts	57
Chest Handles	387
Chichester Lever Handles	382
Chippy Screws	6
Chippy Screws – Stainless Steel	7
Chrome Tubing	362
Clampack Fasteners	285-290
Clasp Nails	132
Cleaners (Action Can)	427
Cleaners (Bond It)	439
Cleaning Brushes	212
Cleat Hooks	354
Clothes Line Cleat Hooks	354
Clothes Line Pulleys	354
Clout Nails	123
Clutch Head Screws	9
Coach Bolts	49 & 50
Coach Screws	13
Coated Abrasives	418-421
Codelock Digital Door Locks	332
Collated Drywall Screws	19
Coloured Cover Caps	237
Compressor Oil	429
Concealed Hinges	374

Concrete Screws	27 - 30	Domecap Screw Covers (Trade Bag)	256	Exterior Screws	12
Concrete Screws	224	Dome Nuts	72	Extra Large Head Clout Nails	124
Cone Head Drive Screws	133	Dome Top Mirror Screws Pre-packed	286	Eye Bolts	207
Cone Point Setscrews	103	Dome Top Screws	12	Eye Hook	201
Cones	48	Domecaps	11	F	
Connecting Brackets	358	Domecaps Pre-packed	287	Fanlight Catches	404
Contact Adhesives	435	Door & Cupboard Catches	391 & 392	Fasteners Window	335
Continuous Hinges	381	Door Chains	336	Fastlatch	325
Copper Annular Ringshank Nails	134	Door Closers	396	Felt Adhesive	440
Copper Disc Rivets	113	Door Escutcheons	389	Felt Nails	124
Copper Slate Nails	134	Door Frame Cramps	305	Fencing	291-293
Copper Slate Straps (Retail Bag)	278	Door Hooks	354	Fencing Bolt-Down Support	301
Copper Strip Slate Clips	113	Door Kicking Plates	396	Fencing Concrete-In Support	301
Coppered Hardboard Pins Pre-packed	138	Door Knobs	388	Fencing Metalwork	297
Corner Braces	357	Door Numerals	395	Fencing Post Extender	301
Corner Brackets	357	Door Pulls	394	Fencing Repair Spike	301
Corner Plates	357	Door Security Bolts	334	Fencing Spike	301
Corner Straining Pillars	297	Door Springs	354	Fencing Stakes	298
Coronet Hinges	380	Door Stops	395	Fencing Staples	131
Corrosion Protection Fluid	429	Door Studs	347	Fencing U-Clip	301
Counter Flap Catch Brass	373	Door Viewers	336	Fencing Wire	293
Counter Hinges Brass	373	Double Action Spring Hinges	376	Fibre Discs	411
Countersunk Gutter Bolts & Nuts	112	Double Pressed Strong Butts	370	Fibre Washers	90
Countersunk Socket Screws	101 & 102	Double Sided Timber Connectors	89	Field Gate Catch	351
Crack Filler	219	Double Steel Washered Brass Butts	371 & 372	Field Gate Sets	351
Crack Stitch Twist Kit	218	Dowels	119	Fillers (Bond It)	438
Cranked Cabinet Hinges	375	Dowty Spat Roofing Washers	113	Fine Cut Tacks	137
Cross Bolts	343	Dowty Topats	113	Finger Plates	394
Cup Hooks Pre-packed	288	Draught Excluders	399	Finger Trowel	219
Cup Hooks (Retail Bags)	271	Drill Bits	239-243	Fire Door Hinges	368
Cup Point Setscrews	105	Drive Screws	133	Fire Stop Expanding Foam & Sealants	220
Cup Square Hex Bolts & Nuts	49 & 50	Drivefast Gas Nails	229 & 230	Fire Strips	398
Cup Square Hex Bolts & Nuts (Trade Bag)	257	Drop In Anchors	204	Fish Tail Frame Cramps	305
Cupboard & Door Catches	391 & 392	Dry Lubricants	425	Fitch Fasteners	404
Cupboard Knobs	388 & 389	Drywall Nails	125	Fixing Band-JCP	217
Cupboard/Turn Buttons	360	Drywall Screw	17	Fixing Band (Teco)	306
Curtain Wire Hooks & Eyes Pre-packed	289	Duckfoot	252	Flange Corner Brackets	358
Cut & Grind Discs	407	Duct Tape	439	Flange Nuts	70
Cut Clasp Nails	132	E		Flap Discs	410
Cut Floor Brads	132	Easy On Hinges	374	Flap Wheels	413
Cut Tacks	137	Easypost Bolt-Down Support	301	Flashing Tape	440
Cutting & Tapping Compound	428	Easypost Concrete-In Support	301	Flat Clips	314
Cutting Blades	408 & 409	Easypost Post Extender	301	Flat Corner Brackets	358
Cylinder Rim Nightlatches	328 & 329	Easypost Repair Spike	301	Flat Plate Hole Brackets	55
Cylinder/Door Pulls	394	Easypost Spike	301	Flat Point Setscrews	103
Cylinders	327, 331	Easypost System	301	Flat Washers Through Hardened Steel	83
D		Easypost U-Clip	301	Flat Wood Bits	241
D Handles	387	Ely Lever Handles	383	Fleur de Lys Hinge Front	380
D Shape Taper Washers	90	Emergency Exit Hardware	398	Fleur de Lys Hinges	380
Dead Locks	319-322	Emery Rolls	418	Floor Brads	132
Decking Fixings by Lindapter	147	Emery Sheets	418	Floor Fixings by Lindapter	147
Decking/Exterior Screws	12	Epoxy Acrylate Resins	210	Flush Hinges	375
Decorators Fillers (Bond It)	438	Escutcheon Pins	138	Flush Bolts	342
Dee Shackles	311	Escutcheons	389	Flush Pulls	387
Designer Lever Handles	383	ETA Approved Drop In Anchor	204	Flush Vents	361
Designer Turn and Release	390	Euro Cylinder Mortice Lock Cases	326	Fluted Angle Brackets	367
Detainer Mortice Locks	320	Euro Profile Cylinders	327	Folded Eye Bolts	300
Diamond Cutting Blades	414	Exeter Lever Handles	383	Folding Door Gear	363
Digital Door Locks	332	Expanded Metal Sheets	307	Foot Bolts	343
DIN 125A Washers	78	Expanding Foam	220	Form A Washers (Trade Bag)	258
Disc Rivets	113	Expanding Foam Applicators/Guns	434	Form B Washers	79
Dog Point Setscrews	104	Expanding Foams	220		

INDEX

F continued

Form C Washers	79
Form E Washers	90
Form G Washers	81
Frame Cramps	305
Frame Fixings	222
Frame Ties	306
Full Nuts	59-63
Furniture Screws	9

G

Garage Door Bolts	344
Garage Door Holders	344
Gas Nails	229
Gate Fittings	351 & 352
Gate Hooks & Eyes Pre-packed	289
Gate Latches	345
Gate Springs	354
General Purpose Silicone	220
General Purpose Woodscrews	6
Georgian Brass Lever Handles	384
Gerrard Hog Rings	299
Gimp Pins	138
Glass Plates	359
Glass Plates (Retail Bag)	278
Gravel Board Clips	302
Grease	423
Green PVC Wire Netting	291
Grey Shelf Brackets	367
Gussett Base Plate	55
Gutter Bolts & Nuts	112

H

Half Nuts	68
Hammer Drive Screws	26
Hammer Screws	221
Hand Pads	412
Hand Wipes (Action Can)	428
Handles Lever	381
Handles Pull	386 & 387
Handrail Brackets	355
Handymesh Panels	294
Hank Rivet Bushes	74
Hardboard Nails	129
Hardboard Pins Pre-packed	290
Hasp & Staples	349-351
Hat & Coat Hooks	355
Heavy Cross Bolts	344
Heavy Duty Anchors	208 & 209
Heavy Duty Screws	15
Heavy Duty Woodscrews (Retail Bag)	272 & 273
Heavy Duty Woodscrews (Trade Bag)	256
Heavy Pattern Table 3 Washers	81
Heavy Pattern Table 4 Washers	82
Heavy Reversible Hinges	378
Heavy Welded Mesh	295
Heico Lock Washers	87
Hereford Lever Handles	383
Herringbone Joist Struts	304
Hexagon Bolts	31 - 46
Hexagon Full Nuts	59-63
Hexagon Full Nuts (Trade Bag)	258

Hexagon Head Self Tapping Screws	23
Hexagon Set Screws	31 - 46
Hexagon Washer Head Screws	23
Hexagon Wrench Sets	110
Hexagon Wrenches	109
High Tensile Hexagon Bolts & Sets	31 - 46
High Tensile Hex Sets - Cone Point	57
High Tensile Sets (Trade Bag)	257

Hinge Bolts	334
Hinges	368-382
Hinges Black Antique	380
Hip Irons	306
Hog Rings	299
Holding Down Bolts & Nuts	48
Hole Cleaning Brushes	212
Hole Cleaning Pumps	212
Hole Saws	415
Hollow Wall Anchors	226
Hook & Band Hinges	379
Hook Bolt	201
Hook Bolts & Nuts	112
Hook on Plate	352
Hook Only on Plate	378
Hook to Bolt	379
Hook to Drive	379
Hooks & Eyes	118
Hose Clips	316
Hot Bed Handles	386
Housing Ties	306
HSS Drill Bits	241 & 242
Hurlings	375

I

Indented Hexagon Head Self Tapping Screws	23
Indicating Bolts	390
Injection Resin Accessories	212
Injection Resins	210
Injection Tools	212
Insulation Fixings	284
Intermediate Standards	297
Internal Letter Flap	393
Internal Threaded Sockets	215 & 216
Intumescent & Acoustic Mastic	220
Intumescent Strips	398

J

J-Fix Capsules	215
J-Fix Studs	213 & 214
Jigsaw Blades	416
J-Plug Plasterboard Fixings	225
Jack Chain	310
Jagged Nails	125
Jointing Blocks	278
Joint Plates	56
Joist Hangers	303
Joist Struts	304
Jubilee Hose Clips	318

K

Kick Over Stable Latch	353
Kicking Plates	396
Kit-MASTER – Assorted Kits	155-160
Kitchen Cupboard Hinges	375

Kliplock	314
Knee Rail Straps	304
Knobs (Door & Cupboard)	338 & 339
Knockdown Blocks (Retail Bag)	278
Knurled Cup Point Setscrews	106
Kwixset	216

L

Landscape Fabric	295
Landscape Screws	15
Lateral Restraint Straps	305
Lath Nails	125
Leak Detector Fluid	429
Legs for Worktop	367
Letter Plates	393
Lever Handles	381-385
Lichfield Lever Handles	381
Lift Off Butts	370
Light Duty Fixings (Retail Bag)	280 & 281
Light Pattern Table 3 Washers	82
Light Steel Butts	369
Lindapter	139-148
Line Marker Paint (Action Can)	426
Line Marker Paint (Bond It)	439
Line Pulleys	354
Line Wires	293
Lock Washers	85
Locking Bars	351
Locking Gate Catch	352
Locking Window Stays & Fasteners	335
Locknuts (Half Nuts)	68
Locks for PVCu Doors	335
Loft Door Latch	392
London Pattern Shelf Brackets	367
Loose Bolts	207
Loose Bolt Shield Anchors	207
Loose Pin Butts	370
Lost Head Round Wire Nails	122
Louvre Flush Vents	361
Lubricants	423

M

M Hooks	118
M Hooks Pre-packed	288
Machine Screws	114-117
Machine Screws Pre-packed	287
Machine Screws (Retail Bags)	276
Magazine Pins	231
Magnetic Catches	391
MAP Products	361 & 362
Masking Tape	439
Masonry Anchors	27 - 30
Masonry Drill Bits	240
Masonry Nails	137
Masonry Nail Pipe Clips	314
Mending Plates	357
Mesh Panels	294
Metal Anchors (Retail Bags)	
Metal Anchors (Trade Bags)	264
Metal Cutting Discs	405-408
Metal Dowels	119
Metal Expansion Plug	223
Metal Grinding Discs	405-408

Metal Plasterboard Fixings (Trade Bag)	266	Panel Pins	128	Q	
Metal Washered Pins	231	Panel Pins Pre-packed	290		
Metalfix Self Drilling Screws	233	Panic Hardware	398	Quadrant Stays	401-403
Metalwork for Fencing	297 & 298	Parcel Tape	442	R	
Metolux Wood Filler Products	430	Parliament Hinges Brass	373		
Mirror Plates	11	Parliament Hinges Steel	376	Rabbit Netting	291
Mirror Screws	12	Patio Door Locks	334	Rack Bolts	334
Mitred Brackets	365	Penetrating Oil	423	Ranch Door Hinges	376
Mixing Paddle	219	Piano Hinge	381	Razor Wire	296
Modesty Blocks	358	Picture Hook Pins Pre-packed	289	Rebate Sets	328
Modesty Blocks (Trade Bag)	263	Picture Hooks Pre-packed	289	Rebated Mortice Locks	322
Monkey Tail Bolts	344	Picture Wire Pre-packed	289	Rebated Tubular Mortice Latch	326
Mortice Knobs	388	Pins	128 & 129	Recip Saw Blade	416
Mortice Latch	324	Pins (Retail Bags)	277	Red Oxide Primer	426
Mortice Lock Cases	326	Pins (Trade Bags)	259-263	Reeled Chain	309
Mortice Locks	319-322	Pipe Caps	308	Reinforced Cantilever Brackets	365
Mudguard Washers Carton & Small Box	83	Pipe Clip Reducer	314	Rescue Tape	432
Mudguard Washers (Trade Bag)	258	Pipecovers	314	Resins	210 & 211
Mushroom Head Roofing Bolts & Square Nuts	112	Pipe Nails	132	Restraint Straps	305
Mushroom Head Roofing Screws	112	Pipe Spacer	314	Retail Packs - Unifix	268-284
		Plain Cantilever Arms	55	Reversible Hinges	378
N		Plasterboard Fixings	225	Ridge Plates	357
Nail In Anchors	227	Plastic Chain	309	Right Angle Hole Brackets	55
Nail Plates	306	Plastic Coated Wire Pipe Caps	309	Rim Cylinders	331
Nails	120-136	Plastic Headed Nails	227	Rim Knobs	338 & 339
Nails (Retail Bags)	277	Plastic Toggles	226	Rim Locks	330 & 331
Nails (Trade Bags)	259-263	Plastic Wall Plugs	223	Rim Nightlatches	328
Necked Barrel Bolts	340	Plate Washers	48 & 86	Ring Gate Latches	346
Necked Tower Bolts	338	Plates & Brackets	357 & 358	Ring on Plate	352
Netting	291	Pliers For Wire Netting Fasteners	299	Ring Shank Nails	126
Netting Fasteners	299	Plugs (Retail Bag)	281	Rising Butts	371
Netting Stakes	298	Plustops	11	Riveting Tools	154
Netting Staples	138	Plustops Pre-packed	287	Rivets	149-154
Nightlatches	329	Poastal Knocker Letter Plates	393	Road Fixing Kit	225
Numerals	395	Pointing Gun	219	Rochester Lever Handles	382
Nuts	59-73	Polybag and Minibag Range - JCP	244-251	Rockite	216
Nuts (Retail Bags)	274	Poly Discs & Wheels	412	Roller Catches	392
Nylon Frame Fixing	222	Polyester Resins	211	Roofing Bolts & Nuts	112
Nylon Insert Nuts	64-66	Polyester Styrene Free Resins	211	Roofing Bolts & Nuts (Trade Bag)	257
Nylon Insert Nuts Type P (Trade Bag)	258	Polypropylene Rope	310	Roofing Bolts Pre-packed	144
Nylon Nail Plugs	221	Polytop Nails	136	Roofing Felt Adhesive	440
Nylon Sleeve	212	Polyurethane Foam Applicators/Guns	434	Roofing Nails	133
Nylon Wall Plugs	223	Polyurethane Foams	434	Roofing Nuts	68
Nylon Wall Plugs (Trade Bags)	265	Post Shoes Heavy Duty Galvanised	302	Roofing Screws	112
Nylon Washers	91	Pre-cut Chain	308	Roofing Washers	43
		Pre-pack Fasteners	285-290	Rope	310
O		Press Locks	331	Rope Grips	312
Option 1 Approved Ankerbolt	200	Pressure Plugs	111	Rosett Cavity Fixings	226
Option 1 Approved Throughbolt	196	Professional Woodscrews – Ulti-Mate	3	Round Soffit Vents	361
Option 7 Approved Throughbolt	196	Professional Woodscrews – Vortex	1	Round Wire Nails	120 & 121
Outside Tap Cover	399	Profile Cylinders	225	S	
Oval Brad Nails	127	Projecting Bolt	206		
Oval Cylinder Mortice Lock Cases	326	PTFE Tape	442	S Hooks	32
Oval Cylinders	327	Pull Handles	386 & 387	Saddle Bolts	50
Oval Link Chain	310	Pulleys	354	Safety Hasp & Staples	349
Oval Pad Bolts	341	Pure Epoxy Resins	210	Sanding Belts	419
		Purlin Clips	56	Sanding Discs	420
P		Push Plug	223	Sandpaper Sheets	419
PA97	232	PVA Adhesives	435	Sandpaper Rolls	419
Pad Bolts	341	PVC End Caps	57	Sanitary Fixings	228
Padlock Protection Bars	351	PVC Hazard Tape	441	Sanitary Fixing Packs (Retail Bags)	279
Padlocks	332			Sanitary Sealant	431-433
Paints (Action Can)	426			Sapphire Shelving	365-367

INDEX

S continued

Sash Cord	312	Slotted Woodscrews	7-9	Stainless Steel Pin Hexagon Self Tapping Screws	193
Sash Fasteners	403	Slotted Woodscrews Pre-packed	285	Stainless Steel Polytop Nails	136
Sash Lifts	404	Socket Bolts	201	Stainless Steel Range of Fasteners	161-194
Sash Locks	319-322	Socket Capscrews	93-99	Stainless Steel Round Wire Nails	135
Sash Pulls	387	Socket Countersunk Screws	101 & 102	Stainless Steel Self Tapping Screws AB Point	164-167
Satin Finish Paint	426	Socket Screws & Wrenches	93-111	Stainless Steel Serrated Flange Nuts	176
Scaffold Ring Bolts	205	Socket Shoulder Screw	108	Stainless Steel Set Screws	169 & 170
Screed Netting	291	Soffit Vents	361	Stainless Steel Shakeproof Washers	180 & 181
Screw Cover Caps	11	Solid Drawn Brass Butts	371	Stainless Steel Slate Hooks	113
Screw Cups	10	Solstuds	138	Stainless Steel Socket Screws & Wrenches	182-186
Screw Cups Pre-packed	286	SP Clampack Range of Fasteners	285-290	Stainless Steel Spring Washers	179
Screw Eyes	118	Spare Line Wires	293	Stainless Steel Square Nuts	175
Screw Eyes Pre-packed	288	Spat Roofing Washers	113	Stainless Steel Studding	172
Scrim Tape	439	Spear Hinges	380	Stainless Steel Studding Connectors	173
Scroll Hip Irons	306	Spin in Capsules	215	Stainless Steel Supertite Screws	167 & 168
SDS Drill Bits	239 & 240	Spindle Mounted Flap Wheels	413	Stainless Steel Table 3 Washers Light Pattern	180
Sealant Guns	431	Spindle Mounted Wheels	413	Stainless Steel Tamper TX Bit	194
Sealant Remover	431	Spirabands	366	Stainless Steel Tamper TX Key	194
Secondary Security	330 & 331	Spring Field Gate Sets	352	Stainless Steel Tamper TX Machine Screws	194
Security Bolts	334	Spring Hinges	373	Stainless Steel Tamper TX Self Tapping Screws	193
Selacovers	113	Spring Hooks	312	Stainless Steel Two Pin Bits	191
Selawashers	113	Spring Loaded Animal Bolts	340	Stainless Steel Two Pin Machine Screws	190
Self Amalgamating Tape	441	Spring Rod Bookends	272	Stainless Steel Two Pin Self Tapping Screws	191
Self Clinching Fasteners	75-77	Spring Toggles	226	Stainless Steel Wing Nuts	176
Self Drilling Drywall Screws	17	Spring Washers	84	Stainless Steel Woodscrews	161-163
Self Drilling Screws	26	Springhead Roofing Nail	129	Stakes	298
Self Drilling Screws-JCP	233-239	Square Book Support	366	Staple on Plate	352
Self Drilling Screws (Retail Bags)	283 & 284	Square Hardboard Nail	129	Staples	131
Self Drilling Screws (Trade Bags)	266 & 267	Square Hooks Pre-packed	289	Star Dowels	119
Self Locking Gate Catch	352	Square Plate Washers	48 & 86	Stays Window	401 & 402
Self Tapping Screws	20-23	Square Plates for Monkey Tail Bolts	345	Steel Butts	369-371
Self Tapping Screws (Retail Bags)	272	Square Roofing Nuts	70	Steel Rising Butts	371
Serrated Lock Washers	85	Square Square Holding Down Bolts & Nuts	48	Steel Shelves	365
Set Screws	101-108	Square Twisted Nails	130	Steel Veneer Pins Pre-packed	290
Shackles	311	Square Weld Nut	71	Steel Washered Brass Butts	372
Shear Nuts	50	Squire Padlocks	333	Steelwork Fixings	139-142
Shelf Brackets	365 & 366	Stable Latch	353	Stitching Bar & Accessories	219
Shelf Ends	366	Stainless Steel Annular Ring Shank Nails	135	Stock Fence	294
Shelf Supports (Retail Bag)	278	Stainless Steel Cleaner	424	Stone Cutting Discs	405-407
Shelves	366	Stainless Steel Clout Nails	135	Stone Grinding Discs	405-407
Shelving	365 & 366	Stainless Steel Coach Screws	171	Stormguard Draught Excluders	399
Shield Anchors	206 & 207	Stainless Steel Cup Square Bolts Only	171	Stormproof Hinges	376
Shock Cord Assemblies	311	Stainless Steel Dome Nuts	175	Straining Eye Bolts	300
Shot Fired Pins	231	Stainless Steel Flat Washers	178	Straining Eye Bolts (Retail Bag)	278
Shouldered Cup Hooks Pre-packed	288	Stainless Steel Form A Washers	177	Straining Pillars	297
Signs	394	Stainless Steel Form B Washers	177	Strap Hinges	378
Silicone Sealants	431	Stainless Steel Form C Washers	178	Straps (Restraint)	305
Silicones (JCP)	220	Stainless Steel Hexagon Bolts	168	Stretcher Bar Sets	297
Single Coil Spring Washers	84	Stainless Steel Hexagon Full Nuts	173	Stretcher Plates	358
Single Sided Timber Connectors	89	Stainless Steel Hexagon Shear Nuts	176	Strong Steel Butts	371
Sisal Rope	310	Stainless Steel Hexagon Weld Nuts	176	Struts	304
Slab Nails	130	Stainless Steel Hinges	368 & 369	Studding	51 - 53
Slate Clips	113	Stainless Steel Locknuts	175	Studding Connectors	53
Slate Hooks	113	Stainless Steel Lost Head Round Wire Nails	135	Suffolk Latches	346
Sleeper Screws	15	Stainless Steel Machine Screws	187-190	Superglue	436
Sleeve Anchors	202 & 203	Stainless Steel Mudguard Repair Washers	179	Supertite Trilobular Threadforming Screws	25
Slide Bolts	342	Stainless Steel Nails	135 & 136	Support Fixings by Lindapter	145 & 146
Sliding Door Gear	363	Stainless Steel Nylon Insert Nut	174	Surface Pattern Screw Cups	10
Slik Sliding Door Gear	363	Stainless Steel Panel Pins	136	Surface Screw Cups Pre-packed	286
Slot/Trickle Vents	361	Stainless Steel Pin Hexagon Bits	192	Surface Slide Bolts	342
		Stainless Steel Pin Hexagon Keys	193	Swivel Spring Hooks	310
		Stainless Steel Pin Hexagon Machine Screws	192		

T

T Bolt Clamps	317
Table 7 Washers	89
Table 8 Washers	89
Table Stretcher Plates	354
Tacks	138
Tail Bolts	344
Tap Covers	399
Taper Pressure Plugs	111
Taper Washers	90
Tee Head Bolts	50
Tee Hinges	367
Tee Plates	358
Terminal Straining Pillars	297
Thread Cutting Screws	25
Threaded Rod	53 & 54
Through Bolts	195
Throw Over Gate Loops	352
Thumb Latch	347
Thumb Turn Cylinders	327
Thumbscrews	118
Thunderbolt	27 - 30
Tile Adhesives	437
Tile Grouts	437
Tile Guard and Brackets	307
Tile Pegs	121
Timber Connectors	89
TimberDrive Screws	15
Timbermate Wood Filler	430
Toilet Roll Holders	358
Tool Kit PA97	
Toothed Lock Washers	85 & 86
Topats	113
Torx Drivers	201
Touch Latch	390
Tower Bolts	337-339
Trade Packs-Unifix	255-267
Trickle Vents	361
Trimfence	292
Truss Clip	304
Tube & Accessories	362
Tubular Handles	386
Tubular Mortice Latch	324-326
Turbo Diamond Blades	360
Turn and Release	390
Turn Buttons	360
Turned Pattern Screw Cuos	10
Twin Slot Shelving	365
Twinwik Woodscrews	5
Twinthread Woodscrews	5
Twist Nails	217
Twistec Screws CE Marked	16
Twisted Nails	130
Two-Way Straining Pillars	297
Tying Wire	293
Type P Nylon Insert Nuts	64-66
Type T Nylon Insert Nuts	64-66

U

Ulti-Mate Cases & Assortments	4
Ulti-Mate Woodscrews	3

Unequal Hinges	380
Universal Plugs	223
Uniwall Kits	306

V

VE4 ST Steel Type 4 Housing Ties	306
Veneer Pins	129
Vents	361
Vertical Flange Clip	224
Vertical Hasp & Staple	350
Vertical Restraint Straps	305
Victorian Brass Lever Handles	384
Vine Eyes	118
Vine Eyes to Drive	119
Vynylester Fast Cure Winter Grade	211
Vynylester Resins	210
Vortex Professional Woodscrews	1
Vortex Woodscrews (Retail Bags)	268

W

W.C Fixing Sets	228
Wafer Head Drywall Screws	18
Wall Plugs	223
Wall Starter Kits	306
Wall Ties	306
Wardrobe Door Gear	363
Wardrobe Hooks	354
Wardrobe Tube & Accessories	362
Warm Roof Fixings	218
Washed Brass Butts	371
Washerhead Slab Nails	130
Washers	78-86
Washers (Retail Bags)	275 & 276
Waterproof Paper Sheets	418
Waxed Cones	48
Wedge Nuts	57
Weld Nuts	70
Welded Chain	309 & 310
Welded Eye Bolts	300
Welded Mesh	294 & 295
Welding Spray	429
Wells Lever Handles	381
Westminster Duo Tone Lever Handles	383
Wet & Dry Paper Sheets	345
Winders	298
Window Accessories	401-404
Window Beam Clamp	56
Window Fasteners	403
Window Locks/Bolts	334
Window Stays	401-404
Window Stays & Fasteners (Locking)	335
Wing Nuts	73
Wire Brushes	422
Wire Cup Brushes	422
Wire Hand Brushes	422
Wire Hasp & Staples	350
Wire in Coils	293
Wire Lath Nails	125
Wire Mesh Sleeve	212
Wire Netting	291
Wire Netting Fasteners	299
Wire Pipe Nails	132

Wire Rope	311
Wire Rope Grips	312
Wire Wool	421
Wood Adhesives	435
Wood Filler Products Metolux	430
Woodfix Self Drilling Screws	234
Woodscrew Accessories	270
Woodscrews (Retail Bags)	268 & 269
Woodscrews (Trade Bags)	255
Woody Joist Hangers	303
Worktop Jointing Bolts (Retail Bag)	279
Worktop Legs	367
Workwear	PPE
Wrench Sets	110
Wrenches	109

X

Xtreme Products (Bond It)	440
---------------------------	-----

Z

Z Connecting Brackets	358
-----------------------	-----

0 - 9

104 Hurlinges	375
105 Flush Hinges	375
106 Solid Drawn Brass Butt	372
115 Heavy Duty Brass Butt	372
1838 Light Steel Butts	369
1840 Loose Pin Butts	370
1951 Stormproof Hinges	376
2 Lever Mortice Locks	322
200 Cast Butts	370
3 Lever Mortice Locks	321
400 Backflap Hinges	376
451 Strong Steel Butts	371
457 Lift Off Butts	370
466 Steel Rising Butts	371
488 Steel Parliament Hinges	376
5 Lever Mortice Locks	319
899 Double Pressed Strong Butts	370

E&OE.



Extratec Progressive Limited
8 Harbour Court
Heron Road Airport Road West
Belfast
BT3 9HB

Web: Extratec.co.uk Tel: 028 90457467 Fax: 028 9045 0353 Email: info@extratec.co.uk