

# MP551 Timber Frame Cavity Barrier

## Installation Guidelines

### COMPRESSION

Barriers are to be installed under the required level of compression:

- 15mm compression (50mm to 150mm cavities) or
- 20mm compression (151mm to 175mm cavities)

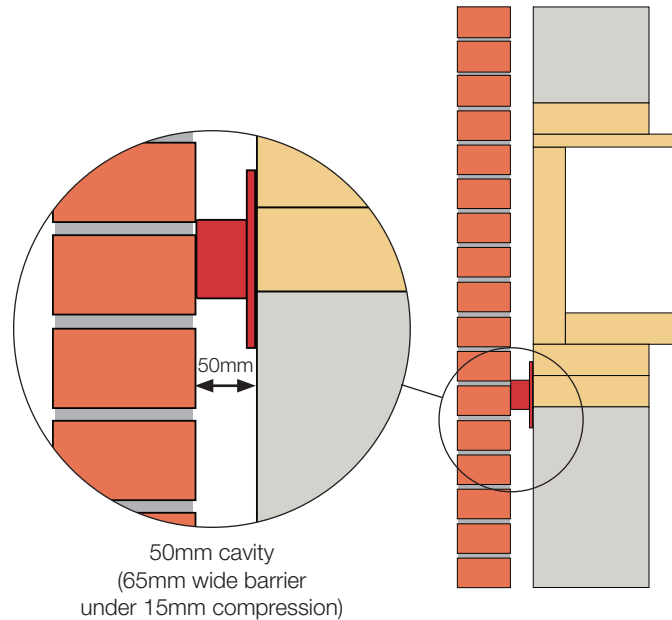

### CUTTING

When cutting barriers to size (along the length of the barrier) the steps detailed in the following guide are to be observed:

This example is for a 65mm wide x 65mm high barrier (i.e. 50mm cavity) being required at 800mm long

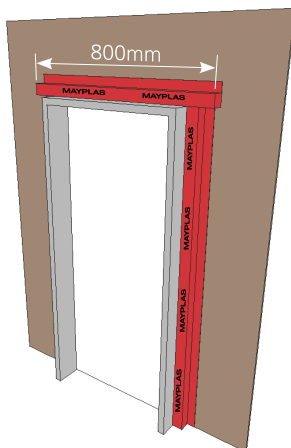

- 1 Create a slit at the end of the polythene sleeve

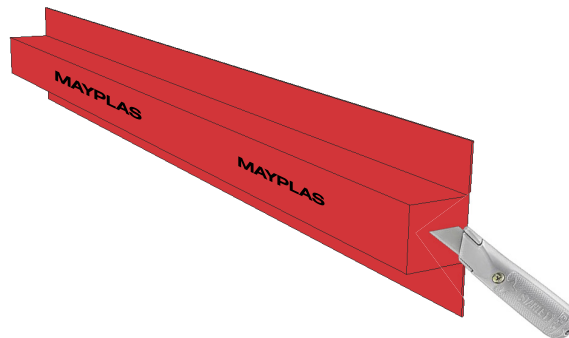

- 2 Carefully remove the mineral fibre core of the barrier

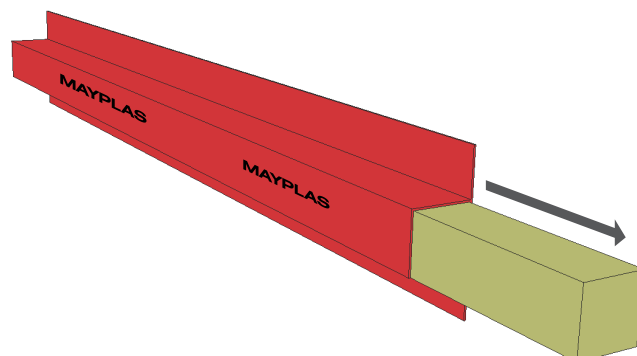

- 3 Trim to the required length (800mm)

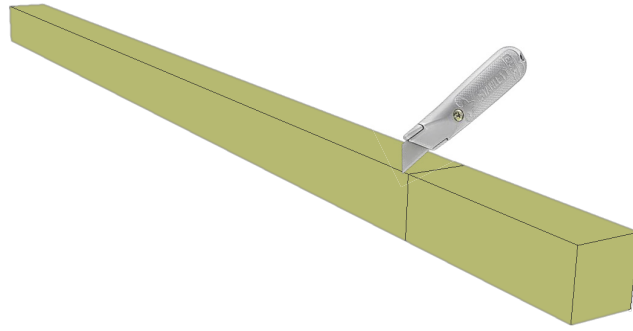

- 4 Once the mineral fibre core is correctly trimmed, re-insert back into the polythene sleeve

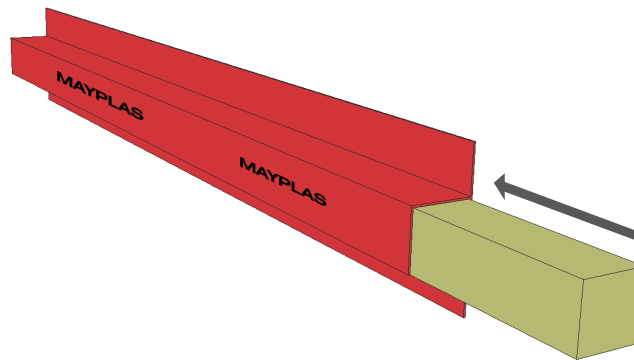

- 5 Cut the polythene sleeve approx. 100mm longer than the required barrier length (i.e. 900mm)

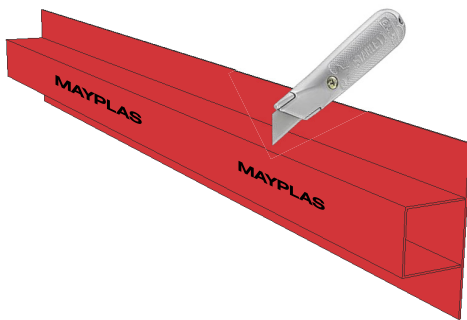

- 6 Fold the overlap of polythene (100mm) around the rear of the barrier flange / wing

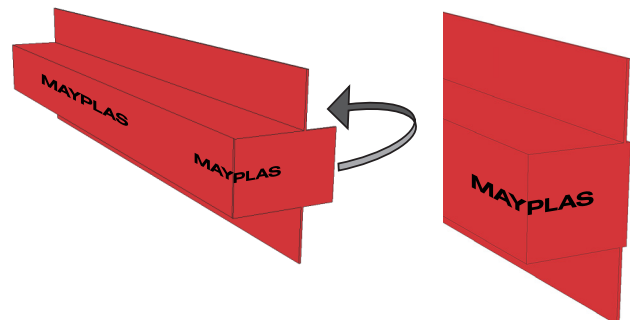

- 7 Locate a staple through the flange / wing at the location overlap during installation or seal the overlap to the rear of the flange / wing using a suitable tape

- 8 If using tape, ensure this does not compress or deform the mineral fibre element inside the barrier

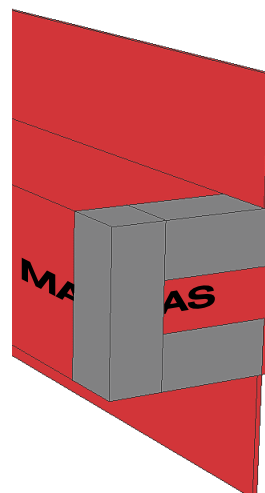

Rather than cutting barriers to size, for example around a window frame, it may be more cost effective to install an 'oversail' end to the barrier at the corner locations. This will not only ensure a tight butt joint is achieved but eradicate the need to cut the horizontal barriers to size.

**300mm Mayplas MP551**  
Barrier ends are sealed by the production process

**300mm Mayplas MP551**  
cut tightly into the vertical infill

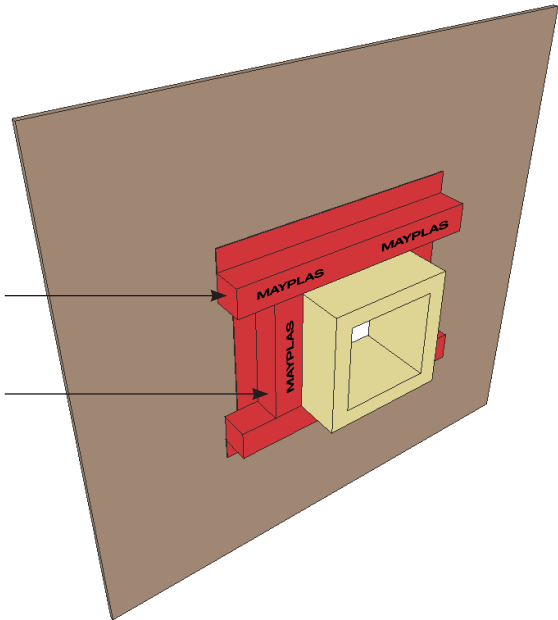

## DO'S and DON'TS

DO NOT 'chamfer' corners at 45°

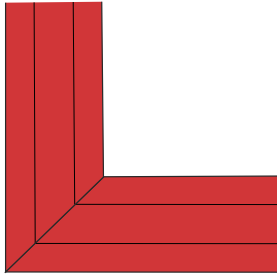

DO ensure tight 90° butt joints at corners

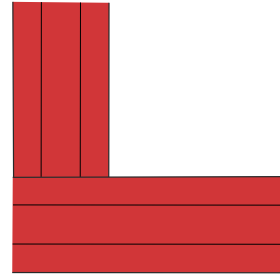

DO NOT bend a barrier to get it round a corner

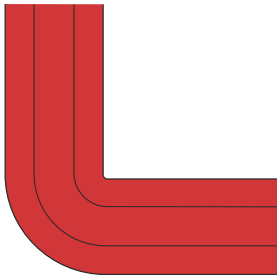

DO ensure that cavity barriers are tightly fitted and the compression obtained matches the requirements of the cavity barrier.

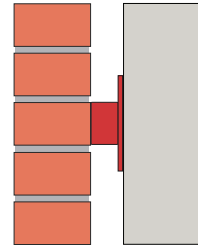

DO NOT allow gaps between barriers

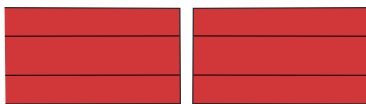

DO ensure that cavity barriers are fixed at a maximum of 150mm centres

