

Kronobuild® OSB3 T&G Flooring Products

THE STRONGER, LIGHTER, THINNER ALTERNATIVE

OSB3 is a structural, load bearing T&G board ideal for flooring and roofing- and it's readily available right now. At an 18mm thickness it's stronger, lighter and thinner than the alternatives, and it's easy to work with and quick and easy to install. There is also our Fast Clean OSB3 T&G flooring that benefits from a protective coating layer that peels off at the completion of the build, and our handy loft boards, again a structural load bearing product. They have all the major approvals and certification required and they're ready now for immediate delivery. To order your free samples, email: sales@kronospan.co.uk or visit:

www.kronospan-express.com

- Acoustic Compliance for flooring use
- BBA certified 4-sided T&G Flooring
- BBA certified Fast Clean (Weatherproof for 60 days)
- NHBC approved for use over 600mm joist spacing
- Flooring panel size: 2400 x 600mm
- Loft panel size: 1220 x 300mm
- Made from sustainably sourced wood
- FSC® and PEFC® certified
- 100% recyclable
- Quick and easy installation
- Zero-added formaldehyde



Kronobuild® OSB3 T&G Flooring Fitting Recommendations

Kronobuild® OSB 3 T&G is available in 18mm.

Use Kronobuild® OSB 3 T&G in domestic applications with a joist / batten spacing of 600mm.

OSB boards must always be laid so that the higher strength of boards (main axis, the longitudinal direction boards) is in the direction perpendicular to the joists.

01. STORAGE

Following delivery, boards should be stored in a dry/covered building on a flat floor.

Conditioning of the boards should take place in the area and atmospheric conditions in which they will be installed. Allow 2-3 days for conditioning.

Store boards with spacers to allow free air movement to both faces. Store on level bearers to preserve board flatness.

02. PRE-INSTALLATION CHECKS

Always ensure that the building is weathertight before installing the floor i.e. roof on and windows and doors fitted, this is a NHBC requirement.

Plan carefully for all pipes and other services and provide full support on all sides as shown below (Please see diagram A).

Kronobuild® T&G Flooring must be installed with the black ink marking on the underside. Ensure the joints match together securely.

Remember to protect your Kronobuild® T&G Flooring boards before, during and after installation.

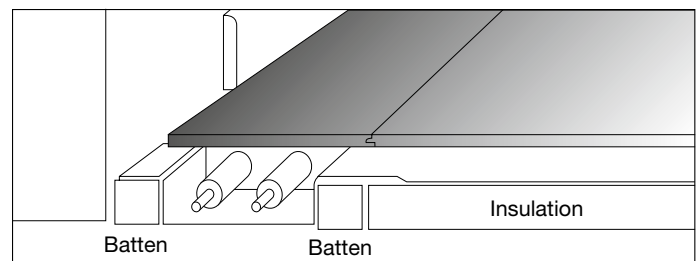

A. Correct fitting of Kronobuild® T&G Flooring over pipes and services.

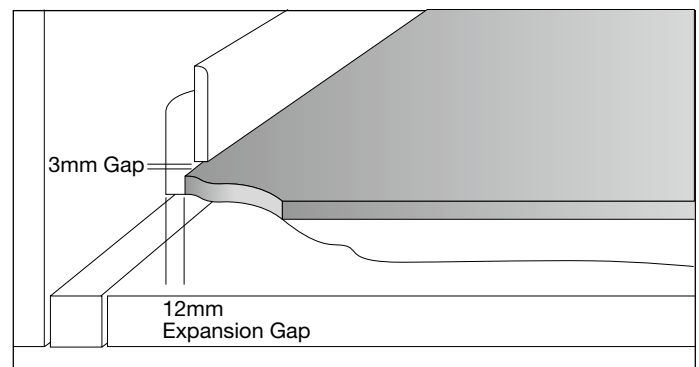

B. Expansion gap requirements

03. MOVEMENT & EXPANSION

These guidelines apply to joisted floors.

Allow a clear movement gap of 2mm per metre run of floor at each wall and an absolute minimum gap of 10mm at each wall. Gaps should be left around rigid upstands including pipes (see diagram B).

For floors where the movement gap cannot be dealt with at the perimeter alone or which are in excess of 6 meters long, e.g. corridors, intermediate expansion gaps (minimum 12mm), should be incorporated. Expansion gaps can be hidden at door thresholds (see diagram C).

Do not allow the movement gap to be obstructed with debris and maintain perimeter gaps using packers or wedges. Remove immediately after adhesive has set.

Protect the floor from wet trades and any water spillage at all times. In areas with higher than average temperatures, e.g. nursing homes, hospitals, etc. it is vital that careful attention is given to conditioning. Ensure heating is increased gradually. There is a greater risk of board shrinkage so movement provision may have to be adjusted accordingly.

04. JOISTED FLOORS

Joists should be installed as recommended in BS5268 (see diagram D).

In battened/joisted floors the boards are laid with the long edge across the supporting batten/joist. Short joints should be staggered and supported along the centre line of a batten/joist.

Where joints do not coincide with a joist, they must be supported by a separate noggin, in accordance with NHBC requirements.

All joints must be glued with a suitable adhesive, which should be liberally applied to coat both surfaces of the tongue. Gluing will strengthen the joint and reduce the risk of squeaking. PVAC adhesive to durability class D3 of BS EN 204:1991 is recommended.

Only flat headed annular ringshank, or other improved nails with superior holding power and corrosion resistance should be used. Four nails at equidistant centres should be used on each short joint, 25mm from short edge. Minimum nail length should be 2.5 times the board thickness and the minimum diameter should be 3mm. All nail heads should be punched home. Using No.8 Particleboard screws, the minimum screw length should be 2.5 times the board thickness or 50mm whichever is greater.

05. FINISHING

Vinyl flooring or carpet may allow the board / joints to telegraph through and will tend to show small irregularities in a floor's surface. Where necessary, it is acceptable to sand off any raised joints before covering the floor.

Where vinyl coverings are used, a thin wood based panel overlay e.g. 4mm plywood, should be fixed in position, staggering joints so as not to coincide with those of the T&G Flooring.

GENERAL PROPERTIES

Please refer to the DoPs on our website:

uk.kronospan-express.com/en/express-services/downloads

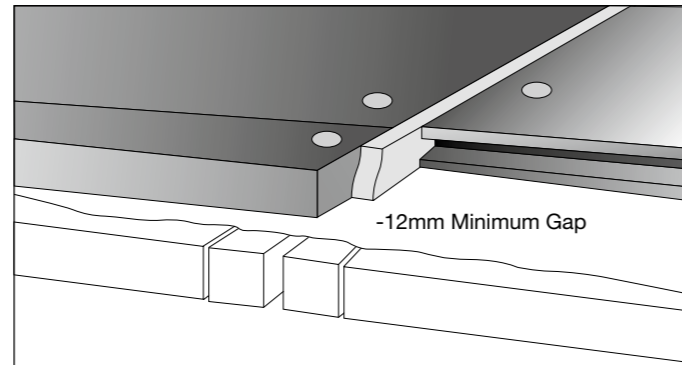

C. Intermediate expansion gap

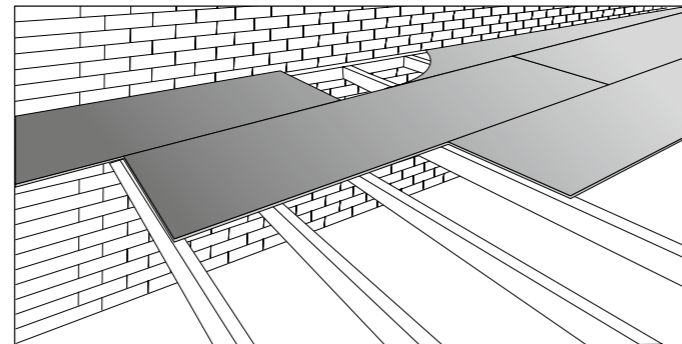

D. Kronobuild® T&G Flooring installed on joists

Kronobuild® Fast Clean OSB3 T&G Fitting Recommendations

1. Using Kronobuild® specially formulated D4 Adhesive lay two 6mm beads to the top of the joist the first boards are to be fitted to.

2. Mechanically fix the first row of boards over the joist using a fixing not less than 2 ½ times the thickness of the board. Apply Kronobuild® D4 Adhesive along the open edge profile and joists in readiness for the next board to be fitted.

3. Apply Kronobuild® D4 Adhesive along the full length of both the tongue and groove profile as boards are fitted. The joints should be securely bonded when the boards are interlocked.

4. Repeat the application steps on subsequent rows of boards which should be laid in a staggered pattern. Short end joints, including perimeter edges, must fall on a secured joist or noggin. The boards must be fixed at the rate of three per board (i.e., one at each end and one in the middle). This nailing pattern gives a mechanical fixing every 1200 mm along each joist. Any excess adhesive should be left to dry then removed at the end of the build process. If in doubt consult NHBC guidelines.

5. Use Kronobuild® specially formulated D4 Adhesive or Kronobuild® reinforced weather resistant tape to seal cut edges, perimeter edges, stairwells and mechanical fixing heads to reduce the risk of moisture ingress.

6. Once the construction is completed, weatherproofed and all decorating work is finished the flooring can be cleaned simply by peeling back the protective film slowly and steadily from the shortest edge.

STORAGE AND CONDITIONS

Boards should be stored properly stacked, out of contact with the ground and protected from the weather. They should not be laid in wet conditions or onto wet joists. A constructed floor, correctly installed, will have satisfactory resistance to weather and can be left exposed for up to 60 days. Adhesives and adhesive tape should be stored at room temperature and protected from frost. Seek specialist advice before fitting underfloor heating systems.

JOIST CENTRES

18mm panels can be used on joist centres up to 600mm in domestic situations.

EXPANSION PROVISION

Gaps must be left around the perimeter of the room to allow for expansion (either 10mm or 2mm per 1 metre run of floor whichever is greater).

With floors longer than 6 metres we would specify intermediate movement gaps of at least 10mm.

ADHESIVE COVERAGE

A 1 litre bottle of Kronobuild® D4 Adhesive should be enough to fix seven standard boards. Kronobuild® D4 Adhesive **MUST** be used to ensure BBA requirements are met.

TAPE COVERAGE

Rolls	Coverage	No. boards
1 x 25m	Perimeter edges only	16
1 x 25m	Perimeter edge & joints	5

MECHANICAL FIXINGS

For 18mm boards mechanical fixing should be a minimum of 2.8mm diameter and minimum 50mm in length.

Board thickness	18 mm
Minimum Fixing Length	50 mm
Minimum Fixing Diameter	2.8 mm

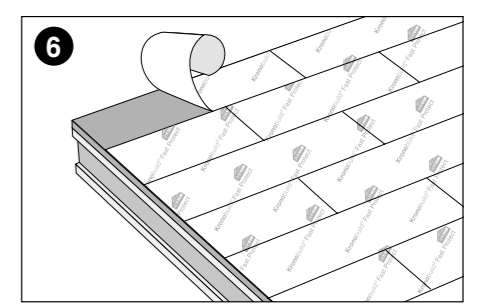
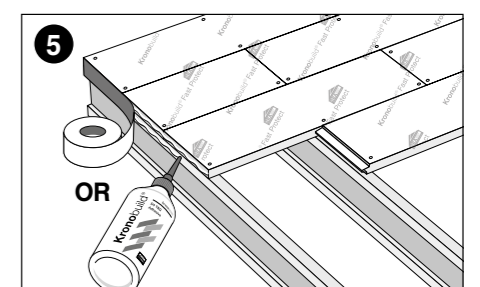
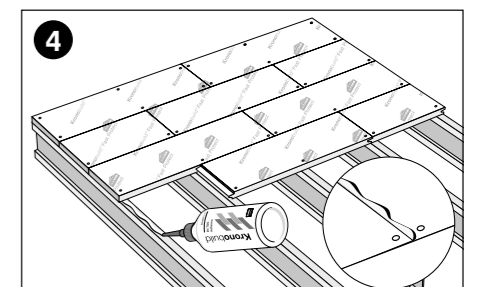
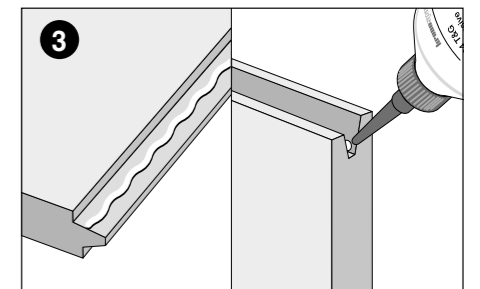
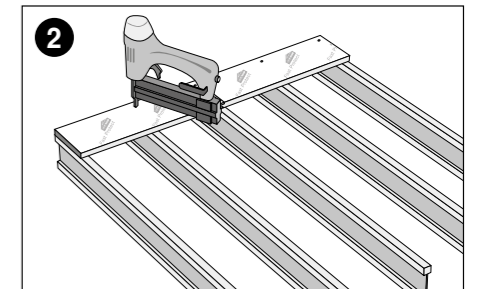
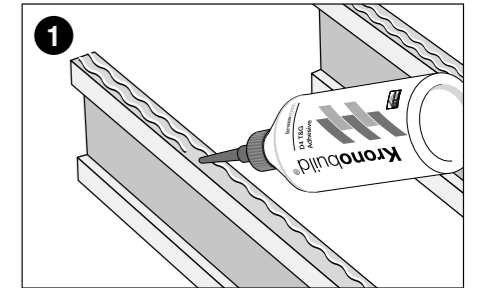

Mechanical fixing pattern for 2400 mm x 600 mm boards fixed to joists.

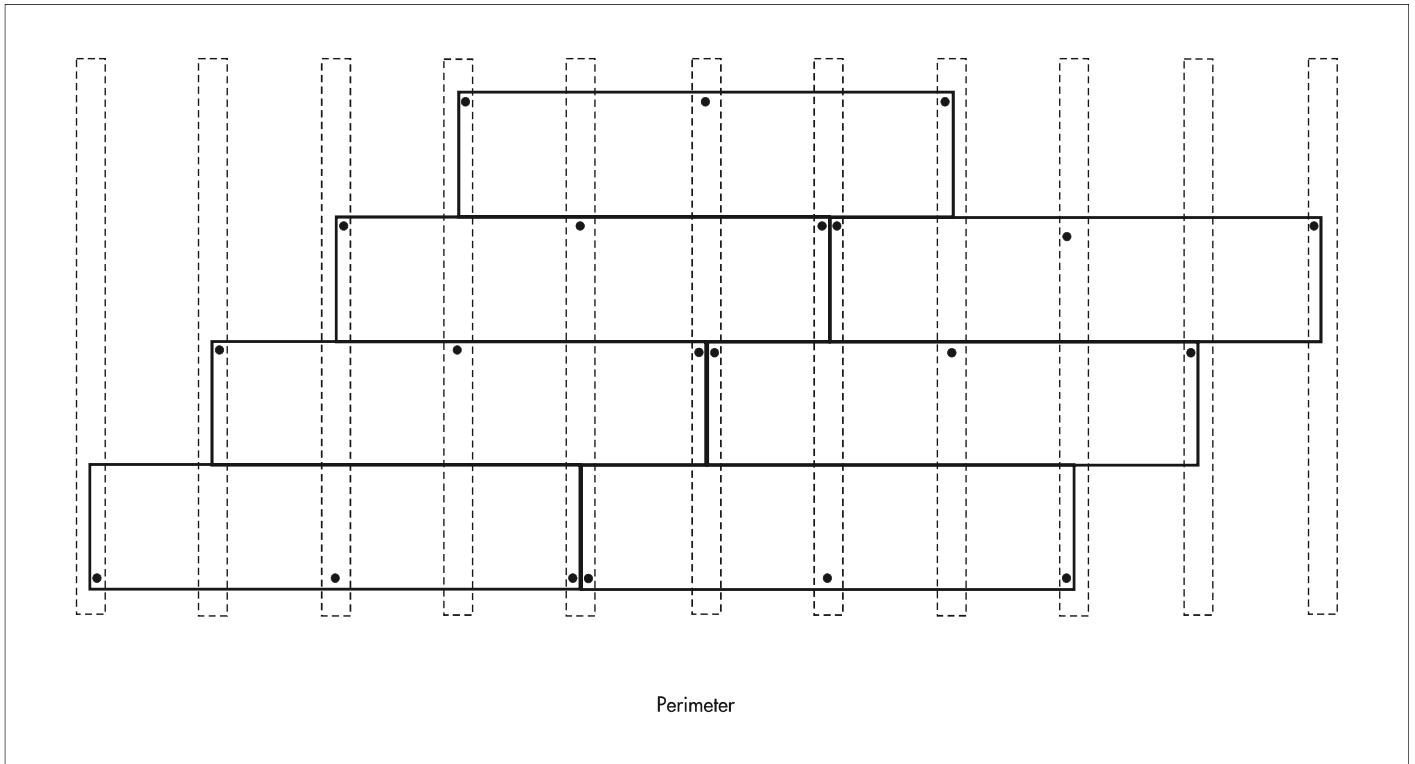

KRONOBUILD® T&G FLOORING HELPLINE

If you have any further questions about Kronobuild® T&G Flooring or encounter problems during installation, call our Customer Services Department on: 01691 775 229.



Cert. No. 2238



OSB3 T&G Flooring



OSB3 T&G Fast Clean

