



LCB700 Blue Flame oil boilers

Blue flame - bright future



0344 332 23 23
info@navienuk.com
sales@navienuk.com
service@navienuk.com
www.navien.co.uk

Building 2, Ground Floor, Guildford Business Park, Guildford, GU2 8XH



Installer's guide

welcome to Navien

We have been designing and manufacturing reliable and easy to install products for over 40 years, making Navien the fourth largest global boiler manufacturer. From the latest oil and gas-firing technology, to micro-CHP and solar, we are committed to developing highly efficient heating equipment.



World's largest facility

Our state-of-the-art facility in Seotan, South Korea, is the world's largest boiler manufacturing plant, with an annual capacity of 2 million units. We utilise the latest research and development, along with high-tech manufacturing methods to deliver heating products of unrivalled quality, unbeaten performance and with superb reliability over their lifetime.

Why choose Navien?



2 million produced a year
We produce 1.8 million gas and electric appliances and 200,000 oil boilers per year.



Low NOx emissions
Class-leading levels that are fit for the future.



A+ energy rating
All Navien products deliver the highest levels of efficiency.



Blue flame technology
Proprietary blue flame technology designed specifically to work with Navien boilers.



Lightweight
LCB700 Blue Flame weighs only 67kg making for ease of installation.



Peace of mind guaranteed
10 Year warranty straight from the box



Before leaving our factory, every boiler undergoes a thorough, two-stage testing procedure. This includes a specialised robotised process that carries out 55 quality checks per second. In addition, each unit receives a full working test by an operative, who completes a further 250 quality checks, ensuring all Navien Blue Flame boilers are of the highest standard.



Conformal coated waterproof PCB board

We design and manufacture our boiler components to the highest standards to deliver reliability and maximum performance.

Navien Blue Flame boiler range

Combi



System



Regular



LCB700 Blue Flame Combi

A standout unit that pushes the boundaries of condensing Blue Flame boiler technology.

Features & benefits:

- Internal and external models
- Stainless steel heat exchanger
- Class leading energy efficiency
- Flexible installation options
- Achieves highest 3-star mark in DHW performance (in accordance with EN Regulations)



LCB700 Blue Flame System

An exceptional boiler with a range of pioneering design features.

Features & benefits:

- Internal and external models
- Class leading energy efficiency
- Stainless steel heat exchanger
- Lightweight design for easy installation



LCB700 Blue Flame Regular

An easy to install boiler upgrade for older systems.

Features & benefits:

- Internal and external models
- Class leading energy efficiency
- Stainless steel heat exchanger
- Lightweight design for easy installation



SMART FORECAST CHECK

A heating system that can check the weather forecast and adjust itself accordingly.

Come rain or shine, our boilers will respond intuitively to the current weather conditions with Smart Plus.** When connected to WiFi, our LCB700 Blue Flame boilers check the forecast on OpenWeatherMap, ensuring a property maintains a comfortable temperature, and the boiler only uses energy when needed.



**Requires Navien Smart Plus and a WiFi connection.

BLUE FLAME

Leading the way towards a cleaner and more sustainable future.

In the coming years, blue flame is set to replace yellow flame in all oil boilers. Navien's revolutionary blue flame technology guarantees superior efficiency and ultra-low NOx emissions, resulting in a more economical, future-proof boiler.

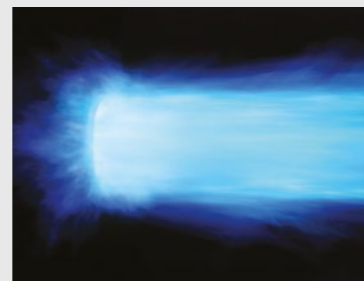

GEOFENCING CAPABILITIES

Let location take care of the heating system, with Smart Plus.**

By connecting an LCB700 Blue Flame boiler to a smartphone, the heating system will turn on and off based on an occupant's proximity to home. It can also be set up with multiple users so everyone in the household benefits from maximum comfort.



COST SAVING

Installation



Saving
£70

Warranty



Saving
£375

60/100 plastic flue

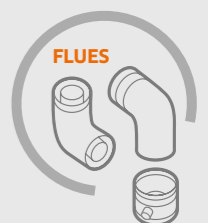

Saving
£140

Combi



Blue flame burner

Navien's blue flame burner emits extremely low NOx emissions of 57mg/kWh, providing a market leading and future proofed standard.



Gear pump

Discover the UK's first A+ rated oil boiler range

Our new LCB700 Blue Flame range of oil boilers is the first in the UK market to offer an A+ energy rating, thanks to an exceptional design and the latest smart control systems.*

Combined with easy to install features, such as a combined PRV/condensate drain and flexible pipework arrangements, the LCB700 Blue Flame is a boiler like no other.

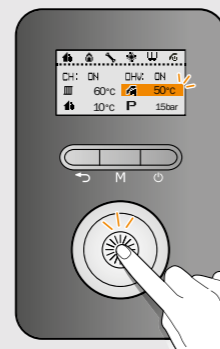

Hot water temperature control

Patented technology that delivers outstanding performance.

Navien's patented temperature control technology provides accurate adjustment of LCB700 Blue Flame hot water temperatures to within 1°C (30-60°C). This allows the boiler to achieve the highest 3-star mark in DHW performance (in accordance with EN Regulation (EN13203-1)* 1 of DHW performance assessment).

Take a look inside

COMBINED PRV AND CONDENSATE DRAIN

A clever design makes installation and ongoing maintenance simple, without compromising performance.

DE-AERATOR READY

A built-in two pipe oil system allows for simple conversion from a one pipe oil system.

SMART DISPLAY PANEL

Fitted in both internal and external models, Navien's intuitive built-in smart display makes it easy for everyone to get the most from their boiler.

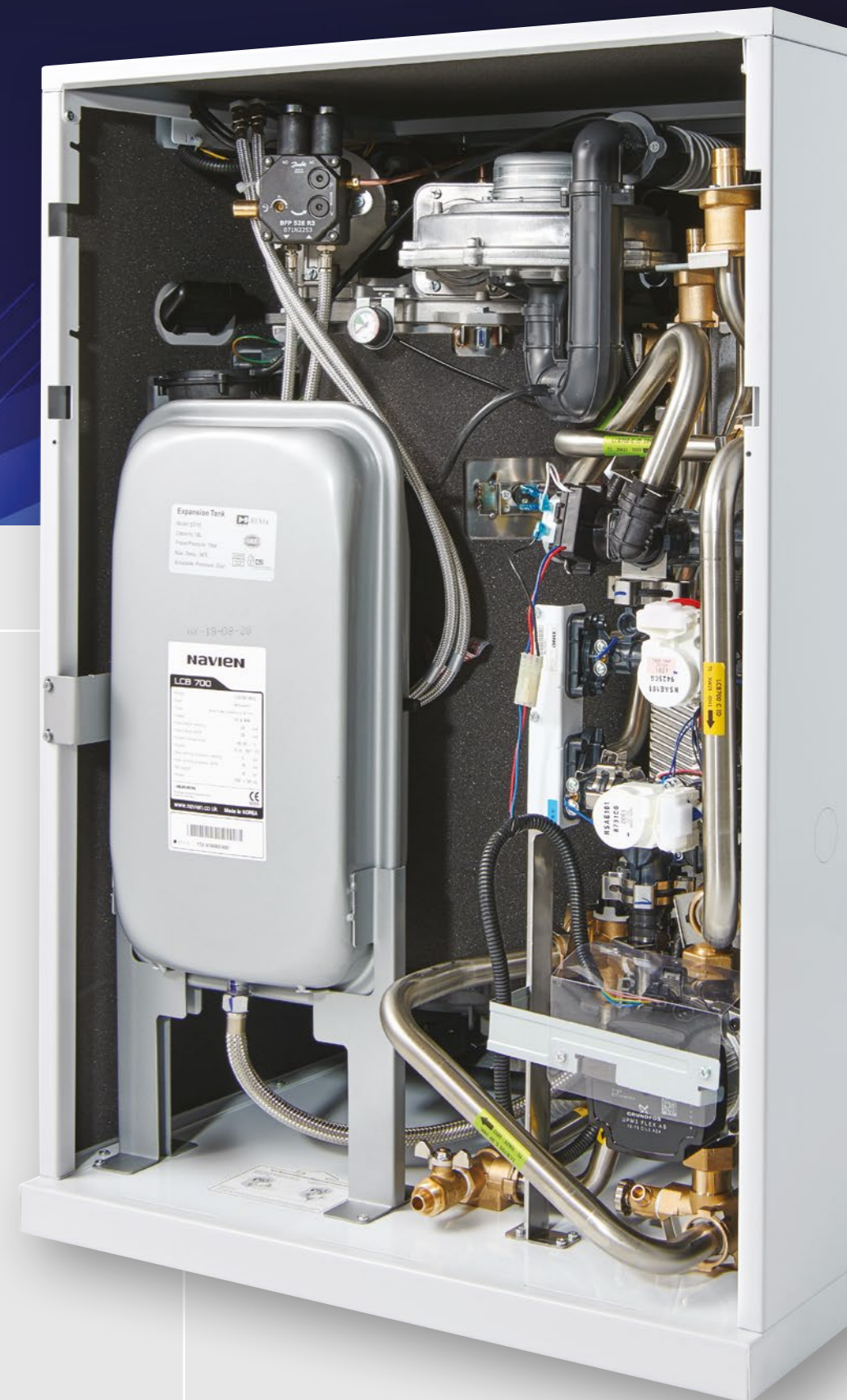

*An A+ energy rating is achieved when installed with 3 Smart Plus room thermostats.

Combi



The LCB700 Blue Flame range benefits from Navien's latest heat exchanger technology, which maximises heat transfer for superb efficiencies. Plus, by utilising high quality stainless steel, the heat exchanger is resistant to surface corrosion, maintaining its performance for the lifetime of the boiler.



Navien stainless steel heat exchanger

- Outputs of 15-21, 22-29 and 29-36kW
- The only boiler with A+ energy rating*
- Class leading NOx emissions
- 10 year guarantee as standard
- Clean and modern design
- Built-in control with easy programming and diagnostics
- Compatible with standard flues

Consistent flow temperatures

Avoid cold showers when someone turns on a tap! Thanks to a built-in Smart Auto Mixing and a Smart Auto Flow Control Valve, the LCB700 Blue Flame delivers consistent flow temperatures across multiple outlets.

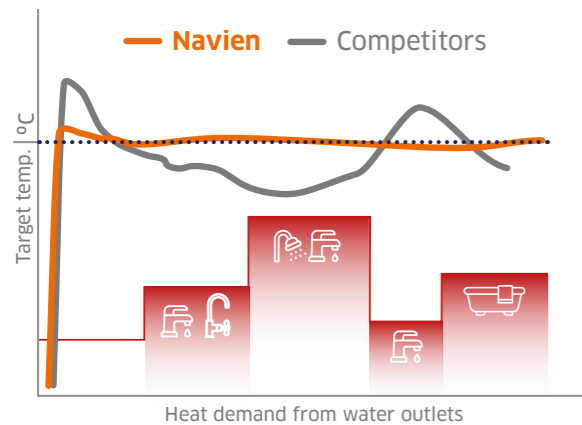

The text driven built-in control unit allows management of hot water temperatures accurate to 1°C (30-60°C).

See page 12 for more information.

* An A+ energy rating is achieved when installed with 3 Smart Plus room thermostats.

Internal



External



Technical data

		Internal Model			External Model		
		21	28	36	21	28	36
		RS / LS / LC	RS / LS / LC	RS / LS / LC	RSX / LSX / LCX	RSX / LSX / LCX	RSX / LSX / LCX
Heat Output	80/60°C	16/21kW	21/28kW	29/36kW	16/21kW	21/28kW	29/36kW
	50/30°C	23.0kW	30.3kW	39.0kW	23.0kW	30.3kW	39.0kW
DHW (Combi only)	Maximum Flow Rate (±15%)	14L/min	18L/min	20L/min	14L/min	18L/min	20L/min
	DHW Control Range	30-60°C (Default 50°C)					
	Maximum hot water temperature rise for 90 litres draw off (@max flow rate)	40°C					
Flue	Flue Size	Coaxial Plastic Ø 60/100					
	Max Horizontal Length	20m					
	Max Vertical Length	21m					

Dimensions	Regular/System Model	470 x 600 x 860mm			515 x 673 x 882mm		
	Combi Model	600 x 600 x 860mm			650 x 673 x 900mm		
Weight	Regular	58kg	59kg	62kg	64kg	65kg	68kg
	System	66kg	67kg	70kg	72kg	73kg	76kg
	Combi	91kg	92kg	95kg	98kg	99kg	102kg

ErP Efficiency	ErP A (93%)					
ErP Efficiency with Smart Plus (x3)	ErP A+ (98%)					
EN Regulation (EN13203-1)*	★★★					
NOx Emission Rate	57.2mg/kWh	57.2mg/kWh	63.2mg/kWh	57.2mg/kWh	62.5mg/kWh	63.2mg/kWh

* An A+ energy rating is achieved when installed with 3 Smart Plus room thermostats.

System

LCB700 Blue Flame System

Suitable for all sizes of home with a pressurised system, this boiler offers complete flexibility for all installations.

Features & benefits:

- Internal and external models
- High efficiency circulating pump
- Combined pressure relief valve and condensate drain
- Blue flame technology for maximum efficiencies
- 10 year guarantee
- Factory fitted expansion vessel
- Perfect height for installation between kitchen or utility units

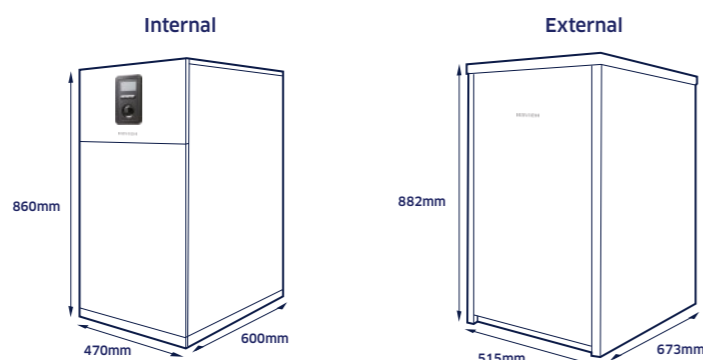

Regular

LCB700 Blue Flame Regular

Ideal for upgrading traditional systems, this boiler is well suited to larger households with multiple bathrooms.

Features & benefits:

- Internal and external models
- Blue flame technology for maximum efficiencies
- Built-in control panel for easy setup and programming
- 10 year guarantee
- Perfect height for installation between kitchen or utility units

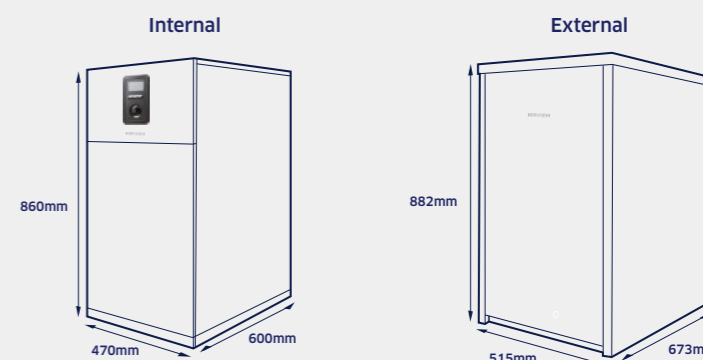

Technical data

		Internal Model			External Model		
		21	28	36	21	28	36
		RS / LS / LC	RS / LS / LC	RS / LS / LC	RSX / LSX / LCX	RSX / LSX / LCX	RSX / LSX / LCX
Heat Output	80/60°C	16/21kW	21/28kW	29/36kW	16/21kW	21/28kW	29/36kW
	50/30°C	23.0kW	30.3kW	39.0kW	23.0kW	30.3kW	39.0kW
Flue	Flue Size	Coaxial Plastic Ø 60/100					
	Max Horizontal Length	20m					
	Max Vertical Length	21m					

Dimensions	System Model	470 x 600 x 860mm			515 x 673 x 882mm		
Weight	System Model	66kg	67kg	70kg	72kg	73kg	76kg

ErP Efficiency	ErP A (93%)					
EN Regulation (EN13203-1)*	★★★					
NOx Emission Rate	57.2mg/kWh	57.2mg/kWh	63.2mg/kWh	57.2mg/kWh	62.5mg/kWh	63.2mg/kWh

Technical data

		Internal Model			External Model		
		21	28	36	21	28	36
		RS / LS / LC	RS / LS / LC	RS / LS / LC	RSX / LSX / LCX	RSX / LSX / LCX	RSX / LSX / LCX
Heat Output	80/60°C	16/21kW	21/28kW	29/36kW	16/21kW	21/28kW	29/36kW
	50/30°C	23.0kW	30.3kW	39.0kW	23.0kW	30.3kW	39.0kW
Flue	Flue Size	Coaxial Plastic Ø 60/100					
	Max Horizontal Length	20m					
	Max Vertical Length	21m					

Dimensions	Regular Model	470 x 600 x 860mm			515 x 673 x 882mm		
Weight	Regular Mmodel	58kg	59kg	62kg	64kg	65kg	68kg

ErP Efficiency	ErP A (93%)					
EN Regulation (EN13203-1)*	★★★					
NOx Emission Rate	57.2mg/kWh	57.2mg/kWh	63.2mg/kWh	57.2mg/kWh	62.5mg/kWh	63.2mg/kWh

Controls

Intuitive control

Designed with end-users and installers in mind, Navien's control panel is fitted on both internal and external models. Its easy to use display allows full control of the boiler's parameters and eliminates the need for an additional thermostat.



Text Driven

Display shows text to indicate any boiler issues, making them easier and quicker to resolve.

Two Channel Program

Separate programming options for heating and water temperatures.

Zone Control

Allows user to set up three areas of the home as 'zones' and control each one independently.

Fuel Consumption

Shows the amount of energy used and cost at a glance.

3-zone ready

For unrivalled energy efficiency and running costs, the NCB range can be connected to Navien's Smart Plus Control Pack to deliver an A+ energy rating. With simple control of up to 3 zones, it delivers the very latest in home comfort.

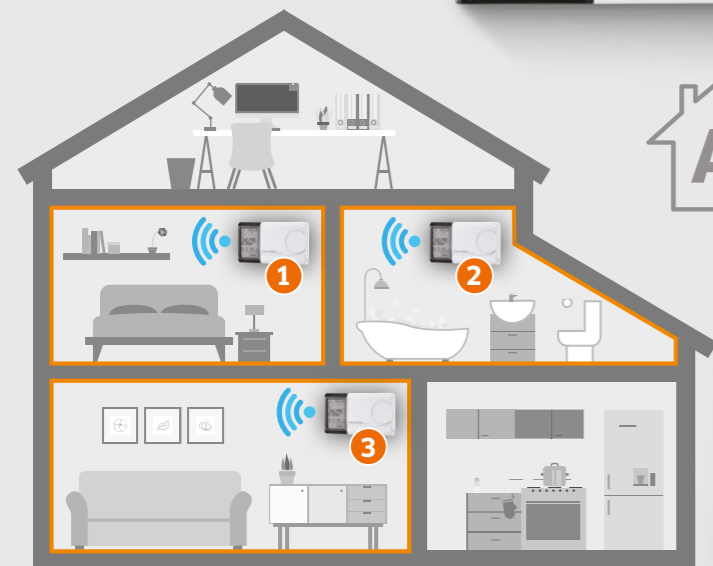

Flues

Flue options

The Navien boiler range can be fitted with our 60/100 plastic flue system, and installed horizontally or vertically. Our flues can also extend up to 21 metres in vertical or 20 metres horizontal (maximum length without bends).

- Significant cost saving compared to aluminium flues
- Easier to cut, saving time on site
- Widely available through plumbers' merchants

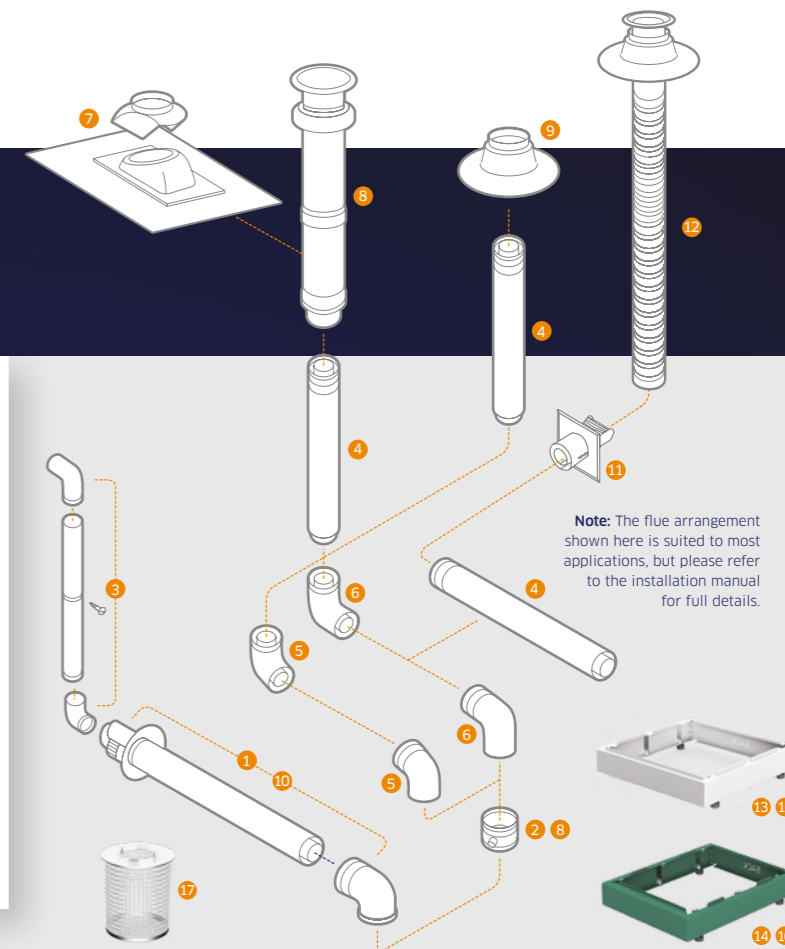

Note: The flue arrangement shown here is suited to most applications, but please refer to the installation manual for full details.

Flue accessories

No.	Product description	Product code	Length / Height	Width	Depth
1	Standard flue horizontal kit	GXXX002208	1000	100	100
2	Vertical flue adaptor	GXXX002220	100	100	100
3	Plume management kit 60mm	GXXX002199	1200	60	60
-	Plume Management 1000mm Flue Extension with wall bracket	GXXX002210	1000	60	60
-	Plume Management Bend 87°	GXXX002054	170	60	60
-	Plume Management Bends 45° 2 in a box	GXXX002055	150	60	60
-	Plume Management Wall Bracket	GXXX002202			
4	500mm flue extension	GXXX002195	500	100	100
4	1000mm flue extension	GXXX002196	1000	100	100
5	45° bend	GXXX002198	150	100	100
6	90° bend	GXXX002197	170	100	100
7	Weather Slate pitched roof	GXXX001878	220	500	500
8	Roof terminal kit with adaptor	GXXX002219	1350	100	1000
9	Weather slate flat roof	GXXX001879	150	115/350	
10	Telescopic flue horizontal kit	GXXX002204	300-460	100	100
11	Ceiling plate flex 60mm	GXXX002005	-	115/350	
12	Flexible flue liner 60mm	GXXX002006	12500	100	100
-	Flue wall bracket	GXXX002203	-	100	100
13	LCB Plinth - Regular and System Boiler - Internal	30023925A	140	470	600
14	LCB Plinth - Regular and System Boiler - External	30023926A	140	470	600
15	LCB Plinth - Combi Boiler - Internal	30023927A	140	600	600
16	LCB Plinth - Combi Boiler - External	30023928A	140	600	600
17	Flue Guard - LCB External Boiler	30028256A	255	230	230

Measurements in MM

4 options to install flue

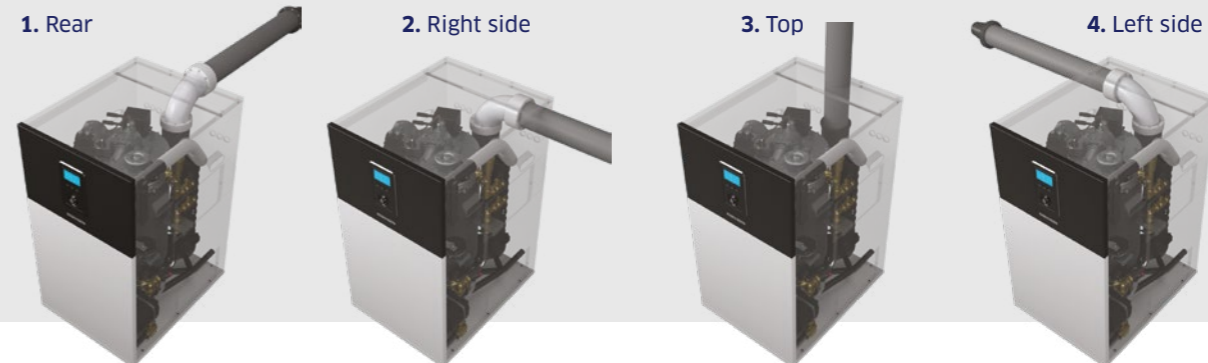

Service

What if the boiler breaks down?

- 24hr / 365d manned customer help line
- Attending to customer issues within two working days
- National service engineer coverage

To contact our service team, call:

0344 332 23 23

email us at:

service@navienuk.com



Training

Free training options

- Designed for installing, servicing and maintaining Navien products
- Training carried out by qualified & experienced Navien technical engineers
- Practical, hands-on training workshops
- Choice of training centres across the UK for you to attend
- **Free** of charge, no cost to you or your colleagues to attend (limited time only)

To contact our training team, call:

0344 332 23 23

email us at:

training@navienuk.com



Support

Navien customer support

- Sales support from a qualified member of staff who can advise on installation and maintenance requirements
- National coverage of Technical Engineers who are a phone call away to answer any of your questions
- Navien Installer App for registering and tracking your installations. The App also details product videos, promotions and much more
- Stock available from a number of national and independent plumbers' merchants

To contact our support team, call:

0344 332 23 23

email us at:

info@navienuk.com



How do I know Navien will be here in the future?

In 2012, Navien became the 4th largest wall-hung gas boiler manufacturer in the world and reached full production capacity. As a result, we built a new factory in 2013 which could produce 2m boilers (the biggest in the world), allowing us to develop into the UK and European markets.

Navien's NEW loyalty scheme

NAVIEN CHOICE



Installers can now receive great rewards on every gas and oil boiler registered through the Navien Installer App. From grabbing a snack on the go, through to the latest tech and gadgets, our points always give you the best prizes...

Bank them or redeem them, it's your choice!



www.navienchoice.com

Terms and conditions apply. UK Mainland Only.

*When purchased as part of either a 'Smart Package' or an 'ErP A+ package'.